

PART NUMBER	REV	FIRST USED	5
1-1385346-1	E		-
1-1385346-2	E		-
1-1385346-3	E		-

MISC CRIMP DATA	
DEUTSCH TERMINAL DEUTSCH SPEC	
WIRE CRIMP SIZE TYPE .140 [3.56mm] F	
WIRE STRIP LENGTH .225-.275	
FEED .651	SET UP GAGE 458637-1
LAYOUT L2537	APPL INSTR 408-8040

TERMINAL APPLICATION CHART

TERMINAL DEUTSCH AMP EQUIV	TERMINAL INSUL RANGE	APPLICATOR PART NUMBER	TOOLING INSUL RANGE	ANVIL	INSUL CRIMPER	INSUL CRIMP WIDTH	WIRE CRIMP WIDTH	WIRE SIZE	CRIMP HEIGHT ±.002 [±0.05]	REF * SETTING
1060-12-02**	286988	1-1385346-1	.185-.204	1-1424534-5	6-904741-2	.190 O	.140 F	6mm ²	.107 [2.72mm]	A6
1062-12-02**	286989	1-1385346-2	.155-.190	1-1424534-9	6-904741-3	.180 O		10 OR 5mm ²	.099 [2.51mm]	B6
		1-1385346-3	.125-.160	1-1424534-6	6-904741-4	.140 O		4mm ²	.085 [2.16mm]	D6

- 1 RECOMMENDED SPARE PARTS.
- 2 GREASE LIGHTLY.
- 3 GUARD MUST BE IN PLACE WHEN OPERATING APPLICATOR IN A BENCH MACHINE.
- 4 LUBRICATE DAILY USING NO. 20 MACHINE OIL.
- 5 APPLICATOR SET UP FOR 40 mm BENCH TERMINATOR FROM THE FACTORY. THIS APPLICATOR MUST BE RECONFIGURED TO RUN IN A DIFFERENT TERMINATOR. PLEASE REFER TO THE CAM CONFIGURATION AND APPLICATOR INSTRUCTION SHEET FOR PROPER FEED ADJUSTMENT.

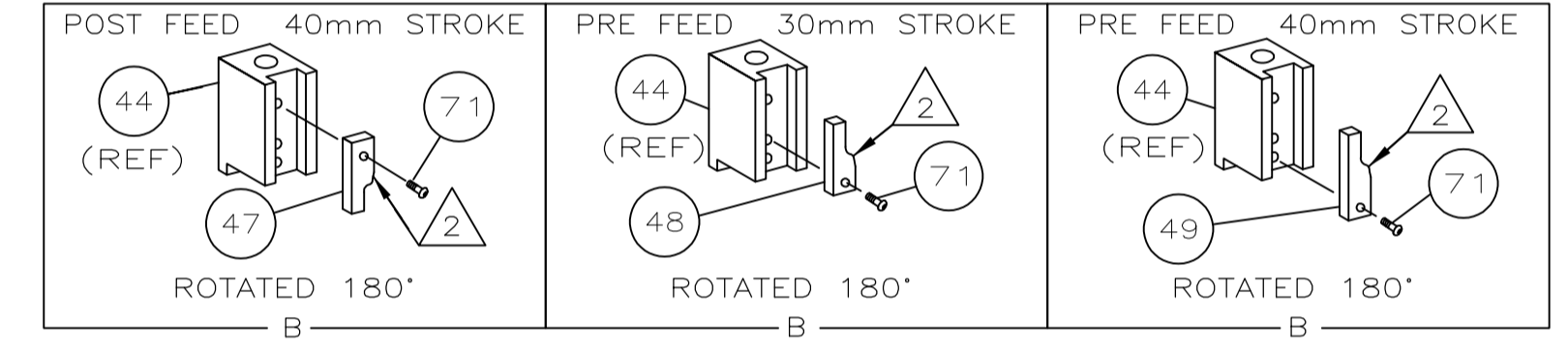

CAM CONFIGURATION

- 6 ** IN TERMINAL NUMBER REFERS TO THE PLATING. CONSULT THE DEUTSCH COMPANY FOR PLATING OPTIONS.
- 7 SHIM MAY NEED TO CHANGE TO OBTAIN ALL CRIMP HEIGHTS FOR ALL TERMINALS.

* WARNING:

ON INSTALLATION, SET WIRE DISC TO LARGEST WIRE SIZE SETTING. USE OF SETTINGS BELOW MIN REQ'D CRIMP HEIGHT SETTING WILL CAUSE DAMAGE TO CRIMP TOOLING.

QTY REQD PER ASSY	PART NO	DESCRIPTION	ITEM NO
	1-1424534-6	ANVIL	108
	6-904741-4	CRIMPER, INSULATION	107
	1-1424534-9	ANVIL	103
	6-904741-3	CRIMPER, INSULATION	102
	4-21028-0	PIN,SLT SPR(Ø.093x.75)ST GDE PL	101

QTY REQD PER ASSY	PART NO	DESCRIPTION	ITEM NO
	21024-5	WASHER, LOCK(#10)ADJ BLOCK	97
	21024-2	WASHER,LOCK(#4)FRONT STP GUIDE	94
	21024-4	WASHER,LOCK(#8)STRIPPER	91
	21018-5	NUT,HEX(NO.6)HOLDDOWN	88
	22353-8	SCR,SHLD(Ø.187X.25)DRAG LEVER	85
	21009-2	SCR,SKT SET(1/4-20x.25 LW)RAM	83
	21017-2	SCR,DRIVE(#2x.19)ID PLATE	82
	461264-5	PLATE, IDENTIFICATION	80
	5-21006-6	SCR,SET(10-32x.75)DRAG	79
	22733-8	SCR,BHC(8-32x.38 LW)ANVIL	78
	2-21002-2	SCR,BHC(8-32x.50)TERM H DWN	74
	1424350-1	HOLDER, PIN, WIRED	72
	1-21002-7	SCR,BHC(6-32x.38)CAM	71
	23147-7	SPRING, DEPRESSOR	70
	2-21000-8	SCR,SHC(8-32x.62)DEP-HOLD	67
	2-22603-0	SCR,HEX HD(8-32x.31)FEED FINGER	66
	1-21000-3	SCR,SHC(4-40x.25)F ST GUIDE	65
	2-21000-7	SCR,SHC(8-32x.50)STRIPPER	64
	3-21000-4	SCR,SHC(10-32x.38)SG ADJ BL	61
	REF REF REF	455749-1 GUARD, WINDOW	59
	REF REF REF	679532-1 INSERT, GUARD	58
	1490524-2	SPACER, DEPRESSOR	56
	1490525-1	DEPRESSOR, WIRE	55
	811242-2	BUMPER, HOLD DOWN	51

QTY REQD PER ASSY	PART NO	DESCRIPTION	ITEM NO
	690753-1	SPACER, TONKER	50
	690602-6	CAM, PRE-FEED 1 5/8 ST	49
	690602-5	CAM, PRE-FEED 1 1/8 ST	48
	690501-4	CAM, POST-FEED 1 5/8 ST	47
	459456-1	APPLICATOR, BASIC (SUBASSY)	46
	690191-1	PLUG, NYLON	45
	455673-1	RAM	44
	690125-1	LAMINATED WASHER	43
	7-21002-9	BOLT, CRIMPER(5/16x1.00)	41
	458537-2	PAWL, FEED	40
	469367-9	SPACER, FINE ADJUST	38
	879103-3	FINE ADJUST HEAD SUBASSY	37
	690786-6	SUPPORT, TERMINAL	34
	690432-3	SCREW, ADJUSTMENT	32
	458144-1	PLATE, STRIP GUIDE	29
	455888-6	SPACER, FRONT SHEAR DEP	28
	1-22284-0	SPRING, DRAG	27
	240793-1	LEVER, DRAG RELEASE	26
	240792-1	DRAG, TERMINAL	25
	1-90765-2	GUIDE, STRIP (REAR)	24
	690438-1	GUIDE, STRIP (FRONT)	23
	2-1338987-9	STRIPPER	19
	318563-1	GUARD, CHIP, FRONT	16
	4-22280-8	SPRING, SHEAR	12
	690461-2	STOP, SHEAR	11
	1-690459-3	HOLDER, SHEAR (FRONT)	10
	2-454276-6	SHEAR, FLOAT (FRONT)	9
	1-1424534-5	ANVIL	8
	1-240641-2	SPACER, DEPRESSOR (REAR)	7
	1-455889-8	DEPRESSOR, SHEAR (FRONT)	5
	238011-2	SPACER, BLOCK CRIMPER	4
	6-904741-2	CRIMPER, INSULATION	3
	8-568176-1	CRIMPER, WIRE	1

LOC A
DIST 66

E	ECR-10-017998	8-2010	MY	GB
P	LTR	REVISION RECORD	DATE	DWN

DIMENSIONS: INCHES		TOLERANCES UNLESS OTHERWISE SPECIFIED:	
0 PLC	± .005	1 PLC	± .002
1 PLC	± .002	2 PLC	± .001
2 PLC	± .001	3 PLC	± .0005
3 PLC	± .0005	4 PLC	± .0002

DWN	16JAN02	MATERIAL	-	HEAT TREAT	-
CHK	C.ERISMAN				
APVD	16JAN02				
T.BENCHOFF		Tyco Electronics Corporation Harrisburg, PA 17105-3608			
SIDE FEED HDM APPLICATOR					
SCALE	A1	DRAWING NO	1385346	SHEET	1 of 2
REV	E				

THIS DRAWING IS A CONTROLLED DOCUMENT. 1385346

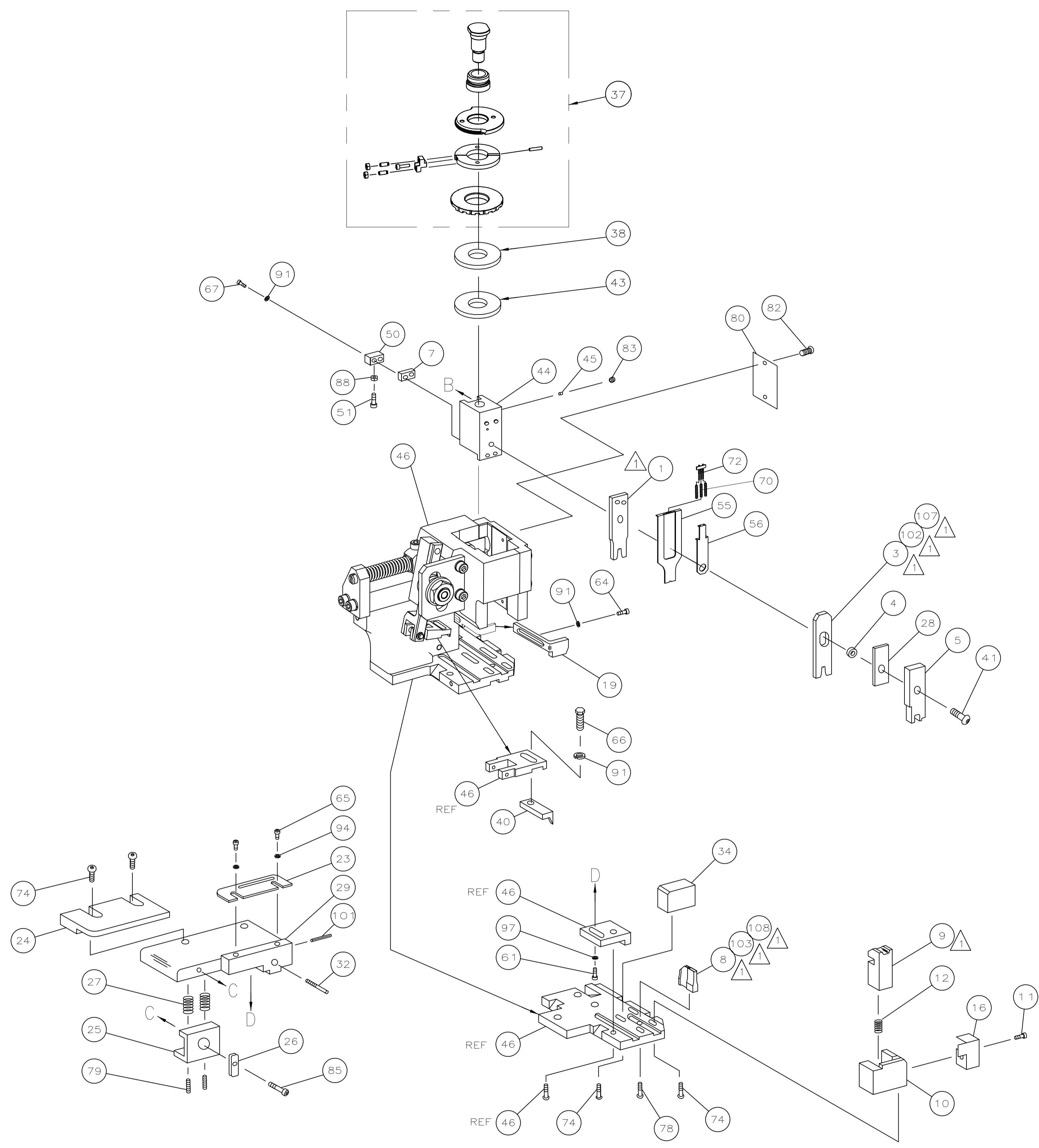

THIS INFORMATION IS CONFIDENTIAL AND PROPRIETARY TO TYCO ELECTRONICS CORPORATION AND ITS WORLDWIDE SUBSIDIARIES AND AFFILIATES. IT MAY NOT BE DISCLOSED TO ANY OTHER PARTY WITHOUT THE EXPRESS WRITTEN AUTHORIZATION FROM TYCO ELECTRONICS CORPORATION, HARRISBURG, PENNSYLVANIA, USA.

LOC A
DIST 66

3308-8 (1/08)

P	LTR	REVISION RECORD	DATE	DWN	APVD
-	-	SEE SHEET 1	-	-	-

DIMENSIONS:		TOLERANCES UNLESS OTHERWISE SPECIFIED:	
INCHES	0 PLC	± .005	
	1 PLC	± .002	
	2 PLC	± .001	
	3 PLC	± .0005	
	4 PLC	± .0002	
ANGLES:		SURFACE TEXTURE: ✓	

DWN	16JAN02	MATERIAL	HEAT TREAT
C.ERISMAN	-	-	-
CHK	-	-	-
APVD	16JAN02	Tyco Electronics Corporation Harrisburg, PA 17105-3608	
NAME: T.BENCHOFF			
SCALE: - SIZE: A1 DRAWING NO: 1385346 SHEET 2 of 2 REV E			

CUSTOMER ACCESSIBLE PRODUCTION DRAWING