



### PRODUCT OVERVIEW

D1U54T-800W-12-HBxC is a series of 800W highly efficient, 80 PLUS® certified Titanium front end power supplies that provide a 12Vdc (main), and a standby output. Active current sharing, multifunctional status LED, hardware logic signals and PMBus™ digital communications are standard features and the low profile 1U, 26.7W/cubic inch package make this series ideal for delivering reliable, efficient power to servers, workstations, storage systems and other 12V distributed power architectures.

### ORDERING GUIDE

Part Number	Total Output Power (nominal input)		Main Output	Standby Output	Airflow Direction	AC Connector Type
	100Vac	110-240Vac				
D1U54T-W-800-12-HB3C	730W	810W	12Vdc	12Vdc	Front to Back Back to Front	1 IEC60320-C14
D1U54T-W-800-12-HB4C						

<sup>1</sup> Contact Murata for availability of IEC60320-C16 AC inlet models

### FEATURES

- Up to 810W continuous output power
- 96% efficiency at 50% Load, 80 Plus® certified Titanium
- 12V main output
- 12V Standby Output
- 1U height: 2.15" x 9.00" x 1.57"
- > 26.7 Watts per cubic inch density
- N+1 redundant, Hot Swap Capable
- Active (digital) current sharing on 12V main output; droop standby output; Integral ORing /isolation provided for both outputs
- Internal cooling fan (variable speed)
- Overvoltage, overcurrent, over temperature Protection
- PMBus™/I<sup>2</sup>C interface with LED status indicators
- RoHS compliant
- Two Year Warranty

### INPUT CHARACTERISTICS

Parameter	Conditions	Min.	Nom.	Max.	Units
Input Source Voltage Operating Range		90	100-240	264	Vac
Input Source Frequency		47	50/60	63	Hz
Turn-on Input Voltage	Ramp up	74		84	
Turn-off Input Voltage	Ramp down	70		80	Vac
Maximum current at Vin = 100Vac	730W; based on AC Connector			9	Arms
Inrush Current	Cold start between 0 to 200msec			25	Apk
Power Factor	At 230Vac, 100% load	0.96			
	At 230Vac, 50% load	0.95			
	At 230Vac, 20% load	0.95			
Efficiency (230Vac) excluding fan load (80 Plus® certified)	10% load	90			
	20% load	94			
	50% load	96			%
	100% load	95			

### OUTPUT VOLTAGE CHARACTERISTICS

Nominal Output Voltage	Parameter	Conditions	Min.	Typ.	Max.	Units
12V	Output Set Point Accuracy	50% load; Tamb = 25°C	11.96	12.00	12.04	Vdc
	Line and Load Regulation	Setpoint; temperature; line and load	-1.0%		+1.0	%
	Ripple Voltage & Noise <sup>2</sup>	20MHz Bandwidth			120	mV p-p
	Output Current Range	HB3C model 110-240Vac; 50°C max. ambient	0		66.5	A
		HB4C <sup>1</sup> model 120-240Vac; 45°C max. ambient	0		66.5	
	Load Capacitance		500		4000	µF
12VSB	Output Set Point Accuracy	50% load; Tamb = 25°C	11.96	12.00	12.04	Vdc
	Line and Load Regulation	Setpoint; temperature; line and load	11.7		12.3	
	Droop Characteristic			150		mV/A
	Ripple Voltage & Noise <sup>2</sup>	20MHz Bandwidth			120	mV p-p
	Output Current		0		1	A

<sup>1</sup> Output power derating @ 100VAC to 730W maximum output power at 45°C max. ambient temperature applies to HB4C (B-F airflow) model.  
<sup>2</sup> Ripple and noise are measured with 0.1 µF of ceramic capacitance and 10 µF of tantalum capacitance on each of the power supply outputs. A short coaxial cable to the measurement 'scope input, is used.



Available now at:  
<https://power.murata.com/en/3d/acd>



For full details go to  
[www.murata-ps.com/rohs](http://www.murata-ps.com/rohs)

### OUTPUT CHARACTERISTICS

Parameter	Conditions	Min.	Typ.	Max.	Units
Startup Time	AC ramp up			3	s
Transient Response	Main 12V, 50% load step, 1A/ $\mu$ s di/dt from, >5% Max. Load			$\pm$ 5	%
	12VSB, 50% load step, 1A/ $\mu$ s di/dt			500	$\mu$ s
Current sharing accuracy (Main 12V output)	>10% load; (* percentage of full load)			$\pm$ 5*	%
Hot Swap Transients				$\pm$ 5	%
Holdup Time	Full AC Input Source Range; 80% load	10			ms
	Full AC Input Source Range; 50% load	16			

### ENVIRONMENTAL CHARACTERISTICS

Parameter	Conditions	Min.	Typ.	Max.	Units
Storage Temperature Range		-40		70	°C
Operating Temperature Range	See output power derating curve below for additional conditions	0		50	
Operating Humidity	Noncondensing	5		92	%
Storage Humidity		5		95	
Altitude (without derating at 40°C)				3000	m
Shock	30G non-operating				
Operational Vibration	Sine sweep; 5-200Hz, 2G; random vibration, 5-500Hz, 1.11G				
MTBF(Target)	Per Telcordia SR-332 M1C1 @40°C		400K		hrs
Safety Approvals (Pending Submission)	CAN/CSA-C22.2 No. 60950-1-07, Amendment 1:2011, Amendment 2:2014 (MOD) ANSI/UL 60950-1-2014 IEC 60950-1:2005, IEC 60950-1:2005/AMD1:2009, IEC 60950-1:2005/AMD2:2013 EN 60950-1:2006+A11:2009+A1:2010+A12:2011+A2:2013				
Input Fuse	Power Supply has internal 16A/250V fast blow fuse on the AC line input				
Weight	1.7 lbs (0.77 kg)				

### PERFORMANCE DATA

D1U54T-W-800-12-HB3C P-Q Airflow (front to back air direction)

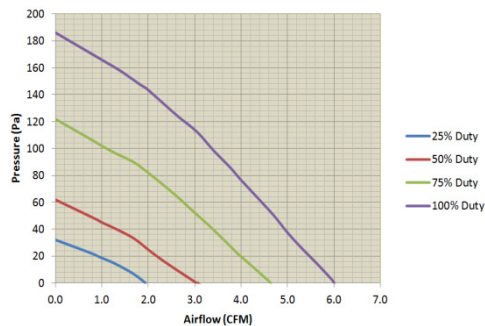

D1U54T-W-800-12-HB4C P-Q Airflow (back to front air direction)

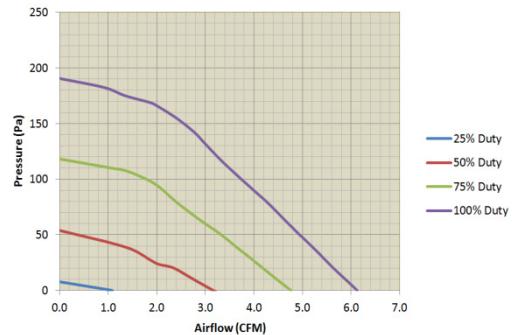

Reference file: M1888 Airflow Test Report (8-31-2018)

Output Power Derating (HB4C, B-F C14 models)

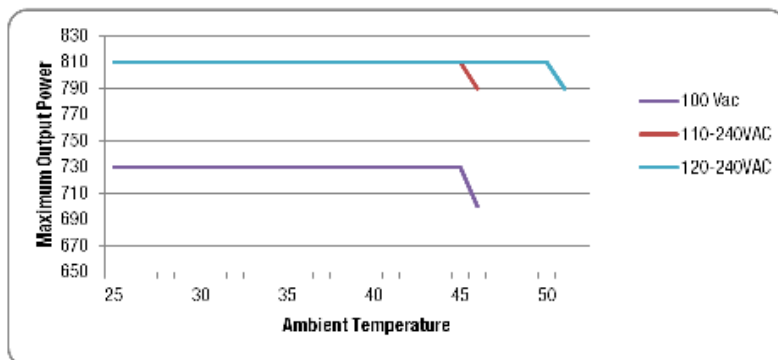

PROTECTION CHARACTERISTICS						
Output	Parameter	Conditions	Min.	Typ.	Max.	Units
	Overtemperature (intake)	Auto restart with 4°C hysteresis for recovery (warning issued at 70°C)		75		°C
12V	Overtoltage	Latching	13.0		14.5	V
	Overcurrent	The output shall shutdown when an overcurrent condition is detected. It will auto restart after 1sec; however if the overcurrent condition is redetected the output will once again shutdown. The output will once again re-start, however if the overcurrent condition persists it will latch of after the fifth unsuccessful attempt. To reset the latch it will be necessary to toggle the PS_ON_L signal (B4) or recycle the incoming AC source.	69		82	A
12VSB	Overtoltage	Latching	13.0		14.5	V
	Overcurrent	The output shall shutdown when an overcurrent is detected. It will auto restart after 2sec; however if the overcurrent is re-detected the output will once again shutdown. This cycle will occur indefinitely while the overcurrent condition persists.	1.1		3	A

ISOLATION CHARACTERISTICS						
Parameter	Conditions	Min.	Typ.	Max.	Units	
Insulation Safety Rating	Input to Output - Reinforced	3000			Vrms	
	Input to Chassis - Basic	1500			Vrms	
	Output to Chassis	500			Vdc	

EMISSIONS AND IMMUNITY		
Characteristic	Standard	Compliance
Input Current Harmonics	IEC/EN 61000-3-2	Complies
Voltage Fluctuation and Flicker	IEC/EN 61000-3-3	Complies
Conducted Emissions	FCC 47 CFR Part 15 CISPR 22/EN55022	Class A with 6dB margin
ESD Immunity	IEC/EN 61000-4-2	Level 4 criteria A
Radiated Field Immunity	IEC/EN 61000-4-3	Level 3 criteria A
Electrical Fast Transients/Burst Immunity	IEC/EN 61000-4-4	Level 3 criteria A
Surge Immunity	IEC/EN 61000-4-5	1) EN61000-4-5, Lev. 3 (Com. Mode: 2kV, 12Ω, Diff. Mode: 1kV, 2Ω), criteria A 2) GR-1089-CORE (NEBS) Level 1 Table 4-30 (Com/Diff. Mode: 2kV, 2Ω)
RF Conducted Immunity	IEC/EN 61000-4-6	Level 3 criteria A
Voltage Dips, Interruptions	IEC/EN 61000-4-11	230Vin, 80% load, Phase 0°, Dip 100% Duration 10ms (A) 230Vin, 50% load, Phase 0°, Dip 100% Duration 20ms (VSB:A,V1:B) 230Vin, 100% load, Phase 0°, Dip 100% Duration > 20ms (VSB,V1:B)

STATUS INDICATORS			
LED NAME	LED MODE	LED STATE/OPERATION	DESCRIPTION
Input	OK	Solid Green	Input voltage operating within normal specified range
Input	OV/UV WARNING	Blinking Green	Input voltage operating in: 1) overvoltage warning, or 2) undervoltage warning range
Input	OFF OR FAULT	Off	Input voltage operating: 1) above overvoltage range, or 2) below undervoltage range, or 3) not present
Output	POWER GOOD	Solid Green	Main output and standby output enabled with no power supply warning or fault detected
Output	STANDBY	Blinking Green	Standby output enabled with no power supply warning or fault detected
Output	WARNING	Blinking Amber	Power supply warning detected as per PMBus™ STATUS_X reporting bytes*
Output	FAULT	Solid Amber	Power supply fault detected as per PMBus™ STATUS_X reporting bytes*

\*LED fault/warning operation follows PMBus™ fault/warning reporting status flags however are not be 'sticky' (LED will revert to normal upon clearance of fault stimulus, however the status register bit flags will remain set).

STATUS AND CONTROL SIGNALS			
Signal Name	I/O	Description	Interface Details
INPUT_OK (AC Source)	Output	The signal output is driven high when input source is available and within acceptable limits. The output is driven low to indicate loss of input power. There is a minimum of 1ms pre-warning time before the signal is driven low prior to the PWR_OK signal going low. The power supply must ensure that this interface signal provides accurate status when AC power is lost.	Pulled up internally via 10K to 3.3Vdc. A logic high >2.0Vdc A logic low <0.8Vdc Driven low by internal CMOS buffer (open drain output).
PW_OK (Output OK)	Output	The signal is asserted, driven high, by the power supply to indicate that all outputs are valid. If any of the outputs fail then this output will be hi-Z or driven low. The output is driven low to indicate that the Main output is outside of lower limit of regulation (11.4Vdc).	Pulled up internally via 10K to 3.3Vdc. A logic high >2.0Vdc A logic low <0.8Vdc Driven low by internal CMOS buffer (open drain output).
SMB_ALERT (FAULT/WARNING)	Output	The signal output is driven low to indicate that the power supply has detected a warning or fault and is intended to alert the system. This output must be driven high when the power is operating correctly (within specified limits). The signal will revert to a high level when the warning/fault stimulus (that caused the alert) is removed. This signal also corresponds to status LED indicator warning or fault LED state.	Pulled up internally via 10K to 3.3Vdc. A logic high >2.0Vdc A logic low <0.8Vdc Driven low by internal CMOS buffer (open drain output).
PRESENT_L (Power Supply Absent)	Output	The signal is used to detect the presence (installed) of a PSU by the host system. The signal is connected to PSU logic SGND within the power module.	Passive connection to +VSB_Return. A logic low <0.8Vdc
PS_ON (Power Supply Enable/Disable)	Input	This signal is pulled up internally to the internal housekeeping supply (within the power supply). The power supply main 12Vdc output will be enabled when this signal is pulled low to +VSB_Return. In the low state the signal input shall not source more than 1mA of current. The 12Vdc output will be disabled when the input is driven higher than 2.4V, or open circuited. Cycling this signal shall clear latched fault conditions.	Pulled up internally via 10K to 3.3Vdc. A logic high >2.0Vdc A logic low <0.8Vdc Input is via CMOS Schmitt trigger buffer.
PS_KILL	Input	This signal is used during hot swap to disable the main output during hot swap extraction. The input is pulled up internally to the internal housekeeping supply (within the power supply). The signal is provided on a short (lagging pin) and should be connected to +VSB_Return.	Pulled up internally via 10K to 3.3Vdc. A logic high >2.0Vdc A logic low <0.8Vdc Input is via CMOS Schmitt trigger buffer.
ADDR (Address Select) Link to:	Input	An analog input that is used to set the address of the internal slave devices (EEPROM and microprocessor) used for digital communications. Connection of a suitable resistor to +VSB_Return, in conjunction with an internal resistor divider chain, will configure the required address. See address selection table below.	DC voltage between the limits of 0 and +3.3Vdc.
SCL (Serial Clock)	Both	A serial clock line compatible with PMBus™ Power Systems Management Protocol Part 1 – General Requirements Rev 1.1. No additional internal capacitance is added that would affect the speed of the bus. The signal is provided with a series isolator device to disconnect the internal power supply bus in the event that the power module is unpowered,	V <sub>L</sub> is 0.8V maximum V <sub>OL</sub> is 0.4V maximum when sinking 3mA V <sub>H</sub> is 2.1V minimum
SDA (Serial Data)	Both	A serial data line compatible with PMBus™ Power Systems Management Protocol Part 1 – General Requirements Rev 1.1. The signal is provided with a series isolator device to disconnect the internal power supply bus in the event that the power module is unpowered,	V <sub>L</sub> is 0.8V maximum V <sub>OL</sub> is 0.4V maximum when sinking 3mA V <sub>H</sub> is 2.1V minimum
V1_SENSE V1SENSE_RTN	Input	Remote sense connections intended to be connected at and sense the voltage at the point of load. The voltage sense will interact with the internal module regulation loop to compensate for voltage drops due to connection resistance between the output connector and the load. If remote sense compensation is not required then the voltage can be configured for local sense by: 1. V1_SENSE directly connected to power blades 6 to 10 (inclusive) 2. V1_SENSE_RTN directly connected to power blades 1 to 5 (inclusive)	Compensation for a up to 0.12Vdc total connection drop (output and return connections).
ISHARE	Bi-Directional Analogue Bus	The current sharing signal is connected between sharing units (forming an ISHARE bus). It is an input and/or an output (bi-directional analog bus) as the voltage on the line controls the current share between sharing units. A power supply will respond to a change in this voltage but a power supply can also change the voltage depending on the load drawn from it. On a single unit the voltage on the pin (and the common ISHARE bus would read approximately 8VDC at 100% load (module capability). For two identical units sharing the same 100% load this would read approximately 4VDC for perfect current sharing (i.e. 50% module load capability per unit).	Analogue voltage: Approximately + 8V maximum; 10K to +12V_RTN

**ADDRESS SELECTION**

ADDR pin (A3) resistor to GND (K-ohm)*	Power Supply Main Controller (Serial Communications Slave Address)	Power Supply External EEPROM (Serial Communications Slave Address)
0.82	0xB0	0xA0
2.7	0xB2	0xA2
5.6	0xB4	0xA4
8.2	0xB6	0xA6
15	0xB8	0xA8
27	0xBA	0xAA
56	0xBC	0xAC
180	0xBE	0xAE

\* The resistor shall be +/-5% tolerance

**TIMING SPECIFICATIONS**

Turn-On Delay & Output Rise Time:

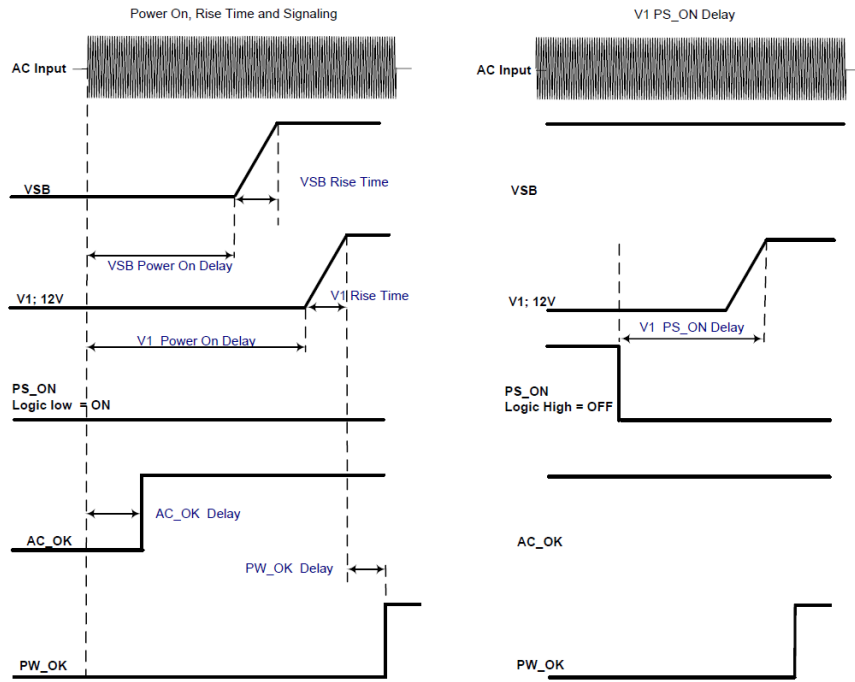

Time	Min	Max
Vsb Rise time	50ms	200ms
V1 Rise time	1ms	120ms
Vsb Power-on-delay		2700ms
V1 Power-on-delay		3000ms
V1 PS_ON delay	100ms	150ms
V1 PWOK delay	100ms	300ms
ACOK detect	400ms	600ms

The turn-on delay after application of AC input within the operating range shall as defined in the following tables.  
 The output rise times shall be measured from 10% of the nominal output to the lower limit of the regulation band as defined in the following tables.

Turn-Off (Shutdown by PS\_ON)

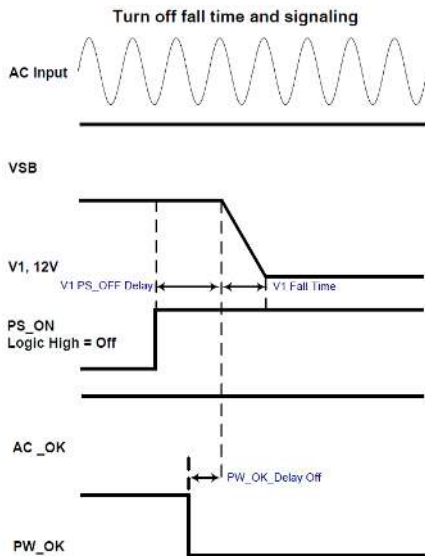

Turn-Off Timing	Min	Max	Notes
V1 Fall time	-	-	Must be monotonic
V1 PS_OFF delay	0ms	5ms	
PW_OK delay off	0.5ms		

this characteristic is applicable for the main 12Vdc output shutdown from PS\_ON pulled high.

**TIMING SPECIFICATIONS** continued

Power Removal Holdup

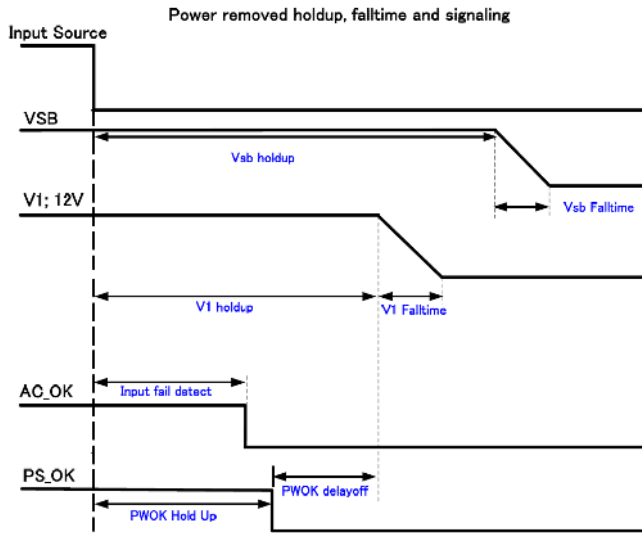

Power Removal Timing	Min	Max	Notes
Vsb holdup	40ms	-	
V1 holdup	10ms	-	80% load
AC fail detect	5.0ms	8.0ms	
PWOK delay off	0.5ms		

**OUTPUT CONNECTOR SPECIFICATION**

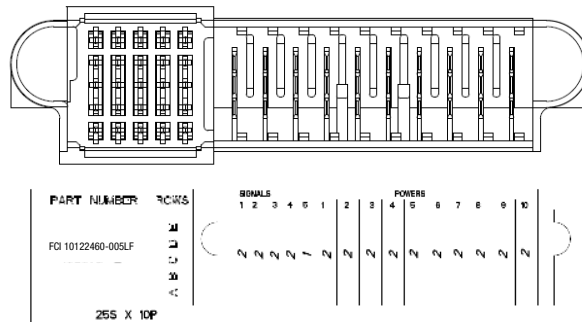

Note: "2" refers to the longest signal pin/power blade & "1" is the "shortest" signal pin such that the "shortest" is the "last to make, first to break" in the mating sequence.

**OUTPUT CONNECTOR PIN ASSIGNMENTS**

FCI 10122460-005LF (Power Supply)

FCI 10108888-R10253SLF (Mating connector)

TE Connectivity PN 2-1926739-5 (Mating Connector)

Pin	Signal Name	Comments	Pin	Signal Name	Comments
6,7,8,9,10	V1 (+12VOUT)	+12V Main Output	C3	SDA	I <sup>2</sup> C Serial Data Line
1, 2, 3, 4, 5	+12V RTN/PGND	+12V Main Output Return	D3	V1_SENSE_R	-VE Remote Sense Return
A1	+VSB	Standby Output	E3	V1_SENSE	+VE Remote Sense
B1	+VSB	Standby Output	A4	SCL	I <sup>2</sup> C Serial Clock Line
C1	+VSB	Standby Output	B4	PS_ON_L	Remote On/Off (Enable/Disable)
D1	+VSB	Standby Output	C4	SMB_ALERT	Alert signal to host system
E1	+VSB	Standby Output	D4	Unused	No End User Connection
A2	+VSB_Return	Standby Output Return	E4	AC_OK	AC Input Source Present & "OK"
B2	+VSB_Return	Standby Output Return	A5	PS_KILL	Power Supply "kill"; short pin
C2	Unused	No End User Connection	B5	ISHARE	Active Current Share Bus
D2	Unused	No End User Connection	C5	PW_OK	Power "OK"; short pin
E2	Unused	No End User Connection	D5	Unused	No End User Connection
A3	ADDR	I <sup>2</sup> C Address Protocol Selection; (Select address by appropriate pull down resistor – See table below)	E5	PRESENT_L	Power Module Present; short pin
B3	Unused	No End User Connection			

WIRING DIAGRAM FOR OUTPUT

Dotted lines show optional remote sense connections.  
Optional remote sense lines can be attached to a load that is a distance away from the power supply to improve regulation at the load.

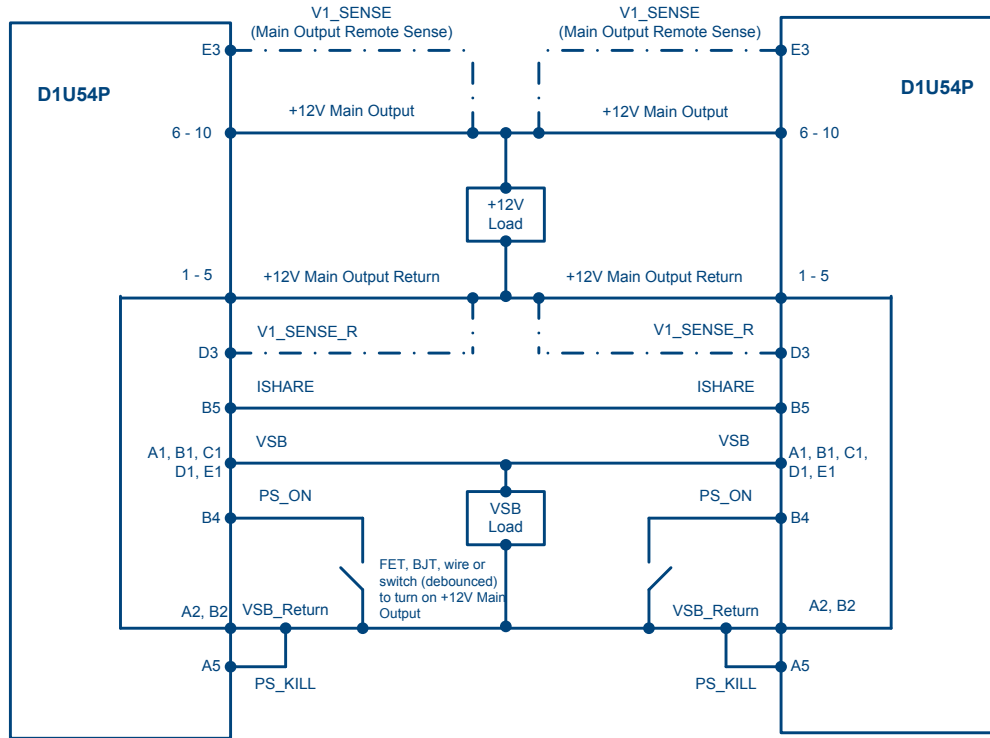

CURRENT SHARE NOTES

1. Main Output: Current sharing is achieved using the active current share method details.)
2. Current sharing can be achieved with or without the remote (V\_SENSE) connected to the common load.
3. +VSB Outputs can be tied together for redundancy but total combined output power must not exceed the rated standby power. The +VSB output has an internal ORING MOSFET for additional redundancy/internal short protection.
4. The current sharing pin B5 is connected between sharing units (forming an ISHARE bus). It is an input and/or an output (bi-directional analog bus) as the voltage on the line controls the current share between sharing units. A power supply will respond to a change in this voltage but a power supply can also change the voltage depending on the load drawn from it. On a single unit the voltage on the pin (and the common ISHARE bus would read approximately 8VDC at 100% load. For two units sharing the same load this would read approximately 4VDC for perfect current sharing (i.e. 50% load per unit).
5. The load for both the main 12V and the VSB rails at initial startup shall not be allowed to exceed the capability of a single unit. The load can be increased after a delay of 3sec (minimum), to allow all sharing units to achieve steady state regulation.



**MECHANICAL OUTLINE**

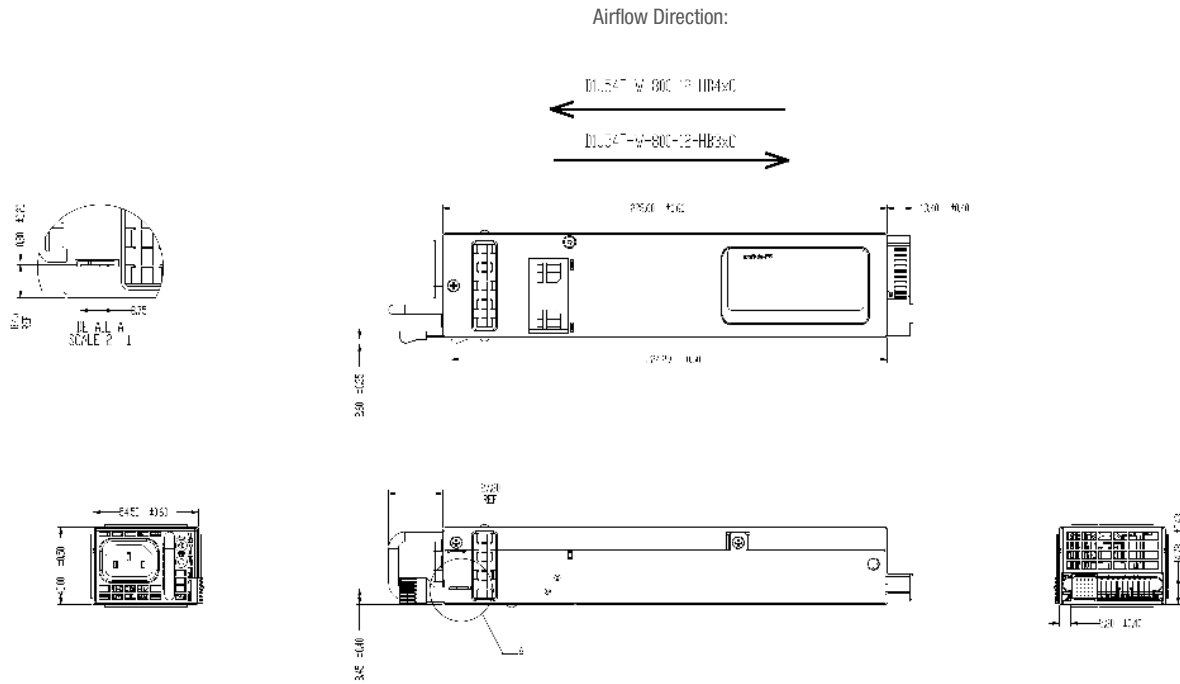

**Notes:**  
 The features of actual product may vary in appearance from this graphical representation and shows the details required for system design. Internal but visible part features such as screw head patterns, plastic parts, fan and connector, handle, latch may vary in actual appearance. It is recommended a golden sample be retained for QA incoming inspection purposes.

AC input connector:  
 HBxC models: IEC 320-C14 (shown)  
 Drawing NTS

**OPTIONAL ACCESSORIES**

Description	Part Number
12V D1U54P Output Connector Card	D1U54P-12-CONC

**APPLICATION NOTES**

Document Number	Description	Link
ACAN-64	D1U54P Output Connector Card	<a href="http://power.murata.com/datasheet?/data/apnotes/acan-64.pdf">http://power.murata.com/datasheet?/data/apnotes/acan-64.pdf</a>
ACAN-88	PMBus™ Communications Protocol	<a href="http://power.murata.com/datasheet?/data/apnotes/acan-88.pdf">http://power.murata.com/datasheet?/data/apnotes/acan-88.pdf</a>

Murata Power Solutions, Inc.  
 129 Flanders Rd. Westborough,  
 Ma 01581, USA.  
 ISO 9001 and 14001 REGISTERED



**This product is subject to the following operating requirements and the Life and Safety Critical Application Sales Policy. Refer to: <http://www.murata-ps.com/requirements/>**

Murata Power Solutions, Inc. ("Murata") makes no representation that the use of its products in the circuits described herein, or the use of other technical information contained herein, will not infringe upon existing or future patent rights. The descriptions contained herein do not imply the granting of licenses to make, use, or sell equipment constructed in accordance therewith. Buyer represents and agrees that it has all the necessary expertise to create and implement safeguards that anticipate dangerous consequences of failures, monitor failures and their consequences, lessen the likelihood of failures that might cause harm, and take appropriate remedial actions. Buyer will fully indemnify Murata, its affiliated companies, and its representatives against any damages arising out of the use of any Murata products in safety-critical applications. Specifications are subject to change without notice.

© 2018 Murata Power Solutions, Inc.