

REV.		DESCRIPTION	RELEASED DATE	APPROVED
E	22814	ITEM 3 WAS -001	2-18-93	WS
F	23843	ADDED ITEM 13	8/9/93	WS
K	06-00057	CHANGED ITEM 7 VIEW TO PHILLIPS	05/12/19	CB
L	11-024834	ITEM 6 WAS -054	11/12/01	CB

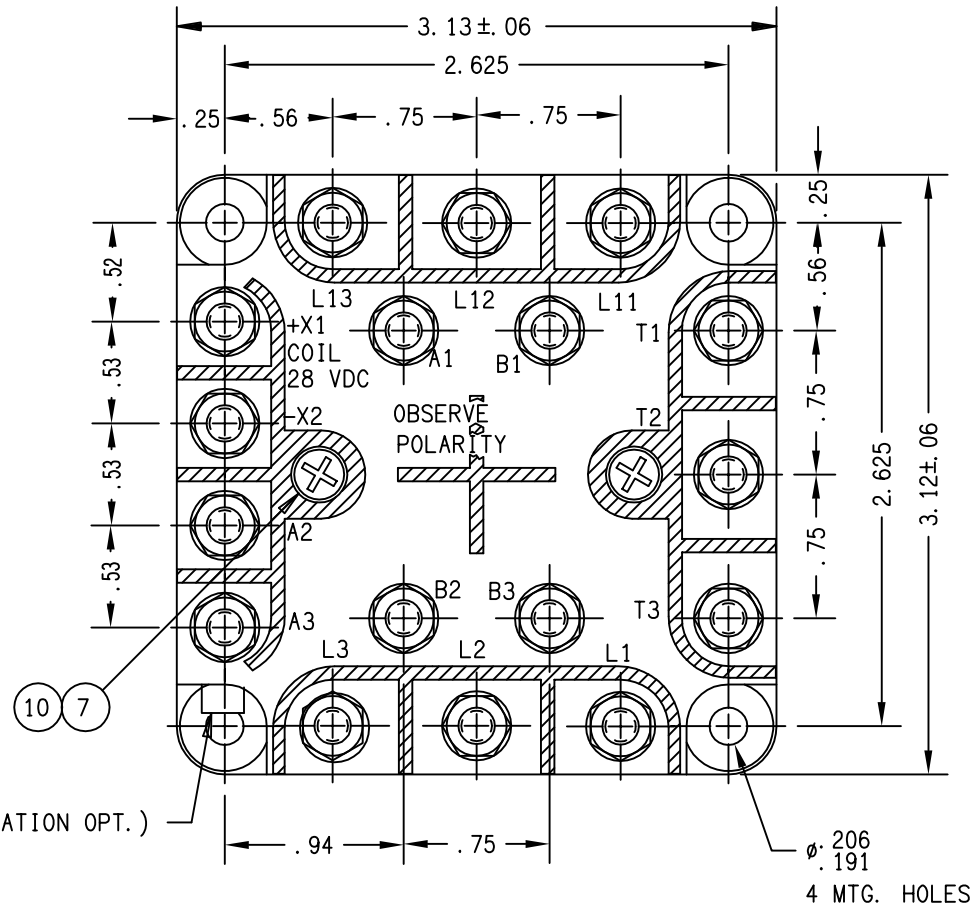

NOMINAL OPERATING VOLTAGE
 COIL
 CONTACTS
 PICKUP VOLTAGE
 DROPOUT VOLTAGE
 CONTACT ARRANGEMENT
 CONTACT RATING
 RESISTIVE
 INDUCTIVE
 LAMP
 MOTOR
 CAPACITIVE
 AUX. CONTACT RATING AT 28 VDC & 115 VAC. 400 HZ
 RESISTIVE
 INDUCTIVE
 MOTOR
 MAIN & AUX. CONTACT OPERATING TIMES
 CLOSING
 OPENING
 TRANSFER
 COIL CURRENT AT 29 V (EST) MAX & 25° C
 INRUSH
 MIN. OPERATING CYCLES ELECTRICAL
 MAX AMBIENT TEMPERATURE
 MAX WEIGHT

28 VDC
 115/200 VAC 400 HZ
 18 V MAX AT 85° C
 7.0 TO 1.5 VDC
 TPDT NC
 60 AMP AC
 35 AMP AC
 10 AMP AC
 15 AMP AC
 60 AMP AC
 5 AMP
 3 AMP
 3 AMP
 50 MS MAX AT 18 VDC
 35 MS MAX AT 28 VDC
 10 MS AT 30 VDC
 .5 AMP MAX
 5 AMP MAX
 50,000
 -40° C TO +71° C
 1 LB 8 OZ

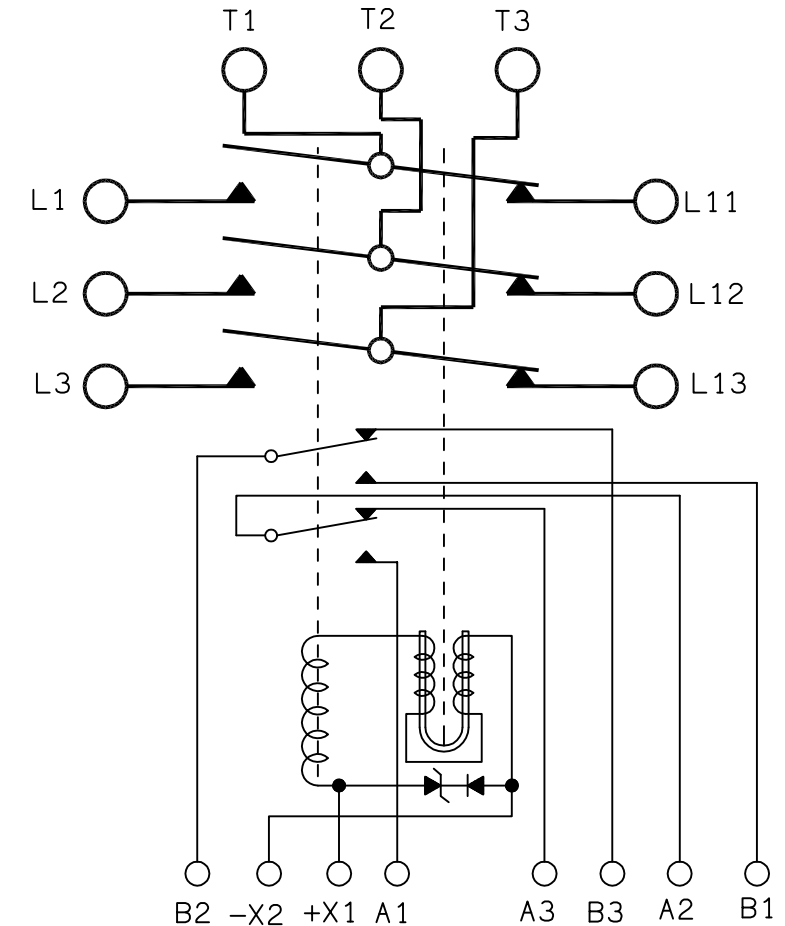

VENT (LOCATION OPT.)

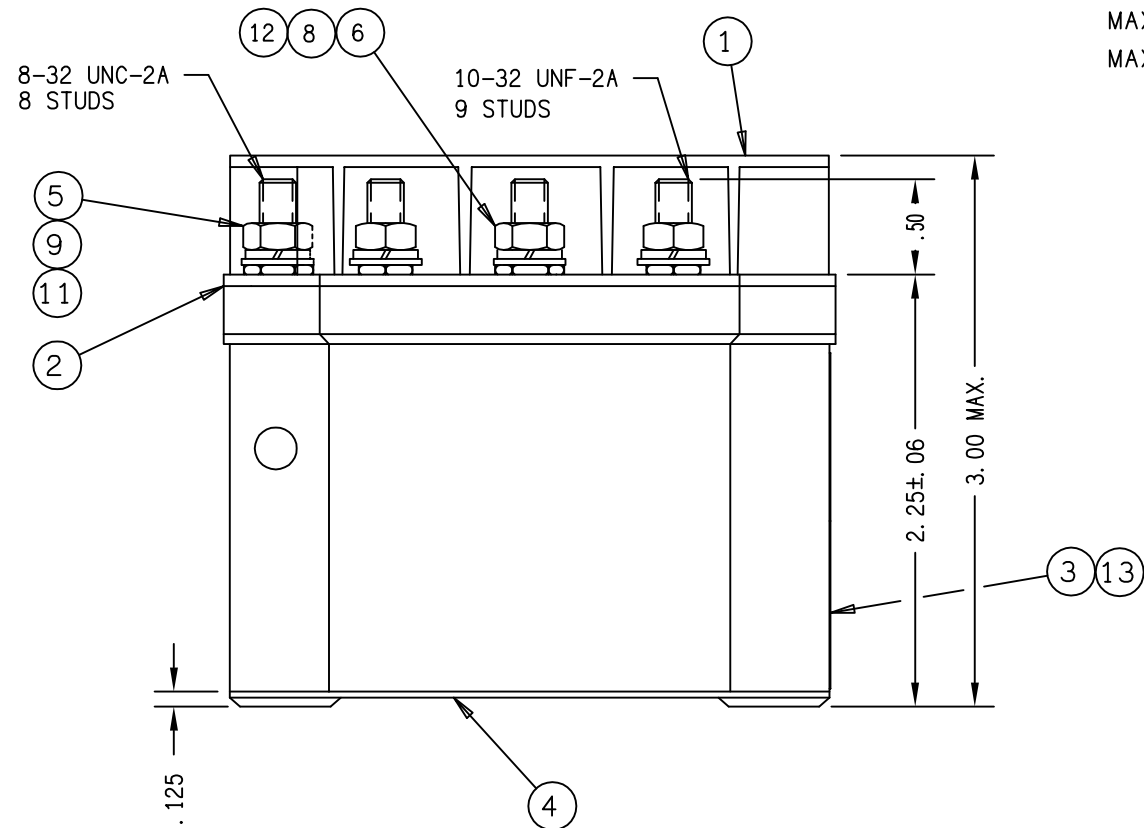

NOTES:

1. TERMINAL COVER TO BE STAMPED "DANGER HIGH VOLTAGE".
2. COIL TRANSIENT VOLTAGE LIMITED TO ±42 VOLTS REFERENCED TO ZERO VOLTS.

FIND NO	QTY REQD	PART OR IDENTIFYING NO	NOMENCLATURE OR DESCRIPTION	FSCM NO	DRAWING OR SPECIFICATION	MATERIAL OR NOTE
13	1	39529-001	OVERLAY			
12	9	51810-054	WASHER - LOCK NO. 10 SPLIT		MS35338-100	BRONZE
11	8	51808-064	WASHER - LOCK NO. 8 X .307 MAX. X .047 SPLIT		MS35338-99	BRONZE
10	2	51806-034	WASHER - LOCK NO. 6 INT.		MS35333-68	BRONZE
9	8	51712-104	WASHER - 3/8 X 11/64 X .032		AN961-8	BRASS
8	9	51702-844	WASHER - 3/8 X 13/64 X .032		AN961-10	BRASS
7	2	51206-644	SCREW - 6-32 X 3/4 RD. HD.		MS35214-29	BRASS
6	9	50410-174	NUT - 10-32 X 5/16 X 9/64 HEX.			BRASS
5	8	50408-034	NUT - 8-32 X 5/16 X 3/32 HEX.			BRASS
4	1	21432-040	CONTACTOR ASSEMBLY - PRIMARY			
3	1	16043-035	PLATE - NAME			
2	1	14898-001	PLATE - BASE COVER			
1	1	12531-003	SHIELD - TERMINAL			

UNLESS OTHERWISE SPECIFIED DIMENSIONS ARE IN INCHES TOLERANCES ON

2 PL DEC.	3 PL DEC.	ANGLES
±.03	±.010	± 1°

DR BY LCB 93/09/02
 CHK BY WS 93/09/17
 ENGR KK 93/09/23
 MFG JF 93/09/22

REF: SIKORSKY 70550-22901-101

SIZE C CODE IDENT 74063

SCALE NONE SHEET

TE
 Hartman Division 175 N. DIAMOND STREET MANSFIELD, OHIO 44902

CONTACTOR - T. P. D. T. N. C. 093

DWG NO. B-138XEH

REF TE P/N 1616028-3