

1

2

3

4

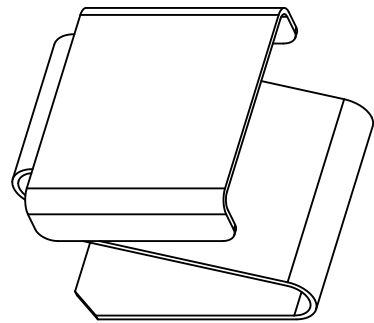

3D VIEW.

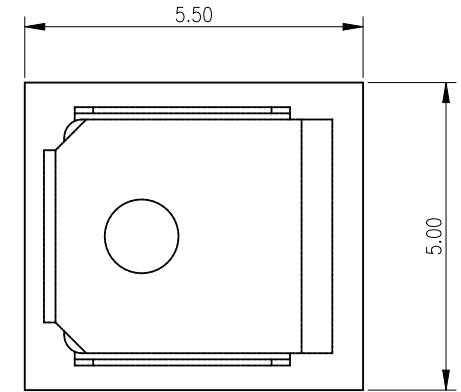
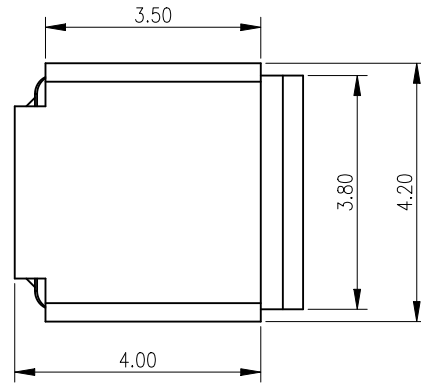

P.C.B LAYOUT:TOL±0.10

REV.	ECR/ECN No.	DESCRIPTION	DRAWN/DATE	CHECKED/DATE	APPROVED/DATE
A		NEW RELEASE	Kun Chen 2015-11-18	Bing Ye 2015-11-18	Qi Han 2015-11-18
B	ECN2022112	UPDATE FRAME	Abner 2022-07-20	Staven 2022-07-20	Sam 2022-07-20

A

B

C

D

A

B

C

D

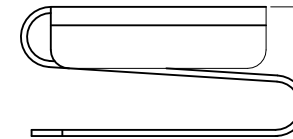
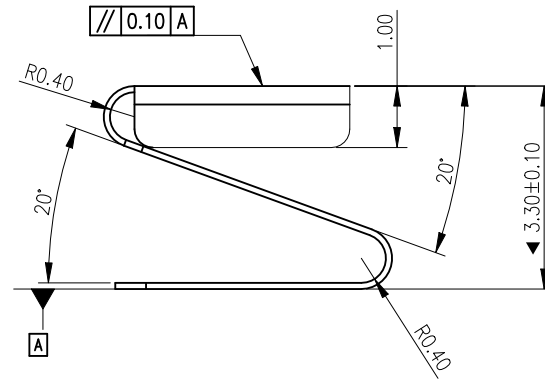
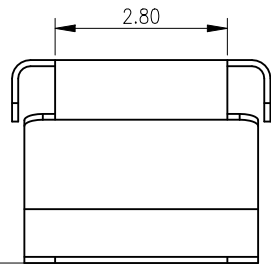

Recommended pressing stroke

Working position: 1.2 MAX

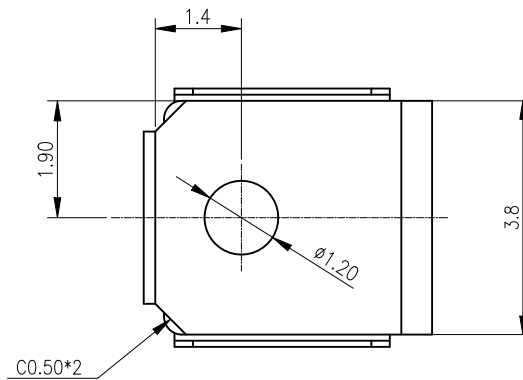

NOTES:

1. MATERIAL: SUS 304-H T=0.10mm;
2. BURR: 0.03mm MAX.
3. PLATING: GOLD FLASH SURFACE PLATING OVER CONTACT AREAS, GOLD FLASH SURFACE PLATING OVER SOLDER AREAS, Ni 40-120u" UNDER PLATING OVER ALL.
4. ALL MATERIAL MUST BE COMPLY WITH RoHS2.0

UNLESS OTHERWISE SPECIFIED TOLERANCES				ANGLE OF PROJECTION		Amphenol AORORA	
X.	±0.30	X. *	± 5'			Amphenol Aorora Technology (Huizhou) Co.,Ltd	
X.X	±0.25	X.X *	± 4'				
X.XX	±0.20	X.XX *	± 3'	Customer Drw		TITLE: SPRING H3.3	
X.XXX	±0.15	X.XXX *	± 2'	DOC TYP	DATE	Abner	2022-07-20
LINEAR DIMS		ANGLES DIMS		DRAWN	DATE	Abner	2022-07-20
DWG NO.: A-S0334				DESIGN	DATE	Abner	2022-07-20
MATERIAL		SEE NOTES		CHECKED	DATE	Staven	2022-07-20
FINISHED		SEE NOTES		APPROVED	DATE	Sam	2022-07-20
SIZE	PART NUMBER:		REV.	TITLE: SPRING H3.3			
A4	Z01B-4G7L1-11000-E000		B	SCALE: 1:1 UNIT: mm SHEET 1 OF 1			

1

2

3

4

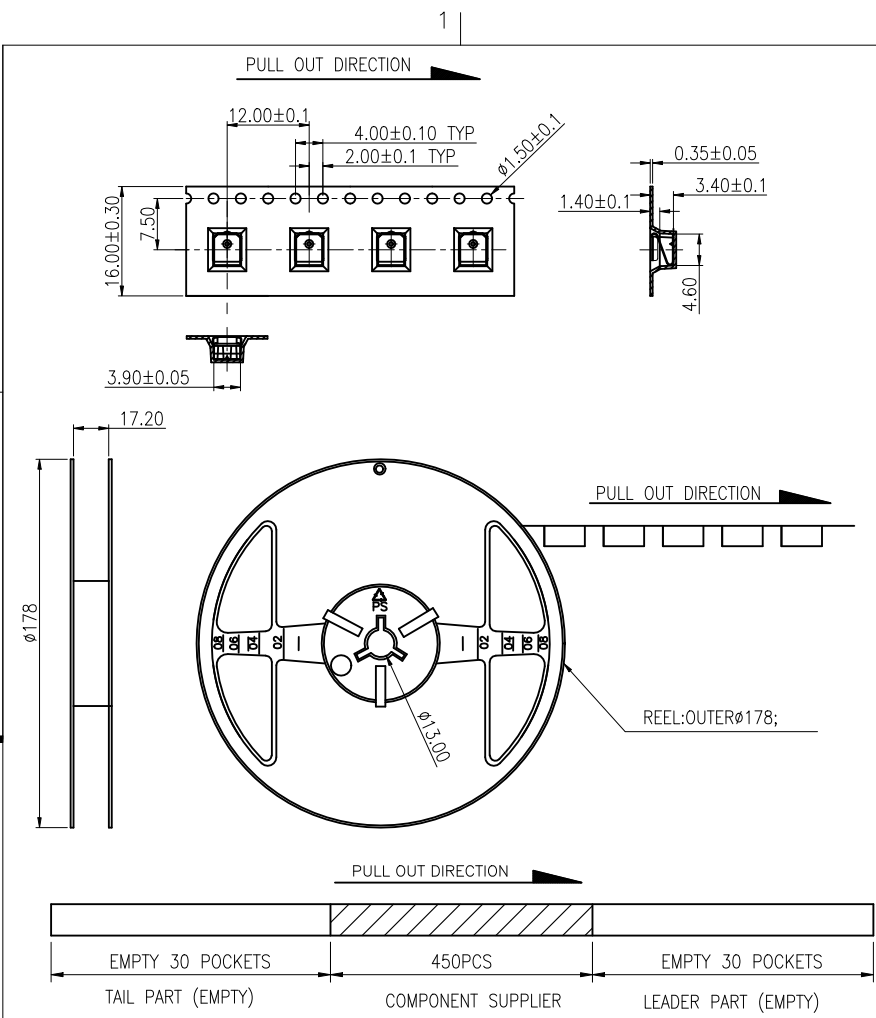

- NOTES:
- MATERIAL:
 - CARRY TAPE:HIPS,T=0.35mm,CLEAR
 - REEL:HIPS,BLUE.
 - SHIM:PE,CLEAR.
 - PRIMARY PACKING:450PCS/REEL.
 - SECONDARY PACKING:"15"REELS/CARTON ("TOTAL"=15*450/CARTON).
 - PEELING RESISTANCE: 0.1N~0.9N(10~90gf);
PEELING ANGLE: 165°~180°;
PEELING SPEED: 300mm/minutes.

PRODUCT	PCS/REEL	inside BOX (TOL:PCS)	outside BOX (TOL:PCS)
Z型端子	450PCS	15REEL(6750PCS)	4 BOX (27000PCS)

REV.	ECR/ECN No.	DESCRIPTION	DRAWN/DATE	CHECKED/DATE	APPROVED/DATE
B		Update package quantity	Staven 2016-08-08	MuYuan Liu 2016-08-08	HongKui Liu 2016-08-08
C	ECN2022112	UPDATE FRAME	Abner 2022-07-20	Staven 2022-07-20	Sam 2022-07-20

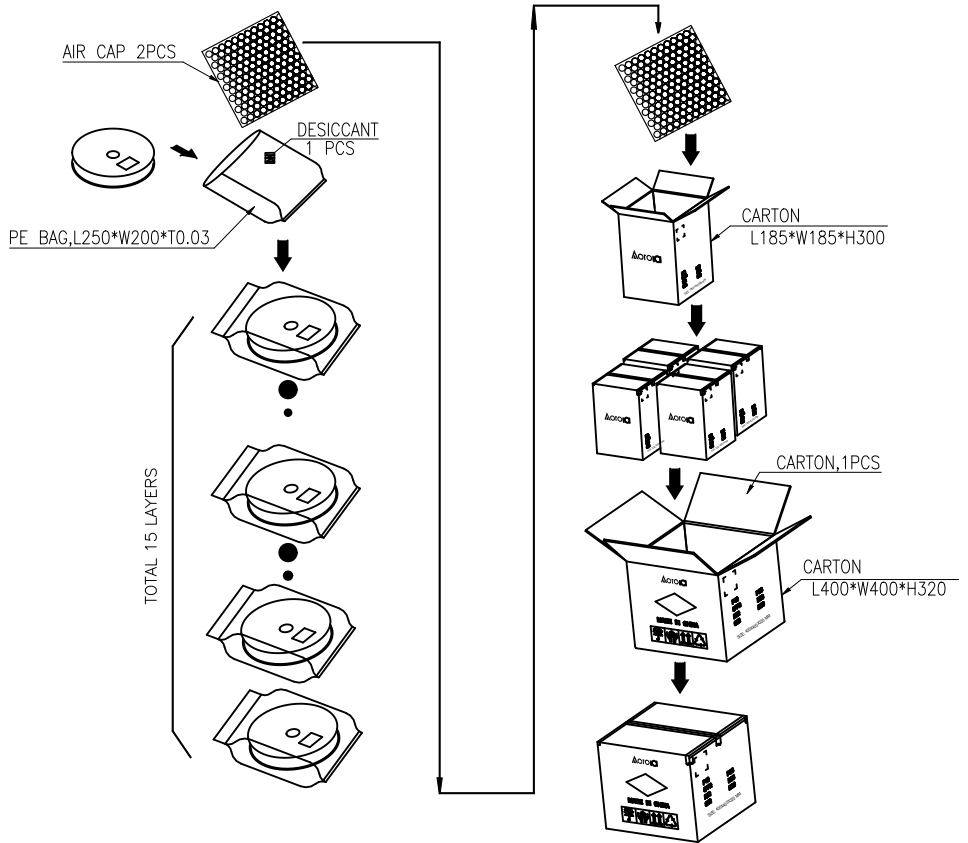

UNLESS OTHERWISE SPECIFIED TOLERANCES				ANGLE OF PROJECTION		Amphenol AORORA	
X.	±0.15	X. °	± 1'			Amphenol Aorora Technology (Huizhou) Co.,Ltd	
X.X	±0.16	X.X °	± 0.5'				
X.XX	±0.05	X.XX °	± 0.5'	DOC TYPE		TITLE:	
X.XXX	±0.03	X.XXX °	± 1'	PACKING DWG.		SPRING H3.3	
LINEAR DIMS		ANGLES DIMS		DRAWN	DATE	Abner	2022-07-20
DWG NO.:	A-H0183			DESIGN	DATE	Abner	2022-07-20
MATERIAL	SEE NOTES			CHECKED	DATE	Staven	2022-07-20
FINISHED	SEE NOTES			APPROVED	DATE	Sam	2022-07-20
SIZE	PART NUMBER:		REV.	A4			
SCALE	1:1	UNIT : mm	SHEET	1 OF 1			