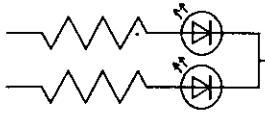
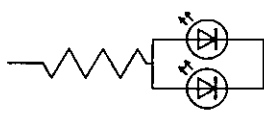

Approved	Checked	Designed	DEVELOPMENT SPECIFICATION					
		T. Tabata	P/N: LNJ816C88RA				TEMPORARY	
T Y P E			Orange Light Emitting Diode					
A P P L I C A T I O N			Indications					
M A T E R I A L			InGaAlP					
O U T L I N E			Attached					
A B S O L U T E M A X I M U M R A T I N G S			P	*1 I _{FP}	I _{FDC}	V _R	Topr	Tstg
			55	60	20	4	-30~+85	-40~+100
			mW	mA	mA	V	°C	°C
C O N D I T I O N			Ta=25±3°C					
Test Specification								
I t e m	Symbol	C o n d i t i o n	Typ	Limit		Unit		
				Min	Max			
Forward Voltage	V _F	I _F =10mA	1.9		2.5	V		
Reverse Leakage Current	I _R	V _R = 3V			100	μA		
Luminous Intensity *2	I _O	I _F =10mA DC	9.8	5.2		mcd		
Peak Emission Wavelength	λ _p	I _F =10mA DC	620			nm		
Spectral Line Half Width	Δλ	I _F =10mA DC	17			nm		
#1. The Condition of I _{FP} is duty 10%, Pulse width 1 ms #2. Tolerance of luminous intensity: ±20%.								
NOTE ★1. Please contact the Panasonic local office if you design at low current (below 1mA DC) or pulse current operation and have any questions. ★2. Soldering conditions...Refer to Handling note. ★3. Compositions of the lead... Cu/Ni/Au plating ★4. Beware of destruction by static electricity in handling the LED. ★5. Circuit to operate LED.								
						(A) Recommended circuit.		
						(B) The difference of brightness between the LED could be found due to the V _F characteristics of each LED.		
Oct. 18. 2001								

Approved	Checked	Designed
		T. Takata

DEVELOPMENT SPECIFICATION

P/N: LNJ816C88RA

TEMPORARY

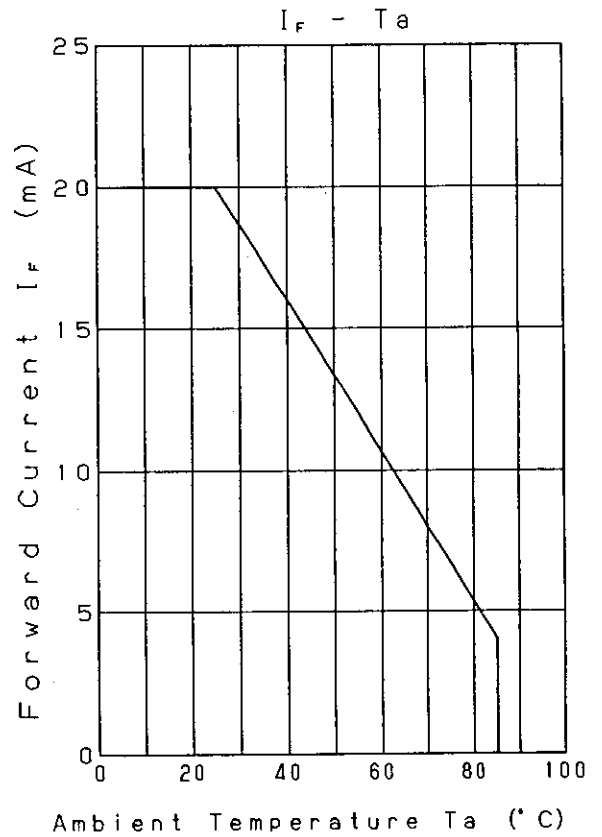
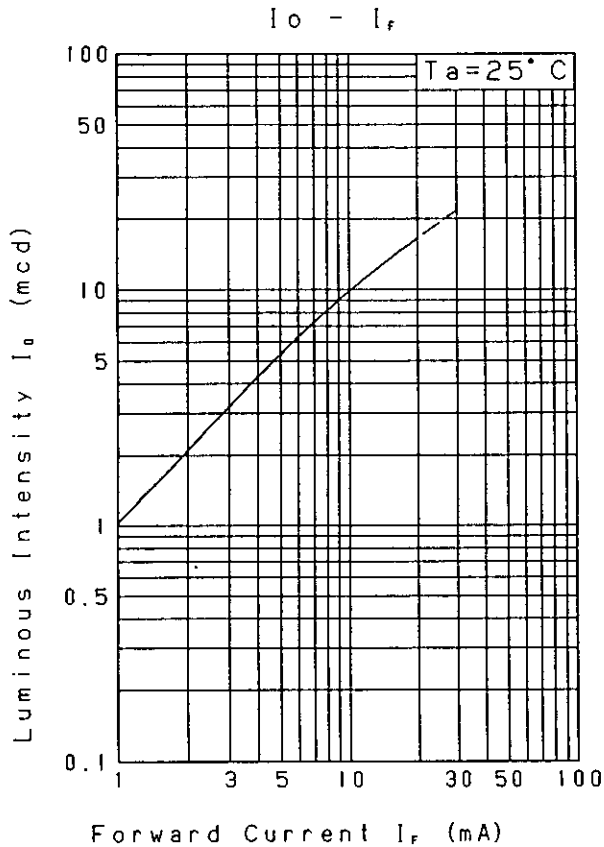
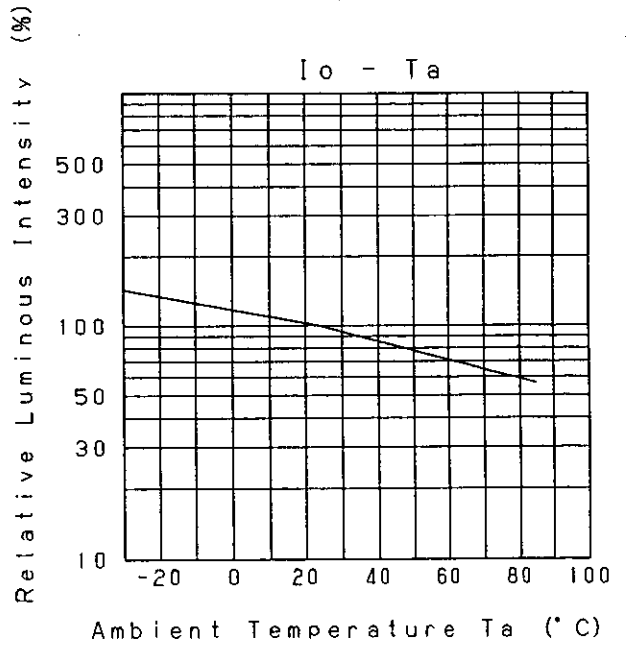
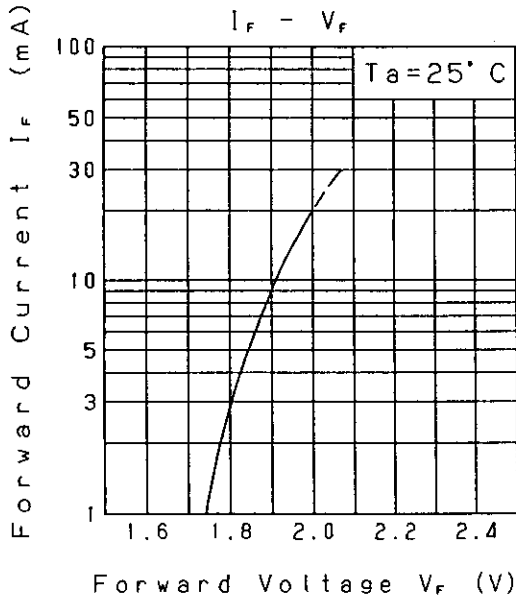

Nov. 7. 2001			
--------------	--	--	--

Approved	Checked	Designed	DEVELOPMENT SPECIFICATION	TEMPORARY
		T. Tabata		

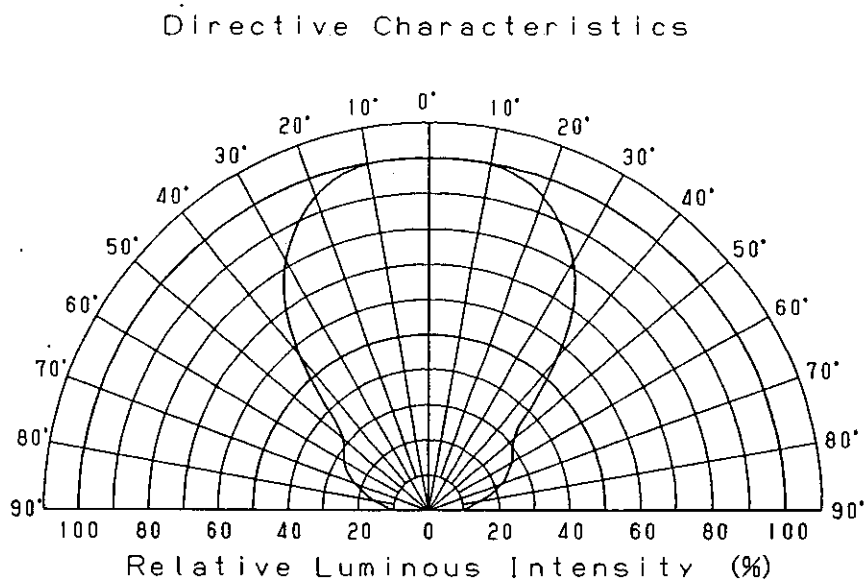
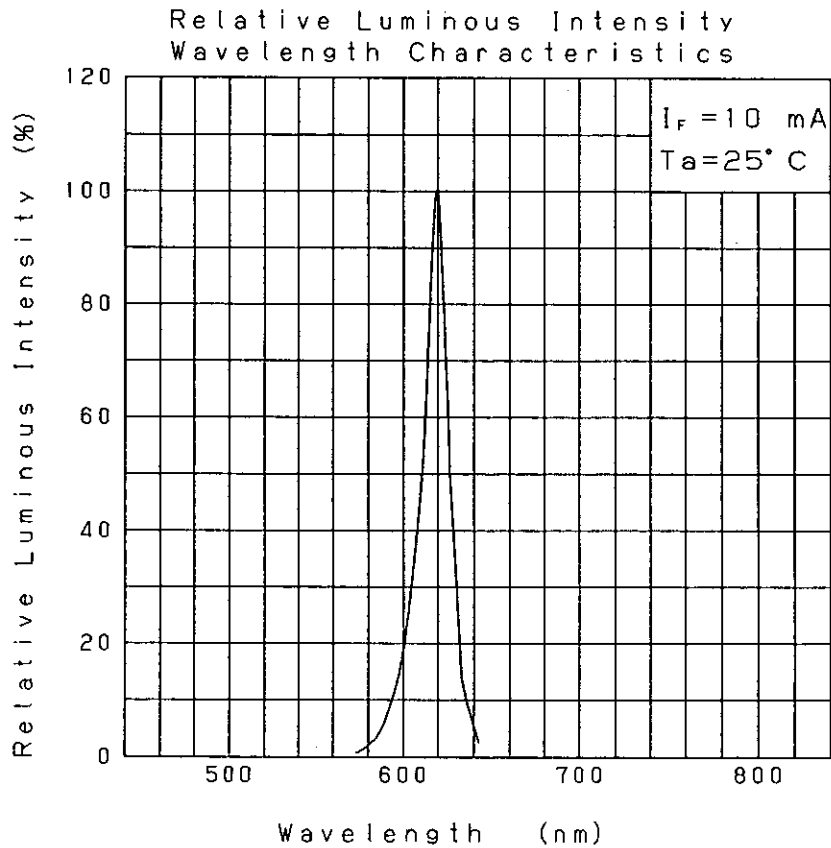

Nov. 7. 2001		

Approved <i>T. Akeda</i>	Checked <i>M. Ni</i>	Designed <i>T. Taketa</i>	DEVELOPMENT SPECIFICATION (OUTLINE) P/N:	

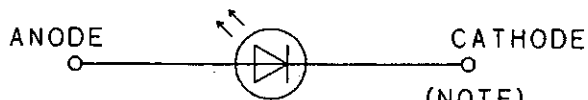
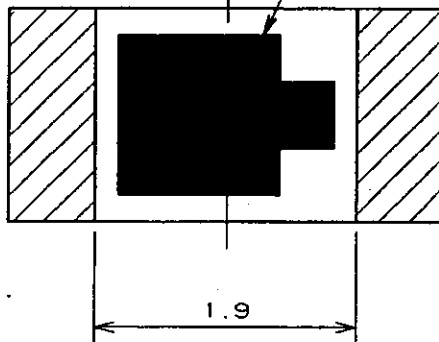
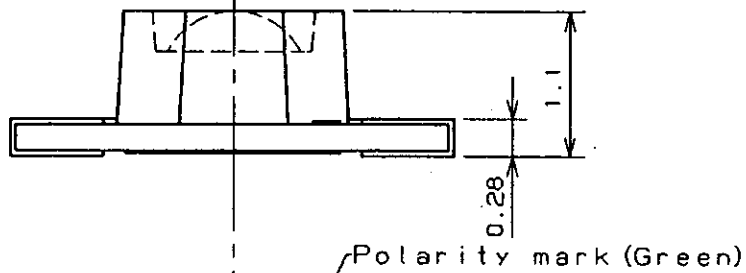
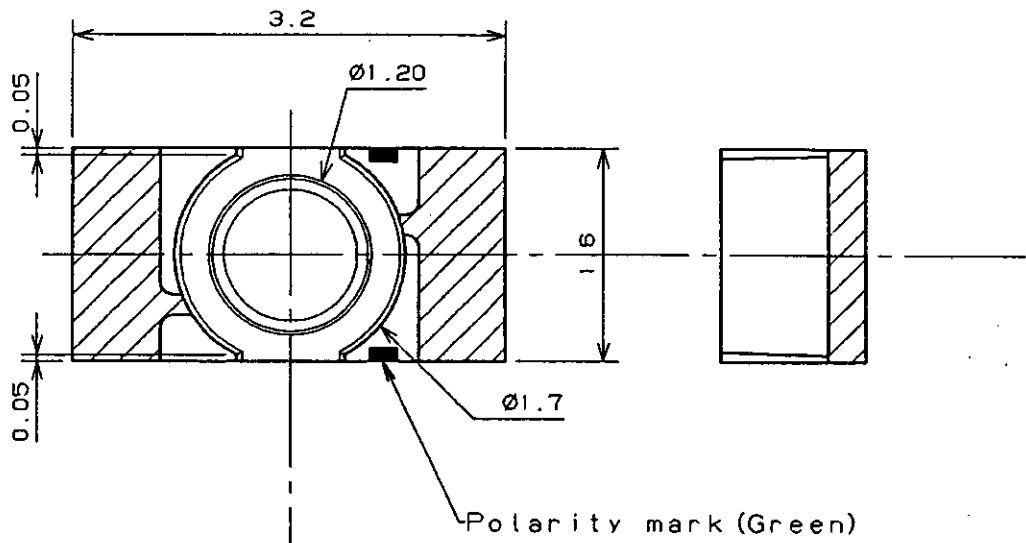

(NOTE)
 1. Unit: mm
 2. Tolerance unless specified is ± 0.15 .
 3. indicate Au terminal.

Jan. 31. 2000			
---------------	--	--	--