

PN# : CCG-EVK-D0

Manual

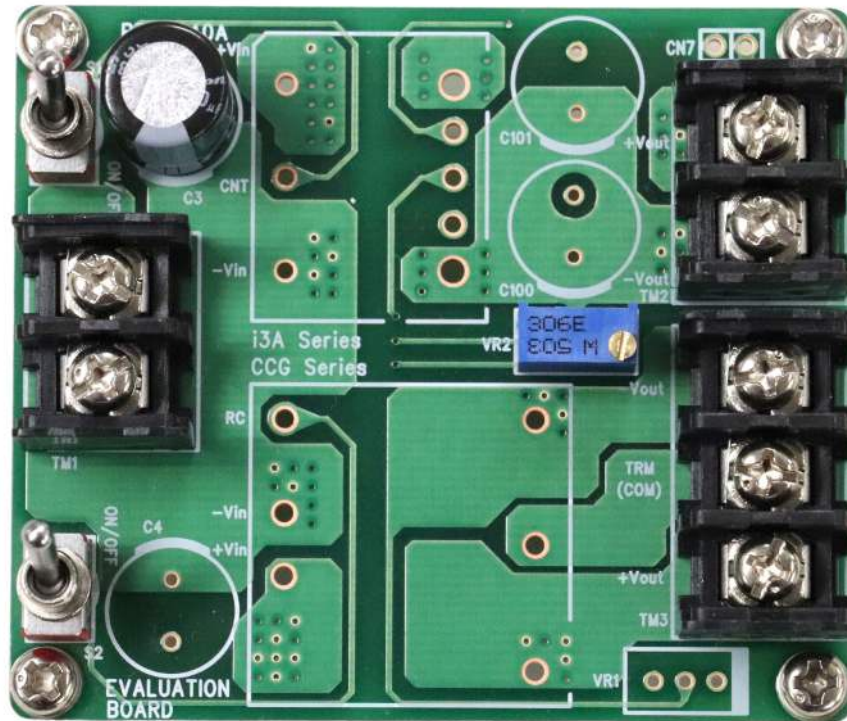

Revision History

Version	Date	Name	Description
-	11/Oct/2019	Naoki Aoyagi	New release
A	10/Dec/2019	Naoki Aoyagi	Replacing photos, Change PN# / Description

Contents

Revision History	1
1 Overview	3
2 Outline	4
3 Instructions	4
3.1 Terminal description and terminal connection method	4
3.2 Input Voltage Range.....	5
3.3 Variable output voltage range	6
3.4 Remote ON/OFF control	6
3.5 Output derating	7
3.6 MLCC connection points	7
4 Component layout	8
5 Schematic and Component list.....	9

1 Overview

This evaluation board (PN#: CCG-EVK-D0) is being provided as a tool to facilitate a quick and easy way to mount and test the CCG15 and CCG30 Series (single or dual output isolated modules). The same evaluation board also comes with a dedicated slot for an i3A Series non-isolated module which allows for a multi output test board configuration. It takes advantage of the wide output adjustability of the i3A series through the provided on board potentiometer.

Given the multiple output configurations offered on the CCG Series and i3A series, the evaluation board does not come with any modules mounted on it. This allows the user to select and request the specific modules that will fit the application needs. Consult the datasheet and/or contact Technical Support.

Caution on Use

- This evaluation board is designed to check the operation of i3A series and CCG series. Therefore, it is not designed to consider electrical characteristics, safety, reliability, and EMI characteristics, so be careful when evaluating.
- This evaluation board does not have a fuse. Please use an external fuse to improve safety. For details on fuse selection, refer to the technical data (instruction manual) for the i3A series and CCG series.
- The maximum input voltage depends on the combination of i3A series and CCG series installed. For details, please refer to Section 3.2 Input Voltage Range.
- Please use the input voltage, output current, output power, temperature derating should be kept within the specifications of i3A series and CCG series. If the product is used outside the specifications, the product may be damaged. For details, refer to the technical data (specifications / instruction manual) for the i3A series and CCG series.
- Do not use in abnormal state such as smoke, smell or sound noise.
- Keep your face and hands away from the product while the power supply is operating. There is a risk of injury due to unexpected situation.
- Do not touch the evaluation board and power supply during operation and immediately after disconnecting input. Since there are high voltage and high temperature components, there is a risk of electric shock and burns.

2 Outline

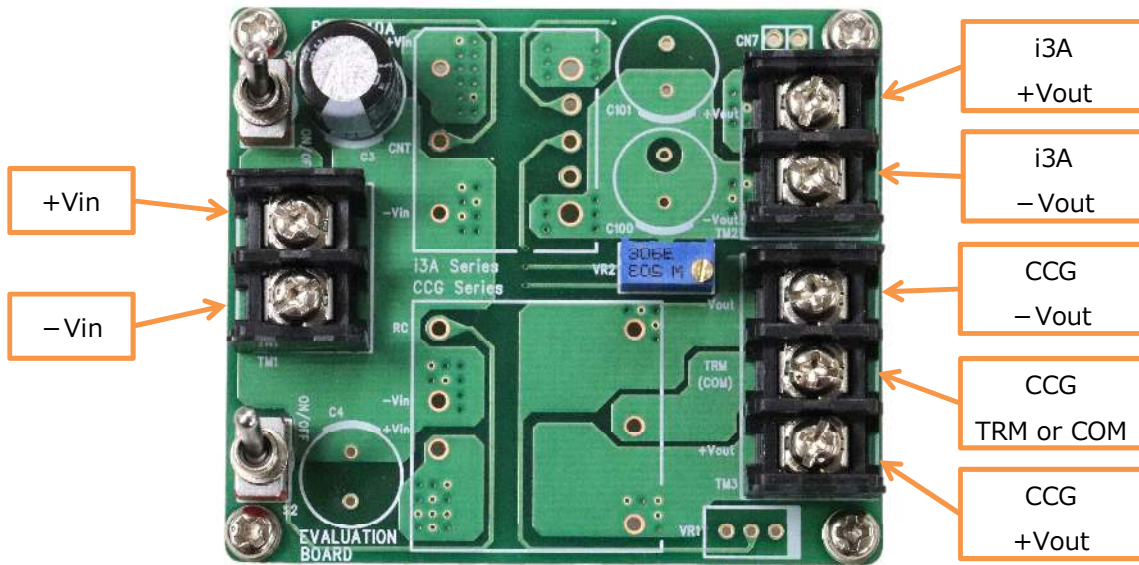

Fig.2-1 Outline

3 Instructions

3.1 Terminal description and terminal connection method

In order to use this evaluation board, it must be connected as shown in Fig.3-1. Incorrect connection may damage the power supply.

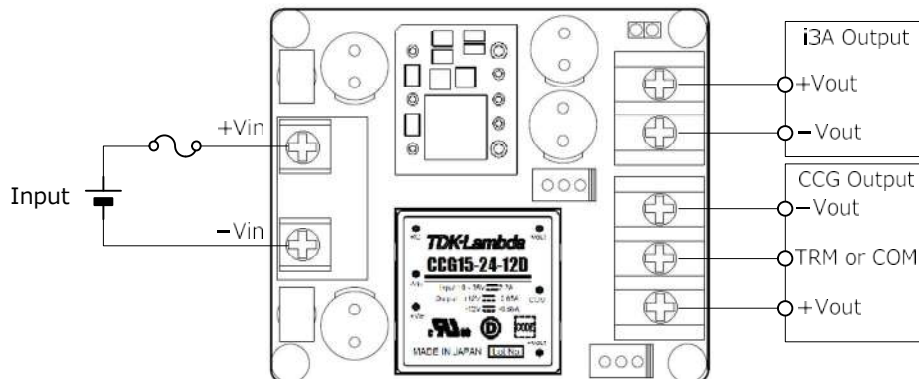

Fig.3-1 Terminal connection method

3.2 Input Voltage Range

The input voltage range is as follows.

Avoid applying voltage exceeding the specified range as it may cause damage.

i3A series only

Input voltage range : 9 ~ 53VDC

CCG-24-*** only**

Input voltage range : 9 ~ 36VDC

CCG-48-*** only**

Input voltage range : 18 ~ 76VDC

i3A series + CCG-24-*****

Input voltage range : 9 ~ 36VDC

(*Note) The maximum input voltage of the i3A series is 53VDC, but the maximum input voltage is 36VDC because CCG **-24-*** is mounted on the evaluation board.

i3A series + CCG-48-*****

Input voltage range : 9 ~ 53VDC

(*Note) The minimum input voltage of CCG **-48-*** is 18VDC.

(*Note) The maximum input voltage of CCG **-48-*** is 76VDC, but the i3A series is mounted on the evaluation board, so the maximum input voltage is 53VDC.

3.3 Variable output voltage range

The output voltage of the i3A series can be varied within the following range.

i3A4W008A033V-001-R : 3.3V ~ 16.5V

i3A4W005A150V-001-R : 5.0V ~ 30V

When changing the output voltage of the i3A series, adjust with the variable volume resistor of VR2. Turning it clockwise increases the voltage, and turning it counterclockwise decreases the voltage.

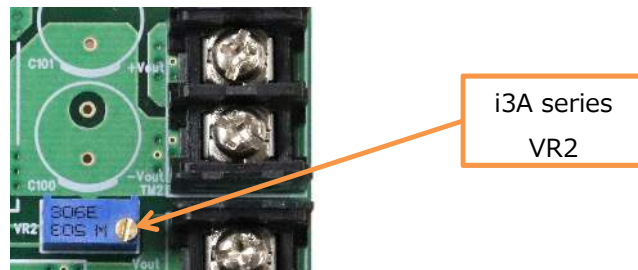

Fig.3-2 i3A variable output volume resistor

i3A series is a step-down converter. The output voltage should be 4V lower than the input voltage.

When the output voltage is increased, reduce the output current to the value specified by the maximum output power.

Note that the maximum output current cannot be increased even if the output voltage is decreased.

3.4 Remote ON/OFF control

By using a switch, ON/OFF control of the output voltage can be performed.

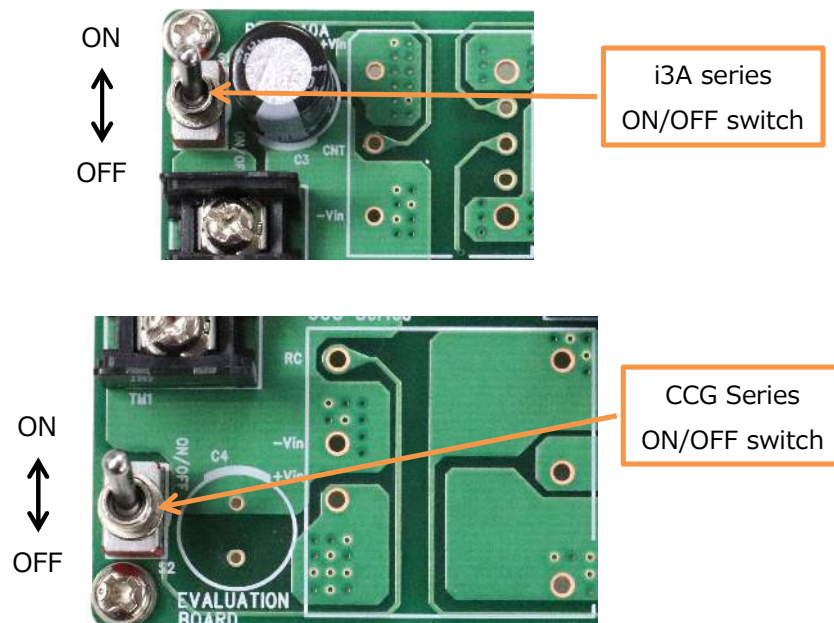

Fig.3-3 i3A/CCG ON/OFF switch

3.5 Output derating

Please use with sufficient consideration of air convection so that heat does not accumulate around this evaluation board. Use a fan so that a wind of 2m/s can pass through this evaluation board at room temperature.

For the output derating measurement method for the i3A series and CCG series, refer to the output derating measurement method in the technical data instruction manual.

3.6 MLCC connection points

Depending on the number of CCG outputs, please change the MLCC connection location as indicated below. Please observe proper soldering techniques and precautions.

CCG**-**-****S** (Single Output Module)

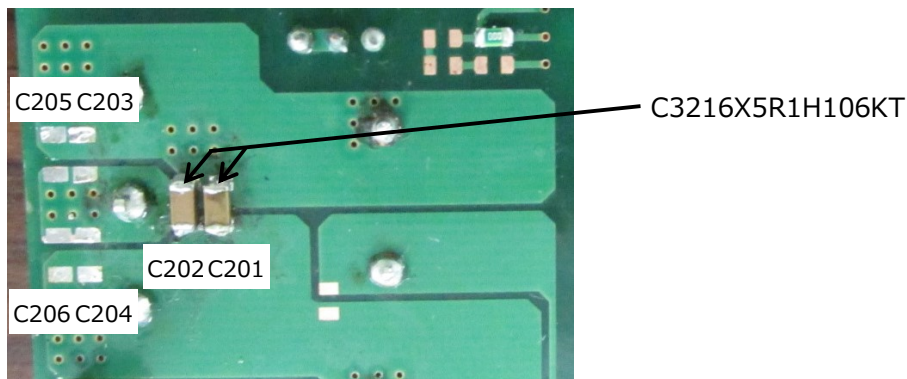

Please connect C3216X5R1H106KT to C201 and C202.

And, make sure nothing is mounted on C203, C204, C205, C206.

CCG**-**-****D** (Dual Output Module)

>> This is the default configuration of the CCG-EVK-D0 Evaluation Board.

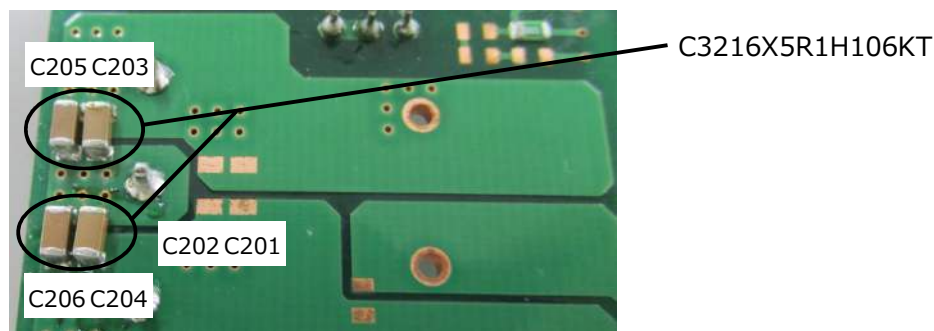

Please connect C3216X5R1H106KT to C203, C204, C205 and C206.

4 Component layout

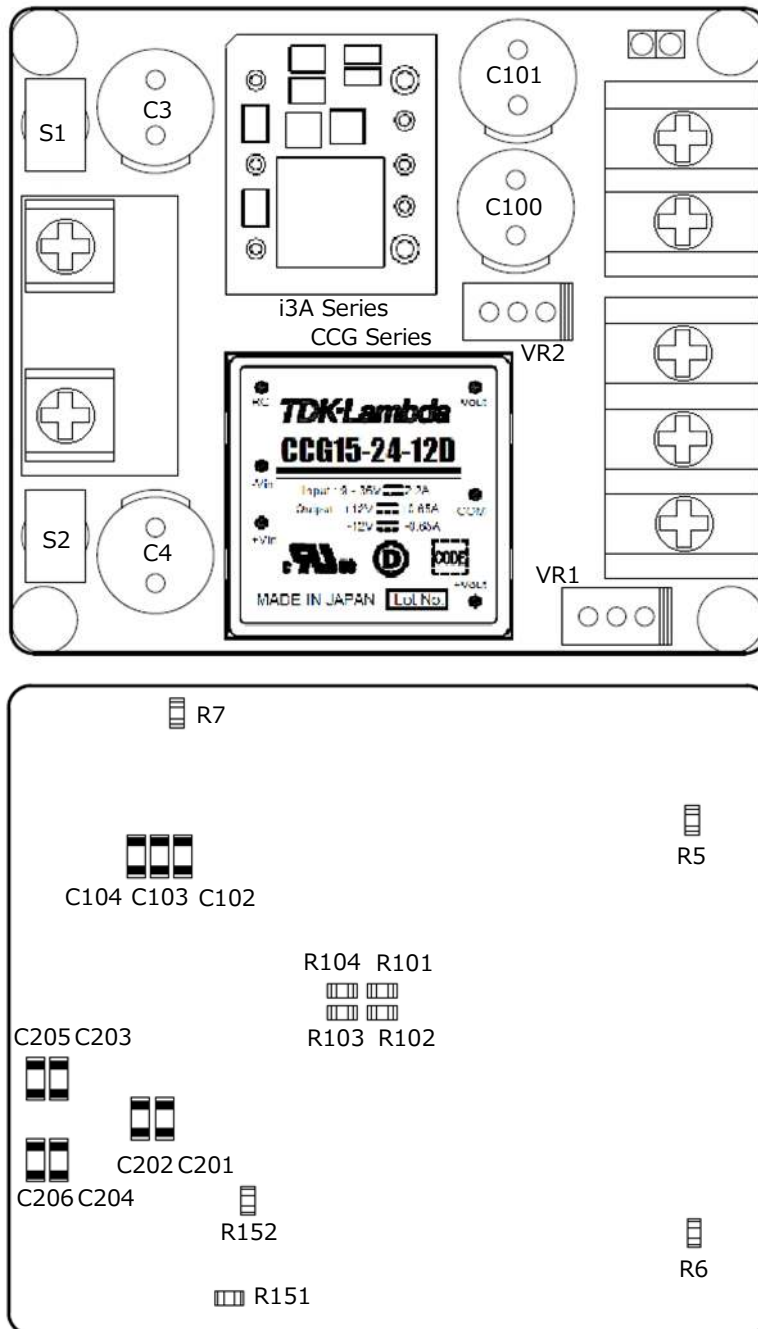

Fig.4-1 Component layout

NOTE:

Not all component locations are populated. Please check the Component List provided.

5 Schematic and Component list

The schematic is shown in Fig.5-1, and the component list is shown in Table 5-1.

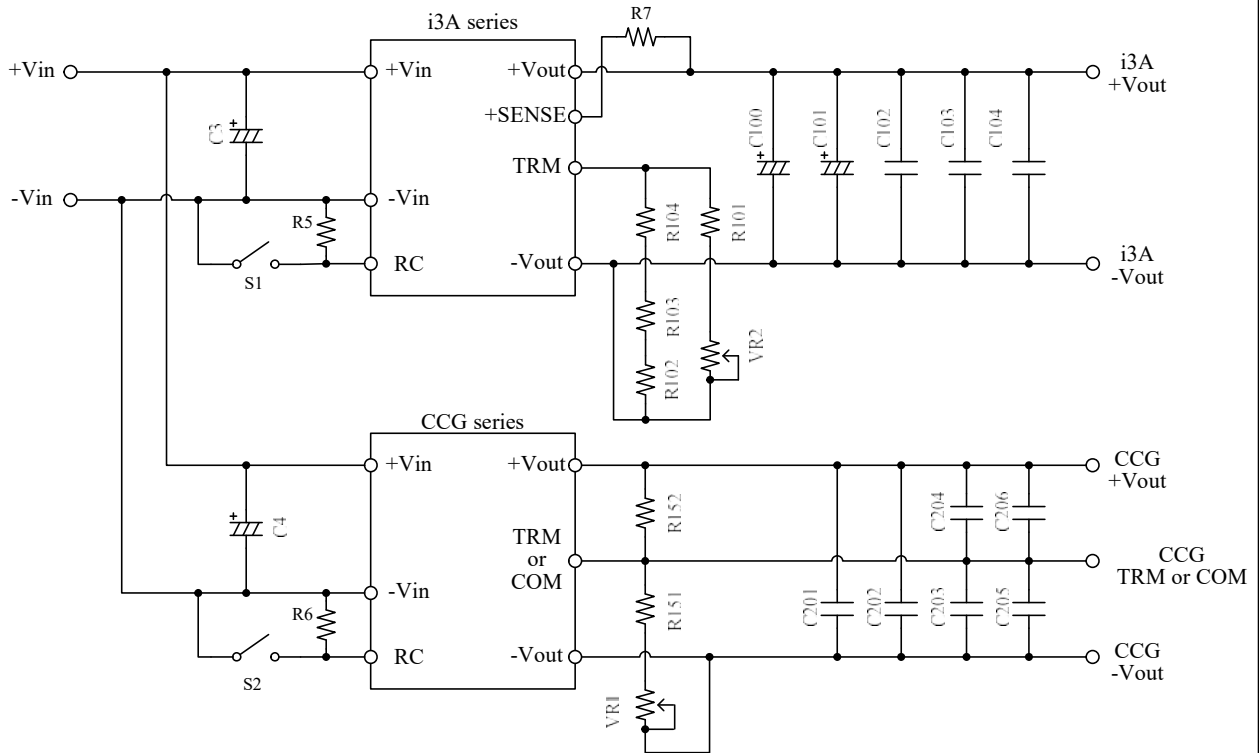

Fig.5-1 Schematic

NOTE:

Not all component locations are populated. Please check the Component List provided.

Table 5-1 Component list

Symbol	Product type	Item Description	Note
C3	Electrolytic Cap.	80ZLH120MEFC10X16	80V 120uF
C4		Not Installed	
C100		Not Installed	
C101		Not Installed	
C102	Ceramic Cap.	C3216X5R1H106KT	50V 10uF
C103	Ceramic Cap.	C3216X5R1H106KT	50V 10uF
C104	Ceramic Cap.	C3216X7R2J102KT	630V 1000pF
C201		Not Installed	
C202		Not Installed	
C203	Ceramic Cap.	C3216X5R1H106KT	50V 10uF
C204	Ceramic Cap.	C3216X5R1H106KT	50V 10uF
C205	Ceramic Cap.	C3216X5R1H106KT	50V 10uF
C206	Ceramic Cap.	C3216X5R1H106KT	50V 10uF
R5		Not Installed	
R6		Not Installed	
R7	Res., Chip	RK73Z2ATTD	0Ω
R101	Res., Chip	RK73Z2ATTD	0Ω
R102		Not Installed	
R103		Not Installed	
R104		Not Installed	
R151		Not Installed	
R152		Not Installed	
VR1		Not Installed	
VR2	Helical Potentiometer	TSR-3296	50kΩ
S1	Toggle Switch	2MS1-T1-B4-M2-Q-E	
S2	Toggle Switch	2MS1-T1-B4-M2-Q-E	