

REVISIONS				
P	LTR	DESCRIPTION	DATE	APVD
	R4	REVISED PER ECN-22-156403	03JUN2022	RK CSD

<b>AMP</b> WIRE RANGE	Listed	LR7189 Certified
22-16 AWG SOLID OR STRANDED	22-16 AWG SOLID OR STRANDED	22-16 AWG SOLID OR STRANDED

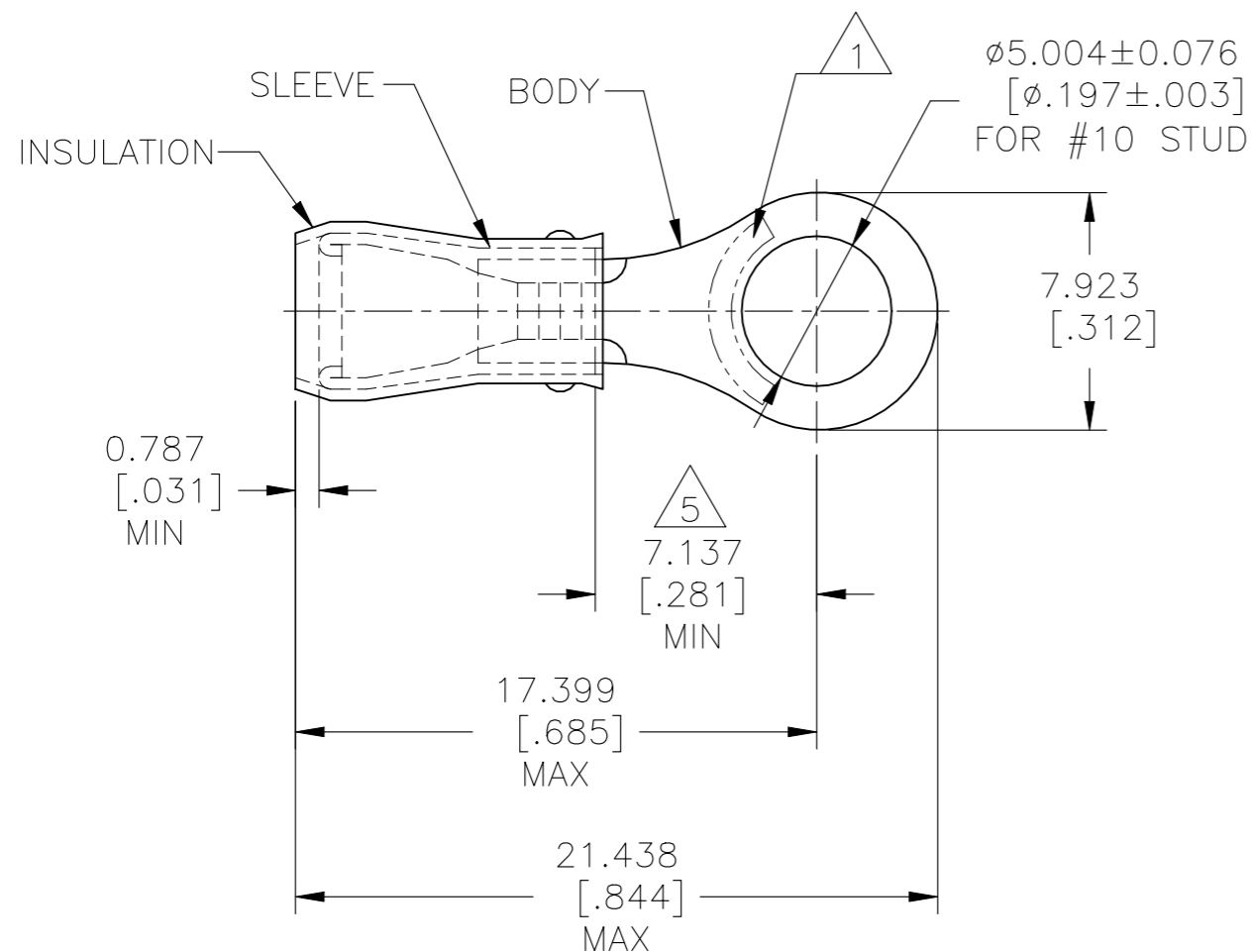

- 1 STAMP AMP 22-18\* APPROX AS SHOWN  
22-16 TERMINALS ARE STAMPED 22-18 IN ACCORDANCE WITH MILITARY SPEC SAE AS7928  
COMMERCIAL WIRE RANGE IS 22-16
- 2 WIRE INSUL,  $\phi 2.667-3.556$  [ $\phi .105-.140$ ]
- 3 BODY MATERIAL THK,  $0.787 \pm 0.051$  [ $.031 \pm .002$ ]
- 4 NOTE DELETED.
- 5 APPLIES FROM CENTER OF STUD HOLE TO EDGE OF METAL WIRE BARREL.

-	50	LOOSE PIECE, BAG	8-36154-5
-	100	LOOSE PIECE, BOX	8-36154-1
-	5000	ON TAPE, REEL	2-36154-2
MS 25036-103 CLASS 1	1000	LOOSE PIECE	36154
MILITARY P/N AND CLASS	QUANTITY	PACKAGE TYPE	PART NO

<b>AMP INCORPORATED CUSTOMER SERVICE SYSTEMS</b>		MAX RECOMMENDED OPERATING TEMPERATURE: 105°C [221°F]	THIS DRAWING IS A CONTROLLED DOCUMENT.		DWN DK SCHRUM 02/16/93	TE Connectivity			
FOR ADDITIONAL PRODUCT INFORMATION OR COPIES OF DRAWINGS AND TECHNICAL DOCUMENTS	PRODUCT INFORMATION CENTER 1-800-522-6752	VOLTAGE RATING: 300 V MAX	DIMENSIONS: mm [INCHES]	TOLERANCES UNLESS OTHERWISE SPECIFIED:	CHK RE HERSEY 4/28/93				
FOR APPLICATION TOOLING INFORMATION	TOOLING ASSISTANCE CENTER 1-800-722-1111	WIRE CROSS SECTIONAL AREA RANGE: 0.26-1.65mm <sup>2</sup> [509-3,260] CIR MILS SOLID OR STRANDED		0 PLC ± - 1 PLC ± - 2 PLC ± - 3 PLC ± 0.127[.005] 4 PLC ± - ANGLES ± -	APVD ML ELLIS 4/28/93	PRODUCT SPEC UL 486 A-B			
FOR ORDER ENTRY	1-800-526-5142		MATERIAL BODY & SLEEVE: COPPER ASTM B-152 INSULATION: NYLON PER D4066	FINISH BODY & SLEEVE: TIN PLATE PER ASTM B 545 INSULATION: RED	APPLICATION SPEC 114-2157				
CUSTOMER DRAWING					WEIGHT -	SCALE 4:1		SHEET 1 OF 1	REV R4