

Ratings

Voltage: 600 V
 Temperature: -40~105 °C
 Flammability: FT2

Conductor

Conductor count: 9
 Gauge: 28 AWG 0.08 mm²
 Material: tinned copper strands
 Strand size: $\phi 0.12 \times 7$
 Resistance at 20 °C: 250 Ω /km max

Insulator

Material: mPPE
 Color: red, black, white, yellow, blue, green, orange, purple, gray
 Diameter: $\phi 0.9 \pm 0.08$ mm
 Average thickness: 0.25 mm
 Minimum thickness: 0.2 mm
 Resistance at 20 °C: 100 M Ω /km min

Shield

Type: foil
 Material: aluminum mylar
 Coverage: 100%

Filler

Material: cotton rope

Outer jacket

Material: mPPE, 85A
 Color: black
 Diameter: $\phi 5 \pm 0.20$ mm
 Average thickness: 0.82 mm
 Minimum thickness: 0.57 mm

Wire marking: E339579 UL AWM STYLE 21509 28 AWG 105°C 600V --- cUL AWM I A 105°C 600V FT2 TENSILITY

Bend radius

Minimum: 6 times diameter (30 mm)

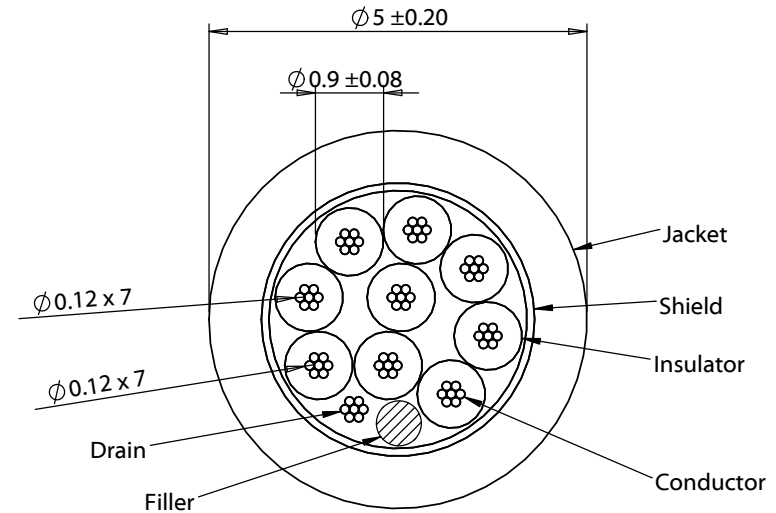
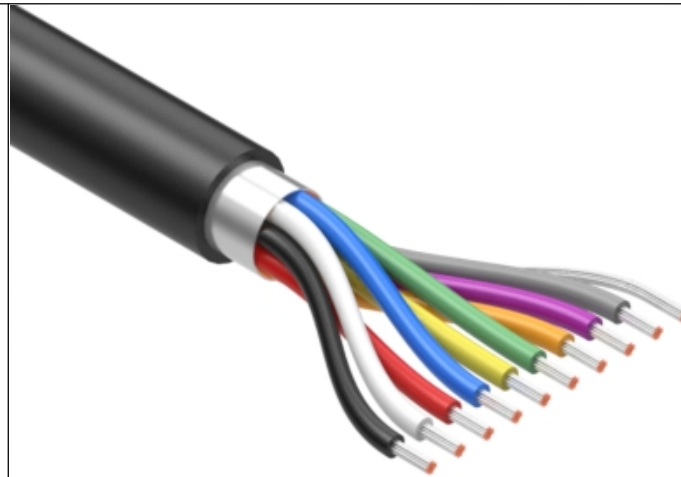

Revision:	Date:	Description:	Prepared: AW <small>Digitally signed by AW Date: 2020.04.20 15:55:26 -0700'</small>	Notes:	<h1>TENSILITY</h1> tel 1.541.323.3228 800 877.670.7118 fax 1.541.323.4202 web tensility.com
A	4/20/2020	Initial release	Verified: JC <small>Digitally signed by JC Date: 2020.04.21 16:38:07 -0700'</small>	RoHS compliant Phthalate and halogen free	
			Dimensions are in millimeters. Tolerances: X: ± 0.5 mm X.X: ± 0.3 mm X.XX: ± 0.05 mm	Description:	Size: Part number:
				Wire, 9C TS, 28 AWG, 21509, 600V, 105C, 5 mm, shielded, FT2, mPPE	A 30-01524
				Scale: 10:1	Sheet 1 of 1

5

4

3

2

1