

NOTE :

- MATERIAL :  
 HOUSING : NYLON GLASS FILLED , BLACK,UL94V-0  
 TERMINAL : COPPER ALLOY THICKNESS = 0.2 MM  
 SHIELD CASE : STAINLESS STEEL THICKNESS = 0.3 MM
- PLATING :  
 TERMINAL:  
 CONTACT AREA : GOLD 0.76 MICROMETER MINIMUM,  
 SOLDER TAIL AREA : MATTE TIN 3.8 MICROMETER MIN.  
 UNDER PLATING : NICKEL 1.27 MICROMETER MINIMUM.  
 SHIELD CASE :  
 2.5-4 MICROMETER SOLDERABLE NICKLE PLATING.
- TAIL & NAIL COPLANARITY 0.08 mm MAXIMUM.
- PRODUCT SPEC: PS-47153-001.
- PACKAGE INFORMATION: PER PK-47153-001.
- COMPLIANT TO RoHS DIRECTIVE 2002/95/EC AND ELV DIRECTIVE 2000/53/EC.

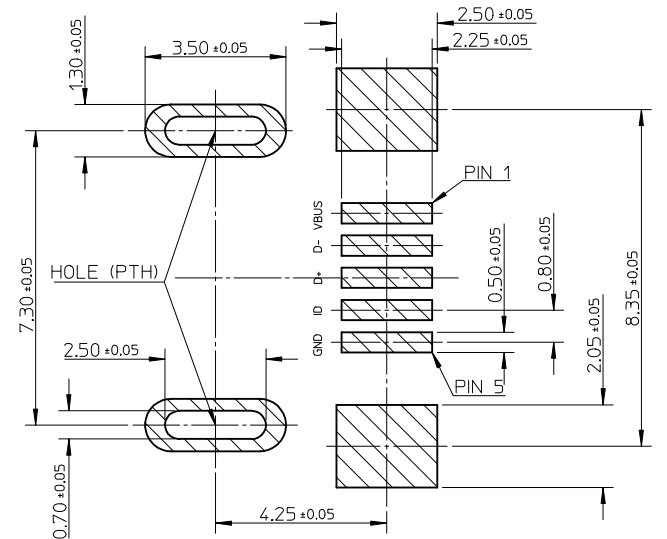
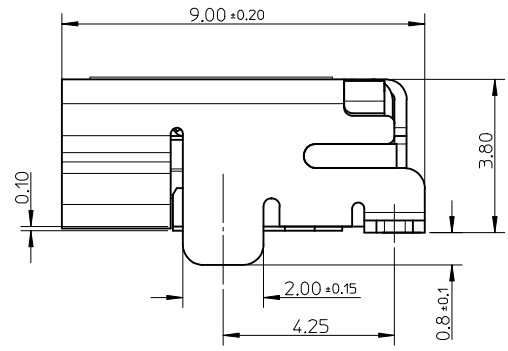
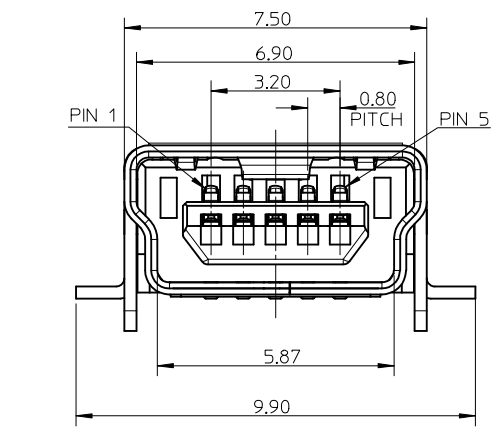

RECOMMENDED P.C.B PATTERN LAYOUT

REVISE EC NO: 2007/11/19 DRWN:XJSONG CHKD: 2007/11/20 APPR:HWANG 2007/11/28	DESCRIPTION REV	QUALITY SYMBOLS ▽=0 ◻=0	GENERAL TOLERANCES (UNLESS SPECIFIED)		DIMENSION STYLE MM ONLY		SCALE 1:1	DESIGN UNITS METRIC	THIRD ANGLE PROJECTION			
			mm	INCH	DRAWN BY	DATE	TITLE					
			4 PLACES	± ---	± ---	XJSONG	2006/05/09	USB SERIES MINI-B REC. ASS'Y DIP TYPE LEAD FREE				
			3 PLACES	± ---	± ---	CHECKED BY	DATE					
		2 PLACES	± 0.25	± ---	IWANG	2006/05/09	MOLEX INCORPORATED					
		1 PLACE	± 0.25	± ---	APPROVED BY	DATE						
		ANGULAR ± 3 °			JNCHEN	2006/05/09	MATERIAL NO. 47153-1002		DOCUMENT NO. SD-47153-002			
DRAFT WHERE APPLICABLE MUST REMAIN WITHIN DIMENSIONS			SIZE A3		THIS DRAWING CONTAINS INFORMATION THAT IS PROPRIETARY TO MOLEX INCORPORATED AND SHOULD NOT BE USED WITHOUT WRITTEN PERMISSION							