

OLED Character Displays

Issue 04.2022

Controller similar HD44780 4-/8-bit, SPI

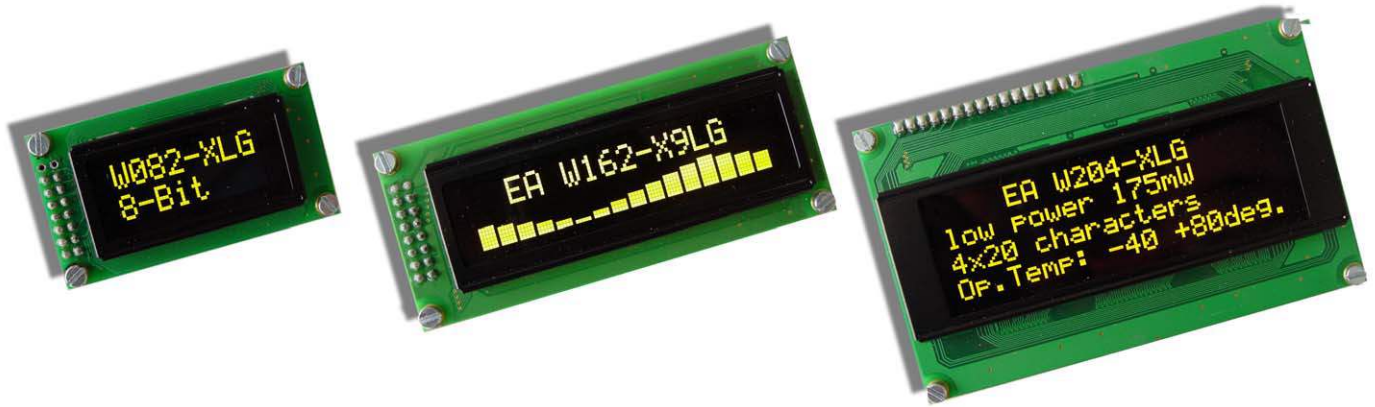

OLED										
Part-Number	Row x Column	Char height	Module size			Viewing Area		Accessories (Frames)	Hints	Drawing page
			W	H	D	W	H			
EA W082-XLG	2x8	5.5	58.0	32.0	10.0	38.0	16.0	---	yellow/green	8
EA W162-X3LW	2x16	5.5	80.0	36.0	10.0	66.0	16.0	EA 017-2U	icewhite	9
EA W162-X3LG	2x16	5.5						EA 017-2U	yellow/green	9
EA W162-XLG	2x16	5.5	84.0	44.0	10.0	66.0	16.0	EA 017-2U	yellow/green	10
EA W162-X9LG	2x16	5.5	85.0	36.0	10.0	66.0	16.0	EA 017-2U	yellow/green	11
EA W162-XBLW	2x16	8.9	122.0	44.0	10.0	99.0	24.0	EA 017-12U	icewhite	12
EA W162-XBLG	2x16	8.9						EA 017-12U	yellow/green	12
EA W202-XLG	2x20	5.5	116.0	37.0	9.8	85.0	18.6	EA 017-7U	yellow/green	13
EA W204-XLG	4x20	5.5	98.0	60.0	10.0	70.0	25.2	EA 017-9U	yellow/green	14

TECHNICAL DATA

- * INTEGRATED CONTROLLER (HD44780-LIKE)
- * INPUT 4- OR 8-BIT DATA-BUS, 3 CONTROL-WIRES(R/W, E, RS)
- * SPI INTERFACE MOSI, MISO, CLK, CS
- * ASCII-CHAR SET AND SPECIAL SYMBOLS STORED IN CHARACTER-ROM
- * UP TO 8 CHARACTERS (ASCII-CODE 0..7) CAN BE DEFINIED BY USER
- * DIFFERENT FUNCTIONS WITH ONE INSTRUCTION:
 - CLEAR DISPLAY, CURSOR HOME, CURSOR ON/OFF, BLINKING CURSOR
 - SHIFT DISPLAY, SHIFT CURSOR, READ/WRITE DISPLAY DATA, ETC.
- * SIMPLE SUPPLY (3.3..5V).
- * LOW POWER CONSUMPTION (15..50 mA)
- * OPERATING TEMPERATURE -40..+80°C
- * 4 INTEGRATED FONTS

ACCESSORIES

- * FRAMES (SEE TABLE)

OLED Character Displays

It is possible to choose one of the shown char sets. The English/Japanese char set is setted by default . You have to set the bits FT1/FT0 of function set register:

FT 1	FT 0	Description
0	0	Englisch Japanese character font table
0	1	Western European character font table 1
1	0	English Russian character font table
1	1	Western European character font table 2

It must be noted that the character font setting must be performed at the head of the program before executing any instructions other than the Busy Flag and Address Instruction. Otherwise, the Function Set Instruction cannot be executed unless the interface data length is changed.

SELF DEFINIED CHARACTER

All these character display modules got the feature to create 8 own characters (ASCII Codes 0..7) in addition to the ROM fixed codes.

1.) The command „CG RAM Address Set“ defines the ASCII code (Bit 3,4,5) and the dot line (Bit 0,1,2) of the new character. Example demonstrates creating ASCII code \$00.

2.) Doing 8 times the write command „Data Write“ defines line by line the new character. 8th. byte stands for the cursor line.

3.) The new defined character can be used as a „normal“ ASCII code (0..7); use with „DD RAM Address Set“ and „Data Write“.

Adresse im CG RAM setzen			Daten des Zeichens								
Adresse	Hex		Bit								
			7	6	5	4	3	2	1	0	Hex
0 0 0	\$40									0 0 1 0 0	
0 0 1	\$41									0 0 1 0 0	\$04
0 1 0	\$42									0 0 1 0 0	\$04
0 1 1	\$43									0 0 1 0 0	\$04
0 1 0 0 0	\$44									1 0 1 0 1	\$15
	\$45									0 1 1 1 0	\$0E
	\$46									0 0 1 0 0	\$04
	\$47									0 0 0 0 0	\$00

INSTRUCTION SET

Instruction	Code										Description	Max. execution time when fsp or fosc=250KHz	
	RS	R/W	DB7	DB6	DB5	DB4	DB3	DB2	DB1	DB0			
Clear Display	0	0	0	0	0	0	0	0	0	1	Clears entire Display, Sets DDRAM-address 0 into addresscounter	6.2ms	
Return Home	0	0	0	0	0	0	0	0	0	1	Sets DDRAM-address 0 into addresscounter. Returns shifted display to original position. DDRAM contents remain unchanged.	0ms	
Entry Mode Set	0	0	0	0	0	0	0	0	1	I/D	S	Sets cursor move direction and specifies display shift.(These operations are performed during data write and read.)	0ms
Display On/Off Control	0	0	0	0	0	0	0	1	D	C	B	Sets entire Display (D) ON/OFF. Sets Cursor (C) ON/OFF. Sets Blinking (B) of Cursor Position Character.	0ms
Cursor/Display Shift/Mode/Pwr	0	0	0	0	0	1	S/C	R/L	0	0	Moves cursor and shifts display w without changing DDRAM contents.	0ms	
							G/C (0)	PWR	1	1	Sets Graphic/Character Mode Sets internal power on/off	0ms	
Function Set	0	0	0	0	1	DL	N	F	FT1	FT0	Sets interface data length (DL). Sets number of display lines (N). Sets Character Font (F). Sets Font Table (FT).	0ms	
Set CGRAM Address	0	0	0	1	ACG	ACG	ACG	ACG	ACG	ACG	Sets CGRAM Address. CGRAM data is sent and received after this setting.	0ms	
Set DDRAM Address	0	0	1	ADD	ADD	ADD	ADD	ADD	ADD	ADD	Sets DDRAM Address. The DDRAM data is sent and received after this setting.	0ms	
Read Busy Flag and Address	0	1	BF	AC	AC	AC	AC	AC	AC	AC	Reads Busy Flag (BF) indicating that internal operation is being performed. Reads Address Counter contents.	0ms	
Write data into the CGRAM or DDRAM	1	0	Write Data								Writes data into the CGRAM or DDRAM	0ms	
Read data from the CGRAM or DDRAM	1	1	Read Data								Reads data from the CGRAM or DDRAM	0ms	

Notes on the instruction set:

- After the CGRAM/DDRAM Read or Write Instruction has been executed, the RAM Address Counter is incremented or decremented by 1. After the Busy Flag is turned OFF, the RAM Address is updated.
- I/D**=Increment/Decrement Bit
I/D="1": Increment
I/D="0": Decrement
- S**=Shift Entire Display Control Bit.
S="0", shift function disable.
S="1", shift function enable.
- BF**=Busy Flag
BF="1": Internal Operating in Progress
BF="0": No Internal Operation is being executed, next instruction can be accepted.
- R/L**=Shift Right/Left
R/L="1": Shift to the Right
R/L="0": Shift to the Left
- S/C**=Display Shift/Cursor Move
S/C="1": Display Shift
S/C="0": Cursor Move
- G/C**=Graphic/Character mode selection.
G/C="0", Character mode is selected.
G/C="1", Graphic mode is selected.
- PWR**=Internal DCDC on/of control.
PWR="1", DCDC on.
PWR="0", DCDC off.
- DDRAM**=Display Data RAM
- CGRAM**=Character Generator RAM
- ACG**=CGRAM Address
- ADD**=Address Counter Address (corresponds to cursor address)
- AC**=Address Counter (used for DDRAM and CGRAM Addresses)
- F**=Character Pattern Mode
F="1": 5 x 10 dots
F="0": 5 x 8 dots
- N**=Number of Lines Displayed
N="1": 2- and 4-Line Display
N="0": 1-Line Display

INITIALISATION EXAMPLES

Initialisation example: 8-Bit / SPI											
RS	R/W	DB7	DB6	DB5	DB4	DB3	DB2	DB1	DB0	HEX	Description
0	0	0	0	1	1	1	0	0	1	\$39	Function Set, western european character set, 8-Bit
0	0	0	0	0	0	1	0	0	0	\$08	Display off
0	0	0	0	0	0	0	1	1	0	\$06	Entry mode set, increment cursor by 1 not shifting display
0	0	0	0	0	1	0	1	1	1	\$17	Character mode and internal power on (have to turn on internal power to get the best brightness)
0	0	0	0	0	0	0	0	0	1	\$01	Clear display
0	0	0	0	0	0	0	0	1	0	\$02	Return home
0	0	0	0	0	0	1	1	0	0	\$0C	Display on

```
void initDisplay(void)
{
    RS_DD=1; //RS Pin as output
    RW_DD=1; //RW Pin as output
    EN_DD=1; //EN Pin as output
    WriteIns(0x39); //function set european character set
    WriteIns(0x08); //display off
    WriteIns(0x06); //entry mode set increment cursor by 1 not shifting display
    WriteIns(0x17); //Character mode and internal power on
    WriteIns(0x01); //clear display
    WriteIns(0x02); //return home
    WriteIns(0x0C); //display on
}
```

```
void WriteIns(char instruction)
{
    CheckBusy();
    DATA_PORT_DD=0xFF; //Dataport as Output
    RS = 0;
    RW = 0;
    DATA_PORT = instruction; //set Data on Outputport
    EN = 1; //set Enable to high
    Wait(10); //wait 1us (stabilize Outputport)
    EN = 0; //reset Enable to low
}
```

Initialisation example: 4-Bit											
RS	R/W	DB7	DB6	DB5	DB4	DB3	DB2	DB1	DB0	HEX	Description
0	0	0	0	1	0	1	0	0	0	\$28	Function Set, English/Japanese char set, 4-Bit Note: Western European charset not available
0	0	0	0	0	0	1	0	0	0	\$08	Display off
0	0	0	0	0	0	0	1	1	0	\$06	Entry mode set, increment cursor by 1 not shifting display
0	0	0	0	0	1	0	1	1	1	\$17	Character mode and internal power on (have to turn on internal power to get the best brightness)
0	0	0	0	0	0	0	0	0	1	\$01	Clear display
0	0	0	0	0	0	0	0	1	0	\$02	Return home
0	0	0	0	0	0	1	1	0	0	\$0C	Display on

```
void initDisplay(void)
{
    RS_DD=1; //RS-Pin as Output
    EN_DD=1; //EN-Pin as Output
    RW_DD=1; //RW-Pin as Output
    RS = 0; //RS-Pin to low
    RW = 0; //RW-Pin to low
    EN = 0; //EN-Pin to low
    send_nibble(0x03); //Be sure to
    send_nibble(0x03); //be in
    send_nibble(0x03); //8-Bit-Mode
    send_nibble(0x02); //Switch to 4 Bit
    Wait(50); //Wait 5us
    WriteIns(0x28); //4-Bit-Mode
    WriteIns(0x08); //display off
    WriteIns(0x06); //entry mode set increment cursor by 1 not shifting display
    WriteIns(0x17); //Character mode and internal power on
    WriteIns(0x01); //clear display
    WriteIns(0x02); //return home
    WriteIns(0x0C); //display on
}
```

```
void send_nibble(char data)
{
    DATA_PORT = data; //output data
    EN=1;
    Wait(10); //wait 1us (stabilize output)
    EN=0;
    Wait(10); //wait 1us (stabilize output)
}
```

```
void WriteIns(char instruction)
{
    CheckBusy();
    DATA_PORT_DD=0x0F; //Dataport as Output
    RS = 0;
    RW = 0;
    send_nibble((instruction&0xF0)>>4); //Highbyte
    send_nibble(instruction&0x0F); //Lowbyte
}
```

TIMING 8-BIT INTERFACE

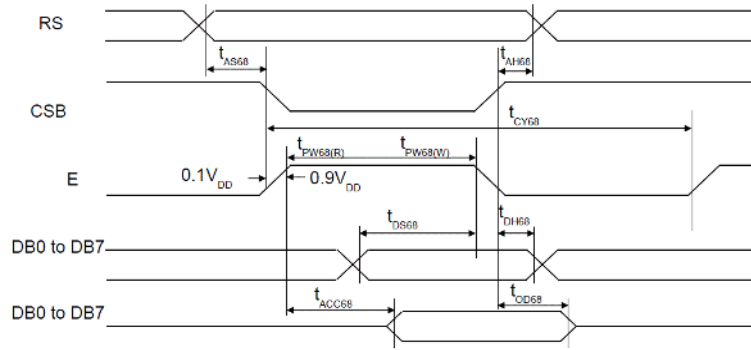

(VDD = 3.0 to 5.3V, Ta = 25°C)

Item	Signal	Symbol	Min.	Typ.	Max.	Unit	Remark
Address setup time	RS	t_{AS68}	20	-	-	ns	
Address hold time	RS	t_{AH68}	0	-	-	ns	
System cycle time		t_{CY68}	500	-	-	ns	
Pulse width (E)	E_RDB	$t_{pw68(W)}$	250	-	-	ns	
Pulse width (E)	E_RDB	$t_{pw68(R)}$	250	-	-	ns	
Data setup time	DB7 to DB0	t_{DS68}	40	-	-	ns	
Data hold time	DB7 to DB0	t_{DH68}	20	-	-	ns	
Read access time	DB0 to DB7	t_{ACC68}	-	-	180	ns	CL = 100pF
Output disable time	DB0 to DB7	t_{OD68}	10	-	-	ns	

ELECTRICAL CHARACTERISTICS

Item	Symbol	Test Condition	Standard Value			Unit
			min.	typ.	max	
Input "high" voltage	V _{IH}	-	0.9 VDD	-	VDD	V
Input "low" voltage	V _{IL}	-	GND	-	0.1 VDD	V
Output "high" voltage	V _{OH}	I _{OH} =-0.5mA	0.8 VDD	-	VDD	V
Output "low" voltage	V _{OL}	I _{OL} =0.5mA	GND	-	0.2 VDD	V
Power supply current	ICC	VDD=5V		15..50mA		A

ABSOLUTE MAXIMUM RATINGS

VCC=5,0V, Ta=25°C

Item	Symbol	Standard Value		Unit
		min.	max	
Power supply voltage for logic	VDD-GND	-0.3	5.3	V
Input Voltage	V _I	-0.3	VDD	V
Operating temperature	TOP	-40	80	°C
Storage Temperature	TST	-40	80	°C

*It must be noted:
Supplied with 3.3V reduces brightness compared to 5V*

OLED Character Displays

SPI INSTRUCTION DIAGRAM

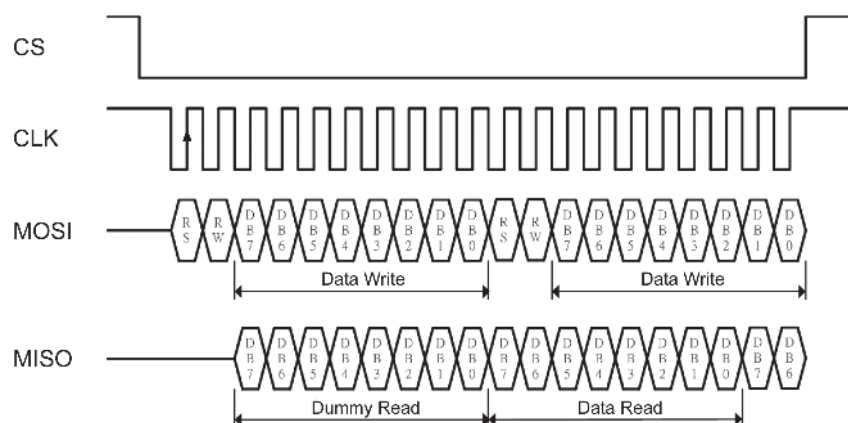

SPI DATA TRANSMISSION DIAGRAM

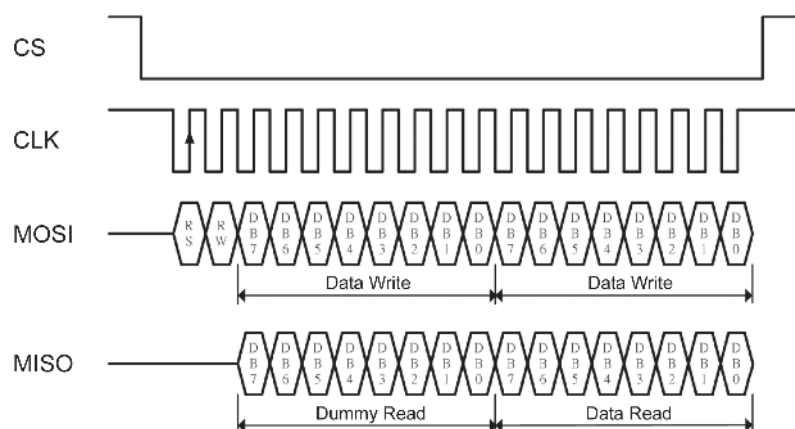

TIMING SPI INTERFACE

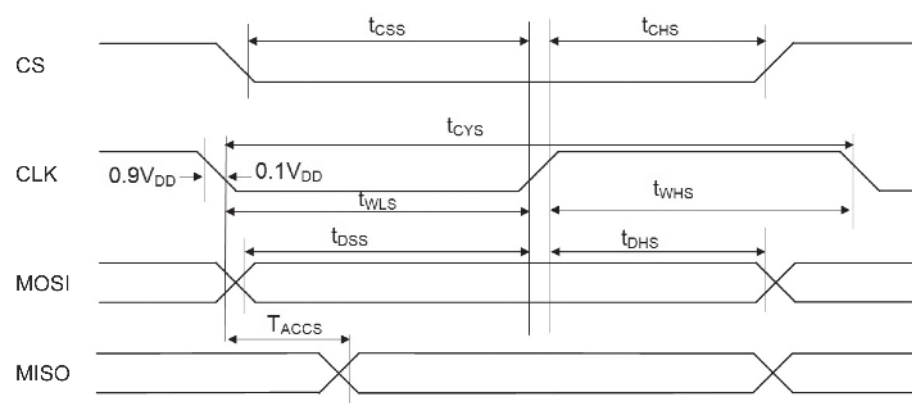

Item	Signal	Symbol	Min.	Typ.	Max.	Unit
Serial clock cycle	CLK	t_{CYS}	300	-	-	ns
SCL high pulse width	CLK	t_{WHS}	100	-	-	ns
SCL low pulse width	CLK	t_{WLS}	100	-	-	ns
CSB setup time	CS	t_{CSS}	150	-	-	ns
CSB hold time	CS	t_{CHS}	150	-	-	ns
Data setup time	MOSI	t_{DSS}	100	-	-	ns
Data hold time	MOSI	t_{DHS}	100	-	-	ns
Read access time	MOSI	t_{Accs}	-	-	80	ns

EA W082-XLG

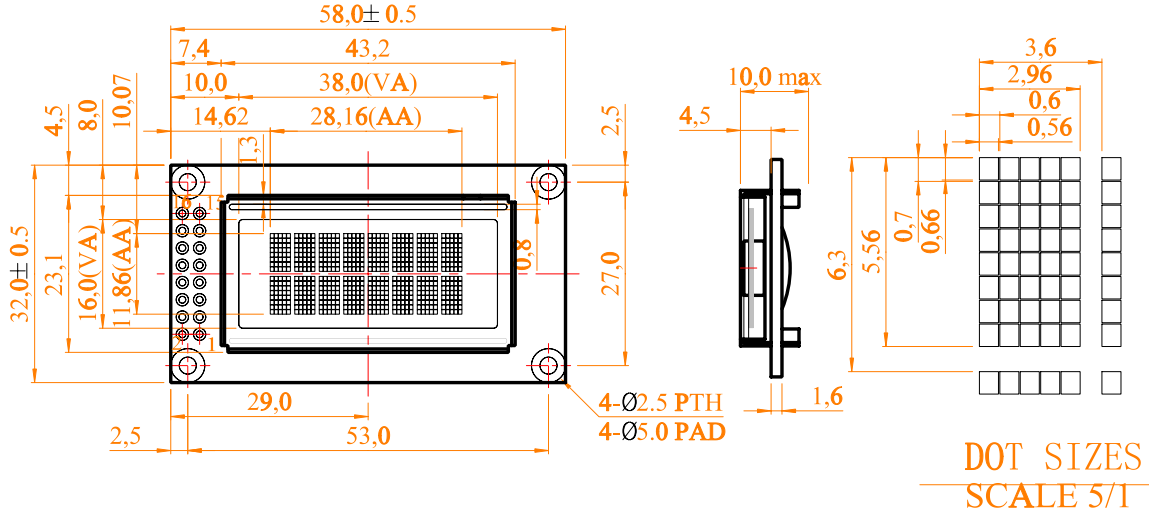

INTERFACE 4-/8-BIT, 6800/ Z80



4-/8-Bit 6800
(default)

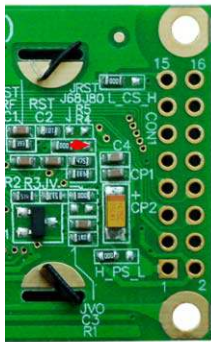

4-/8-Bit Z80

Pinout for 8-Bit Interface			
Pin	Symbol	Level	Description
1	VSS	L	Power Supply 0V, GND
2	VDD	H	Power Supply +3.3V-5V
3	NC	-	Not Connected
4	RS	H / L	Register Select
5	R/W (WR)	H / L (L)	H: Read / L: Write (L: Write, Z80-Mode)
6	E (RD)	H (L)	H: Enable (L: Read, Z80-Mode)
7..14	D0..D7	H / L	Data Bus, bidirectional
15	NC	-	Not Connected
16	NC	-	Not Connected

Pinout for 4-Bit Interface			
Pin	Symbol	Level	Description
1	VSS	L	Power Supply 0V, GND
2	VDD	H	Power Supply +3.3V-5V
3	NC	-	Not Connected
4	RS	H / L	Register Select
5	R/W (WR)	H / L (L)	H: Read / L: Write (L: Write, Z80-Mode)
6	E (RD)	H (L)	H: Enable (L: Read, Z80-Mode)
7..10	DNC	-	Do Not Connect
11..14	D4..D7	H / L	Data Bus, bidirectional
15	NC	-	Not Connected
16	NC	-	Not Connected

SPI INTERFACE



SPI

Pinout for SPI-Bit Interface			
Pin	Symbol	Level	Description
1	VSS	L	Power Supply 0V, GND
2	VDD	H	Power Supply +3.3V-5V
3..11	NC	-	Not Connected
12	CLK	H / L	L-H: Serial Clock
13	MISO	H / L	Serial Data Output
14	MOSI	H / L	Serial Data Input
15	CS	L	L: Chip Select
16	NC	-	Not Connected

In delivery state the display can be connected directly to the 4- or 8-Bit data bus (compatible to 6800 mode). By changing the solder bridges, the mode „Z80“ is set. Additionally the SPI interface can be selected.

For timing information please refer to page 6 and 7.

OLED Character Displays

EA W162-X3LW (ICEWHITE)
EA W162-X3LG (YELLOW/GREEN)

FRAME
EA 017-2U

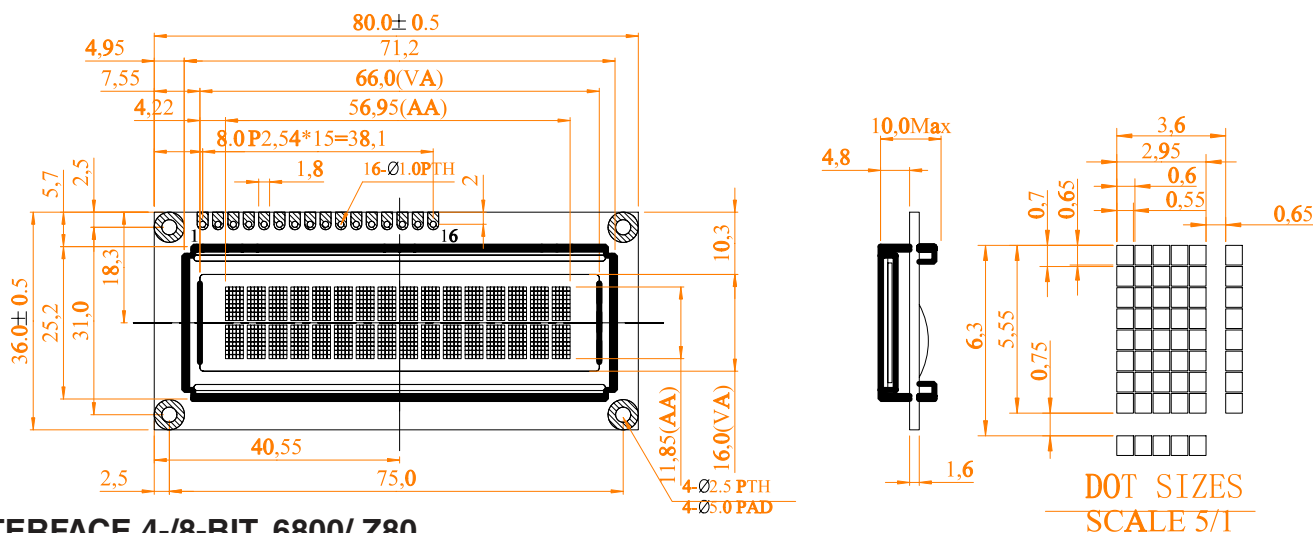

INTERFACE 4-/8-BIT, 6800/ Z80



4-/8-Bit 6800
(Voreinstellung)

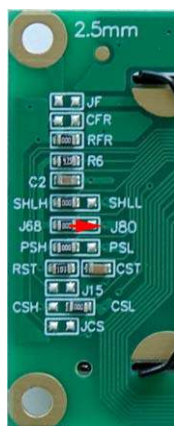

4-/8-Bit Z80

Pinout for 8-Bit Interface			
Pin	Symbol	Level	Description
1	VSS	L	Power Supply 0V, GND
2	VDD	H	Power Supply +3.3V~5V
3	NC	-	Not Connected
4	RS	H / L	Register Select
5	R/W (WR)	H / L (L)	H: Read / L: Write (L: Write, Z80-Mode)
6	E (RD)	H (L)	H: Enable (L: Read, Z80-Mode)
7..14	D0..D7	H / L	Data Bus, bidirectional
15	NC	-	Not Connected
16	NC	-	Not Connected

Pinout for 4-Bit Interface			
Pin	Symbol	Level	Description
1	VSS	L	Power Supply 0V, GND
2	VDD	H	Power Supply +3.3V~5V
3	NC	-	Not Connected
4	RS	H / L	Register Select
5	R/W (WR)	H / L (L)	H: Read / L: Write (L: Write, Z80-Mode)
6	E (RD)	H (L)	H: Enable (L: Read, Z80-Mode)
7..10	DNC	-	Do Not Connect
11..14	D4..D7	H / L	Data Bus, bidirectional
15	NC	-	Not Connected
16	NC	-	Not Connected

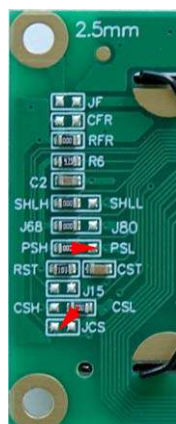

SPI

SPI INTERFACE

Pinout for SPI-Interface			
Pin	Symbol	Level	Description
1	VSS	L	Power Supply 0V, GND
2	VDD	H	Power Supply +3.3V~5V
3..11	NC	-	Not Connected
12	CLK	H / L	L-H: Serial Clock
13	MISO	H / L	Serial Data Output
14	MOSI	H / L	Serial Data Input
15	NC	-	Not Connected
16	CS	L	L: Chip Select

In delivery state the display can be connected directly to the 4- or 8-Bit data bus (compatible to 6800 mode). By changing the solder bridges, the mode „Z80“ is set. Additionally the SPI interface can be selected.

For timing information please refer to page 6 and 7.

EA W162-XLG (YELLOW/GREEN)

FRAME
EA 017-2U

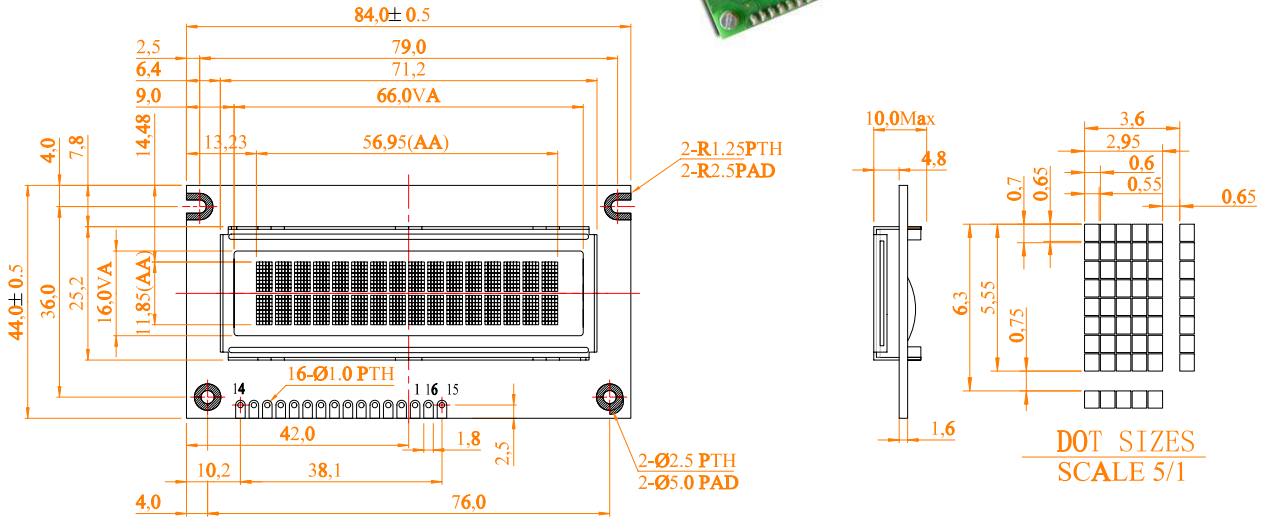

INTERFACE 4-/8-BIT, 6800/ Z80



4-/8-Bit 6800
(default)



4-/8-Bit Z80

Pinout for 8-Bit Interface			
Pin	Symbol	Level	Description
1	VSS	L	Power Supply 0V, GND
2	VDD	H	Power Supply +3.3V-5V
3	NC	-	Not Connected
4	RS	H / L	Register Select
5	R/W (WR)	H / L (L)	H: Read / L: Write (L: Write, Z80-Mode)
6	E (RD)	H (L)	H: Enable (L: Read, Z80-Mode)
7..14	DO..D7	H / L	Data Bus, bidirectional
15	NC	-	Not Connected
16	NC	-	Not Connected

Pinout for 4-Bit Interface			
Pin	Symbol	Level	Description
1	VSS	L	Power Supply 0V, GND
2	VDD	H	Power Supply +3.3V-5V
3	NC	-	Not Connected
4	RS	H / L	Register Select
5	R/W (WR)	H / L (L)	H: Read / L: Write (L: Write, Z80-Mode)
6	E (RD)	H (L)	H: Enable (L: Read, Z80-Mode)
7..10	DNC	-	Do Not Connect
11..14	D4..D7	H / L	Data Bus, bidirectional
15	NC	-	Not Connected
16	NC	-	Not Connected

SPI INTERFACE



SPI

Pinout for SPI-Interface			
Pin	Symbol	Level	Description
1	VSS	L	Power Supply 0V, GND
2	VDD	H	Power Supply +3.3V-5V
3..11	NC	-	Not Connected
12	CLK	H / L	L-H: Serial Clock
13	MISO	H / L	Serial Data Output
14	MOSI	H / L	Serial Data Input
15	NC	-	Not Connected
16	CS	L	L: Chip Select

In delivery state the display can be connected directly to the 4- or 8-Bit data bus (compatible to 6800 mode). By changing the solder bridges, the mode „Z80“ is set. Additionally the SPI interface can be selected.

For timing information please refer to page 6 and 7.

OLED Character Displays

EA W162-X9LG

FRAME
EA 017-2U

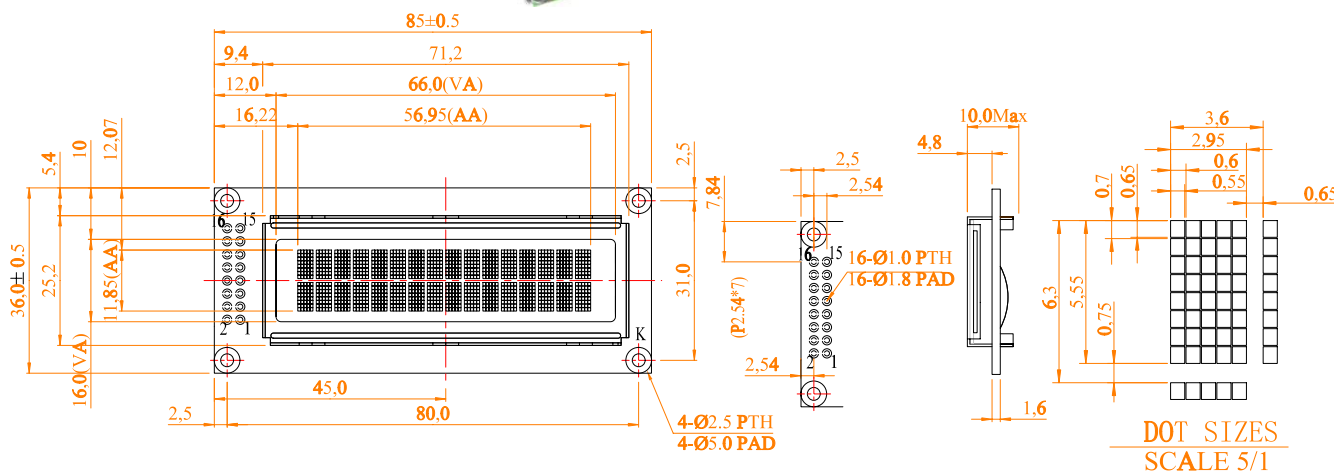

INTERFACE 4-/8-BIT, 6800/ Z80



4-/8-Bit 6800
(default)



4-/8-Bit Z80

Pinout for 8-Bit Interface			
Pin	Symbol	Level	Description
1	VSS	L	Power Supply 0V, GND
2	VDD	H	Power Supply +3.3V~5V
3	NC	-	Not Connected
4	RS	H / L	Register Select
5	R/W (WR)	H / L (L)	H: Read / L: Write (L: Write, Z80-Mode)
6	E (RD)	H (L)	H: Enable (L: Read, Z80-Mode)
7..14	D0..D7	H / L	Data Bus, bidirectional
15	NC	-	Not Connected
16	NC	-	Not Connected

Pinout for 4-Bit Interface			
Pin	Symbol	Level	Description
1	VSS	L	Power Supply 0V, GND
2	VDD	H	Power Supply +3.3V~5V
3	NC	-	Not Connected
4	RS	H / L	Register Select
5	R/W (WR)	H / L (L)	H: Read / L: Write (L: Write, Z80-Mode)
6	E (RD)	H (L)	H: Enable (L: Read, Z80-Mode)
7..10	DNC	-	Do Not Connect
11..14	D4..D7	H / L	Data Bus, bidirectional
15	NC	-	Not Connected
16	NC	-	Not Connected

SPI INTERFACE

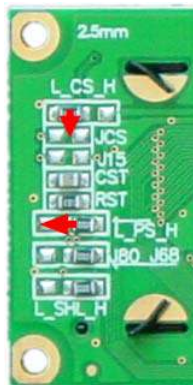

SPI

Pinout for SPI-Interface			
Pin	Symbol	Level	Description
1	VSS	L	Power Supply 0V, GND
2	VDD	H	Power Supply +3.3V~5V
3..11	NC	-	Not Connected
12	CLK	H / L	L-H: Serial Clock
13	MISO	H / L	Serial Data Output
14	MOSI	H / L	Serial Data Input
15	NC	-	Not Connected
16	CS	L	L: Chip Select

In delivery state the display can be connected directly to the 4- or 8-Bit data bus (compatible to 6800 mode). By changing the solder bridges, the mode „Z80“ is set. Additionally the SPI interface can be selected. For timing information please refer to page 6 and 7.

EA W162-XBLW (ICEWHITE)
EA W162-XBLG (YELLOW/GREEN)

FRAME
EA 017-12U

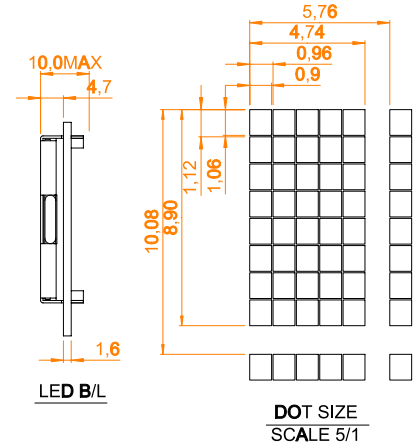
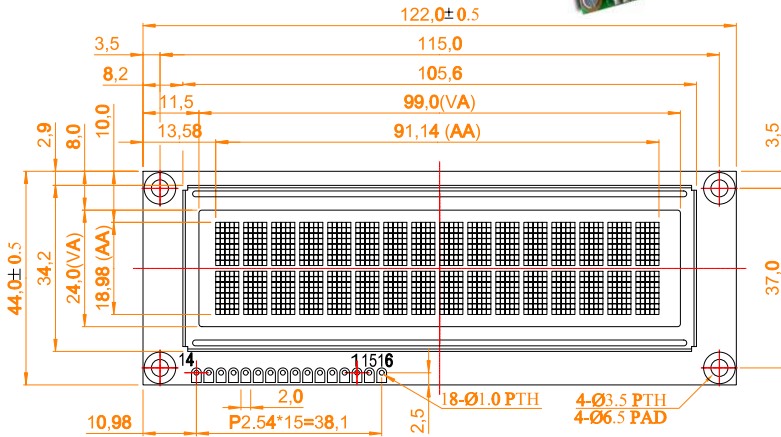

INTERFACE 4-/8-BIT, 6800/ Z80



4-/8-Bit 6800
(default)

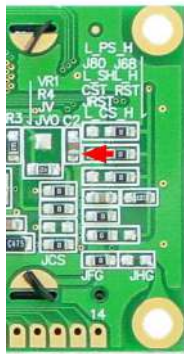

4-/8-Bit Z80

Pinout for 8-Bit Interface			
Pin	Symbol	Level	Description
1	VSS	L	Power Supply 0V, GND
2	VDD	H	Power Supply +3.3V~5V
3	NC	-	Not Connected
4	RS	H / L	Register Select
5	R/W (WR)	H / L (L)	H: Read / L: Write (L: Write, Z80-Mode)
6	E (RD)	H (L)	H: Enable (L: Read, Z80-Mode)
7..14	D0..D7	H / L	Data Bus, bidirectional
15	NC	-	Not Connected
16	NC	-	Not Connected

Pinout for 4-Bit Interface			
Pin	Symbol	Level	Description
1	VSS	L	Power Supply 0V, GND
2	VDD	H	Power Supply +3.3V~5V
3	NC	-	Not Connected
4	RS	H / L	Register Select
5	R/W (WR)	H / L (L)	H: Read / L: Write (L: Write, Z80-Mode)
6	E (RD)	H (L)	H: Enable (L: Read, Z80-Mode)
7..10	DNC	-	Do Not Connect
11..14	D4..D7	H / L	Data Bus, bidirectional
15	NC	-	Not Connected
16	NC	-	Not Connected

SPI INTERFACE

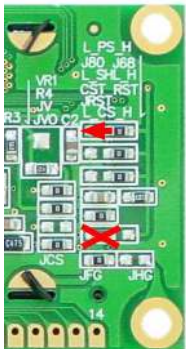

SPI

Pinout for SPI-Interface			
Pin	Symbol	Level	Description
1	VSS	L	Power Supply 0V, GND
2	VDD	H	Power Supply +3.3V~5V
3..11	NC	-	Not Connected
12	CLK	H / L	L-H: Serial Clock
13	MISO	H / L	Serial Data Output
14	MOSI	H / L	Serial Data Input
15	NC	-	Not Connected
16	CS	L	L: Chip Select

In delivery state the display can be connected directly to the 4- or 8-Bit data bus (compatible to 6800 mode). By changing the solder bridges, the mode „Z80“ is set. Additionally the SPI interface can be selected.

For timing information please refer to page 6 and 7.

OLED Character Displays

EA W202-XLG

FRAME
EA 017-7U

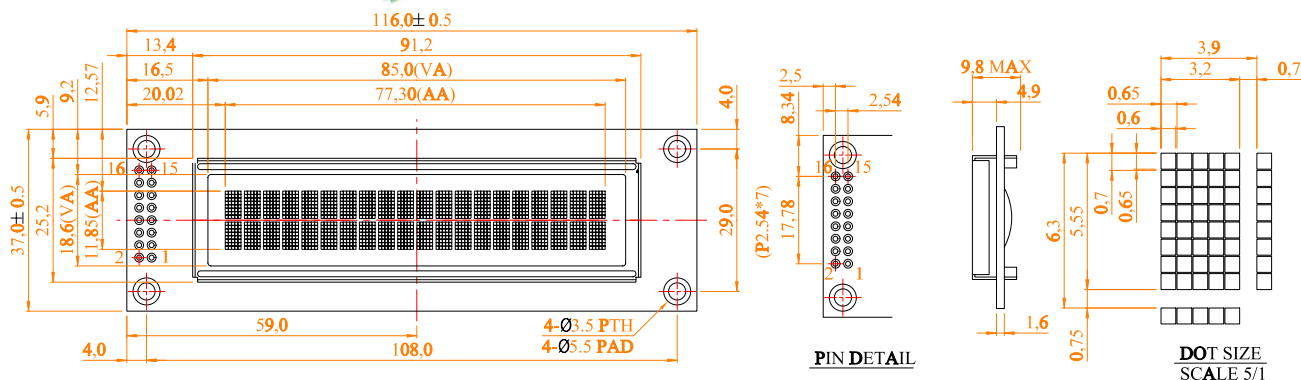

INTERFACE 4-/8-BIT, 6800/ Z80



4-/8-Bit 6800
(default)



4-/8-Bit Z80

SPI INTERFACE



SPI

In delivery state the display can be connected directly to the 4- or 8-Bit data bus (compatible to 6800 mode). By changing the solder bridges, the mode „Z80“ is set. Additionally the SPI interface can be selected.

For timing information please refer to page 6 and 7.

Pinout for 8-Bit Interface			
Pin	Symbol	Level	Description
1	VSS	L	Power Supply 0V, GND
2	VDD	H	Power Supply +3.3V-5V
3	NC	-	Not Connected
4	RS	H / L	Register Select
5	R/W (WR)	H / L (L)	H: Read / L: Write (L: Write, Z80-Mode)
6	E (RD)	H (L)	H: Enable (L: Read, Z80-Mode)
7..14	DO..D7	H / L	Data Bus, bidirectional
15	NC	-	Not Connected
16	NC	-	Not Connected

Pinout for 4-Bit Interface			
Pin	Symbol	Level	Description
1	VSS	L	Power Supply 0V, GND
2	VDD	H	Power Supply +3.3V-5V
3	NC	-	Not Connected
4	RS	H / L	Register Select
5	R/W (WR)	H / L (L)	H: Read / L: Write (L: Write, Z80-Mode)
6	E (RD)	H (L)	H: Enable (L: Read, Z80-Mode)
7..10	DNC	-	Do Not Connect
11..14	D4..D7	H / L	Data Bus, bidirectional
15	NC	-	Not Connected
16	NC	-	Not Connected

Pinout for SPI-Bit Interface			
Pin	Symbol	Level	Description
1	VSS	L	Power Supply 0V, GND
2	VDD	H	Power Supply +3.3V-5V
3..11	NC	-	Not Connected
12	CLK	H / L	L-H: Serial Clock
13	MISO	H / L	Serial Data Output
14	MOSI	H / L	Serial Data Input
15	NC	-	Not Connected
16	CS	L	L: Chip Select

OLED Character Displays

EA W204-XLG

FRAME
EA 017-9U

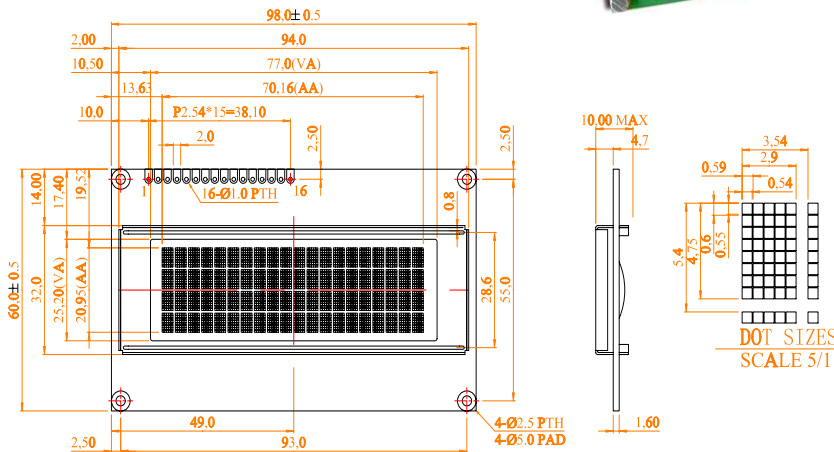

INTERFACE 4-/8-BIT, 6800/ Z80

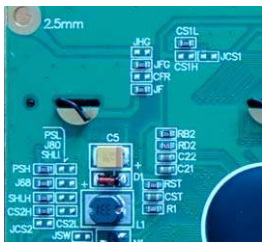

4-/8-Bit 6800
(default)

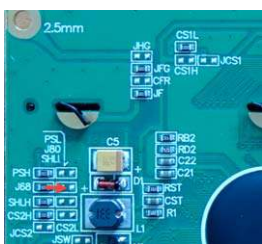

4-/8-Bit Z80

Pinout for 8-Bit Interface			
Pin	Symbol	Level	Description
1	VSS	L	Power Supply 0V, GND
2	VDD	H	Power Supply +3.3V-5V
3	NC	-	Not Connected
4	RS	H / L	Register Select
5	R/W (WR)	H / L (L)	H: Read / L: Write (L: Write, Z80-Mode)
6	E (RD)	H (L)	H: Enable (L: Read, Z80-Mode)
7..14	D0..D7	H / L	Data Bus, bidirectional
15	NC	-	Not Connected
16	NC	-	Not Connected

Pinout for 4-Bit Interface			
Pin	Symbol	Level	Description
1	VSS	L	Power Supply 0V, GND
2	VDD	H	Power Supply +3.3V-5V
3	NC	-	Not Connected
4	RS	H / L	Register Select
5	R/W (WR)	H / L (L)	H: Read / L: Write (L: Write, Z80-Mode)
6	E (RD)	H (L)	H: Enable (L: Read, Z80-Mode)
7..10	DNC	-	Do Not Connect
11..14	D4..D7	H / L	Data Bus, bidirectional
15	NC	-	Not Connected
16	NC	-	Not Connected

SPI INTERFACE

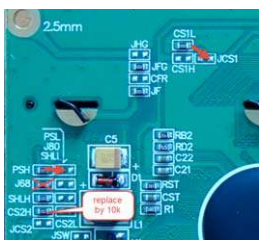

SPI

Pinout for SPI-Bit Interface			
Pin	Symbol	Level	Description
1	VSS	L	Power Supply 0V, GND
2	VDD	H	Power Supply +3.3V-5V
3..11	NC	-	Not Connected
12	CLK	H / L	L-H: Serial Clock
13	MISO	H / L	Serial Data Output
14	MOSI	H / L	Serial Data Input
15	CS	L	L: Chip Select
16	NC	-	Not Connected

In delivery state the display can be connected directly to the 4- or 8-Bit data bus (compatible to 6800 mode). By changing the solder bridges, the mode „Z80“ is set. Additionally the SPI interface can be selected. For timing information please refer to page 6 and 7.