

TPS22981 3.3-V to 18-V Thunderbolt™ Power Mux

1 Features

- Powered from 3.3 V
- 4.5-V to 19.8-V High-Voltage Switch
- 3-V to 3.6-V Switch
- Adjustable Current Limit
- Thermal Shutdown
- Make Before Break Switch
- High-Voltage Discharge Before Low-Voltage Make
- Reverse Current Blocking

2 Applications

- Notebook Computers
- Desktop Computers
- Power Management Systems

Typical Application

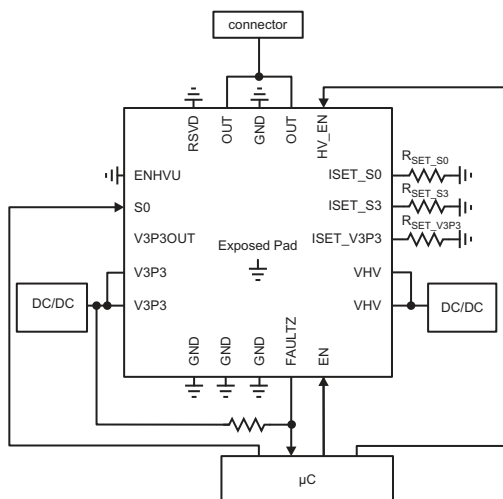

3 Description

The TPS22981 device is a current-limited power mux providing a connection to a peripheral device from either a low-voltage supply (3 V to 3.6 V) or a high-voltage supply (4.5 V to 19.8 V). The desired output is selected by digital control signals.

The high-voltage (VHV) and low-voltage (V3P3) switch current limits are set with external resistance. Once the current limit is reached, the TPS22981 will control the switch to maintain the current at this limit.

When the high-voltage supply is not present, the TPS22981 will maintain the connection to the output from the low-voltage supply. Upon the presence of a high-voltage line and high-voltage enable signal, the high-voltage switch is turned on in conjunction with the low-voltage switch until a reverse current is detected through the low-voltage switch, allowing a seamless transition from low voltage to the high-voltage supply with minimal droop and shoot-through current.

To prevent current backflow during a switch over from a VHV connection to a V3P3 connection, the TPS22981 will break the VHV connection, discharge the output to approximately 3.3 V and then make the V3P3 connection. The output may transition to 0 V when a load is present, before returning to 3.3 V.

The TPS22981 is available in a 4 mm × 4 mm × 1 mm VQFN package.

Device Information⁽¹⁾

PART NUMBER	PACKAGE	BODY SIZE (NOM)
TPS22981	VQFN (20)	4.00 mm × 4.00 mm

(1) For all available packages, see the orderable addendum at the end of the data sheet.



Table of Contents

1 Features	1	7.3 Feature Description	9
2 Applications	1	7.4 Device Functional Modes	13
3 Description	1	8 Application and Implementation	15
4 Revision History	2	8.1 Application Information	15
5 Pin Configuration and Functions	3	8.2 Typical Application	15
6 Specifications	4	9 Power Supply Recommendations	16
6.1 Absolute Maximum Ratings	4	10 Layout	17
6.2 ESD Ratings	4	10.1 Layout Guidelines	17
6.3 Recommended Operating Conditions	4	10.2 Layout Example	18
6.4 Thermal Information	5	11 Device and Documentation Support	19
6.5 Electrical Characteristics	5	11.1 Community Resources	19
6.6 Dissipation Ratings	6	11.2 Trademarks	19
7 Detailed Description	7	11.3 Electrostatic Discharge Caution	19
7.1 Overview	7	11.4 Glossary	19
7.2 Functional Block Diagram	8	12 Mechanical, Packaging, and Orderable Information	19

4 Revision History

NOTE: Page numbers for previous revisions may differ from page numbers in the current version.

Changes from Revision A (September 2013) to Revision B	Page
• Added <i>Pin Configuration and Functions</i> section, <i>ESD Ratings</i> table, <i>Feature Description</i> section, <i>Device Functional Modes</i> , <i>Application and Implementation</i> section, <i>Power Supply Recommendations</i> section, <i>Layout</i> section, <i>Device and Documentation Support</i> section, and <i>Mechanical, Packaging, and Orderable Information</i> section	1
• Replaced all the equations links needed to calculate resistor values in the table to the correct equation, Equation 1	3
• Changed V3P3OUT pinout 'capacitor' to 'capacitor to GND' throughout the data sheet	3
• Added labels to all pins in the Functional Block Diagram	8
• Changed <i>Input Inductive Bounce at Short Circuit</i> section title to Input Inductive Bounce	15
• Updated Figure 9 to show the EN pin as a device input	15

Changes from Original (December 2012) to Revision A	Page
• Removed <i>Ordering Information</i> table.	3
• Added R _{OUTDIS} parameter to the Electrical Characteristics table	5
• Updated UVLO ENABLE section	13

5 Pin Configuration and Functions

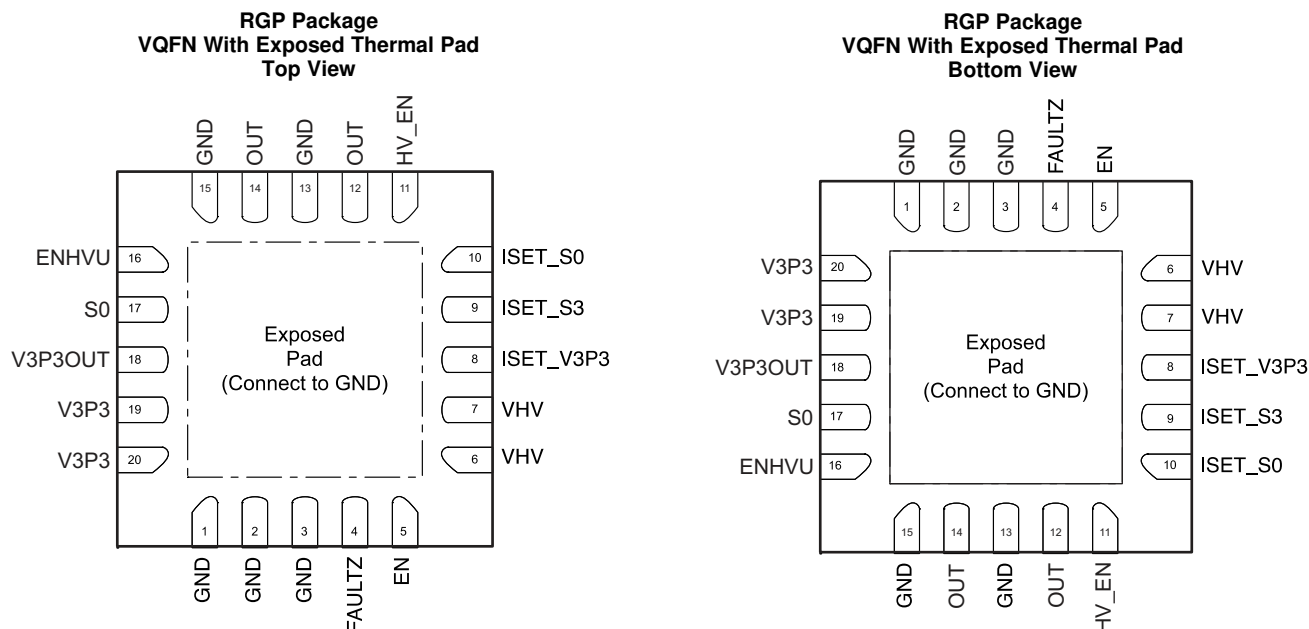

Pin Functions

PIN		TYPE	DESCRIPTION
NAME	NO.		
EN	5	I	Device active-high enable.
ENHVU	16	I	Enable VHV UVLO control of device enable. When asserted high, both V3P3 and VHV must be present for device enable. When low, only V3P3 must be present for device enable.
FAULTZ	4	O	Fault condition output. This pin is an open-drain pulldown indicating a fault condition. Place a pullup resistance (R_{FAULTZ}) between this pin and V3P3. Float pin or tie pin to GND if unused.
GND	1, 2, 3, 13, 15	P	Device ground. All GND pins must be connected to board ground.
GND	EP	P	Exposed pad must be connected to device GND.
HV_EN	11	I	Active-high voltage output enable.
ISET_S0	10	I	Sets the current limit for VHV in S0 mode. Place resistor between this pin and GND. See Equation 1 to calculate resistor value.
ISET_S3	9	I	Sets the current limit for VHV in S3 mode. Place resistor between this pin and GND. See Equation 1 to calculate resistor value.
ISET_V3P3	8	I	Sets the current limit for V3P3. Place resistor between this pin and GND. See Equation 1 to calculate resistor value.
OUT	12, 14	O	Power output. Place a minimum of 1- μ F capacitor to GND as close to this pin as possible.
S0	17	I	When this pin is asserted, the device is put in S0 mode. Otherwise the device operates in S3 mode.
V3P3	19, 20	P	3.3-V power supply input. Place a minimum of 0.1- μ F capacitor to GND as close to this pin as possible.
V3P3OUT	18	O	3.3-V bypass output. When ENHVU is low, this path is enabled by EN and the V3P3 UVLO. When ENHVU is high, this path is enabled by EN and both the V3P3 UVLO and the VHV UVLO. Place a minimum 0.1- μ F capacitor to GND as close to this pin as possible.
VHV	6, 7	P	High voltage power supply input. See the Input Inductive Bounce section for more information.

6 Specifications

6.1 Absolute Maximum Ratings

over operating free-air temperature range (unless otherwise noted)⁽¹⁾

		MIN	MAX	UNIT
V _I	Input voltage on V3P3 (VDD) ⁽²⁾	-0.3	3.6	V
	Input voltage on EN, HV_EN, ENHVU, ISET_V3P3, ISET_S0, ISET_S3, S0 ⁽²⁾	-0.3	V3P3 + 0.3	
	Output voltage on FAULTZ	-0.3	V3P3 + 0.3	
	Input voltage on VHV ⁽²⁾	-0.3	20	
	Output voltage at OUT ⁽²⁾	-0.3	20	
	Voltage between VHV and OUT (V _{VHV} – V _{OUT})	-7	20	
	Output voltage at V3P3OUT ⁽²⁾	-0.3	V3P3 + 0.3	
T _A	Operating ambient temperature ⁽³⁾	-40	85	°C
T _{J (MAX)}	Maximum operating junction temperature		110	°C
T _{stg}	Storage temperature	-65	150	°C

- (1) Stresses beyond those listed under *Absolute Maximum Ratings* may cause permanent damage to the device. These are stress ratings only, which do not imply functional operation of the device at these or any other conditions beyond those indicated under *Recommended Operating Conditions*. Exposure to absolute-maximum-rated conditions for extended periods may affect device reliability.
- (2) All voltage values are with respect to network ground terminal.
- (3) In applications where high-power dissipation and/or poor package thermal resistance is present, the maximum ambient temperature may have to be derated. Maximum ambient temperature [T_{A(max)}] is dependent on the maximum operating junction temperature [T_{J(max)}], the maximum power dissipation of the device in the application [PD(max)], and the junction-to-ambient thermal resistance of the part/package in the application (θ_{JA}), as given by the following equation: T_{A(max)} = T_{J(max)} – (θ_{JA} × PD(max))

6.2 ESD Ratings

		VALUE	UNIT
V _(ESD)	Electrostatic discharge	Human body model (HBM), per ANSI/ESDA/JEDEC JS-001 ⁽¹⁾	±2000
		Charged-device model (CDM), per JEDEC specification JESD22-C101 ⁽²⁾	±500

- (1) JEDEC document JEP155 states that 500-V HBM allows safe manufacturing with a standard ESD control process.
- (2) JEDEC document JEP157 states that 250-V CDM allows safe manufacturing with a standard ESD control process.

6.3 Recommended Operating Conditions

over operating free-air temperature range (unless otherwise noted)

		MIN	MAX	UNIT	
V _{3P3}	Supply voltage	3	3.6	V	
V _{HV}		4.5	19.8	V	
I _{LIM3P3OUT}	V3P3OUT switch current	0	500	mA	
V _{IH}	Input logic high	EN, HV_EN, ENHVU, S0	V3P3 – 0.6	V3P3	V
V _{IL}	Input logic low	EN, HV_EN, ENHVU, S0	0	0.6	V
R _{SET_V3P3}	3.3-V switch current limit set resistance	26.7	402	kΩ	
R _{SET_S0}	VHV switch current limit in S0 mode set resistance	26.7	402	kΩ	
R _{SET_S3}	VHV switch current limit in S3 mode set resistance	26.7	402	kΩ	
R _{FAULTZ}	FAULTZ pullup resistance to V3P3	30		kΩ	

6.4 Thermal Information

THERMAL METRIC ⁽¹⁾		TPS22981	
		RGP (VQFN)	
		20 PINS	
R _{θJA}	Junction-to-ambient thermal resistance	39.3	°C/W

(1) For more information about traditional and new thermal metrics, see the *Semiconductor and IC Package Thermal Metrics* application report, [SPRA953](#).

6.5 Electrical Characteristics

Unless otherwise noted the specification applies over the V_{DD} range and operating junction temp $-40^{\circ}\text{C} \leq T_J \leq 85^{\circ}\text{C}$. Typical values are for V_{3P3} = 3.3 V, V_{HV} = 15 V, and T_J = 25°C.

PARAMETER		TEST CONDITIONS	MIN	TYP	MAX	UNIT
POWER SUPPLIES AND CURRENTS						
V _{3P3}	V3P3 input voltage range		3	3.3	3.6	V
V _{HV}	VHV input voltage range		4.5		19.8	V
I _{VHVACT}	Active quiescent current from VHV	HV_EN = 1, EN = 1			150	μA
I _{VHVSD}	Shutdown leakage current from VHV	HV_EN = 0, EN = 0 or 1			60	μA
I _{DDACT}	Active quiescent current from V3P3	EN = 1, HV_EN = 0			500	μA
I _{DDACTHV}		EN = 1, HV_EN = 1			500	μA
I _{DDSD}	Shutdown quiescent current from V3P3	EN = 0, OUT = 0 V			30	μA
I _{DIS}	OUT discharge current	EN = 1, V _{HV} = 5V, HV_EN = 1→0	5		10	mA
I _{IN}	HV_EN, EN, ENHVU, S0, S3 input pin leakage	V = 0 V			1	μA
		V = V3P3			1	
SWITCH AND RESISTANCE CHARACTERISTICS						
R _{SHV}	VHV switch resistance	V _{HV} = 5V to 18V, I _{VHV} = 0.9A			250	mΩ
R _{S3P3}	V3P3 switch resistance	V _{3P3} = 3.3 V, I _{V3P3} = 0.9 A			125	mΩ
R _{S3P3BYP}	V3P3 bypass switch resistance	V _{3P3} = 3.3 V, I _{V3P3} = 500 mA			500	mΩ
R _{OUTDIS}	OUT pulldown resistance when disabled	EN = 0	1.5	2.5	4	kΩ
V _{OLFAULTZ}	FAULTZ VOL	I _{FAULTZ} = 250 μA			0.6	V
VOLTAGE THRESHOLDS						
V _{HVUVLO}	VHV undervoltage lockout	VHV Input falling	3.6	4		V
		VHV Input rising		4	4.3	
V _{3P3UVLO}	V3P3 undervoltage lockout	V3P3 Input falling	1.8	2.25		V
		V3P3 Input rising		2.25	2.5	
V _{FAULTZVAL}	V3P3 voltage for valid FAULTZ	EN = 1	1.8			V
THERMAL SHUTDOWN						
T _{SD}	Shutdown temperature		110	120	130	°C
T _{SDHYST}	Shutdown hysteresis			10		°C
CURRENT LIMIT						
I _{LIMHV}	VHV switch current limit state S0 or S3	R _{SET_S0,3} = 402 kΩ ⁽¹⁾	80	100	120	mA
		R _{SET_S0,3} = 80.6 kΩ ⁽¹⁾	446	496	546	
		R _{SET_S0,3} = 26.7 kΩ ⁽¹⁾	1423	1498	1573	
I _{LIMVHVMAX}	Maximum VHV switch current limit	R _{SET_S0,3} = 0 Ω	1.8	2.4	3.1	A
I _{LIM3P3}	V3P3 switch current limit	R _{SET_V3P3} = 402 kΩ ⁽¹⁾	80	100	120	mA
		R _{SET_V3P3} = 80.6 kΩ ⁽¹⁾	446	496	546	
		R _{SET_V3P3} = 26.7 kΩ ⁽¹⁾	1423	1498	1573	
I _{LIM3P3MAX}	Maximum V3P3 switch current limit	R _{SET_V3P3} = 0 Ω	1.8	2.4	3.1	A
I _{REV3P3}	V3P3 switch reverse current limit		10	40	85	mA
T _{V3P3RC}	V3P3 switch reverse current response time	V _{OUT} = V _{3P3} → V _{3P3} + 20 mV			100	μs
T _{VHVSC}	VHV switch short circuit response time	C _{OUT} ≤ 20 pF		8		μs
T _{V3P3SC}	V3P3 switch short circuit response time	C _{OUT} ≤ 20 pF		8		μs

(1) [Equation 1](#) is used to calculate the required resistance for a given minimum I_{LIM}. The nearest 1% resistance is chosen and the corresponding I_{LIM} variance is shown.

Electrical Characteristics (continued)

Unless otherwise noted the specification applies over the V_{DD} range and operating junction temp $-40^{\circ}\text{C} \leq T_J \leq 85^{\circ}\text{C}$. Typical values are for $V_{3P3} = 3.3\text{ V}$, $V_{HV} = 15\text{ V}$, and $T_J = 25^{\circ}\text{C}$.

PARAMETER		TEST CONDITIONS	MIN	TYP	MAX	UNIT
TRANSITION DELAYS						
T_{3P3OFF}	VHV to V3P3 OFF-time	$C_{OUT} = 1.1\ \mu\text{F}$, EN = 1, HV_EN = 1→0			6	ms
$T_{0-3.3V}$	0-V to 3.3-V ramp time	$C_{OUT} \leq 20\ \text{pF}$			6	ms
$T_{3.3V-VHV}$	3.3-V to VHV ramp time	$C_{OUT} \leq 20\ \text{pF}$			6	ms
$T_{VHV-3.3V}$	VHV to 3.3-V ramp time	$C_{OUT} \leq 20\ \text{pF}$			23	ms
T_{LIM}	Overcurrent response time	$C_{OUT} \leq 20\ \text{pF}$, $I_{OUT} = 6\ \text{A}$			0.5	ms

6.6 Dissipation Ratings

PACKAGE	POWER RATING ⁽¹⁾ $T_A = 25^{\circ}\text{C}$	POWER RATING ⁽¹⁾ $T_A = 70^{\circ}\text{C}$	DERATING FACTOR ABOVE ⁽²⁾ $T_A = 25^{\circ}\text{C}$
RGP	2.16 W	1.02 W	25.4 mW/°C

(1) Simulated with high-K board

(2) Maximum power dissipation is a function of $T_{J(max)}$, θ_{JA} and T_A . The maximum allowable power dissipation at any allowable ambient temperature is $P_D = (T_{J(max)} - T_A) / \theta_{JA}$.

7 Detailed Description

7.1 Overview

TPS22981 is a power mux designed for Thunderbolt™ and Thunderbolt II™ applications (based on the Mini DisplayPort connector). Thunderbolt and Thunderbolt II provide options for different voltage levels to be supplied to an external Thunderbolt cable, and on to a device or host connected on the far end of that cable. Thunderbolt and Thunderbolt II initiate operation with a nominal 3.3-V voltage (3-V to 3.6-V range is supported by TPS22981), but can be configured through the interface protocol to enable a high-voltage mode (TPS22981 supports the range of 4.5 V to 19.8 V). In operation, transition from the 3.3-V mode to the high-voltage mode requires that system brownout not occur. The TPS22981 achieves this by enabling the high-voltage path (when a high-voltage input is available and HV_EN is asserted) and monitoring for reverse current through the low-voltage switch back to V3P3. When reverse current is detected, the low-voltage path is disabled. Similarly, when switching from high voltage back to low voltage, it is normally undesirable for the system output voltage to brownout. TPS22981 avoids brownout by breaking the high-voltage connection and discharging the output until it reaches approximately 3.3 V, at which point the low-voltage path is enabled to avoid excessive droop of the output voltage. However, if the output voltage (on the OUT pins) is loaded, the output voltage may transition to 0 V before returning to 3.3 V (see [Transition Delays](#)).

TPS22981 also provides resistor-controlled current limiting, undervoltage lockout (UVLO), and thermal protection. The high-voltage path on TPS22981 may be current limited to two independently controlled current-limiting levels, with the current-limiting level selected through the S0 input pin. A system host processor may be alerted to fault conditions with the FAULTZ pin (see [Table 3](#)).

7.2 Functional Block Diagram

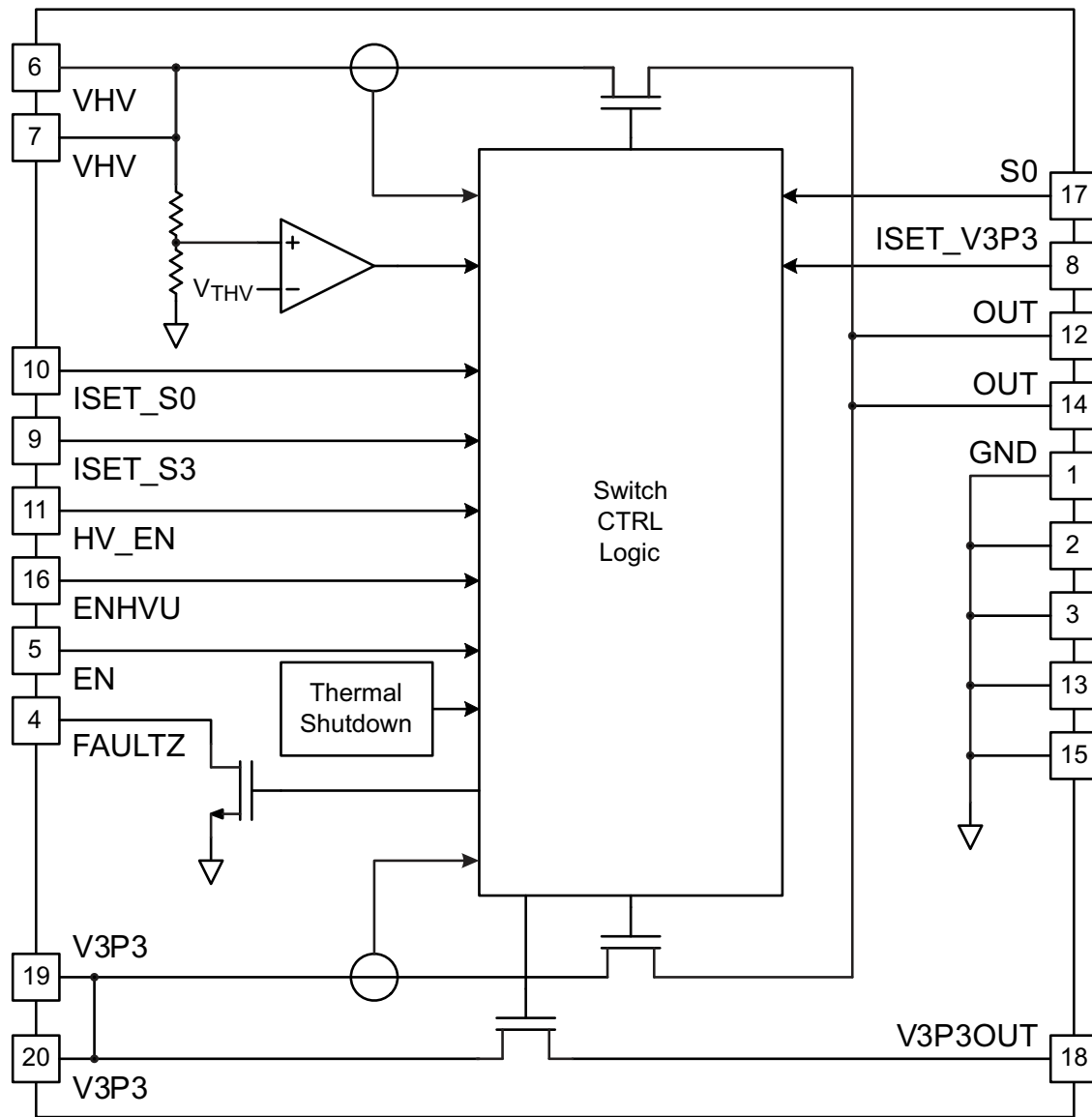

7.3 Feature Description

7.3.1 Current Limit

Figure 1 shows a simplified view of the TPS22981 current limit function. Both the high-voltage supply current limit and the V3P3 supply current limit are adjustable by external resistors.

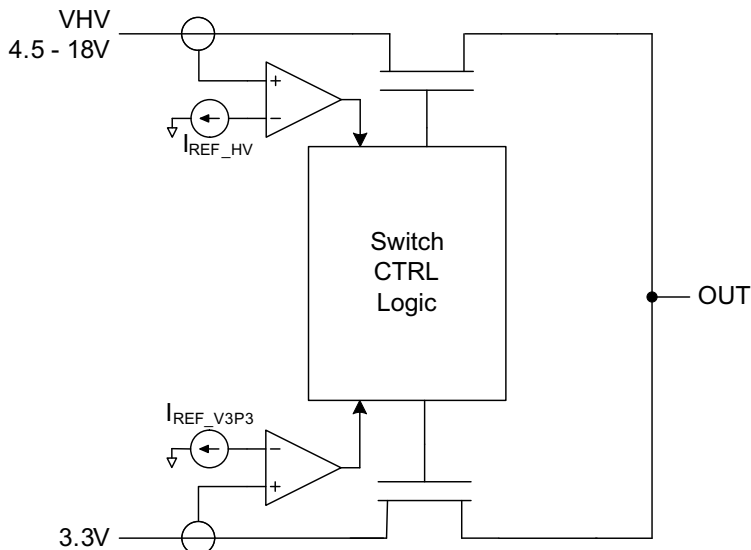

Figure 1. Simplified Current Limit Diagram

The current I_{REF_HV} and I_{REF_V3P3} that set the current limit threshold are set with three external resistors as shown in Figure 2. When the TPS22981 is passing the V3P3 voltage, the current limit is set by R_{SET_V3P3} . The VHV path has two modes that allow setting two different current limits. The S0 pin determines which current limit is used. When S0 is asserted high, R_{SET_S0} sets the current limit. When S0 is low, R_{SET_S3} sets the current limit. This allows the system to have two separate VHV current limits for different modes such as active and sleep.

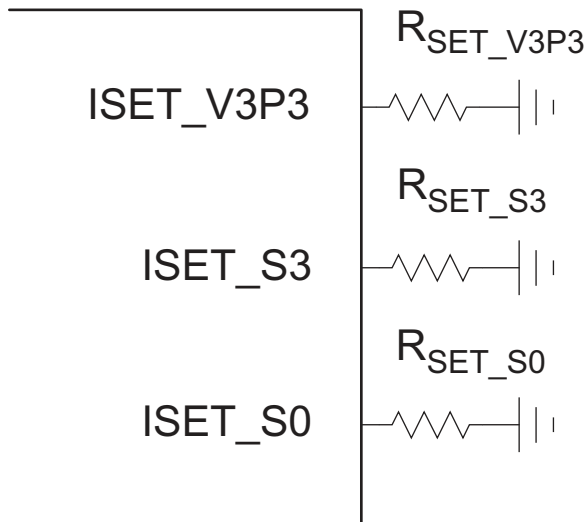

Figure 2. External R_{SET} Resistance to Set Current Limits

Feature Description (continued)

7.3.2 Current Limit Threshold

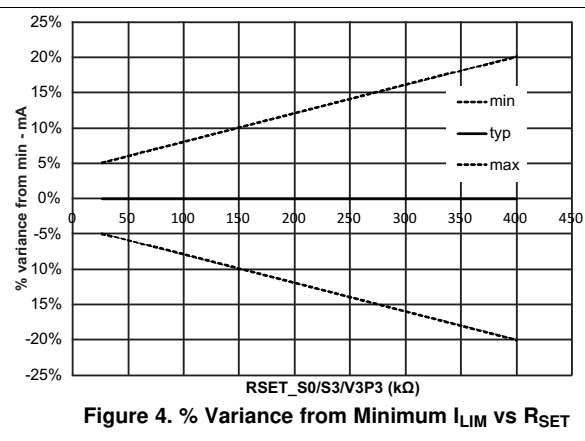
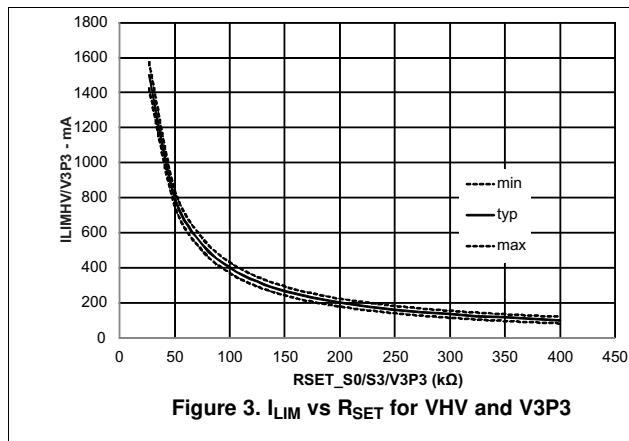

Figure 3 shows the minimum, typical, and maximum current limit for either supply versus its corresponding R_{SET} value. Equation 1 is used to determine the R_{SET} needed to set a typical I_{LIM} for a given supply and mode. Figure 4 shows the percent variation from the typical I_{LIM} value to the minimum and maximum I_{LIM} values.

$$R_{SET} = \frac{40 \text{ k}\Omega \times \text{Amps}}{I_{LIMTYP}}$$

where

- R_{SET} = external resistor used to set the current limit for V3P3, VHV (S0), or VHV (S3)
- I_{LIMTYP} = typical current limit for V3P3, VHV (S0), or VHV (S3) set by the external R_{SET} resistor. (1)

Each resistor is placed between the corresponding ISET pin and GND, as shown in Figure 2, providing a minimum current limit between 100mA and 1.5A. For a given R_{SET} the minimum current limit and the maximum current limit are determined by Equation 2 and Equation 3.

$$I_{LIMMIN} = \frac{38429}{R_{SET}} - 0.0161 \text{ A} \quad (2)$$

$$I_{LIMMAX} = \frac{41571}{R_{SET}} + 0.0161 \text{ A} \quad (3)$$

7.3.3 Maximum Current Limit Threshold

The TPS22981 has a maximum current limit $I_{LIMVHVMAX}$ and $I_{LIM3P3MAX}$. This prevents excessive current in the case of an ISET pin being shorted to ground.

7.3.4 Transition Delays

Output transitions of the TPS22981 voltages are shown in Figure 5. When the device transitions from V_{HV} to V_{3P3} at the output, the power switches both turn off until the output falls to near the V_{3P3} voltage. During this time, a discharge current of I_{DIS} pulls OUT down. If a load is also pulling current from OUT, the output will drop to near 0 V due to the switch OFF-time of T_{3P3OFF} .

Feature Description (continued)

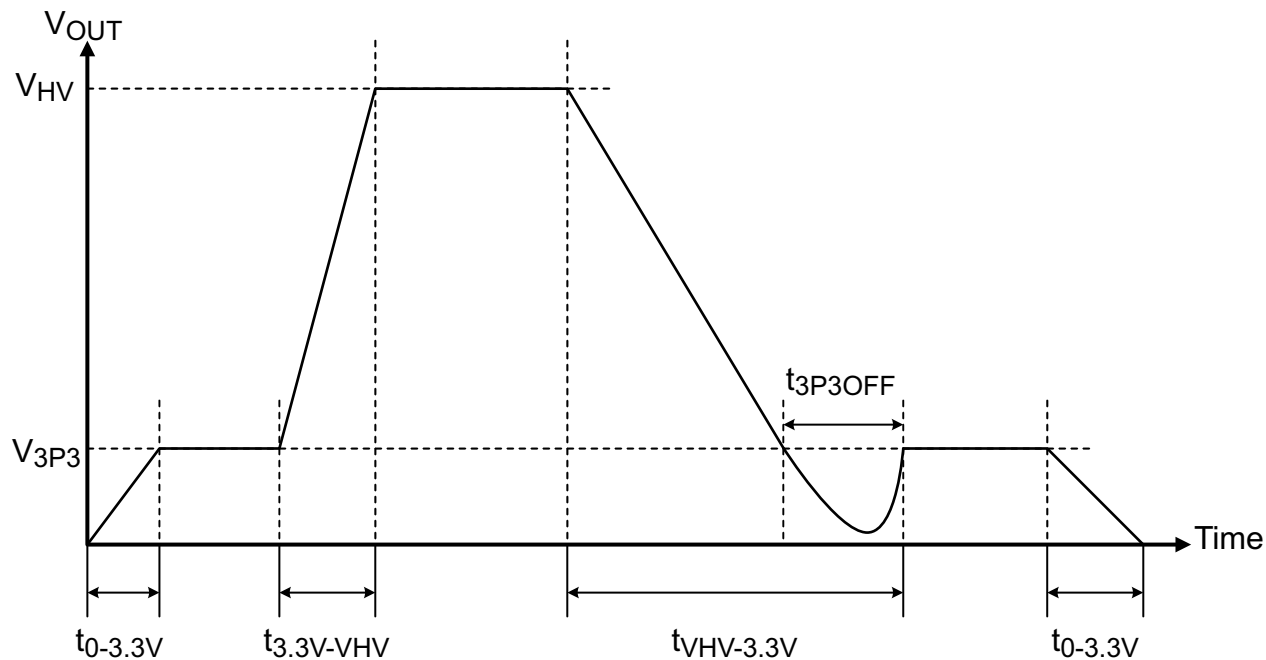

Figure 5. Output Voltage Transitions (Timing Transitions are 10% to > 90%)

7.3.5 Digital Control Signals

The voltage at OUT is controlled by two input digital logic signals, EN and HV_EN. HV_EN controls the state of the VHV switch and EN controls the state of V3P3 switch. [Table 1](#) lists the possible output states given the conditions of the digital logic signals and the device is not in UVLO. See [Table 2](#) for a more complete description including both UVLO conditions.

Table 1. Output State of OUT Given the States EN and HV_EN

EN	HV_EN	OUT
0	0	OPEN
0	1	OPEN
1	0	V3P3
1	1	VHV

Figure 6 shows possible combinations of EN and HV_EN controlling OUT of the TPS22981.

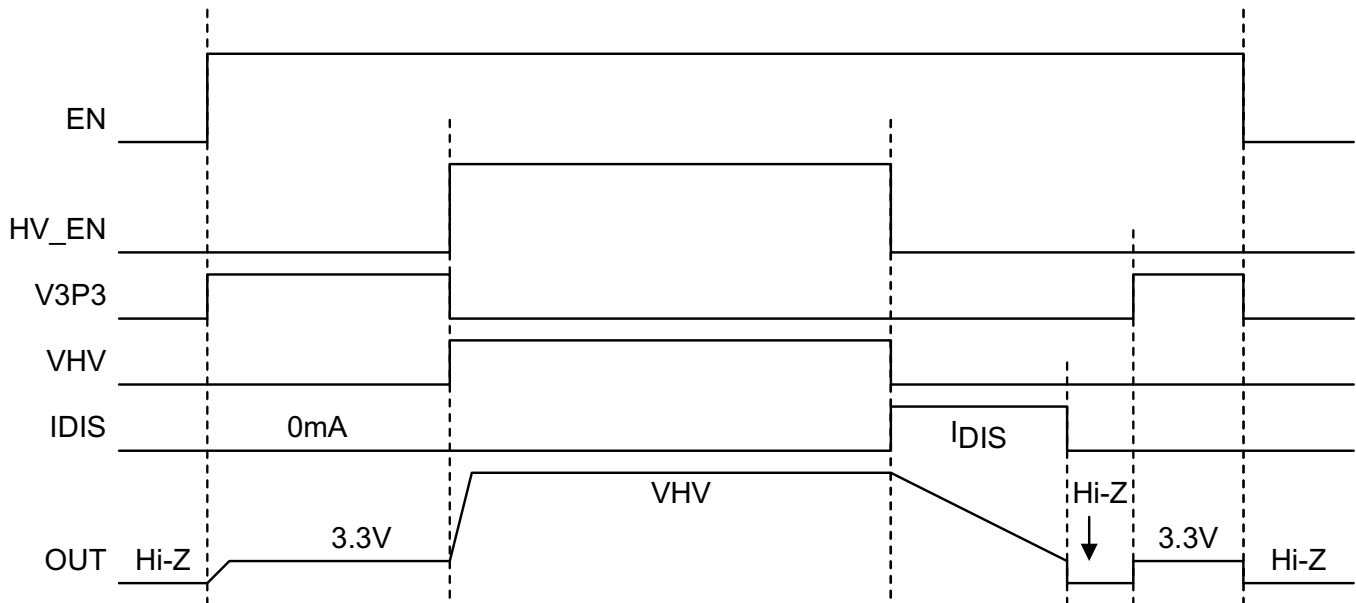

Figure 6. Logic Waveforms Displaying the Transition Between VHV and V3P3

7.3.6 Overcurrent Limit and Short-Circuit Protection

When the load at OUT attempts to draw more current than the limit set by the external R_{SET} resistors for the V3P3 switch and VHV switch (for both S0 and S3 modes), the device will operate in a constant-current mode while lowering the output voltage. Figure 7 shows the delay, t_{LIM} , which occurs from the instance an overcurrent fault is detected until the output current is lowered to I_{LIMHV} tolerances for VHV or I_{LIM3V3} tolerances for V3P3 shown in Figure 3. Figure 8 shows the response time versus a resistance shorted across the output.

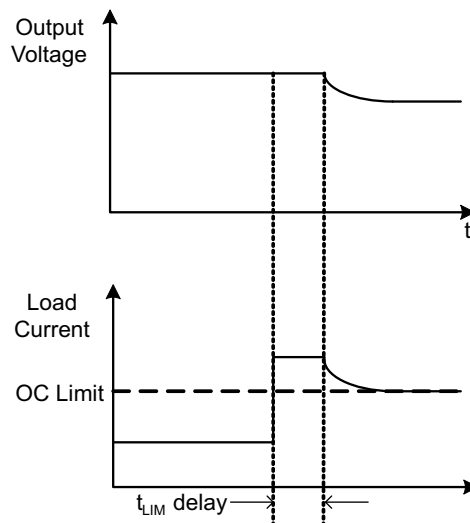

Figure 7. Overcurrent Output Response



Figure 8. Overcurrent Response Time vs Short Resistance

All short-circuit conditions are treated as overcurrent conditions. In the event of a short circuit, the device will limit the output current to the corresponding R_{SET} value and continue to do so until thermal shutdown is encountered or the short-circuit condition is removed.

7.3.7 Reverse Current Protection

Reverse current protection for the V3P3 supply to OUT triggers at I_{REV3P3} causing the V3P3 supply switch to open. When the HV_EN signal is not asserted and reverse current protection is triggered, a discharge current source is turned on to bring the output voltage to near the V3P3 voltage.

7.3.8 Reverse Current Blocking

The VHV switch blocks reverse current flow from OUT to VHV when the switch is off.

7.3.9 Thermal Shutdown

The device enters thermal shutdown when junction temperature reaches T_{SD} . The device will resume previous state on power up once the junction temperature has dropped by 10°C. Connect thermal vias to the exposed GND pad underneath the device package for improved thermal diffusion.

7.4 Device Functional Modes

7.4.1 UVLO and Enable

When ENHVU is low, the TPS22981 is enabled by the logical AND of the EN input, the V3P3 UVLO, and the Thermal Shutdown. When the V3P3 UVLO threshold has been crossed, the device is not in thermal shutdown, and the EN input is high, the device will enable. When the V3P3 UVLO triggers, regardless of the states of any digital logic controls, the device will open all switches.

ENHVU adds the VHV UVLO to the logical decision enabling the device. When ENHVU is high, the TPS22981 is enabled by the logical AND of the EN input, the V3P3 UVLO, the VHV UVLO, and the thermal shutdown. When both UVLO thresholds have been crossed, the device is not in thermal shutdown, and the EN input is high, the device will enable. When either UVLO triggers, regardless of the states of any digital logic controls, the device will open all switches. Table 2 shows the pin and voltage configurations for enabling the device.

NOTE

A 1 for the UVLO columns means the device is in a UVLO condition. A PD indicates a pulldown resistance of R_{OUTDIS} to GND.

Table 2. Device Enable Control (When in an Undervoltage Condition, UVLO = 1)

EN	ENHVU	HV_EN	V3P3 UVLO	VHV UVLO	OUT
0	X	X	X	X	PD
1	X	X	1	X	PD
1	1	X	0	X	OPEN
1	1	X	1	X	PD
1	0	0	0	X	V3P3
1	1	0	0	0	V3P3
1	X	1	0	0	VHV
1	0	1	0	1	V3P3

7.4.2 FAULTZ Output

The TPS22981 has an open-drain FAULTZ output. When the device is in a fault condition, the FAULTZ output will pull low. Connect FAULTZ through a pullup resistance to V3P3. A Fault occurs during any of the following conditions.

- EN = 1 and V3P3 is in UVLO (device enabled and V3P3 is in an undervoltage condition)
- EN = 1 and in thermal shutdown condition
- EN = 1, HV_EN = 1, and VHV is in UVLO (device enabled, high voltage enabled, and VHV is in an undervoltage condition)

Table 3 shows these conditions and the resulting FAULTZ output. Note, when V3P3 is below the UVLO threshold, FAULTZ will be 0 when EN=1 or 1 when EN=0. However, when V3P3 falls below $V_{FAULTZVAL}$, the FAULTZ output is unknown.

Table 3. FAULTZ Output Conditions (when in an undervoltage condition, UVLO = 1)

EN	HV_EN	Thermal Shutdown	V3P3 UVLO	VHV UVLO	FAULTZ (Active Low)
0	X	X	X	X	1
1	X	X	1	X	0
1	X	Yes	0	X	0
1	0	No	0	1	1
1	1	No	0	1	0
1	X	No	0	0	1

TI recommends that the pullup resistance on FAULTZ be 100 kΩ and must be greater than or equal to 30 kΩ.

8 Application and Implementation

NOTE

Information in the following applications sections is not part of the TI component specification, and TI does not warrant its accuracy or completeness. TI's customers are responsible for determining suitability of components for their purposes. Customers should validate and test their design implementation to confirm system functionality.

8.1 Application Information

8.1.1 Input Inductive Bounce

When a significant inductance is seen at the VHV input, suddenly turning off large current through the device may produce a large enough inductive voltage bounce on the VHV pin to exceed the maximum safe operating condition and damage the TPS22981. To prevent this, reduce any inductance at the VHV input.

8.2 Typical Application

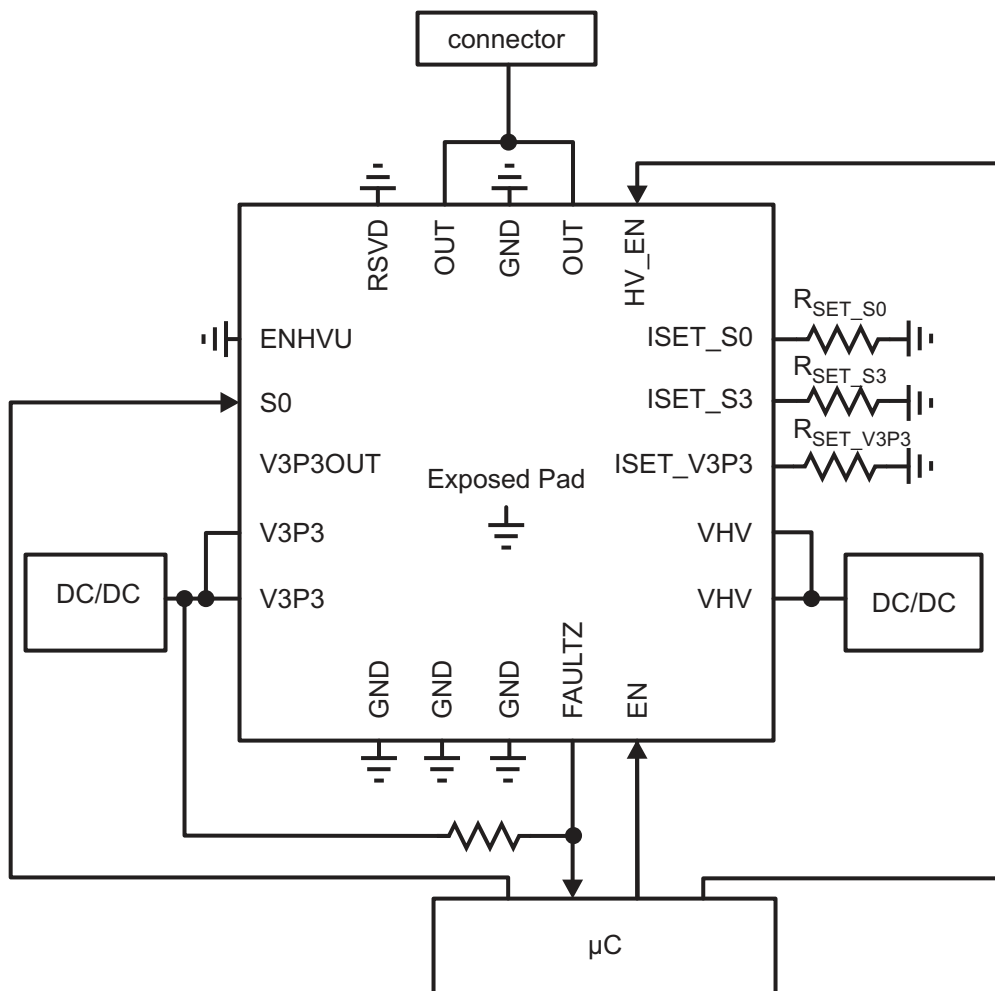

Figure 9. Typical Application Schematic

Typical Application (continued)

8.2.1 Design Requirements

As the TPS22981 switches high-current levels, it is essential that all parallel output, power, and ground pins be connected. For example, ground connections must be provided on all ground pins including pins 1, 2, 3, 13, 15, and EP (the exposed package pad); both OUT pins (pins 12 and 14) must be connected; and so forth. RSET_S0, RSET_S3, and RSET_V3P3 must be determined using [Equation 1](#). Unused inputs may not be left floating and should be connected to either ground or V3P3 depending on desired behavior.

8.2.2 Detailed Design Procedure

Design with TPS22981 is recommended as follows:

- Determine suitable current limits for the low-voltage and high-voltage output levels (output provided on the OUT pin). If S0 is being used, determine both high-voltage output levels and current-limiting values.
- Determine values for the resistors to be applied to pins ISET_V3P3, ISET_S3, and ISET_S0 using [Equation 1](#) and the desired current limits determined above.
- If the FAULTZ output is being used, place a minimum 30-k Ω resistor (100-k Ω recommended) between FAULTZ and the V3P3.

9 Power Supply Recommendations

Power supply current capability should be suitable with respect to the maximum current limit levels selected (and programmed with pins ISET_V3P3, ISET_S3, and ISET_S0).

VHV and V3P3 must be properly decoupled. A minimum 0.1- μ F capacitor to ground is recommended as close to the V3P3 pin as possible. VHV should be suitably decoupled based on the supply compliance and maximum current levels anticipated. Inductance in the VHV line can result in overvoltage situations on the VHV pin when loads are disconnected. Refer to the [Input Inductive Bounce](#) section and ensure that inductance levels, capacitive decoupling, and current switching levels are designed to keep power supply voltage levels within recommended operating conditions at all times.

10 Layout

10.1 Layout Guidelines

- Ensure decoupling capacitors on the OUT, V3P3, and V3P3OUT pins are tied directly to a solid ground plane or ground connection, and are placed as close to each respective pin as possible.
- Route the VHV input to minimize total inductance between the source for this power supply and the VHV pin. See [Input Inductive Bounce](#) regarding inductance in the VHV input potentially causing damaging voltage levels if large currents are suddenly turned off in the course of system operation.
- Layout trace width should be checked to ensure adequate current carrying ability and suitable resistive voltage drops in view of peak current levels.

Figure 10 shows the schematic used for the layout provided in the [Layout Example](#) section.

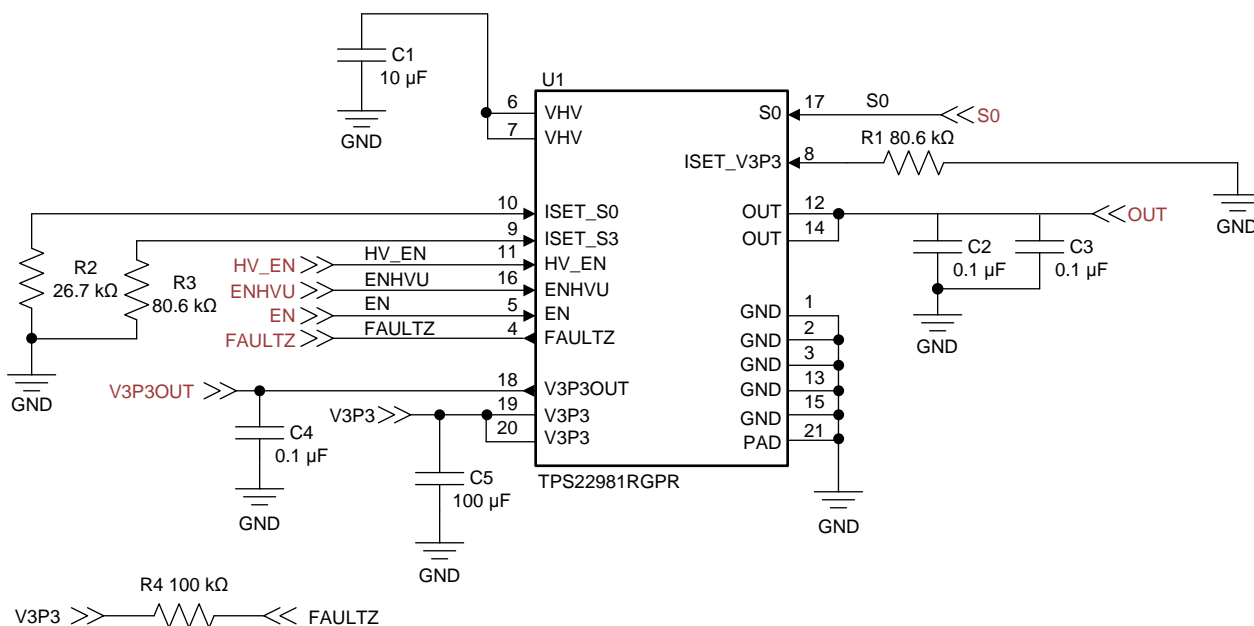

Figure 10. Layout Example Schematic

The TPS22981 can be placed on the same layer as its components. The layout can be a smaller area when the bottom is used for component placement. In this design example, the components and the TPS22981 are placed on the top layer. [Figure 11](#) and [Figure 12](#) show the suggested placement of the components.

For the nets V3P3, OUT, and VHV, TI recommends to use Thunderbolt three 8-mil or 16-mil vias when moving from layer to layer. A 40-mil trace or pour will allow roughly 2 A to pass current carrying capability with 0.5-oz. copper. Two 8-mil or 16-mil vias and 12-mil traces are sufficient for V3P3OUT. All of the other signals can be routed using a 10-mil trace with an 8-mil or 16-mil via. [Figure 13](#) and [Figure 14](#) show the suggested power and signal routing with and without a GND pour on the top layer. TI recommends that the capacitors and the GND pad on the TPS22981 are connected on the same plane.

The remaining signals can be routed through the bottom layer or other internal layer. [Figure 15](#) shows the bottom routing.

10.2 Layout Example

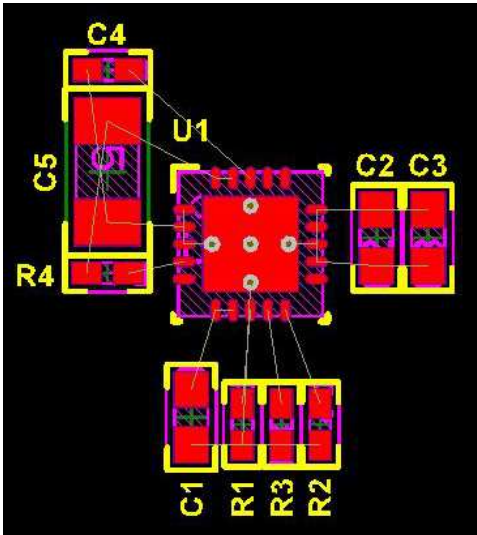

Figure 11. Top Layer 2D View

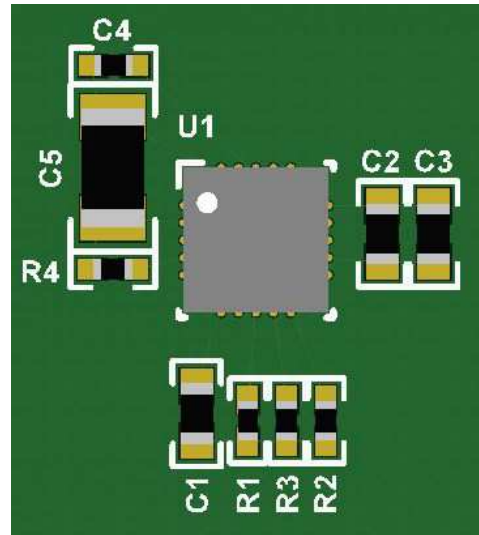

Figure 12. Top Layer 3D View

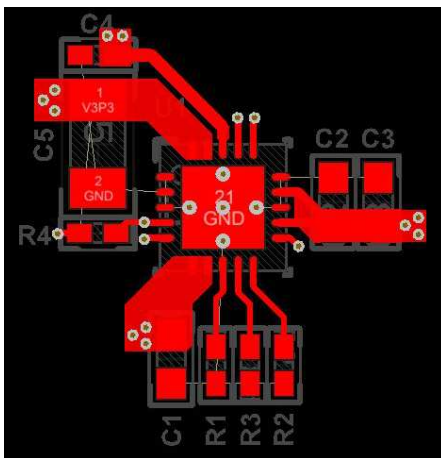

Figure 13. Power/Signal Routing Without GND Pour

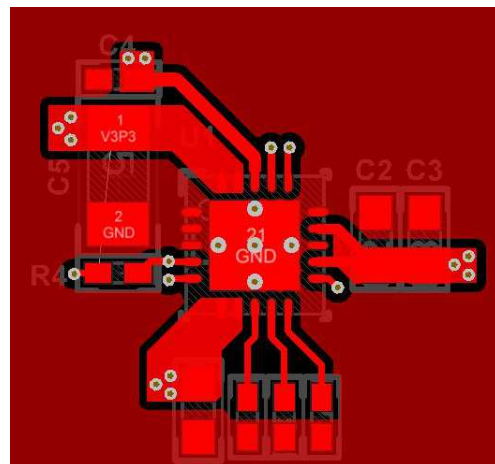

Figure 14. Power/Signal Routing With GND Pour

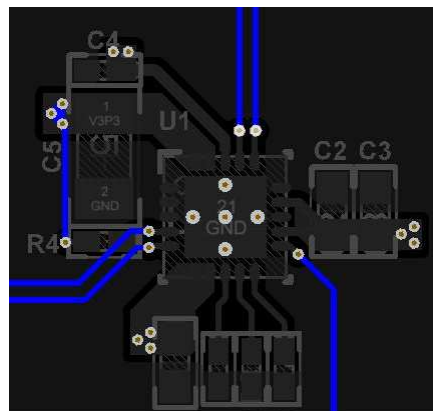

Figure 15. Bottom Layer Routing

11 Device and Documentation Support

11.1 Community Resources

The following links connect to TI community resources. Linked contents are provided "AS IS" by the respective contributors. They do not constitute TI specifications and do not necessarily reflect TI's views; see TI's [Terms of Use](#).

TI E2E™ Online Community *TI's Engineer-to-Engineer (E2E) Community*. Created to foster collaboration among engineers. At e2e.ti.com, you can ask questions, share knowledge, explore ideas and help solve problems with fellow engineers.

Design Support *TI's Design Support* Quickly find helpful E2E forums along with design support tools and contact information for technical support.

11.2 Trademarks

E2E is a trademark of Texas Instruments.
Thunderbolt, Thunderbolt II are trademarks of Intel Corporation.
All other trademarks are the property of their respective owners.

11.3 Electrostatic Discharge Caution



These devices have limited built-in ESD protection. The leads should be shorted together or the device placed in conductive foam during storage or handling to prevent electrostatic damage to the MOS gates.

11.4 Glossary

[SLYZ022](#) — *TI Glossary*.

This glossary lists and explains terms, acronyms, and definitions.

12 Mechanical, Packaging, and Orderable Information

The following pages include mechanical, packaging, and orderable information. This information is the most current data available for the designated devices. This data is subject to change without notice and revision of this document. For browser-based versions of this data sheet, refer to the left-hand navigation.

PACKAGING INFORMATION

Orderable Device	Status (1)	Package Type	Package Drawing	Pins	Package Qty	Eco Plan (2)	Lead finish/ Ball material (6)	MSL Peak Temp (3)	Op Temp (°C)	Device Marking (4/5)	Samples
TPS22981RGPR	ACTIVE	QFN	RGP	20	3000	RoHS & Green	NIPDAU	Level-2-260C-1 YEAR	-40 to 85	PS22981	Samples
TPS22981RGPT	ACTIVE	QFN	RGP	20	250	RoHS & Green	NIPDAU	Level-2-260C-1 YEAR	-40 to 85	PS22981	Samples

(1) The marketing status values are defined as follows:

ACTIVE: Product device recommended for new designs.

LIFEBUY: TI has announced that the device will be discontinued, and a lifetime-buy period is in effect.

NRND: Not recommended for new designs. Device is in production to support existing customers, but TI does not recommend using this part in a new design.

PREVIEW: Device has been announced but is not in production. Samples may or may not be available.

OBSOLETE: TI has discontinued the production of the device.

(2) **RoHS:** TI defines "RoHS" to mean semiconductor products that are compliant with the current EU RoHS requirements for all 10 RoHS substances, including the requirement that RoHS substance do not exceed 0.1% by weight in homogeneous materials. Where designed to be soldered at high temperatures, "RoHS" products are suitable for use in specified lead-free processes. TI may reference these types of products as "Pb-Free".

RoHS Exempt: TI defines "RoHS Exempt" to mean products that contain lead but are compliant with EU RoHS pursuant to a specific EU RoHS exemption.

Green: TI defines "Green" to mean the content of Chlorine (Cl) and Bromine (Br) based flame retardants meet JS709B low halogen requirements of <=1000ppm threshold. Antimony trioxide based flame retardants must also meet the <=1000ppm threshold requirement.

(3) MSL, Peak Temp. - The Moisture Sensitivity Level rating according to the JEDEC industry standard classifications, and peak solder temperature.

(4) There may be additional marking, which relates to the logo, the lot trace code information, or the environmental category on the device.

(5) Multiple Device Markings will be inside parentheses. Only one Device Marking contained in parentheses and separated by a "~" will appear on a device. If a line is indented then it is a continuation of the previous line and the two combined represent the entire Device Marking for that device.

(6) Lead finish/Ball material - Orderable Devices may have multiple material finish options. Finish options are separated by a vertical ruled line. Lead finish/Ball material values may wrap to two lines if the finish value exceeds the maximum column width.

Important Information and Disclaimer:The information provided on this page represents TI's knowledge and belief as of the date that it is provided. TI bases its knowledge and belief on information provided by third parties, and makes no representation or warranty as to the accuracy of such information. Efforts are underway to better integrate information from third parties. TI has taken and continues to take reasonable steps to provide representative and accurate information but may not have conducted destructive testing or chemical analysis on incoming materials and chemicals. TI and TI suppliers consider certain information to be proprietary, and thus CAS numbers and other limited information may not be available for release.

In no event shall TI's liability arising out of such information exceed the total purchase price of the TI part(s) at issue in this document sold by TI to Customer on an annual basis.

TAPE AND REEL INFORMATION

QUADRANT ASSIGNMENTS FOR PIN 1 ORIENTATION IN TAPE

*All dimensions are nominal

Device	Package Type	Package Drawing	Pins	SPQ	Reel Diameter (mm)	Reel Width W1 (mm)	A0 (mm)	B0 (mm)	K0 (mm)	P1 (mm)	W (mm)	Pin1 Quadrant
TPS22981RGPR	QFN	RGP	20	3000	330.0	12.4	4.25	4.25	1.15	8.0	12.0	Q2
TPS22981RGPT	QFN	RGP	20	250	180.0	12.4	4.25	4.25	1.15	8.0	12.0	Q2

TAPE AND REEL BOX DIMENSIONS

*All dimensions are nominal

Device	Package Type	Package Drawing	Pins	SPQ	Length (mm)	Width (mm)	Height (mm)
TPS22981RGPR	QFN	RGP	20	3000	346.0	346.0	33.0
TPS22981RGPT	QFN	RGP	20	250	210.0	185.0	35.0

GENERIC PACKAGE VIEW

RGP 20

VQFN - 1 mm max height

4 x 4, 0.5 mm pitch

VERY THIN QUAD FLATPACK

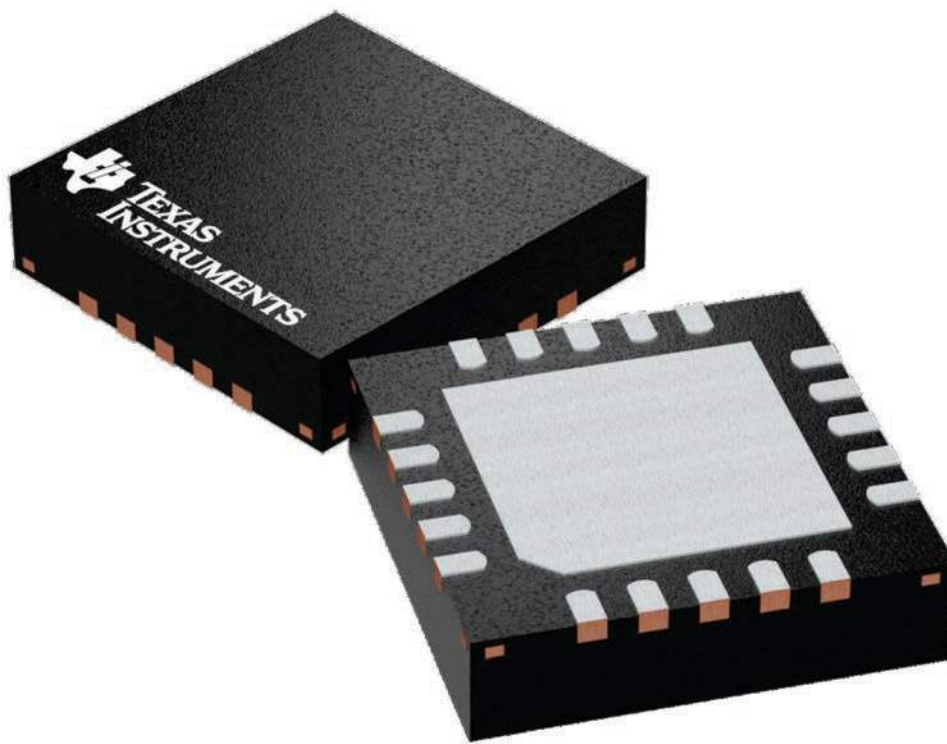

Images above are just a representation of the package family, actual package may vary.
Refer to the product data sheet for package details.

4224735/A

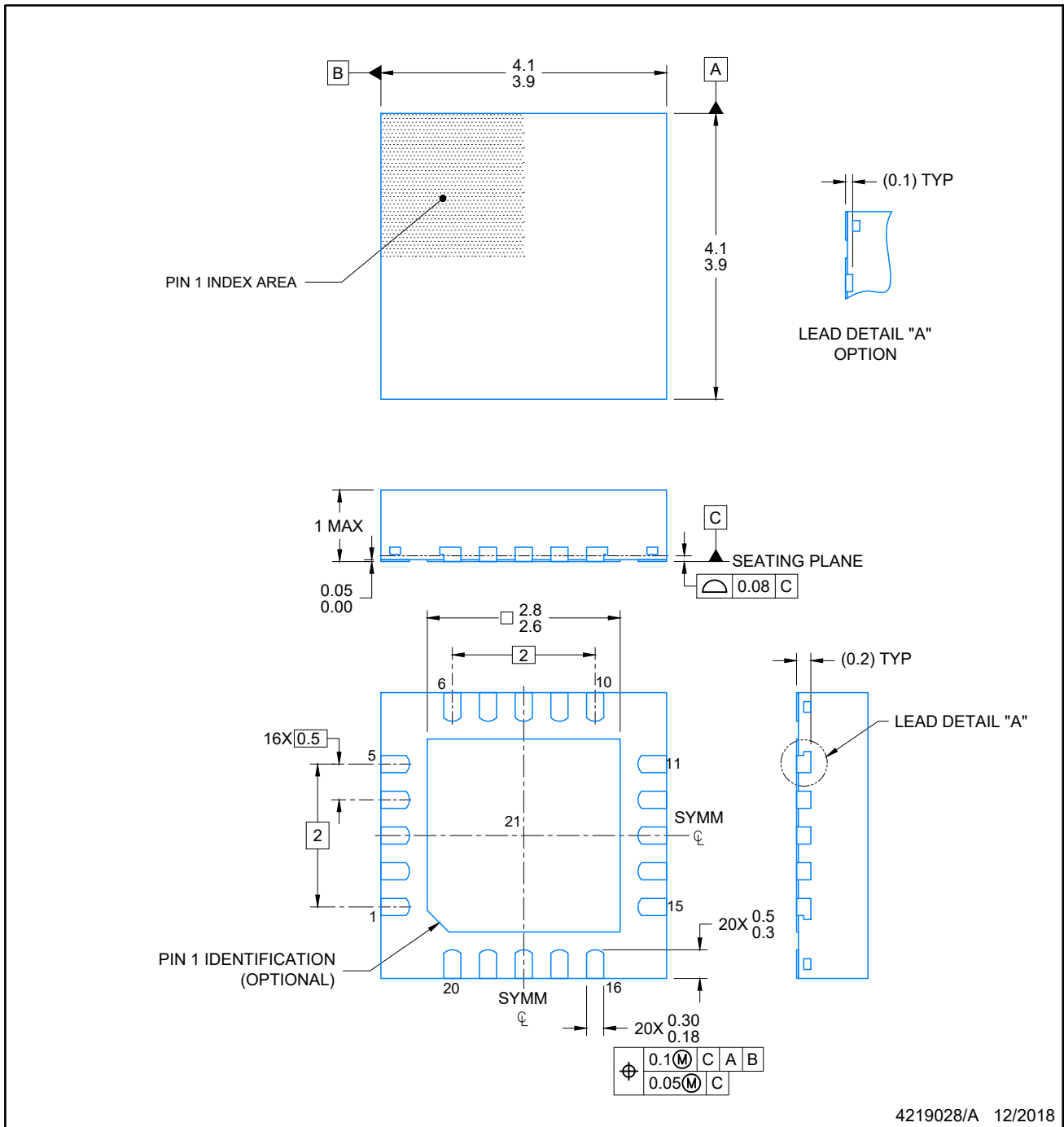

4219028/A 12/2018

NOTES:

1. All linear dimensions are in millimeters. Any dimensions in parenthesis are for reference only. Dimensioning and tolerancing per ASME Y14.5M.
2. This drawing is subject to change without notice.
3. The package thermal pad must be soldered to the printed circuit board for optimal thermal and mechanical performance.

EXAMPLE BOARD LAYOUT

VQFN - 1 mm max height

RGP0020D

PLASTIC QUAD FLATPACK- NO LEAD

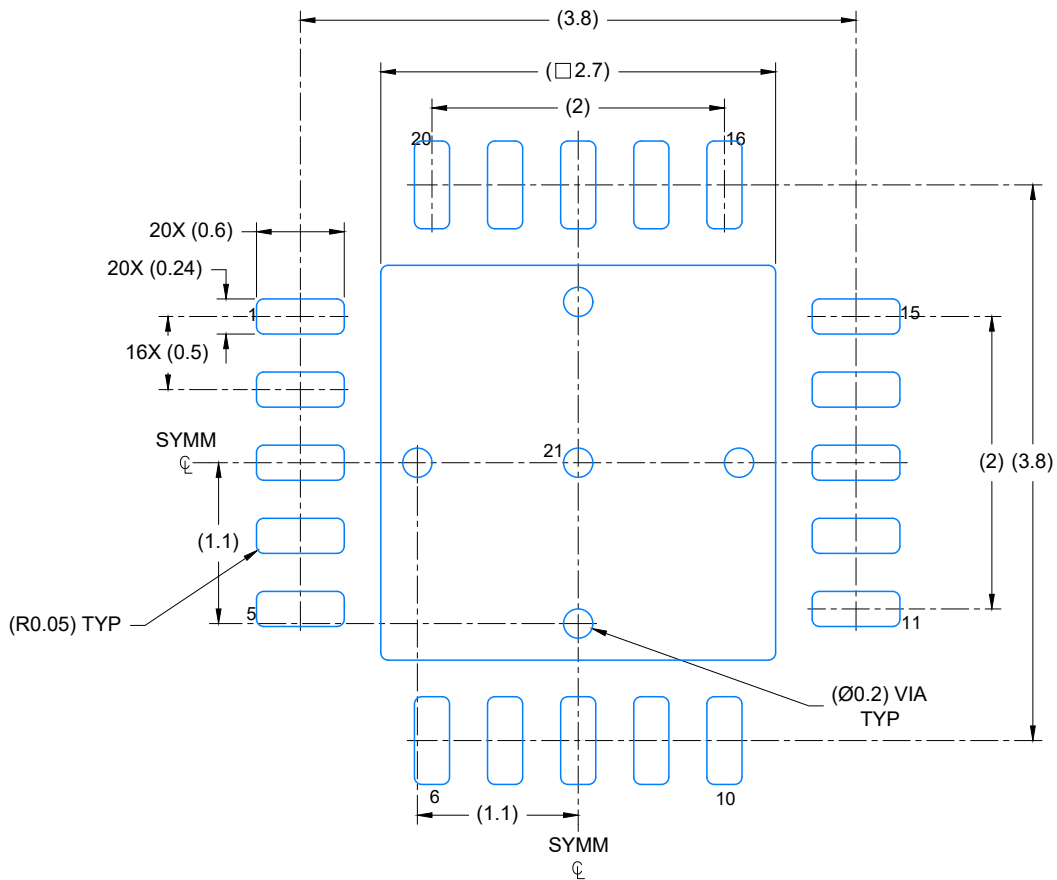

LAND PATTERN EXAMPLE
EXPOSED METAL SHOWN
SCALE: 20X

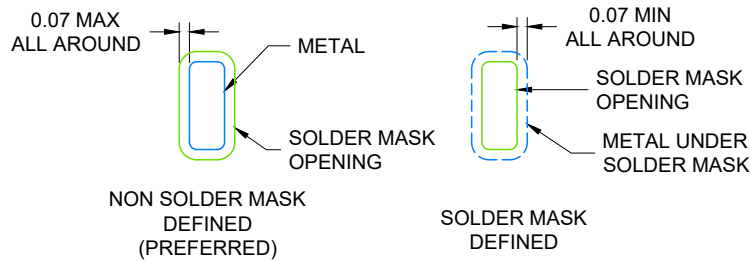

SOLDER MASK DETAILS

4219028/A 12/2018

NOTES: (continued)

4. This package is designed to be soldered to a thermal pad on the board. For more information, see Texas Instruments literature number SLUA271 (www.ti.com/lit/sluea271).
5. Vias are optional depending on application, refer to device data sheet. If any vias are implemented, refer to their locations shown on this view. It is recommended that vias under paste be filled, plugged or tented.

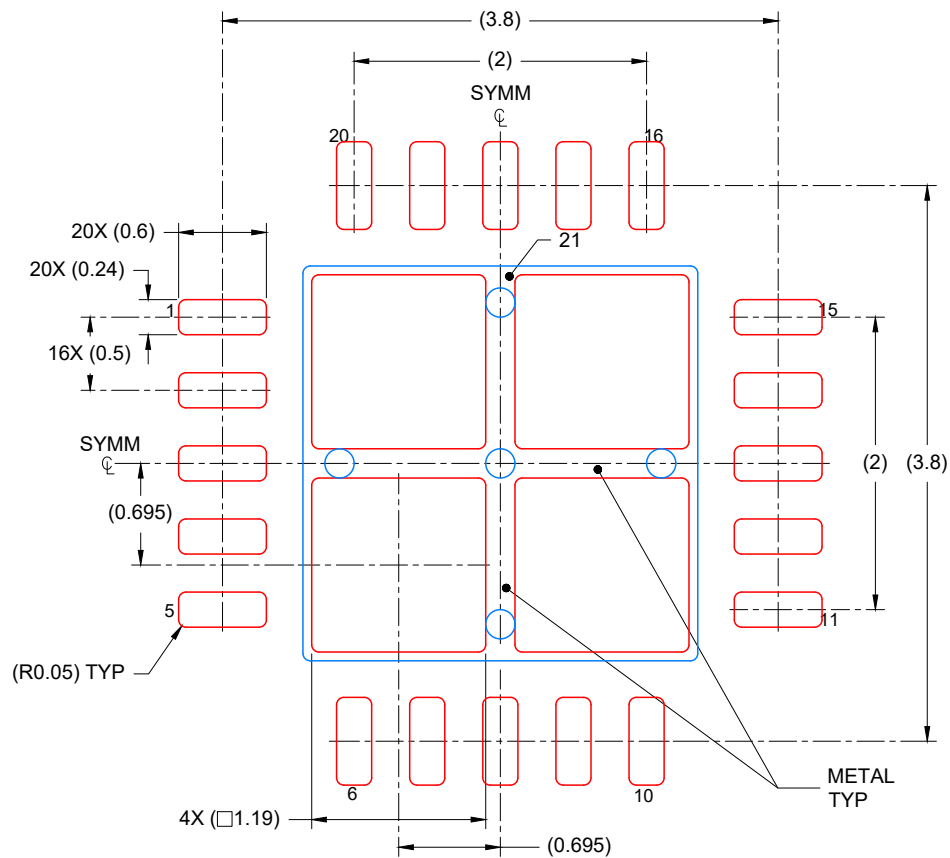

SOLDER PASTE EXAMPLE
 BASED ON 0.125 mm THICK STENCIL

EXPOSED PAD
 77% PRINTED COVERAGE BY AREA
 SCALE: 20X

4219028/A 12/2018

NOTES: (continued)

- 6. Laser cutting apertures with trapezoidal walls and rounded corners may offer better paste release. IPC-7525 may have alternate design recommendations.

IMPORTANT NOTICE AND DISCLAIMER

TI PROVIDES TECHNICAL AND RELIABILITY DATA (INCLUDING DATA SHEETS), DESIGN RESOURCES (INCLUDING REFERENCE DESIGNS), APPLICATION OR OTHER DESIGN ADVICE, WEB TOOLS, SAFETY INFORMATION, AND OTHER RESOURCES "AS IS" AND WITH ALL FAULTS, AND DISCLAIMS ALL WARRANTIES, EXPRESS AND IMPLIED, INCLUDING WITHOUT LIMITATION ANY IMPLIED WARRANTIES OF MERCHANTABILITY, FITNESS FOR A PARTICULAR PURPOSE OR NON-INFRINGEMENT OF THIRD PARTY INTELLECTUAL PROPERTY RIGHTS.

These resources are intended for skilled developers designing with TI products. You are solely responsible for (1) selecting the appropriate TI products for your application, (2) designing, validating and testing your application, and (3) ensuring your application meets applicable standards, and any other safety, security, regulatory or other requirements.

These resources are subject to change without notice. TI grants you permission to use these resources only for development of an application that uses the TI products described in the resource. Other reproduction and display of these resources is prohibited. No license is granted to any other TI intellectual property right or to any third party intellectual property right. TI disclaims responsibility for, and you will fully indemnify TI and its representatives against, any claims, damages, costs, losses, and liabilities arising out of your use of these resources.

TI's products are provided subject to [TI's Terms of Sale](#) or other applicable terms available either on [ti.com](https://www.ti.com) or provided in conjunction with such TI products. TI's provision of these resources does not expand or otherwise alter TI's applicable warranties or warranty disclaimers for TI products.

TI objects to and rejects any additional or different terms you may have proposed.

Mailing Address: Texas Instruments, Post Office Box 655303, Dallas, Texas 75265
Copyright © 2023, Texas Instruments Incorporated