

MATERIAL NO.	ENG. NO.	MATERIAL NO. TAPE MOUNTED	ENG. NO. TAPE MOUNTED	STUD SIZE	"S" ±.005/-.127	"K" REF DIA	WIRE RANGE AWG / MM <sup>2</sup>	INSULATION COLOR	I.D. MIN	MWID
190770009	SRA-S-829-06	190770010	SRA-S-829-06T	6	.146 (3.71)	.236 (5.99)	22-18/1.25-1.3	RED	.062/1.57	.138/3.51
190770011	SRA-S-829-08	190770012	SRA-S-829-08T	8	.173 (4.39)	.263 (6.68)				
190770013	SRA-S-829-10	190770014	SRA-S-829-10T	10	.198 (5.03)	.288 (7.32)				
190770021	SRB-S-829-06	190770022	SRB-S-829-06T	6	.146 (3.71)	.236 (5.99)	16-14/1.0-2.6	BLUE	.086/2.18	.169/4.29
190770023	SRB-S-829-08	190770024	SRB-S-829-08T	8	.173 (4.39)	.263 (6.68)				
190770025	SRB-S-829-10	190770026	SRB-S-829-10T	10	.198 (5.03)	.288 (7.32)				

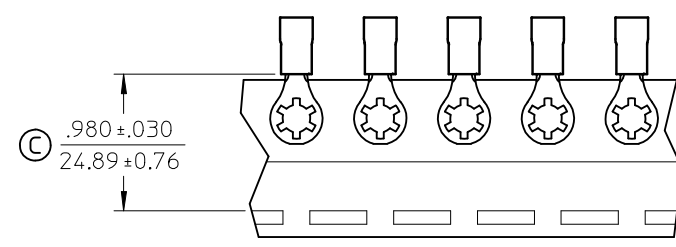
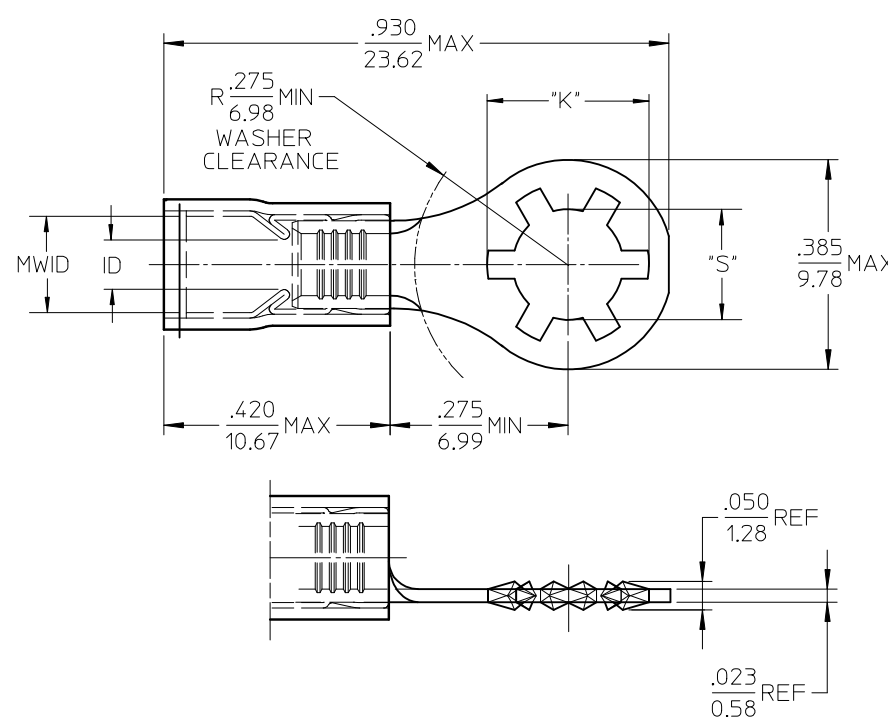

SALES DRAWING

- NOTES:
1. MATERIAL: STEEL.  
PLATING: ELECTROPLATE TIN.
  2. FERRULE: BRASS ELECTROPLATE TIN.  
PLATING: ELECTROPLATE TIN.
  3. INSULATION: NYLON.
  4. MWID=MAXIMUM WIRE INSULATION DIA.
  5. ALL DIMENSIONS IN INCHES (MM).
  6. ALL COMPONENTS ARE ROHS COMPLIANT. ©

<b>MODIFY TOL.</b> EC NO: ETC2006-0425 IDRMN: CYORK 2006/05/08 CHKD: JMACNEIL 2006/05/11 APPR: RDEROSS 2006/05/11	QUALITY SYMBOLS ▽ - 0 ∇ - 0	GENERAL TOLERANCES (UNLESS SPECIFIED)		SCALE 1:1	DESIGN UNITS INCH	THIRD ANGLE PROJECTION	REVISE ON CAD ONLY	
		mm	INCH	DIMENSION STYLE IN/MM		TITLE		
		4 PLACES ± --- ± ---	3 PLACES ± --- ± .005	DRAWN BY DMYRICK	DATE 03/12/22	AVIKRIMP STEEL STAR RING TONGUE TERMINALS MOLEX INCORPORATED		
		2 PLACES ± 0.13 ± .01	1 PLACE ± 0.25 ± ---	CHECKED BY SBEITZEL	DATE 03/12/22			
ANGULAR ± 1/2°		APPROVED BY RDEROSS		DATE 03/12/22	MATERIAL NO. SEE CHART	DOCUMENT NO. SD-19077-002	SHEET NO. 1 OF 1	
DRAFT WHERE APPLICABLE MUST REMAIN WITHIN DIMENSIONS		THIS DRAWING CONTAINS INFORMATION THAT IS PROPRIETARY TO MOLEX INCORPORATED AND SHOULD NOT BE USED WITHOUT WRITTEN PERMISSION						