



LOW-VOLTAGE 10-BIT BUS SWITCH WITH PRECHARGED OUTPUTS

IDT74CBTLV6800

FEATURES:

- Functionally equivalent to QS3800
- 5Ω A/B bi-directional switch
- Isolation under power-off conditions
- Over-voltage tolerant
- Latch-up performance exceeds 100mA
- V_{CC} = 2.3V - 3.6V, Normal Range
- ESD > 2000V per MIL-STD-883, Method 3015;
> 200V using machine model (C = 200pF, R = 0)
- Available in QSOP and TSSOP packages

APPLICATIONS:

- 3.3V High Speed Bus Switching and Bus Isolation

DESCRIPTION:

The CBTLV6800 provides 10-bits of high-speed bus switching with low on-state resistance of the switch allowing connections to be made with minimal propagation delay. The device also precharges the B port to a user-selectable bias voltage (BIASV) to minimize live-insertion noise.

The CBTLV6800 is organized as a single 10-bit bus switch with a single output-enable (\overline{OE}) input. When \overline{OE} is low, the 10-bit bus switch is on and port A is connected to port B. When \overline{OE} is high, the switch is open, and a high impedance state exists between the two ports, and port B is precharged to BIASV through the equivalent of a 10-kΩ resistor.

To ensure the high-impedance state during power up or power down, \overline{OE} should be tied to V_{CC} through a pullup resistor; the minimum value of the resistor is determined by the current-sinking capability of the driver.

FUNCTIONAL BLOCK DIAGRAM

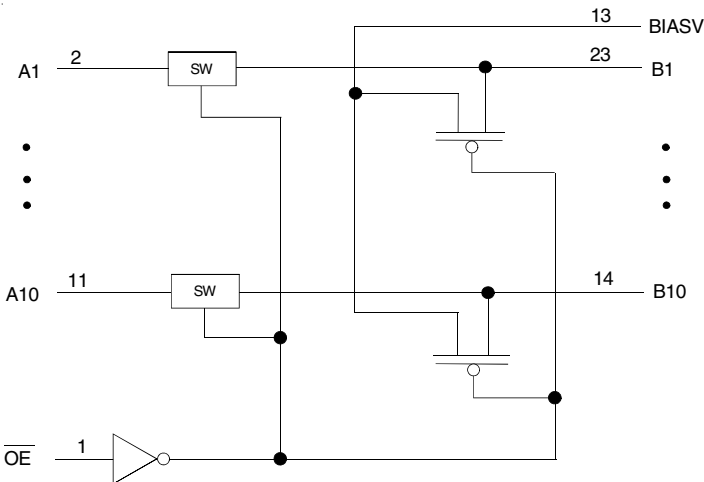

SIMPLIFIED SCHEMATIC, EACH SWITCH

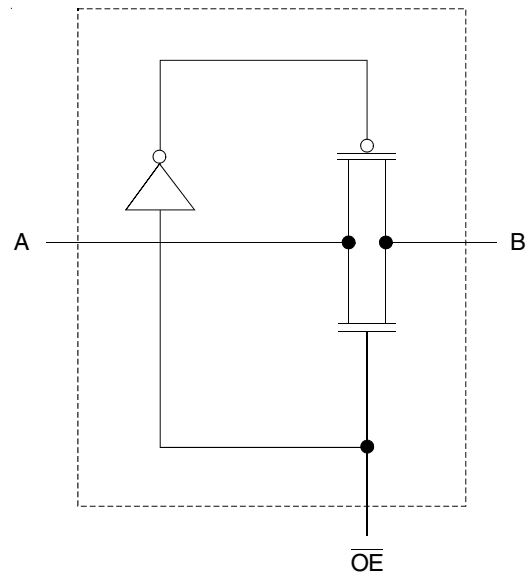

PIN CONFIGURATION

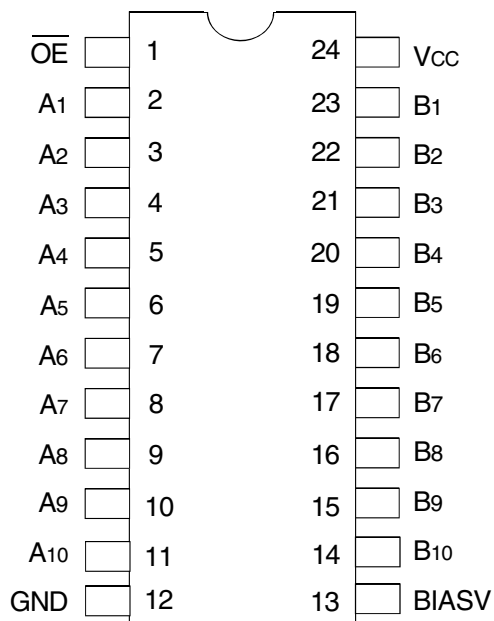

QSOP / TSSOP
 TOP VIEW

ABSOLUTE MAXIMUM RATINGS⁽¹⁾

Symbol	Description	Max	Unit
V _{CC}	Supply Voltage Range	-0.5 to +4.6	V
V _I	Input Voltage Range	-0.5 to +4.6	V
	Continuous Channel Current	128	mA
I _{IK}	Input Clamp Current, V _{I/O} < 0	-50	mA
T _{STG}	Storage Temperature	-65 to +150	°C

NOTE:

1. Stresses greater than those listed under ABSOLUTE MAXIMUM RATINGS may cause permanent damage to the device. This is a stress rating only and functional operation of the device at these or any other conditions above those indicated in the operational sections of this specification is not implied. Exposure to absolute maximum rating conditions for extended periods may affect reliability.

FUNCTION TABLE⁽¹⁾

Input \overline{OE}	Inputs/Outputs
L	A Port = B Port
H	A Port = Z B Port = BIASV

NOTE:

1. H = HIGH Voltage Level
 L = LOW Voltage Level
 Z = High-Impedance

OPERATING CHARACTERISTICS, T_A = 25°C⁽¹⁾

Symbol	Parameter	Test Conditions	Min.	Max.	Unit
V _{CC}	Supply Voltage		2.3	3.6	V
BIASV	Bias Voltage		1.3	V _{CC}	V
V _{IH}	High-Level Control Input Voltage	V _{CC} = 2.3V to 2.7V	1.7	—	V
		V _{CC} = 2.7V to 3.6V	2	—	
V _{IL}	Low-Level Control Input Voltage	V _{CC} = 2.3V to 2.7V	—	0.7	V
		V _{CC} = 2.7V to 3.6V	—	0.8	
T _A	Operating Free-Air Temperature		-40	85	°C

NOTE:

1. All unused control inputs of the device must be held at V_{CC} or GND to ensure proper device operation.

DC ELECTRICAL CHARACTERISTICS OVER OPERATING RANGE

Following Conditions Apply Unless Otherwise Specified:

Operating Conditions: $T_A = -40^{\circ}\text{C}$ to $+85^{\circ}\text{C}$

Symbol	Parameter	Test Conditions	Min.	Typ.	Max.	Unit	
V_{IK}	Control Inputs, Data Inputs	$V_{CC} = 3\text{V}$, $I_I = -18\text{mA}$	—	—	-1.2	V	
I_I	Control Inputs	$V_{CC} = 3.6\text{V}$, $V_I = V_{CC}$ or GND	—	—	± 1	μA	
I_{OZ}	Data I/O	$V_{CC} = 3.6\text{V}$, $V_O = 0$ or 3.6V , switch disabled	—	—	± 20	μA	
I_{OFF}		$V_{CC} = 0$, V_I or $V_O = 0$ to 3.6V	—	—	50	μA	
$ I_O $		$V_{CC} = 3\text{V}$, $\text{BIASV} = 2.4\text{V}$, $V_O = 0$, $\overline{\text{OE}} = V_{CC}$	0.25	—	—	mA	
I_{CC}		$V_{CC} = 3.6\text{V}$, $I_O = 0$, $V_I = V_{CC}$ or GND	—	—	10	μA	
$\Delta I_{CC}^{(1)}$	Control Inputs	$V_{CC} = 3.6\text{V}$, one input at 3V , other inputs at V_{CC} or GND	—	—	300	μA	
C_I	Control Inputs	$V_I = 3\text{V}$ or 0	—	4	—	pF	
$C_{IO(OFF)}$		$V_O = 3\text{V}$ or 0 , switch OFF, $\text{BIASV} = \text{Open}$, $\overline{\text{OE}} = V_{CC}$	—	7	—	pF	
$R_{ON}^{(2)}$	$V_{CC} = 2.3\text{V}$ Typ. at $V_{CC} = 2.5\text{V}$	$V_I = 0$	$I_I = 64\text{mA}$	—	5	8	Ω
			$I_I = 24\text{mA}$	—	5	8	
	$V_{CC} = 3\text{V}$	$V_I = 1.7\text{V}$	$I_I = 15\text{mA}$	—	27	40	
			$I_I = 64\text{mA}$	—	5	7	
	$V_{CC} = 3\text{V}$	$V_I = 0$	$I_I = 24\text{mA}$	—	5	7	
			$I_I = 15\text{mA}$	—	10	15	

NOTES:

- The increase in supply current is attributable to each current that is at the specified voltage level rather than V_{CC} or GND.
- This is measured by the voltage drop between the A and B terminals at the indicated current through the switch. On-state resistance is determined by the lower of the voltages of the two (A or B) terminals.

SWITCHING CHARACTERISTICS

Symbol	Parameter	$V_{CC} = 2.5\text{V} \pm 0.2\text{V}$		$V_{CC} = 3.3\text{V} \pm 0.3\text{V}$		Unit
		Min.	Max.	Min.	Max.	
$t_{PD}^{(1)}$	Propagation Delay A to B or B to A	—	0.15	—	0.25	ns
t_{PZH} t_{PZL}	$\text{BIASV} = 3\text{V}$ or GND $\overline{\text{OE}}$ to A or B	1	4.8	1	4.5	ns
t_{PHZ} t_{PLZ}	$\text{BIASV} = 3\text{V}$ or GND $\overline{\text{OE}}$ to A or B	1	5.6	1	5.5	ns

- NOTE:
- The propagation delay is the calculated RC time constant of the typical on-state resistance of the switch and the specified load capacitance driven by an ideal voltage source (zero output impedance).

TEST CIRCUITS AND WAVEFORMS

TEST CONDITIONS

Symbol	$V_{CC}^{(1)} = 3.3V \pm 0.3V$	$V_{CC}^{(2)} = 2.5V \pm 0.2V$	Unit
V _{LOAD}	6	2 x V _{CC}	V
V _{IH}	3	V _{CC}	V
V _T	1.5	V _{CC} / 2	V
V _{LZ}	300	150	mV
V _{HZ}	300	150	mV
C _L	50	30	pF

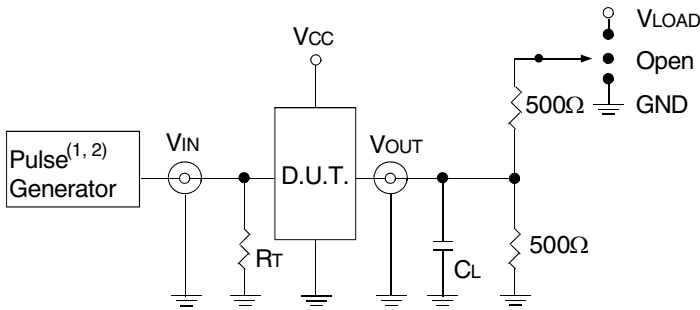

Test Circuits for All Outputs

DEFINITIONS:

C_L = Load capacitance: includes jig and probe capacitance.
 R_T = Termination resistance: should be equal to Z_{OUT} of the Pulse Generator.

NOTES:

1. Pulse Generator for All Pulses: Rate ≤ 10MHz; t_r ≤ 2.5ns; t_f ≤ 2.5ns.
2. Pulse Generator for All Pulses: Rate ≤ 10MHz; t_r ≤ 2ns; t_f ≤ 2.5ns.

SWITCH POSITION

Test	Switch
t _{PLZ} /t _{PZL}	V _{LOAD}
t _{PHZ} /t _{PZH}	GND
t _{PD}	Open

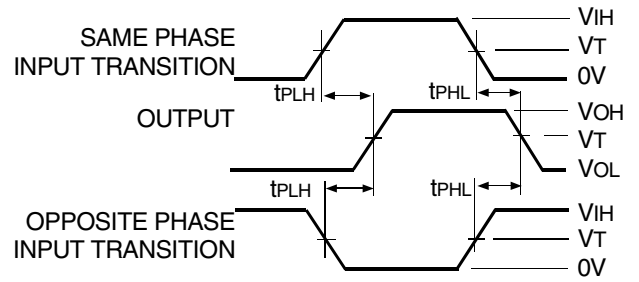

Propagation Delay

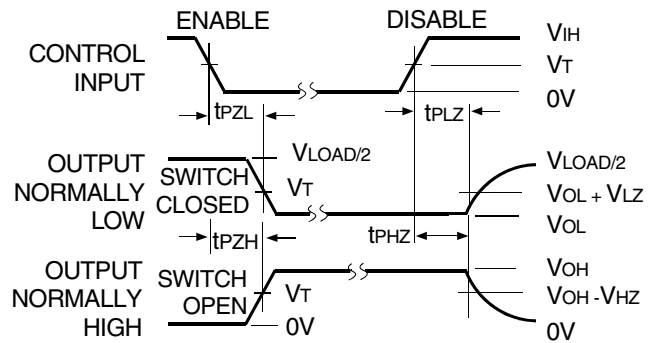

Enable and Disable Times

ORDERING INFORMATION

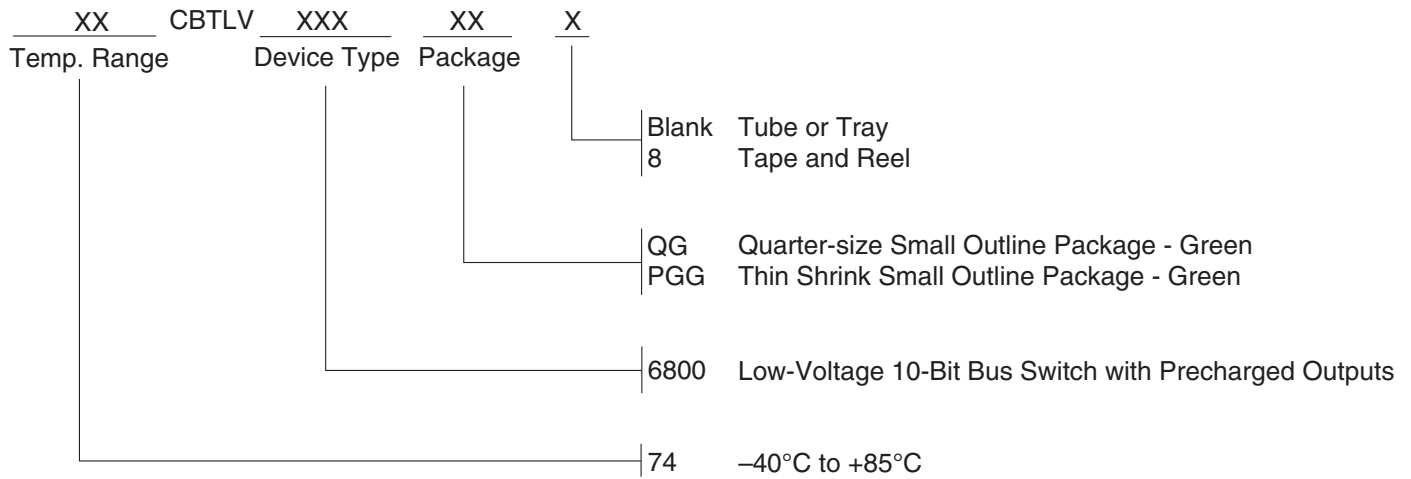

Datasheet Document History

12/18/2014 Pg. 5 Updated the ordering information by removing the "IDT" notation, non RoHS part and by adding Tape and Reel information.



CORPORATE HEADQUARTERS
6024 Silver Creek Valley Road
San Jose, CA 95138

for SALES:
800-345-7015 or 408-284-8200
fax: 408-284-2775
www.idt.com

for Tech Support:
logichelp@idt.com