

PART NUMBER	REVISION	DESCRIPTION	FEED TYPE
2266354-1	B	FINE CRIMP HEIGHT ADJUST	MECHANICAL
2266354-2	B	FINE CRIMP HEIGHT ADJUST	PNEUMATIC
7-2266354-1	B	MECHANICAL AND CRIMP TOOLING KIT	MECHANICAL
7-2266354-2	B	PNEUMATIC AND CRIMP TOOLING KIT	PNEUMATIC
7-2266354-7	A	CRIMP TOOLING KIT	-

ATLANTIC VERSION TERMINATOR INTERFACE ADAPTER

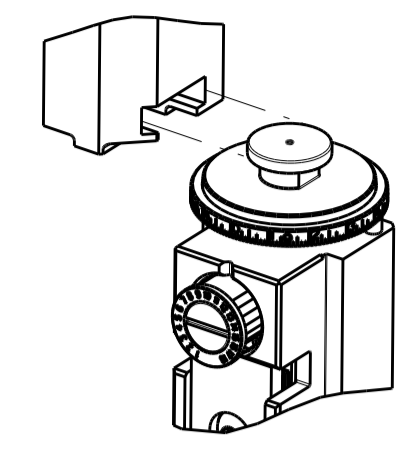

APPLICATOR DATA		
CRIMP	SIZE	TYPE
WIRE	1.40 mm [.055]	F
INSUL	2.79 mm [.110]	O

APPLICATOR INSTRUCTIONS  
408-35042

TERMINAL DATA: KOSTAL TERMINAL KOSTAL CRIMP SPECIFICATION	
TERMINAL NAME: KOSTAL RECEPTACLE SWS MLK1.2	
WIRE STRIP LENGTH 3.10-3.60 mm [1.22-.142 IN]	INSULATION DIAMETER RANGE Ø1.10-1.70 mm [0.043-.067 IN]
TERMINAL APPLICATION SPECIFICATION	DOC00061540 Rev A

TERMINALS APPLIED				
TE TERMINAL	KOSTAL TERMINAL	TE SEAL	KOSTAL SEAL	SEAL INSULATION DIAMETER RANGE
1572458-1	22140614110	1949520-1	10800507250	
1572458-2	22124614110	1572751-1	10800444521	Ø1.10-1.70
1572458-3	22125614110			
2113493-1	32124680640			
2113493-2	32125680640			
2113493-3	32140680640			
286939-1	22140492680			
286939-2	22124492680			
286939-3	22125492680			

WIRE SIZE	CRIMP HEIGHT mm [INCH]	CRIMP HEIGHT REFERENCE SETTING
0.50mm <sup>2</sup>	0.90 +/- 0.03 [0.035 +/- .001]	5.2
0.35mm <sup>2</sup>	0.80 +/- 0.03 [0.031 +/- .001]	6.3
0.22mm <sup>2</sup> or 0.25mm <sup>2</sup>	0.75 +/- 0.03 [0.030 +/- .001]	6.9

- 1 RECOMMENDED SPARE PARTS
- 2 REFER TO SUPPLIED INSTRUCTION SHEET FOR CLEANING, LUBRICATION AND STORAGE OF APPLICATOR.
- 3 APPLY PART NUMBER 2-23419-6 LOCTITE TO THREADS OF ITEM 242.
- 4 CRIMP HEIGHT REFERENCE SETTING WAS THE SETTING USED WHEN THE APPLICATOR WAS QUALIFIED AT THE FACTORY. ADJUSTMENT MAY BE NECESSARY WHEN RUNNING APPLICATOR IN THE FIELD.
- 5 CUT TO LENGTH AT ASSEMBLY
- 6. UNLESS SPECIFIED OTHERWISE TORQUE VALUES SHALL BE USED PER DOCUMENT, 101-35000.

**\*WARNING**  
ON INSTALLATION, SET WIRE DISC TO CRIMP HEIGHT REFERENCE SETTING FOR LARGEST WIRE SIZE. CRIMP HEIGHT REFERENCE SETTINGS GREATER THAN THE VALUE SHOWN MAY CAUSE DAMAGE TO THE CRIMP TOOLING, REFER TO THE INSTRUCTION SHEET FOR PROPER SETUP AND ADJUSTMENTS.

LOC	DIST	REVISIONS					
A	66	P	LTN	DESCRIPTION	DATE	OWN	APVD
		A		RELEASED	13AUG2014	BW	GB
		B		ECR-20-000251	08JAN2020	F.J	TE

-	1	-	1	-	2119641-1	FEED CAM, AIR FEED	248
-	1	1	1	1	2119082-4	CAM, SNAIL, INSULATION ADJUSTMENT	244
-	1	1	1	1	2079764-1	WASHER, WAVE SPRING, CREST-TO-CREST	243
-	1	1	1	1	2119083-1	RETAINER, INSULATION DIAL	242
-	1	1	1	1	7-18023-7	SCR, SKT HD CAP M3 X 4.0	241
-	-	1	-	1	2119580-1	MECHANICAL FEED ASSEMBLY	239
-	1	-	1	-	2844940-1	AIR FEED MODULE	238
-	REF	REF	REF	REF	994970-2	COUNTER, MAGNETIC	164
-	1	1	1	1	2844908-1	SCREW, LOCKING	99
-	1	1	1	1	2844907-1	POST, LOCKING	98
-	1	1	1	1	455888-6	SPACER, CRIMPER	82
-	1	1	1	1	1803607-3	DOCUMENTATION PACKAGE	71
-	1	1	1	1	2119740-1	TAG, IDENTIFICATION	67
-	2	2	2	2	2168078-1	SCREW, DRIVE, RH, RoHS, 2 x .188	66
-	1	1	1	1	2168083-2	SCR, SKT HD CAP, RoHS, M4 X 8.0	60
-	1	1	1	1	5-18022-5	SCR, HEX HD CAP, M4 X 6.0	59
-	1	1	1	1	985575-3	SCR, FLT SKT HD CAP M3 X 10.0	57
-	1	1	1	1	1338683-8	FEED PAWL	56
-	4	4	4	4	2168083-3	SCR, SKT HD CAP, RoHS, M4 X 12.0	54
-	2	2	2	2	2168083-8	SCR, SKT HD CAP, RoHS, M4 X 16	53
-	1	1	1	1	5018030-1	NUT, HEX, REG, RoHS, M3	52
-	1	1	1	1	811242-5	BUMPER, HOLD DOWN	51
-	1	1	1	1	690753-2	SPACER, TONKER	50
-	1	2	1	2	18023-9	SCR, SKT HD CAP M4 X 6.0	49
-	-	1	-	1	2119652-1	FEED CAM, PRE FEED	48
-	-	1	-	1	2119653-1	FEED CAM, POST FEED	47
-	1	1	1	1	1803583-9	APPLICATOR BASIC ASSEMBLY, SF	46
-	1	1	1	1	1803515-1	RAM ASSEMBLY, SF ATLANTIC	44
-	1	1	1	1	1803602-1	SCR, BHSC, RoHS (M8 X 25)	41
-	1	1	1	1	2-1752356-0	SUPPORT, TERMINAL	34
-	2	2	2	2	2079383-5	SCR, BHSC, RoHS (M4 X 20)	33
-	2	2	2	2	2-2844962-8	SPACER, CYLINDRICAL, STRIP GUIDE	30
-	1	1	1	1	2844992-1	ASSEMBLY, STRIP GUIDE	29
-	1	1	1	1	455888-3	SPACER, CRIMPER	28
-	1	1	1	1	1320928-2	STRIP GUIDE	24
-	1	1	1	1	2168083-2	SCR, SKT HD CAP, RoHS, M4 X 8.0	21
-	2	2	2	2	1-18028-2	WASHER, FLAT, REG M4	20
-	1	1	1	1	2119533-1	STRIPPER, SIDE FEED	19
-	1	1	1	1	2119806-1	INSERT, SHEAR	13
-	1	1	1	1	3-22280-3	SPRING, COMPRESSION	12
-	1	1	1	1	1-356885-4	STOP, SHEAR	11
-	1	1	1	1	2119805-1	SHEAR HOLDER, FRONT	10
-	1	1	1	1	318707-1	FLOATING SHEAR, FRONT	9
-	1	2	2	1	1-1333201-1	ANVIL, COMBINATION	8
-	1	1	1	1	1-240641-6	SPACER	7
-	-	-	-	-	-	-	6
-	1	1	1	1	2-2119781-4	DEPRESSOR, SHEAR	5
-	1	1	1	1	3-238011-8	BLOCK, CRIMPER SPACER	4
-	1	2	2	1	6-1633965-3	CRIMPER, INSULATION O PREMIUM	3
-	1	1	1	1	455888-9	SPACER, CRIMPER	2
-	1	2	2	1	4-456402-5	CRIMPER, WIRE PREMIUM	1

ATLANTIC VERSION  
Shown on sheets 1 of 4 & 2 of 4  
(Pacific version shown on sheets 3 of 4 & 4 of 4)

DIMENSIONS:		TOLERANCES UNLESS OTHERWISE SPECIFIED:		MATERIAL:		FINISH:	
mm	0 PLC ±	1 PLC ±	2 PLC ±	3 PLC ±	4 PLC ±	ANGLES ±	

OWN	D. WEAVER	12MAR2014	
CHK	G. BAILEY	12MAR2014	
APVD	G. BAILEY	12MAR2014	
PRODUCT SPEC			
APPLICATION SPEC			
SIZE	CAGE CODE	DRAWING NO	RESTRICTED TO
A1	00779	2266354	
CUSTOMER DRAWING		SCALE	1:2
		SHEET	1 OF 4
		REV	B

LOC	DIST	REVISIONS					
A	66	P	LTN	DESCRIPTION	DATE	DWN	APVD
		-		SEE SHEET 1			

# FEED TYPE MECHANICAL

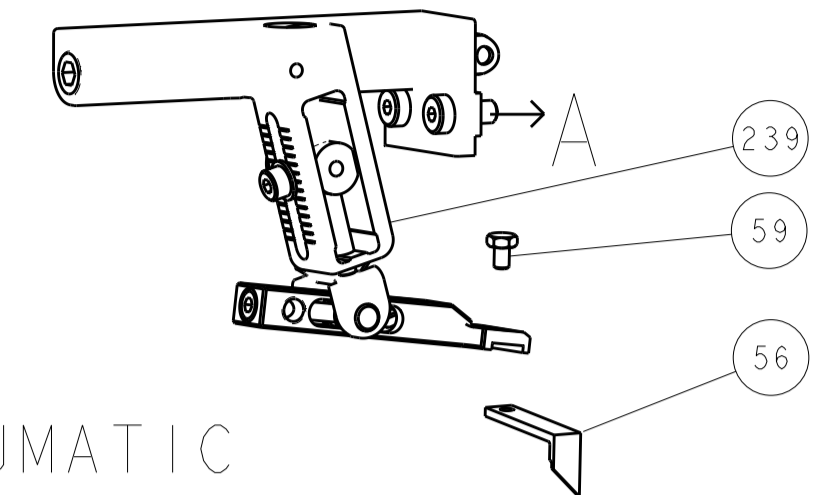

## PNEUMATIC

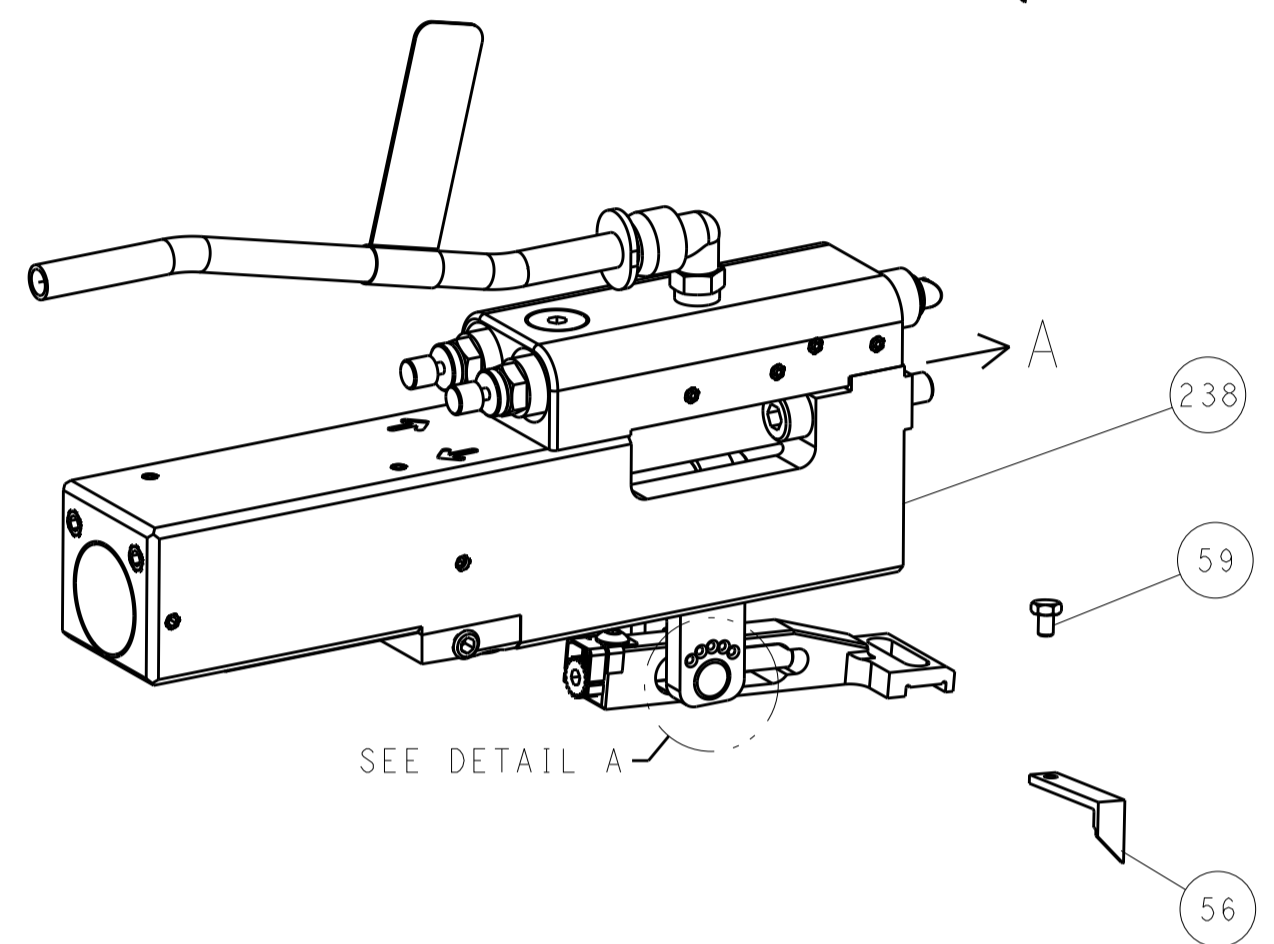

## FEED SPRING SETTING POSITION (SHOWN FROM REAR SIDE)

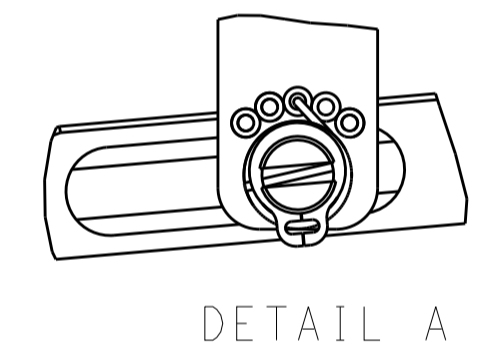

DETAIL A

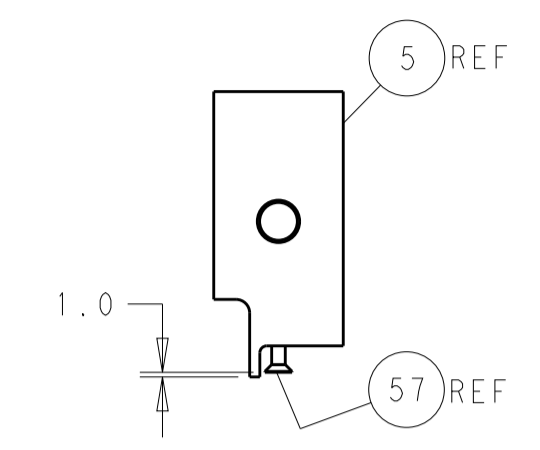
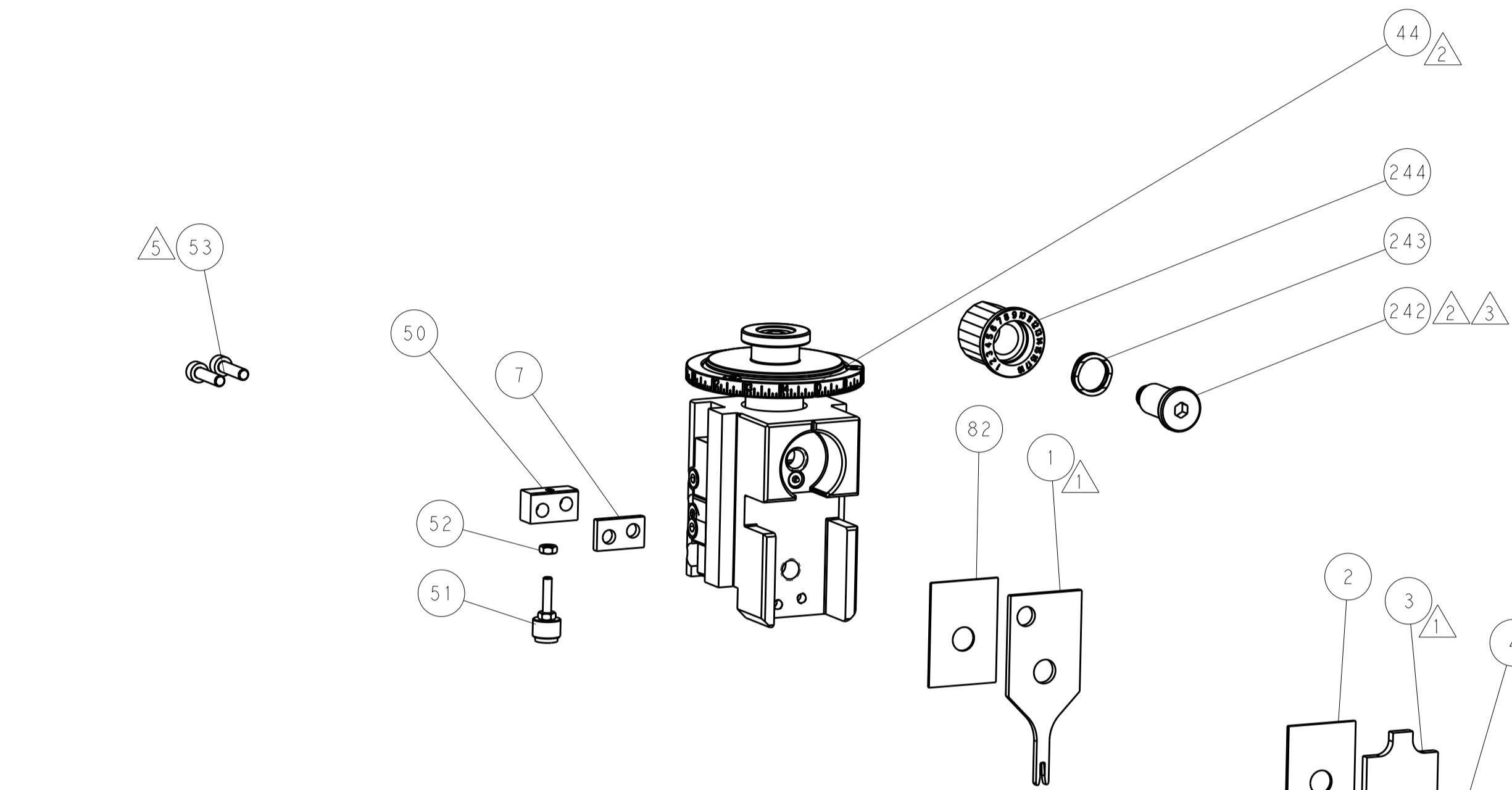

SHEAR DEPRESSOR DETAIL

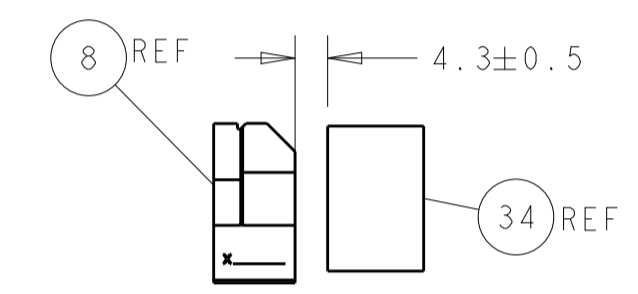

TERMINAL SUPPORT LOCATION

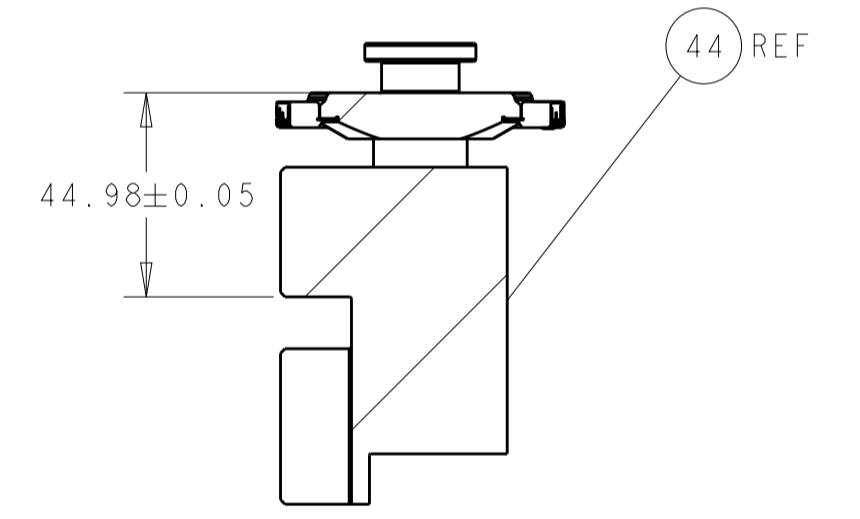

RAM SET-UP

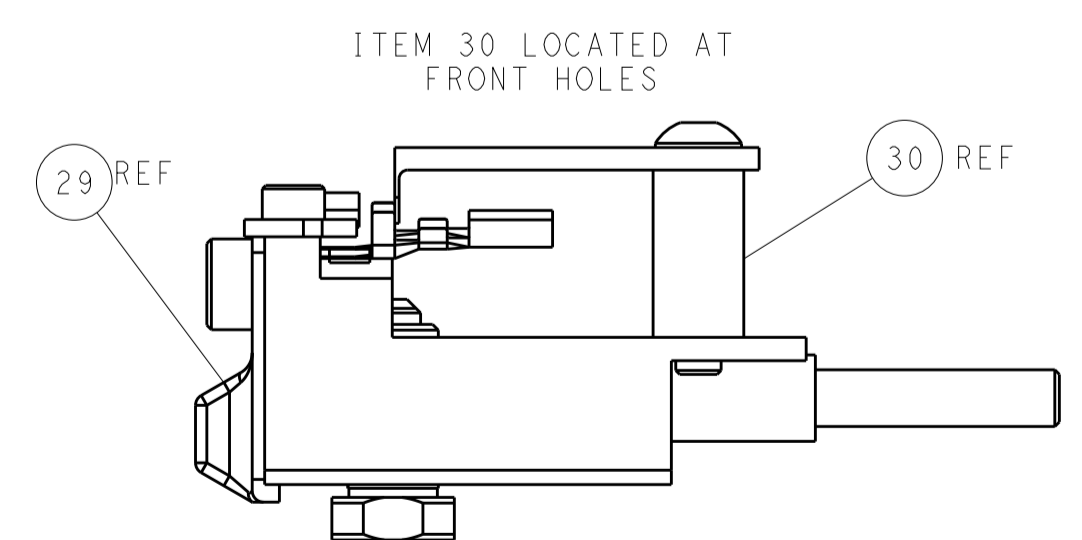
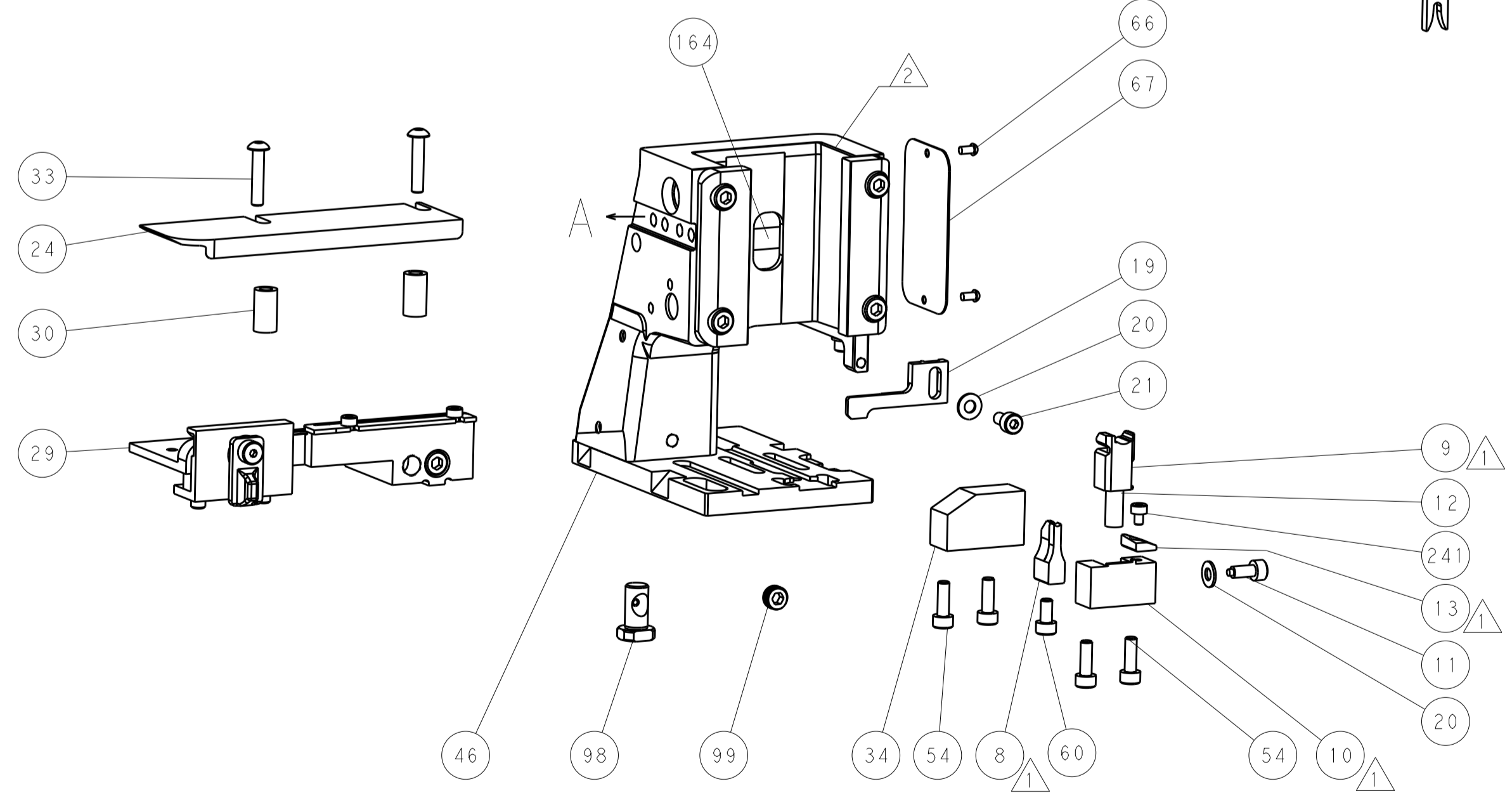

FEED TRACK POSITION GUIDE BY INSULATION BARREL

# CAM POSITIONS

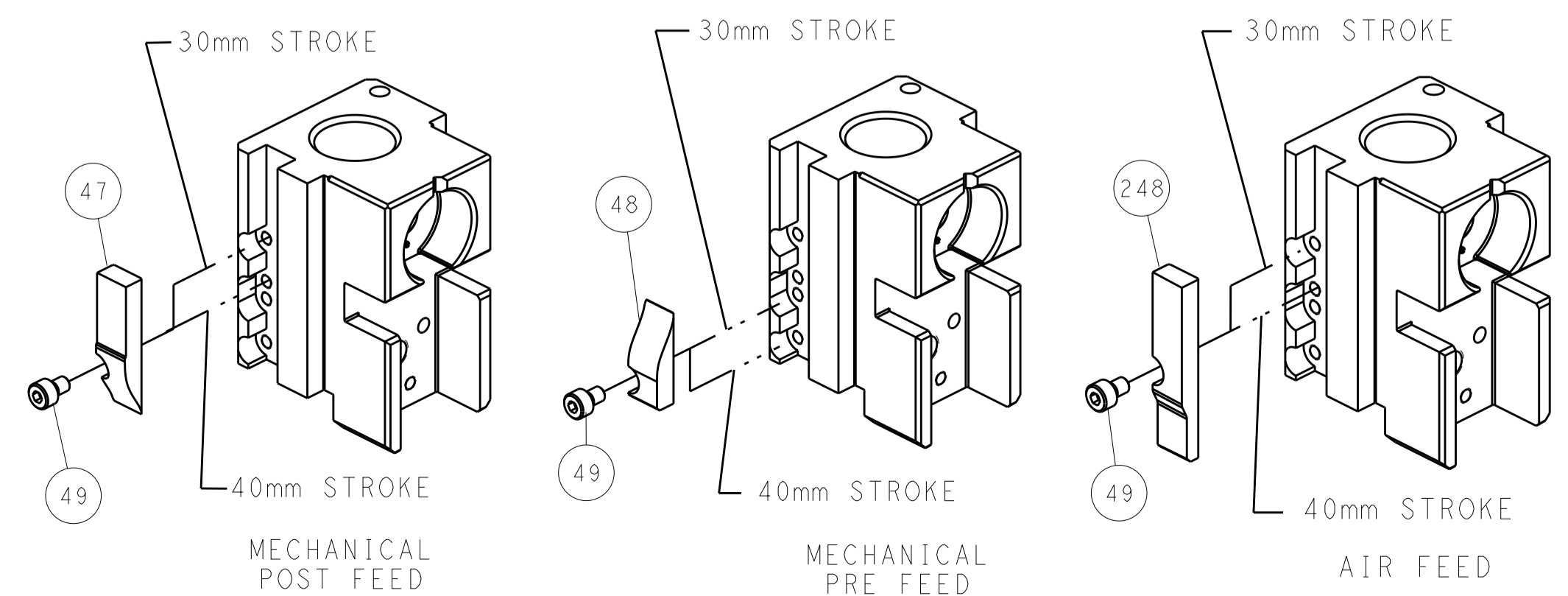

**ATLANTIC VERSION**  
 Shown on sheets 1 of 4 & 2 of 4  
 (Pacific version shown on sheets 3 of 4 & 4 of 4)

DIMENSIONS:		TOLERANCES UNLESS OTHERWISE SPECIFIED:		DWN B. WEAVER 12MAR2014		TE Connectivity	
mm	0 PLC ±	1 PLC ±	2 PLC ±	3 PLC ±	4 PLC ±	Harrisburg, PA 17105-3608	
MATERIAL:		FINISH:		CHK G. BAILEY 12MAR2014		NAME Ocean Side Feed Applicator	
CUSTOMER DRAWING		SCALE 1:2		APVD G. BAILEY 12MAR2014		RESTRICTED TO	
				PRODUCT SPEC		SIZE CAGE CODE DRAWING NO	
				APPLICATION SPEC		A11 00779 C=2266354	
				WEIGHT		SHEET 2 OF 4 REV B	

PART NUMBER	REVISION	DESCRIPTION	FEED TYPE
2-2266354-1	B	FINE CRIMP HEIGHT ADJUST	MECHANICAL
2-2266354-2	B	FINE CRIMP HEIGHT ADJUST	PNEUMATIC
7-2266354-7	A	CRIMP TOOLING KIT	-

PACIFIC VERSION TERMINATOR  
INTERFACE ADAPTER



APPLICATOR DATA		
CRIMP	SIZE	TYPE
WIRE	1.40 mm [.055]	F
INSUL	2.79 mm [.110]	O

APPLICATOR INSTRUCTIONS  
408-35042

TERMINAL DATA: KOSTAL TERMINAL KOSTAL CRIMP SPECIFICATION

TERMINAL NAME: KOSTAL RECEPTACLE SWS MLK1.2

WIRE STRIP LENGTH	INSULATION DIAMETER RANGE
3.10-3.60 mm [1.22-.142 IN]	∅1.10-1.70 mm [0.43-.067 IN]

TERMINAL APPLICATION SPECIFICATION DOC00061540 Rev A

TERMINALS APPLIED

TE TERMINAL	KOSTAL TERMINAL	TE SEAL	KOSTAL SEAL	SEAL INSULATION DIAMETER RANGE
1572458-1	22140614110	1949520-1	10800507250	∅1.10-1.70
1572458-2	22124614110	1572751-1	10800444521	
1572458-3	22125614110			
2113493-1	32124680640			
2113493-2	32125680640			
2113493-3	32140680640			
286939-1	22140492680			
286939-2	22124492680			
286939-3	22125492680			

WIRE SIZE	CRIMP HEIGHT mm [INCH]	CRIMP HEIGHT REFERENCE SETTING
0.50mm <sup>2</sup>	0.90 +/- 0.03 [.035 +/- .001]	5.2
0.35mm <sup>2</sup>	0.80 +/- 0.03 [.031 +/- .001]	6.3
0.22mm <sup>2</sup> or 0.25mm <sup>2</sup>	0.75 +/- 0.03 [.030 +/- .001]	6.9

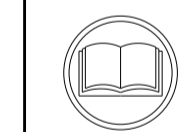

- RECOMMENDED SPARE PARTS
  - REFER TO SUPPLIED INSTRUCTION SHEET FOR CLEANING, LUBRICATION AND STORAGE OF APPLICATOR.
  - APPLY PART NUMBER 2-23419-6 LOCTITE TO THREADS OF ITEM 242.
  - CRIMP HEIGHT REFERENCE SETTING WAS THE SETTING USED WHEN THE APPLICATOR WAS QUALIFIED AT THE FACTORY. ADJUSTMENT MAY BE NECESSARY WHEN RUNNING APPLICATOR IN THE FIELD.
  - CUT TO LENGTH AT ASSEMBLY
6. UNLESS SPECIFIED OTHERWISE TORQUE VALUES SHALL BE USED PER DOCUMENT, 101-35000.

**\*WARNING**  
ON INSTALLATION, SET WIRE DISC TO CRIMP HEIGHT REFERENCE SETTING FOR LARGEST WIRE SIZE. CRIMP HEIGHT REFERENCE SETTINGS GREATER THAN THE VALUE SHOWN MAY CAUSE DAMAGE TO THE CRIMP TOOLING, REFER TO THE INSTRUCTION SHEET FOR PROPER SETUP AND ADJUSTMENTS.

PACIFIC VERSION  
Shown on sheets 3 of 4 & 4 of 4  
(Atlantic version shown on sheets 1 of 4 & 2 of 4)

LOC	DIST	REV	DATE	BY	APPV
A	66				

REV	DATE	DESCRIPTION	ITEM NO			
-	1	1	2119082-4	CAM, SNAIL, INSULATION ADJUSTMENT	244	
-	1	1	2079764-1	WASHER, WAVE SPRING, CREST-TO-CREST	243	
3	-	1	1	2119083-1	RETAINER, INSULATION DIAL	242
-	1	1	7-18023-7	SCR, SKT HD CAP M3 X 4.0	241	
-	-	1	1	2119580-1	MECHANICAL FEED ASSEMBLY	239
-	1	-	2844940-1	AIR FEED MODULE	238	
-	REF	REF	994970-2	COUNTER, MAGNETIC	164	
-	1	-	2119641-2	FEED CAM, AIR FEED	151	
-	1	1	2168083-8	SCR, SKT HD CAP, RoHS, M4 X 16	144	
-	4	4	2168083-9	SCR, SKT HD CAP, RoHS, M4 X 20	143	
-	-	1	1	2119653-2	FEED CAM, POST FEED	142
-	1	1	1-1803583-0	APPLICATOR BASIC ASSEMBLY, SF	141	
-	1	1	1803516-1	RAM ASSEMBLY, SF PACIFIC	140	
-	1	1	2844908-1	SCREW, LOCKING	99	
-	1	1	2844907-1	POST, LOCKING	98	
-	1	1	455888-6	SPACER, CRIMPER	82	
-	1	1	1803607-3	DOCUMENTATION PACKAGE	71	
-	1	1	2119740-1	TAG, IDENTIFICATION	67	
-	2	2	2168078-1	SCREW, DRIVE, RH, RoHS, 2 x .188	66	
-	1	1	5-18022-5	SCR, HEX HD CAP, M4 X 6.0	59	
-	1	1	985575-3	SCR, FLT SKT HD CAP M3 X 10.0	57	
-	1	1	1338683-8	FEED PAWL	56	
3	-	2	2	2168083-8	SCR, SKT HD CAP, RoHS, M4 X 16	53
-	1	1	5018030-1	NUT, HEX, REG, RoHS, M3	52	
-	1	1	811242-5	BUMPER, HOLD DOWN	51	
-	1	1	690753-2	SPACER, TONKER	50	
-	1	2	18023-9	SCR, SKT HD CAP M4 X 6.0	49	
-	-	1	2119652-1	FEED CAM, PRE FEED	48	
-	1	1	1803602-1	SCR, BHSC, RoHS (M8 X 25)	41	
-	1	1	2-1752356-0	SUPPORT, TERMINAL	34	
-	2	2	2079383-5	SCR, BHSC, RoHS (M4 X 20)	33	
-	2	2	2-2844962-8	SPACER, CYLINDRICAL, STRIP GUIDE	30	
-	1	1	2844992-1	ASSEMBLY, STRIP GUIDE	29	
-	1	1	455888-3	SPACER, CRIMPER	28	
-	1	1	1320928-2	STRIP GUIDE	24	
-	1	1	2168083-2	SCR, SKT HD CAP, RoHS, M4 X 8.0	21	
-	2	2	1-18028-2	WASHER, FLAT, REG M4	20	
-	1	1	2119533-1	STRIPPER, SIDE FEED	19	
1	-	1	1	2119806-1	INSERT, SHEAR	13
-	1	1	3-22280-3	SPRING, COMPRESSION	12	
-	1	1	1-356885-4	STOP, SHEAR	11	
1	-	1	1	2119805-1	SHEAR HOLDER, FRONT	10
1	-	1	1	318707-1	FLOATING SHEAR, FRONT	9
1	1	1	1	8-1333201-1	ANVIL, COMBINATION	8
-	1	1	1	1-240641-6	SPACER	7
-	-	-	-	-	6	
-	1	1	2-2119781-4	DEPRESSOR, SHEAR	5	
-	1	1	3-238011-8	BLOCK, CRIMPER SPACER	4	
1	1	1	1	6-1633965-3	CRIMPER, INSULATION O PREMIUM	3
-	1	1	1	455888-9	SPACER, CRIMPER	2
1	1	1	1	4-456402-5	CRIMPER, WIRE PREMIUM	1

DIMENSIONS:		TOLERANCES UNLESS OTHERWISE SPECIFIED:		MATERIAL:		FINISH:	
mm	0 PLC ±	1 PLC ±	2 PLC ±	3 PLC ±	4 PLC ±	ANGLES ±	

DATE	12MAR2014	BY	B. WEAVER
CHK	12MAR2014	BY	G. BAILEY
APPV	12MAR2014	BY	G. BAILEY

NAME	Ocean Side Feed Applicator		
SIZE	CAGE CODE	DRAWING NO	RESTRICTED TO
A1	00779	2266354	

CUSTOMER DRAWING SCALE 1:2 SHEET 3 OF 4 REV B

LOC	DIST	REV	DATE	BY	APPD
A	66				

# FEED TYPE MECHANICAL

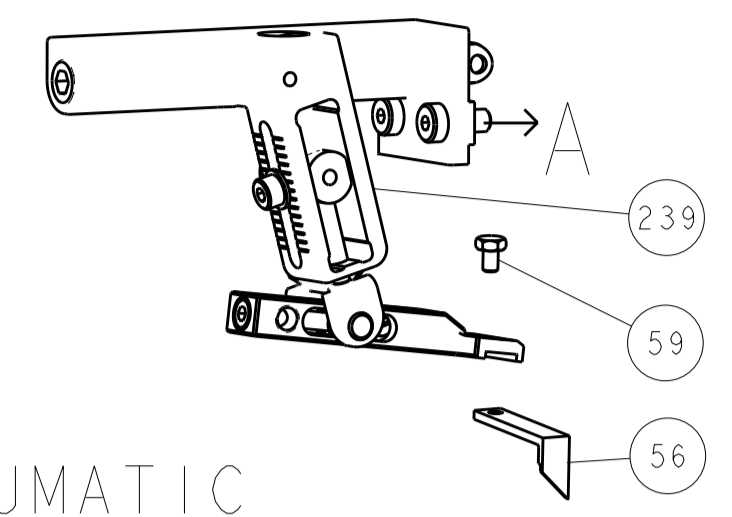

## PNEUMATIC

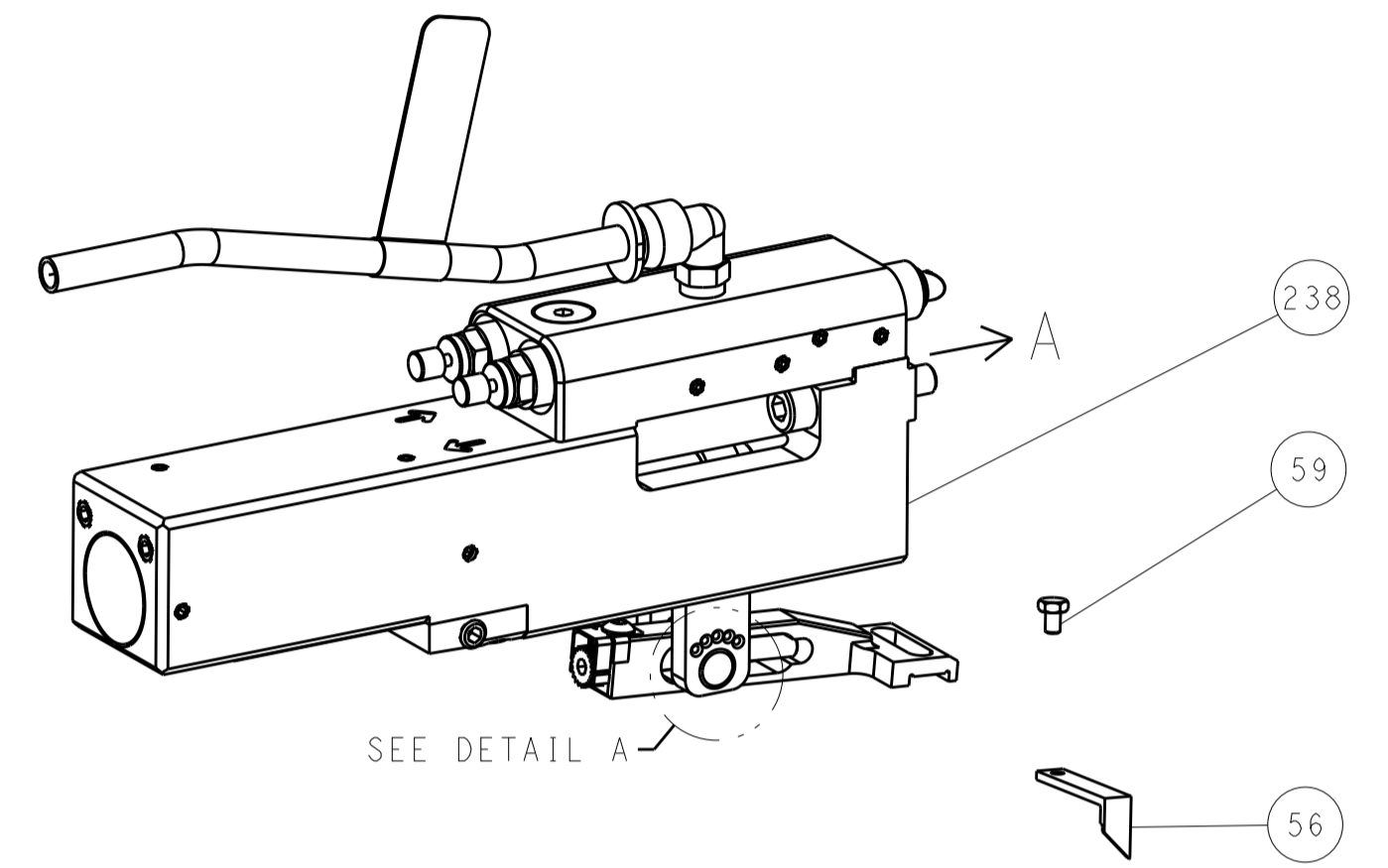

## FEED SPRING SETTING POSITION (SHOWN FROM REAR SIDE)

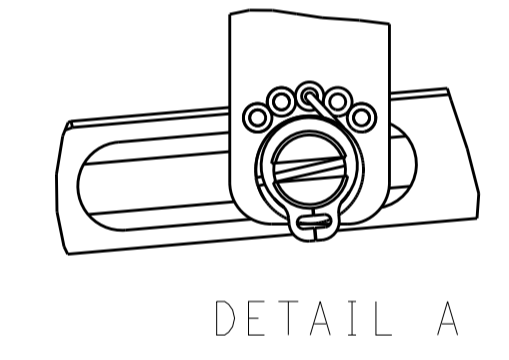

# CAM POSITIONS

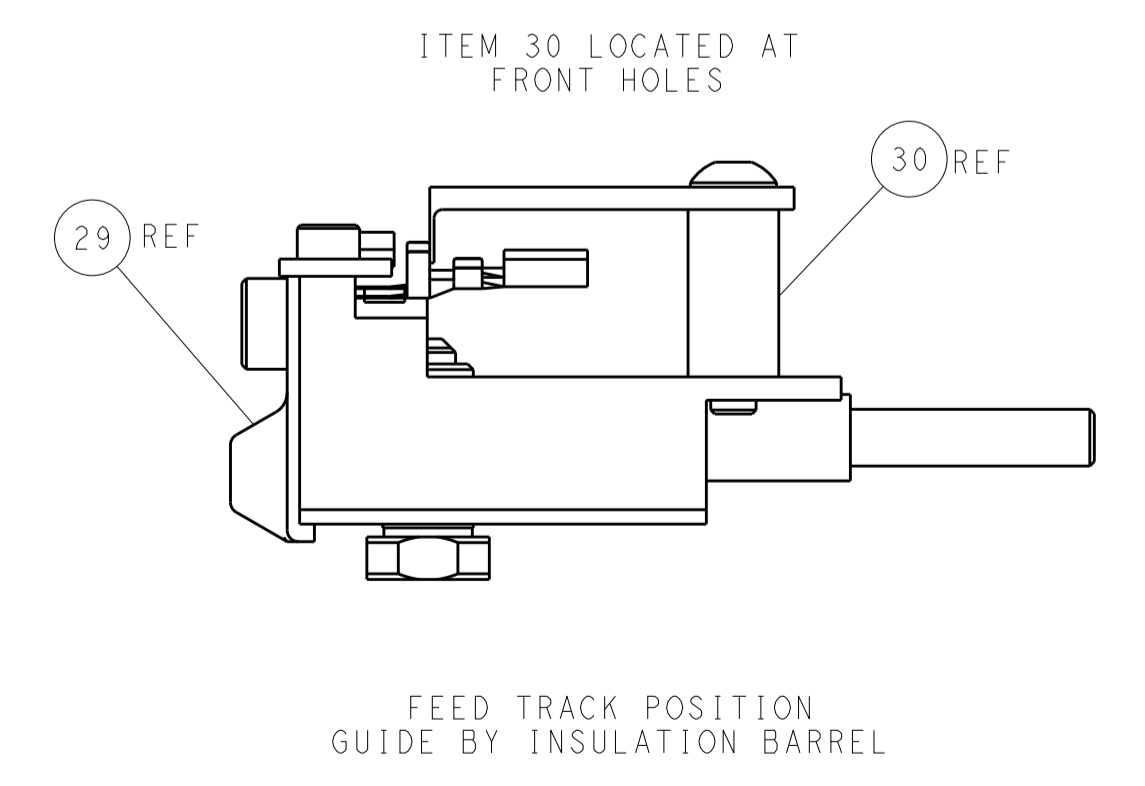
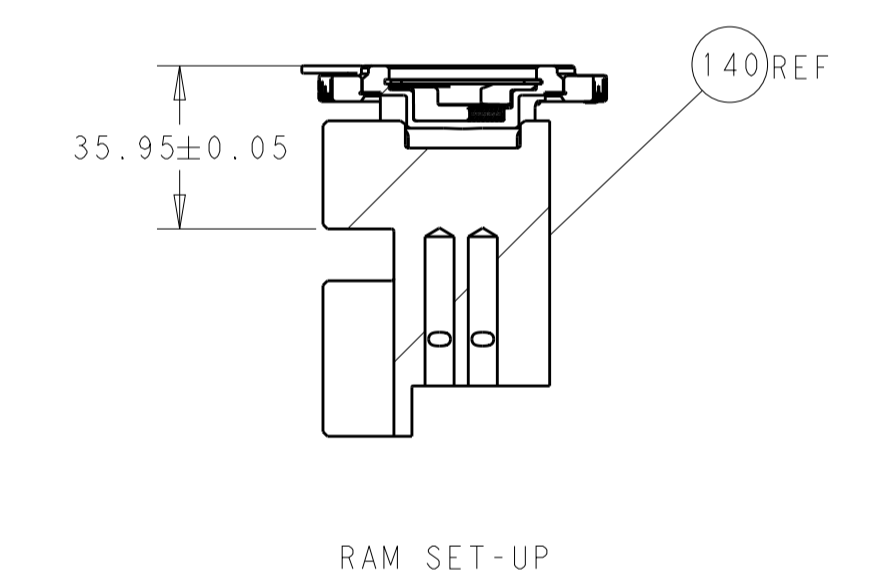
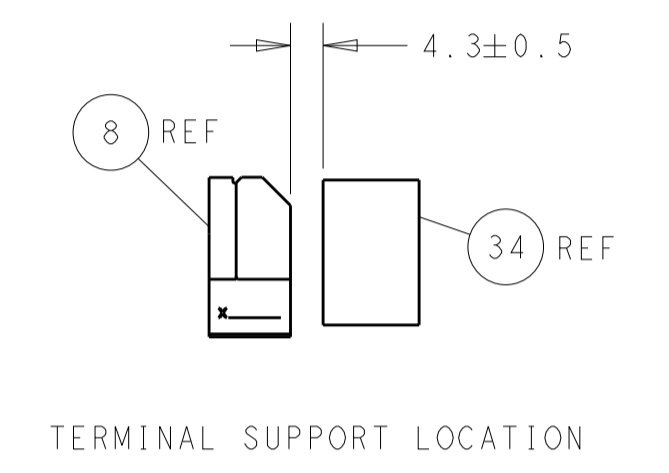
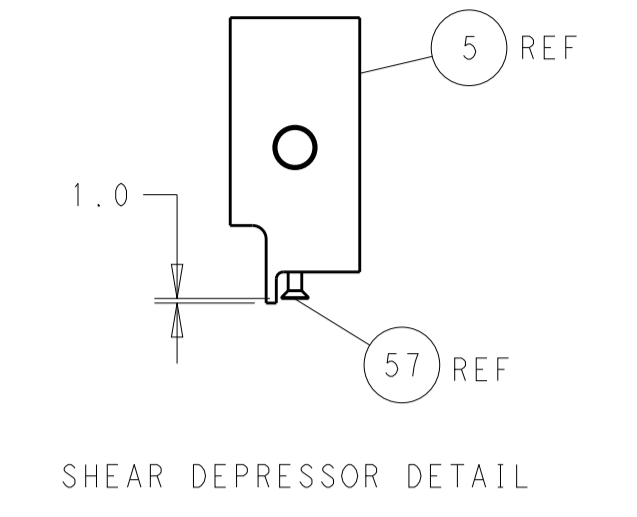
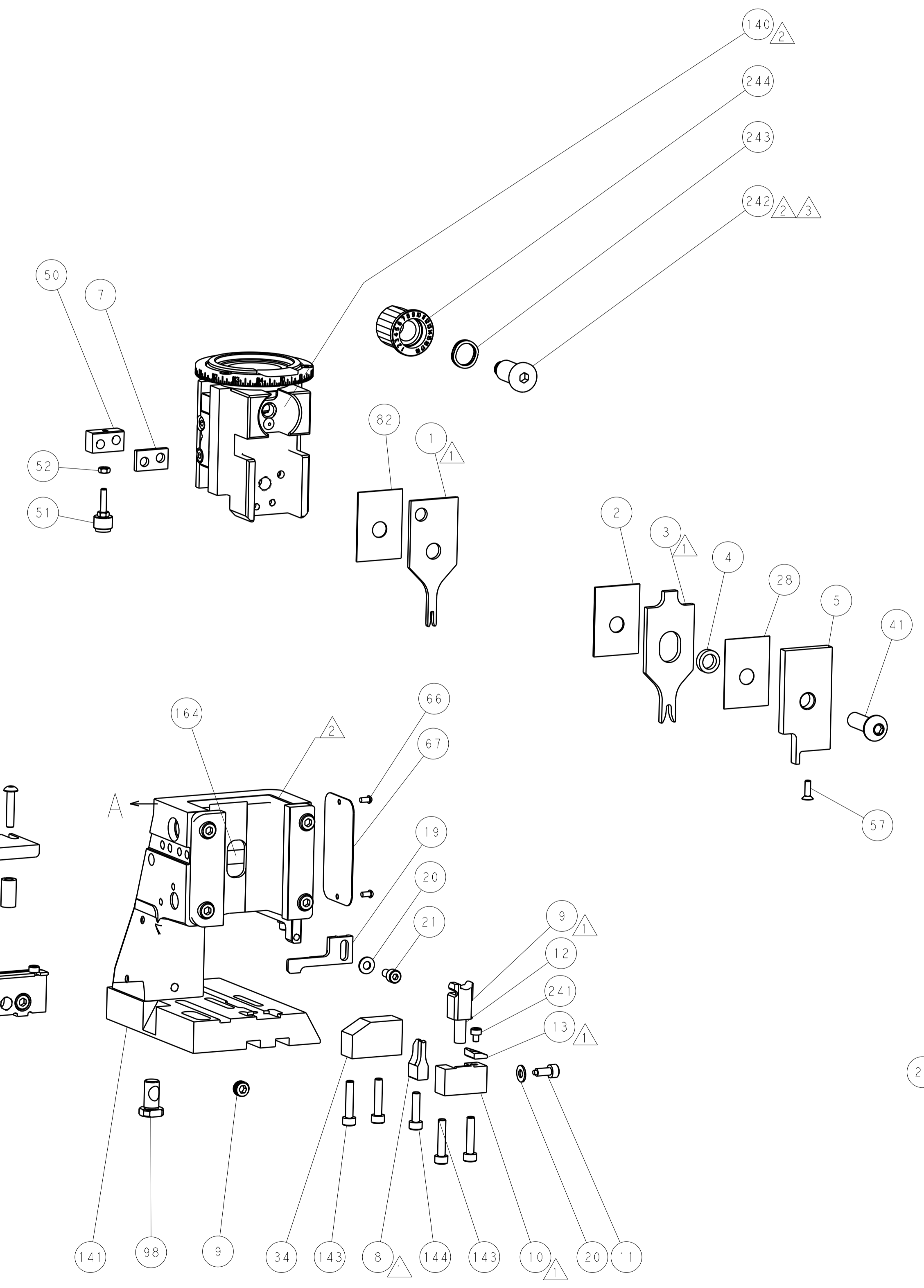

**PACIFIC VERSION**  
 Shown on sheets 3 of 4 & 4 of 4  
 (Atlantic version shown on sheets 1 of 4 & 2 of 4)

DIMENSIONS:		TOLERANCES UNLESS OTHERWISE SPECIFIED:		DWG: B. WEAVER 12MAR2014		TE Connectivity	
mm	0 PLC ±	1 PLC ±	2 PLC ±	3 PLC ±	4 PLC ±	5 PLC ±	Harrisburg, PA 17105-3608
	ANGLES	FINISH		CHK: G. BAILEY 12MAR2014		NAME: Ocean Side Feed Applicator	
MATERIAL:				APVD: G. BAILEY 12MAR2014		PRODUCT SPEC:	
				APPLICATION SPEC:		SIZE: CAGE CODE: DRAWING NO:	
				WEIGHT:		RESTRICTED TO:	
				CUSTOMER DRAWING:		A1 00779 ©=2266354	
				SCALE: 1:2		SHEET 4 OF 4 REV B	