



From IoT idea to proof-of-concept as easy as 1-2-3

Rapid IoT Prototyping Kit: SLN-RPK-NODE

OVERVIEW:

Rapid IoT combines optimized **hardware** design including processing, connectivity and trusted security with proven **software** including drivers, middleware and GUI based programming enabling anyone to easily take their IoT idea to a proof of concept (POC).

Rapid IoT accelerates the 3 phases of a typical POC development. Pre-programmed applications enable a user to get up and running quickly and 'play' or get familiar with its capabilities. Next, the Web IDE with GUI based programming means anyone can 'tinker' or modify the device's behavior without having to program in C. Finally, production-proven MCUXpresso tools provide a path to validate code and 'develop' new applications.

TARGET APPLICATIONS

- ▶ Internet of Things (IoT)
 - Smart home/ building
 - Smart cities
 - Industrial
 - Smart Appliances
 - Unmanned vehicles: Rovers/ UAVs
 - Applications yet to be discovered
- ▶ Designs needing small form factor, low power and low cost
- ▶ Users range from experienced engineers to makers

IoT PROTOTYPE DEVELOPMENT

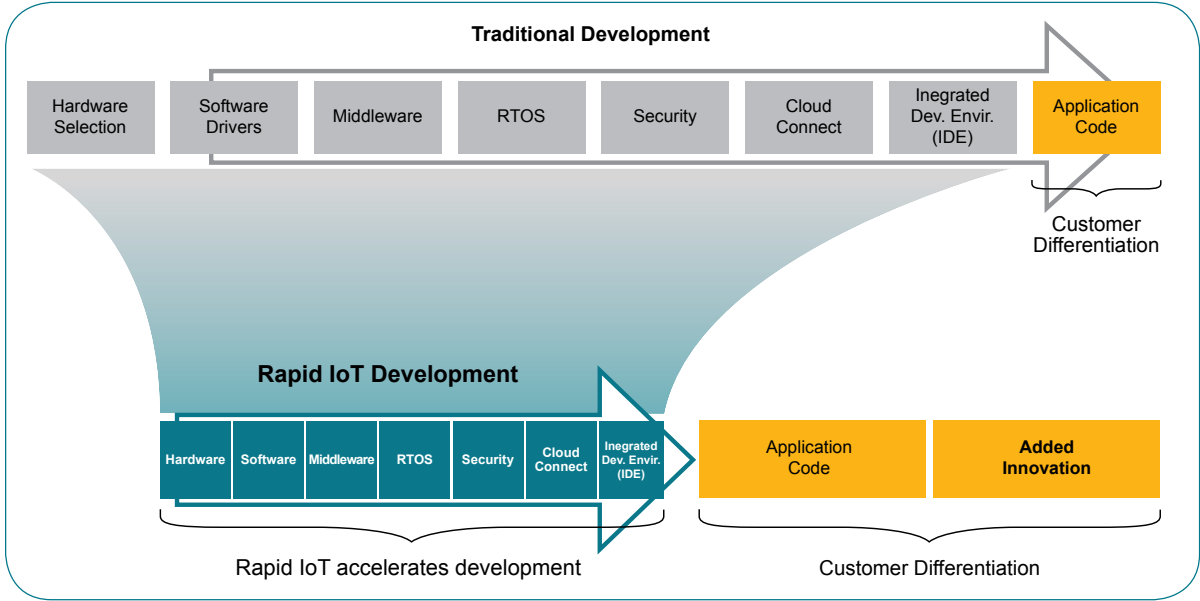

FEATURES AND BENEFITS

Comprehensive, pre-engineered IoT node

- ▶ Kinetis® K64F Arm® Cortex®-M4 MCU for application processing
- ▶ KW41Z Wireless MCU: BLE, Thread, Zigbee allows connection to a gateway or cloud
- ▶ Optimized for low-power and small form factor

Enhanced Security

- ▶ A1006 Secure Authentication & anti-counterfeit IC
- ▶ NT3H2211 NFC Forum Type2 Tag

Extreme ease-of-use for rapid prototyping

- ▶ Web IDE with GUI based programming (no C needed) enables anyone to jump-start their IoT design
- ▶ Software enablement: RTOS, drivers, middleware, iOS/ Android mobile apps & Cloud connect eases the transition from prototype to development

CONNECTIVITY OPTIONS

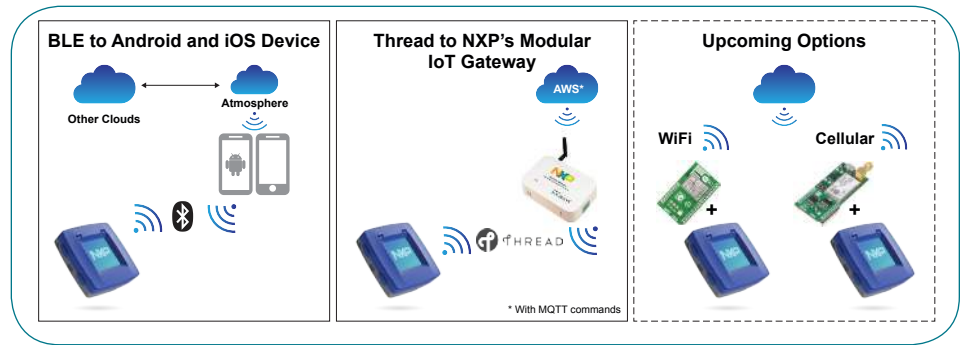

Flexible, scalable

- ▶ Multiple sensor options include Gyroscope, Acc/ Mag., Barometer/ Temp., Air Quality, Ambient light and capacitive touch etc.
- ▶ Easy expandability to most IoT end node use cases with 400+ Click boards™

ECOSYSTEM AND ENABLEMENT

- ▶ Pre-installed software applications:
 - Weather station incl. Air quality monitor

- Thermostat
- Tilt/ Fall detection
- Low-power motion detection
- Tap converter
- RGB LED and more
- ▶ Uses Atmosphere Web IDE to generate projects and source code for the MCUXpresso IDE
- ▶ Docking station for debug and adding Click boards™
- ▶ Optional NXP IoT Modular Gateway

Rapid IoT BLOCK DIAGRAM

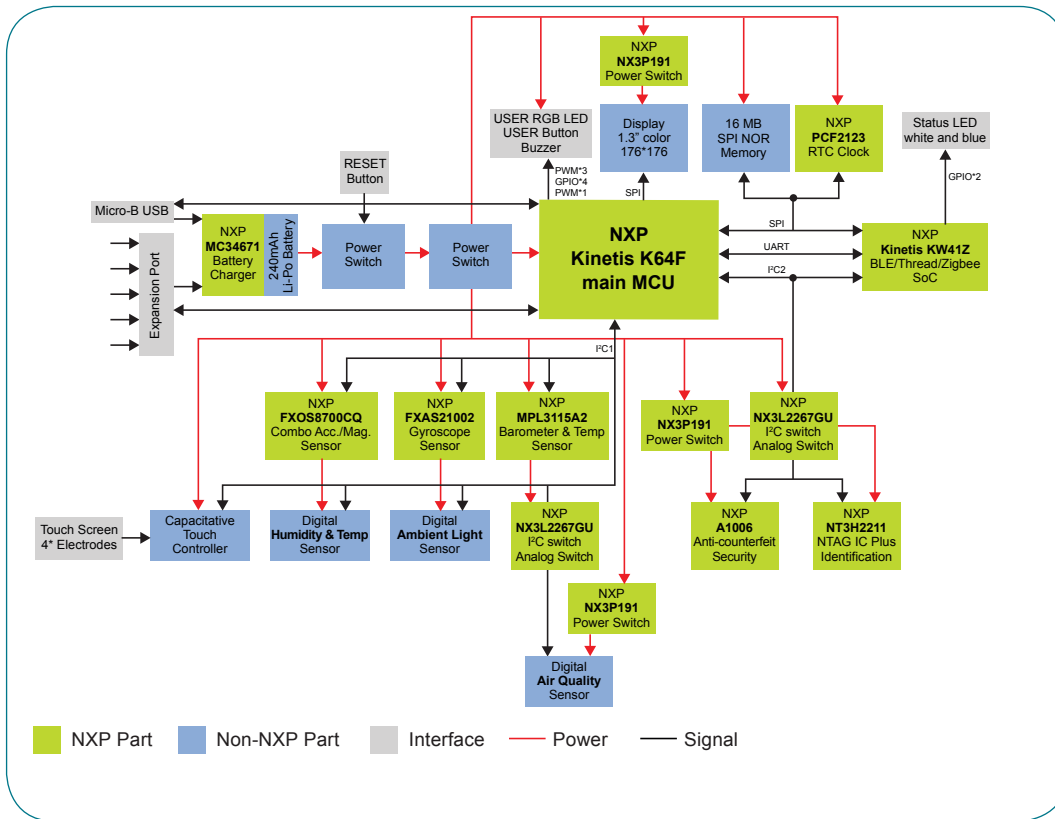

SOFTWARE AND TOOLS

Atmosphere

- ▶ IDE, GUI-based programming blocks

MCUXpresso

- ▶ IDE, SDK, Configuration Tools