

Quad Sine-Wave Clock Buffer Evaluation Board

Contents

1	General Description	2
1.1	Features	2
2	Signal Path and Control Circuitry	2
3	Getting Started	3
4	Power-Supply Connections	3
5	Output Clock	3
6	Enabling/Disabling Outputs	3
7	Bill of Materials	4
8	Schematic	6

List of Figures

1	CDC3S04 Evaluation Board	2
2	Schematic – (1 of 3)	6
3	Schematic – (2 of 3)	7
4	Schematic – (3 of 3)	8

List of Tables

1	Clock Source	3
2	Supply source	3
3	Outputs on the CDC3S04EVM	3
4	Jumpers to Control the CDC3S04	3
5	Bill of Materials	4

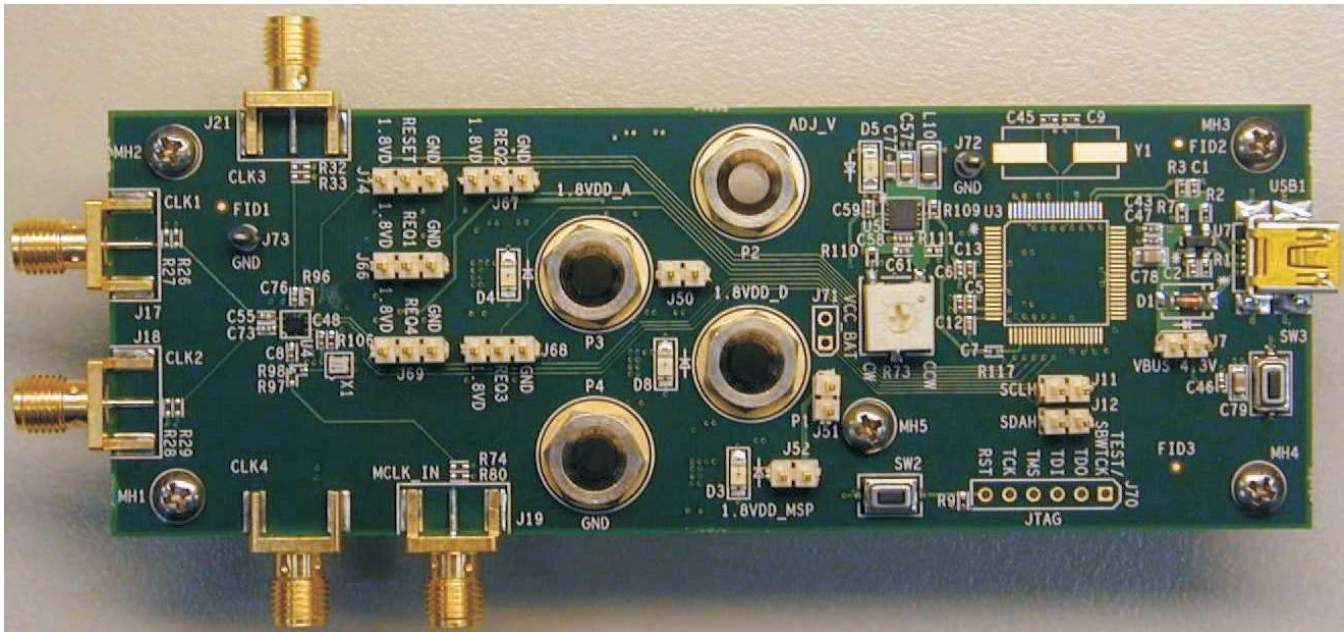

Figure 1. CDC3S04 Evaluation Board

1 General Description

The CDC3S04 is a four-channel low-power sine-wave clock buffer. It can be used to buffer a single master clock to multiple peripherals. The four sine-wave outputs (CLK1–CLK4) are designed for minimal channel-to-channel skew and ultralow additive output jitter. Each output has its own clock request input which enables the dedicated clock output. These clock requests are active-high (can also be changed to be active-low via I2C™), and an output signal is generated that can be sent back to the master clock to request the clock (MCLK_REQ). MCLK_REQ is an open-source output and supports the wired-OR function (default mode). It needs an external pulldown resistor. MCLK_REQ can be changed to wired-AND or push-pull functionality via I2C.

This evaluation module (EVM) is designed to demonstrate the electrical performance of the CDC3S04. Throughout this document, the acronym EVM and the phrases evaluation module and evaluation board are synonymous with the CDC3S04 EVM. Figure 1 illustrates the CDC3S04 EVM.

For optimum performance, the board is equipped with 50Ω SMA connectors and well controlled 50Ω impedance microstrip transmission lines.

1.1 Features

- Easy-to-use evaluation board to fan out low phase noise
- Easy device setup
- Control pins configurable through jumpers
- Board powered using USB or external supply

2 Signal Path and Control Circuitry

The CDC3S04 EVM has a TCXO soldered. If the customer wants to try out a different source then the EVM allows routing the external signal to the CDC3S04. Resistors must be solder or desolder. See [Table 1](#) for each configuration.

Table 1. Clock Source

Component	TCXO on board	External input
R80	Not mounted	Not mounted
R74	Not mounted	Not mounted
R98	0R0	Not mounted
R97	Not mounted	0R0
C8	15 pF	15 pF

3 Getting Started

The CDC3S04EVM has self-explanatory labeling and uses similar naming conventions as the CDC3S04 product data sheet ([SCAS883](#)). In this user's guide, all words in **boldface and italic print** reflect the actual labeling on the EVM.

4 Power-Supply Connections

The CDC3S04EVM has three pins that require external supply. Those pins are VDD_ANA, VDD_DIG and VBAT. These supplies can come from the USB or using an external power supply. See [Table 2](#) for further information.

Table 2. Supply source

USB	External Power Supply
R113 = 0R0	J50 OFF
R112 = Not mounted	J51 OFF
J50 ON	P3 = VDD_ANA
J51 ON	P1 = VDD_DIG

Also the CDC3S04 has an LDO build in that generates the supply for the TCXO. This voltage can be generated using the TPS71219 on board or the P2 connector.

5 Output Clock

The outputs of the CDC3S04 are available on any of the SMA connectors

Table 3. Outputs on the CDC3S04EVM

SMA	Output
J17	CLK1
J68	CLK2
J21	CLK3
J20	CLK4

6 Enabling/Disabling Outputs

The CDC3S04EVM has several jumpers that can control the output enable of the CDC3S04.

Table 4. Jumpers to Control the CDC3S04

Jumper	Function
J66	REQ1
J67	REQ2
J68	REQ3
J69	REQ4
J74	RESET

7 Bill of Materials
Table 5. Bill of Materials

QTY	Value	Designator	PKG/CASE	Manufacturer	Lot Number
10	0.01uF	C8, C12, C13, C33, C35, C53, C58, C63, C67, C71	0402	Venkel	C0402X7R500-103KNE
15	0.1uF	C4, C5, C6, C16, C34, C36, C49, C54, C64, C68, C72, C55, C73, C75, C76	0402	Venkel	C0402X7R160-104KNE
2	0.22uF	C3, C74	0402	Venkel	C0402X5R6R3-224KNE
1	0.47uF	C7	0402	Murata Electronics North Am	GRM155R61A474KE15D
5	1.0uF	C51, C62, C66, C70, C48	0402	Murata Electronics North Am	GRM155R61A105KE15D
5	10pF	C1, C2, C43, C46, C47	0402	Venkel	C0402COG500-100JNE
3	15pF	C31, C32, C61	0402	Venkel	C0402COG500-150JNE
2	2.2iF	C59, C60	0402	Murata Electronics North Am	GRM155R60J225ME15D
1	10000pF	C14	0603	Tdk Corporation	C1608X7R1H103K
1	10iF	C77	0603	Panasonic	ECJ-1VB0J106M
1	0.1iF	C57	0805	Kemet	C0805C104J5RACTU
10	4.7iF	C41, C42, C44, C50, C52, C56, C65, C69, C78, C79	0805	Venkel	C0805X5R250-475KNE
2	10iF	C11, C15	3216-18 (EIA)	Kemet	B45196H3106K109
1	100K	R73	7.04 x 6.71 x 4.8	Bourns Inc.	3361P-1-104GLF
7	0R0	R98, R106, R108, R112, R113, R114, R115	0402	Panasonic - Ecg	ERJ-2GE0R00X
2	1.00K	R124, R125	0402	Venkel	CR0402-16W-1001FT
1	1.00M	R7	0402	Venkel	CR0402-16W-1004FT
1	1.40K	R3	0402	Panasonic - Ecg	ERJ-2RKF1401X
3	10	R70, R75, R77	0402	Venkel	CR0402-16W-10R0FT
12	10.0K	R79, R94, R95, R99, R100, R101, R102, R103, R104, R109, R116, R123	0402	Rohm	MCR01MZPF1002
1	100K	R8	0402	Yageo America	RC0402FR-07100KL
7	22.1	R107, R117, R118, R119, R120, R121, R122	0402	Panasonic - Ecg	ERJ-2RKF22R1X
1	3.32K	R78	0402	Panasonic - Ecg	ERJ-2RKF3321X
1	30.1K	R111	0402	Venkel	CR0402-16W-3012FT
1	31.6K	R110	0402	Panasonic - Ecg	ERJ-2RKF3162X
2	33.2	R1, R2	0402	Venkel	CR0402-16W-33R2FT
1	33.2K	R105	0402	Panasonic - Ecg	ERJ-2RKF3322X
1	332	R76	0402	Vishay/Dale	CRCW0402332RFKED
1	47.5K	R9	0402	Venkel	CR0402-16W-4752FT
1	5.1K	R96	0402	Venkel	CR0402-16W-5101FT
2	5.62K	R5, R6	0402	Venkel	CR0402-16W-5621FT
1	USB - Mini AB type	USB1	SMT	Jae Electronics	DX3R005HN2E700
1	38.4MHz	X1	4-SMT	KDS	1XXD38400CAA
1	TPD2E001DZDR	U7	4-SOP	Texas Instruments	TPD2E001DZDR
1	LLSD103A-7	D1	Mini MELF	Diodes Inc	LLSD103A-7
5	50	L6, L7, L8, L9, L10	1206	Murata Electronics North Am	BLM31PG500SN1L
1	TPS71219DRCT	U5	10-SON	Texas Instruments	TPS71219DRCT
1	CDC3S04YFFR	U4	20-DSBGA	Texas Instruments	CDC3S04YFFR
3	LED - Green Clear	D3, D4, D8	1206	Lite-On	LTST-C150KGKT
1	LED - Red Clear	D5	1206 (3216)	Cml Innovative Technologies	CMD15-21VRC/TR8
2	PTS635SL25SMTR LFS	SW2, SW3	6mm x 3.50mm	C&K Components	PTS635SL25SMTR LFS
5	142-0701-801	J17, J18, J19, J20, J21	RF SMA EDGE	Emerson Network Power Co	142-0701-801
2	Test Loop - Black	J72, J73	0.1"	Components Corporation	TP-105-40-00
6	1 X 2	J7, J11, J12, J50, J51, J52	0.1"	HTSW-150-08-G-S	K10000012278

Table 5. Bill of Materials (continued)

5	1 X 3	J66, J67, J68, J69, J74	0.1"	HTSW-150-08-G-S	K10000012278
4	Banana Plug - Metal	P1, P2, P3, P4	4mm	Emerson Network Power Co	108-0740-001
5	4-40/0.25"- Screws	MH1, MH2, MH3, MH4, MH5		Building Fasteners	PMSSS 440 0025 PH
5	0.75"	MH1, MH2, MH3, MH4, MH5			
14	DNI	C9, C10, R26, R27, R28, R29, R30, R31, R32, R33, C45, R74, R80, R97			
2	DNI	J70, J71			
1	DNI	U3			
1	DNI	Y1			

8 Schematic

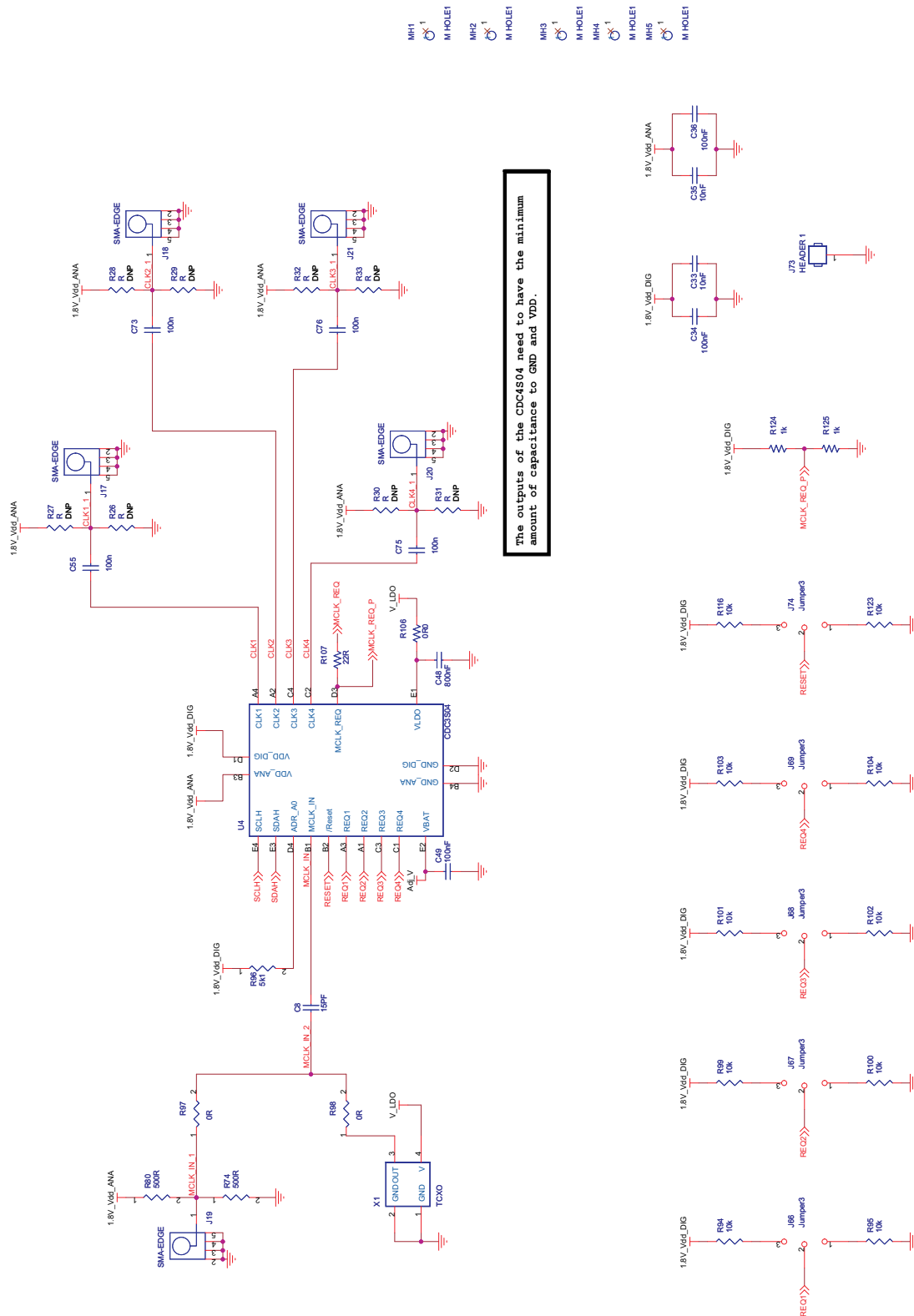

Figure 2. Schematic – (1 of 3)

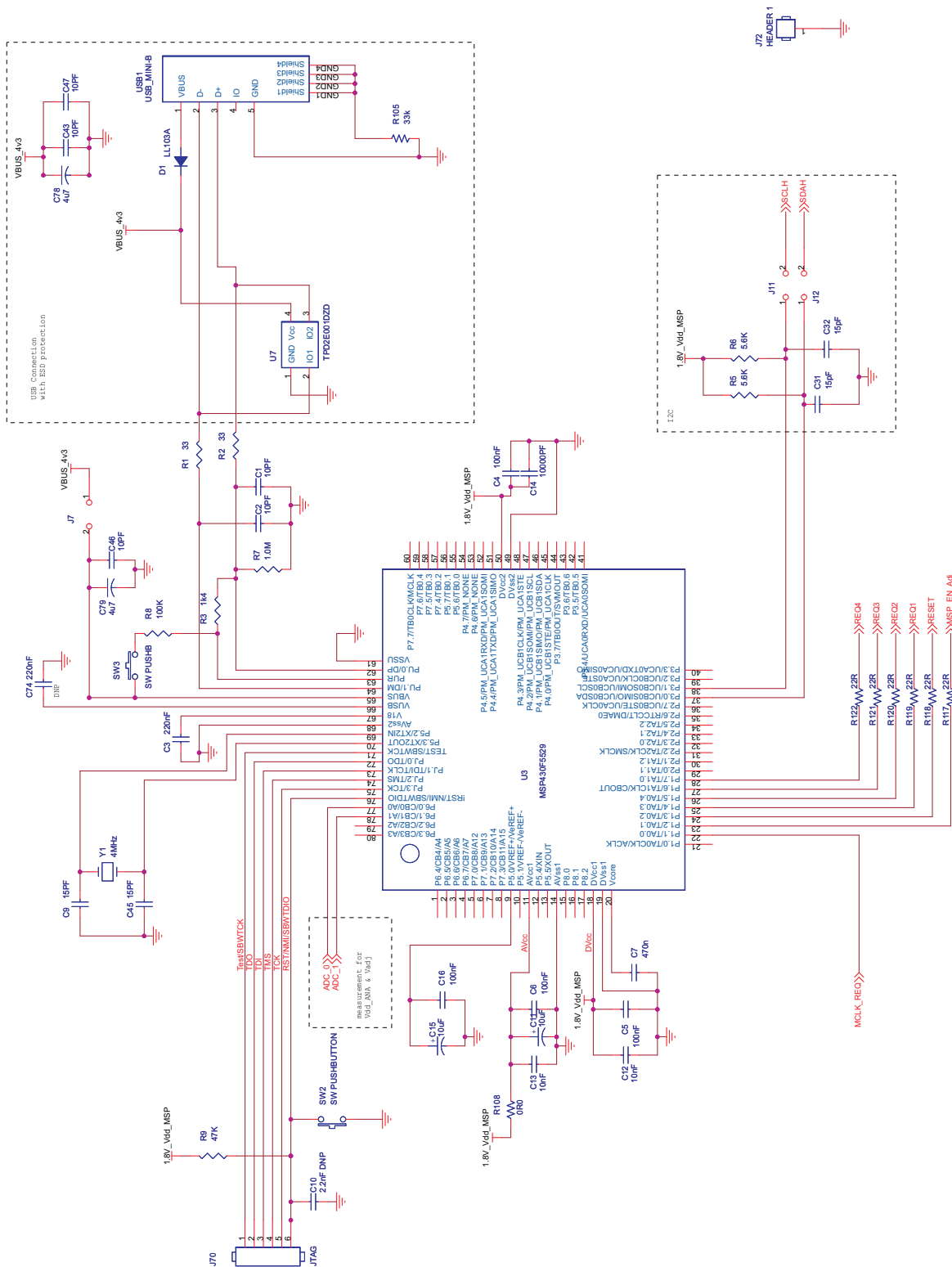

Figure 3. Schematic – (2 of 3)

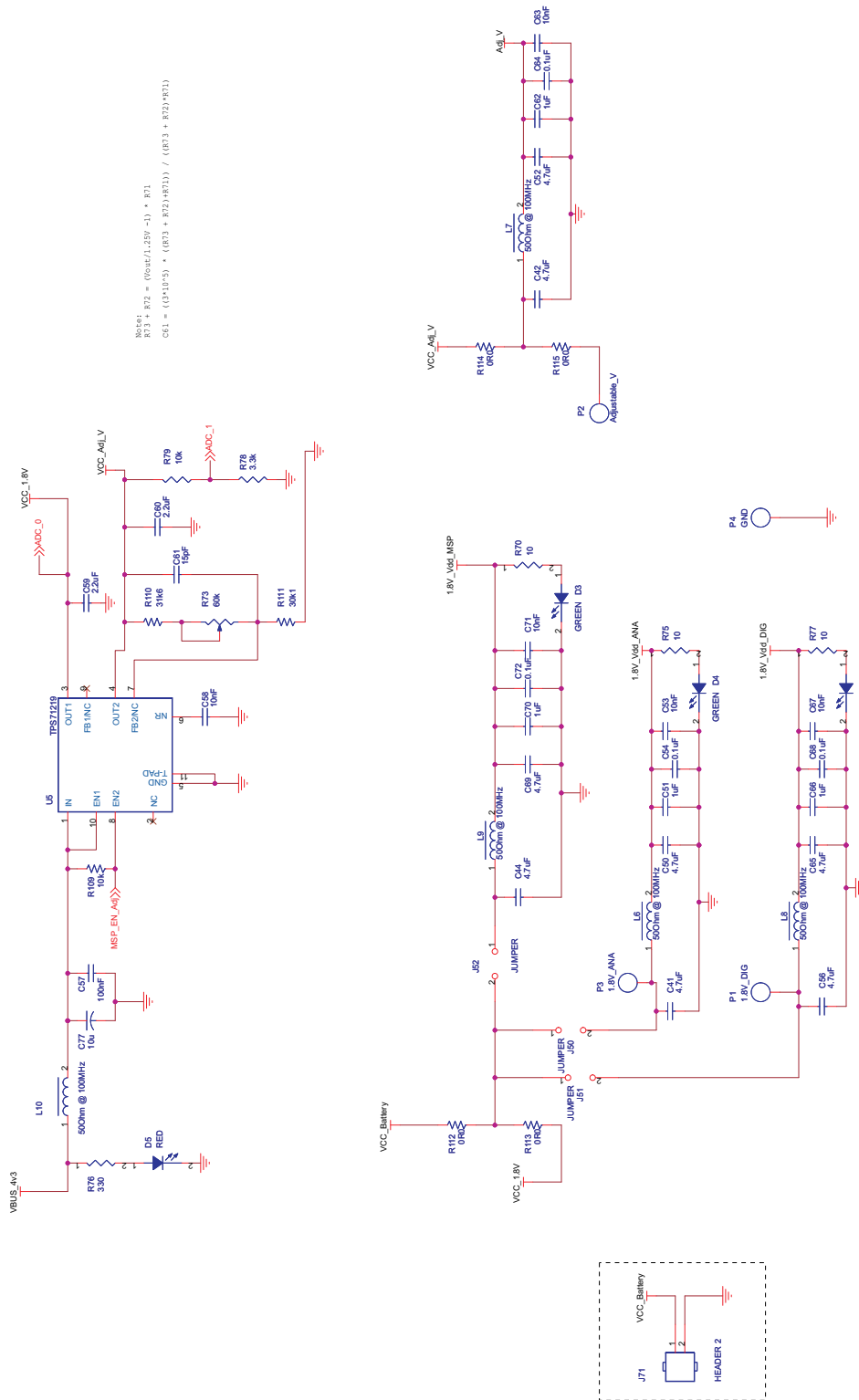

Figure 4. Schematic – (3 of 3)

Evaluation Board/Kit Important Notice

Texas Instruments (TI) provides the enclosed product(s) under the following conditions:

This evaluation board/kit is intended for use for **ENGINEERING DEVELOPMENT, DEMONSTRATION, OR EVALUATION PURPOSES ONLY** and is not considered by TI to be a finished end-product fit for general consumer use. Persons handling the product(s) must have electronics training and observe good engineering practice standards. As such, the goods being provided are not intended to be complete in terms of required design-, marketing-, and/or manufacturing-related protective considerations, including product safety and environmental measures typically found in end products that incorporate such semiconductor components or circuit boards. This evaluation board/kit does not fall within the scope of the European Union directives regarding electromagnetic compatibility, restricted substances (RoHS), recycling (WEEE), FCC, CE or UL, and therefore may not meet the technical requirements of these directives or other related directives.

Should this evaluation board/kit not meet the specifications indicated in the User's Guide, the board/kit may be returned within 30 days from the date of delivery for a full refund. **THE FOREGOING WARRANTY IS THE EXCLUSIVE WARRANTY MADE BY SELLER TO BUYER AND IS IN LIEU OF ALL OTHER WARRANTIES, EXPRESSED, IMPLIED, OR STATUTORY, INCLUDING ANY WARRANTY OF MERCHANTABILITY OR FITNESS FOR ANY PARTICULAR PURPOSE.**

The user assumes all responsibility and liability for proper and safe handling of the goods. Further, the user indemnifies TI from all claims arising from the handling or use of the goods. Due to the open construction of the product, it is the user's responsibility to take any and all appropriate precautions with regard to electrostatic discharge.

EXCEPT TO THE EXTENT OF THE INDEMNITY SET FORTH ABOVE, NEITHER PARTY SHALL BE LIABLE TO THE OTHER FOR ANY INDIRECT, SPECIAL, INCIDENTAL, OR CONSEQUENTIAL DAMAGES.

TI currently deals with a variety of customers for products, and therefore our arrangement with the user **is not exclusive.**

TI assumes **no liability for applications assistance, customer product design, software performance, or infringement of patents or services described herein.**

Please read the User's Guide and, specifically, the Warnings and Restrictions notice in the User's Guide prior to handling the product. This notice contains important safety information about temperatures and voltages. For additional information on TI's environmental and/or safety programs, please contact the TI application engineer or visit www.ti.com/esh.

No license is granted under any patent right or other intellectual property right of TI covering or relating to any machine, process, or combination in which such TI products or services might be or are used.

FCC Warning

This evaluation board/kit is intended for use for **ENGINEERING DEVELOPMENT, DEMONSTRATION, OR EVALUATION PURPOSES ONLY** and is not considered by TI to be a finished end-product fit for general consumer use. It generates, uses, and can radiate radio frequency energy and has not been tested for compliance with the limits of computing devices pursuant to part 15 of FCC rules, which are designed to provide reasonable protection against radio frequency interference. Operation of this equipment in other environments may cause interference with radio communications, in which case the user at his own expense will be required to take whatever measures may be required to correct this interference.

EVM Warnings and Restrictions

It is important to operate this EVM within the input voltage range of 2.2 V to 3.6 V and the output voltage range of 2.2 V to 3.6 V .

Exceeding the specified input range may cause unexpected operation and/or irreversible damage to the EVM. If there are questions concerning the input range, please contact a TI field representative prior to connecting the input power.

Applying loads outside of the specified output range may result in unintended operation and/or possible permanent damage to the EVM. Please consult the EVM User's Guide prior to connecting any load to the EVM output. If there is uncertainty as to the load specification, please contact a TI field representative.

During normal operation, some circuit components may have case temperatures greater than 85°C. The EVM is designed to operate properly with certain components above 85°C as long as the input and output ranges are maintained. These components include but are not limited to linear regulators, switching transistors, pass transistors, and current sense resistors. These types of devices can be identified using the EVM schematic located in the EVM User's Guide. When placing measurement probes near these devices during operation, please be aware that these devices may be very warm to the touch.

Mailing Address: Texas Instruments, Post Office Box 655303, Dallas, Texas 75265
Copyright © 2010, Texas Instruments Incorporated

IMPORTANT NOTICE

Texas Instruments Incorporated and its subsidiaries (TI) reserve the right to make corrections, modifications, enhancements, improvements, and other changes to its products and services at any time and to discontinue any product or service without notice. Customers should obtain the latest relevant information before placing orders and should verify that such information is current and complete. All products are sold subject to TI's terms and conditions of sale supplied at the time of order acknowledgment.

TI warrants performance of its hardware products to the specifications applicable at the time of sale in accordance with TI's standard warranty. Testing and other quality control techniques are used to the extent TI deems necessary to support this warranty. Except where mandated by government requirements, testing of all parameters of each product is not necessarily performed.

TI assumes no liability for applications assistance or customer product design. Customers are responsible for their products and applications using TI components. To minimize the risks associated with customer products and applications, customers should provide adequate design and operating safeguards.

TI does not warrant or represent that any license, either express or implied, is granted under any TI patent right, copyright, mask work right, or other TI intellectual property right relating to any combination, machine, or process in which TI products or services are used. Information published by TI regarding third-party products or services does not constitute a license from TI to use such products or services or a warranty or endorsement thereof. Use of such information may require a license from a third party under the patents or other intellectual property of the third party, or a license from TI under the patents or other intellectual property of TI.

Reproduction of TI information in TI data books or data sheets is permissible only if reproduction is without alteration and is accompanied by all associated warranties, conditions, limitations, and notices. Reproduction of this information with alteration is an unfair and deceptive business practice. TI is not responsible or liable for such altered documentation. Information of third parties may be subject to additional restrictions.

Resale of TI products or services with statements different from or beyond the parameters stated by TI for that product or service voids all express and any implied warranties for the associated TI product or service and is an unfair and deceptive business practice. TI is not responsible or liable for any such statements.

TI products are not authorized for use in safety-critical applications (such as life support) where a failure of the TI product would reasonably be expected to cause severe personal injury or death, unless officers of the parties have executed an agreement specifically governing such use. Buyers represent that they have all necessary expertise in the safety and regulatory ramifications of their applications, and acknowledge and agree that they are solely responsible for all legal, regulatory and safety-related requirements concerning their products and any use of TI products in such safety-critical applications, notwithstanding any applications-related information or support that may be provided by TI. Further, Buyers must fully indemnify TI and its representatives against any damages arising out of the use of TI products in such safety-critical applications.

TI products are neither designed nor intended for use in military/aerospace applications or environments unless the TI products are specifically designated by TI as military-grade or "enhanced plastic." Only products designated by TI as military-grade meet military specifications. Buyers acknowledge and agree that any such use of TI products which TI has not designated as military-grade is solely at the Buyer's risk, and that they are solely responsible for compliance with all legal and regulatory requirements in connection with such use.

TI products are neither designed nor intended for use in automotive applications or environments unless the specific TI products are designated by TI as compliant with ISO/TS 16949 requirements. Buyers acknowledge and agree that, if they use any non-designated products in automotive applications, TI will not be responsible for any failure to meet such requirements.

Following are URLs where you can obtain information on other Texas Instruments products and application solutions:

Products		Applications	
Amplifiers	amplifier.ti.com	Audio	www.ti.com/audio
Data Converters	dataconverter.ti.com	Automotive	www.ti.com/automotive
DLP® Products	www.dlp.com	Communications and Telecom	www.ti.com/communications
DSP	dsp.ti.com	Computers and Peripherals	www.ti.com/computers
Clocks and Timers	www.ti.com/clocks	Consumer Electronics	www.ti.com/consumer-apps
Interface	interface.ti.com	Energy	www.ti.com/energy
Logic	logic.ti.com	Industrial	www.ti.com/industrial
Power Mgmt	power.ti.com	Medical	www.ti.com/medical
Microcontrollers	microcontroller.ti.com	Security	www.ti.com/security
RFID	www.ti-rfid.com	Space, Avionics & Defense	www.ti.com/space-avionics-defense
RF/IF and ZigBee® Solutions	www.ti.com/lprf	Video and Imaging	www.ti.com/video
		Wireless	www.ti.com/wireless-apps

Mailing Address: Texas Instruments, Post Office Box 655303, Dallas, Texas 75265
Copyright © 2010, Texas Instruments Incorporated