

Low-Cost Thermal Sensor

Features

- Remote Temperature Measurement Using Embedded Thermal Diodes or Commodity Transistors
- Accurate Remote Sensing: $\pm 3^{\circ}\text{C}$ max., 0°C to 100°C
- Excellent Noise Rejection
- I²C and SMBus 2.0-Compatible Serial Interface
- SMBus Timeout to Prevent Bus Lockup
- Voltage Tolerant I/Os
- Low Power Shutdown Mode
- Failsafe Response to Diode Faults
- 3.0V to 3.6V Power Supply Range
- Available in SOT23-6 Package

Applications

- Desktop, Server, and Notebook Computers
- Set-Top Boxes
- Game Consoles
- Appliances

General Description

The MIC281 is a digital thermal sensor capable of measuring the temperature of a remote PN junction. It is optimized for applications favoring low cost and small size. The remote junction may be an inexpensive commodity transistor, e.g., 2N3906, or an embedded thermal diode such as found in Intel Pentium[®] II/III/IV CPUs, AMD Athlon[®] CPUs, and Xilinx Virtex[®] FPGAs.

The MIC281 is 100% software and hardware backward compatible with the MIC280 and features the same industry-leading noise performance and small size. The advanced integrating A/D converter and analog front-end reduce errors due to noise for maximum accuracy and minimum guardbanding.

A 2-wire SMBus 2.0-compatible serial interface is provided for host communication. The clock and data pins are 5V-tolerant regardless of the value of V_{DD}. They will not clamp the bus lines low even if the device is powered down.

Superior performance, low power, and small size make the MIC281 an excellent choice for cost-sensitive thermal management applications.

Package Type

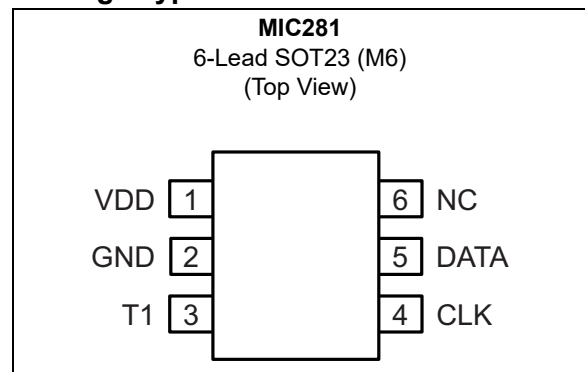

MIC281

Typical Application Circuit

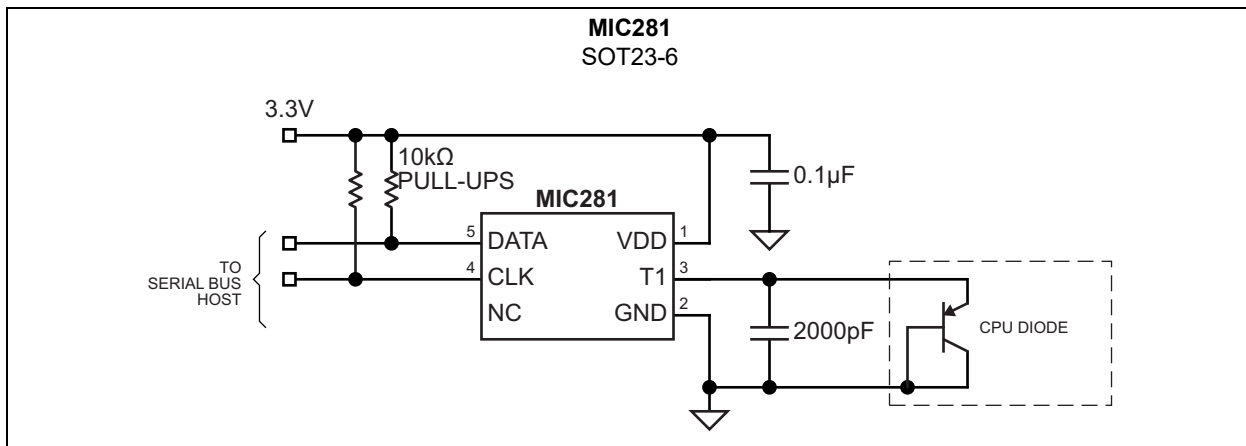

1.0 ELECTRICAL CHARACTERISTICS

Absolute Maximum Ratings †

Power Supply Voltage (V_{DD}).....	+3.8V
Voltage on T1.....	-0.3V to $V_{DD} + 0.3V$
Voltage on CLK, DATA.....	-0.3V to +6V
Current on Any Pin.....	± 10 mA
Power Dissipation ($T_A = +125^\circ\text{C}$).....	109 mW
ESD Rating (HBM, Note 1).....	1.5 kV
ESD Rating (MM, Note 1).....	200V

Operating Ratings ‡

Power Supply Voltage (V_{DD}).....	+3.0V to +3.6V
--	----------------

† Notice: Stresses above those listed under “Absolute Maximum Ratings” may cause permanent damage to the device. This is a stress rating only and functional operation of the device at those or any other conditions above those indicated in the operational sections of this specification is not intended. Exposure to maximum rating conditions for extended periods may affect device reliability.

‡ Notice: The device is not guaranteed to function outside its operating ratings. Final test on outgoing product is performed at $T_A = +25^\circ\text{C}$.

Note 1: Devices are ESD sensitive. Handling precautions are recommended. Human body model, 1.5 k Ω in series with 100 pF.

MIC281

TABLE 1-1: ELECTRICAL CHARACTERISTICS

Electrical Characteristics: $V_{DD} = 3.3V$; $T_A = +25^\circ C$, unless noted. **Bold** values indicate $T_{MIN} \leq T_A \leq T_{MAX}$, unless noted. [Note 1](#)

Parameters	Symbol	Min.	Typ.	Max.	Units	Conditions
Power Supply						
Supply Current	I_{DD}	—	0.23	0.4	mA	T1 open; CLK = DATA = High; Normal mode
		—	9	—	μA	Shutdown mode; T1 open; Note 2 ; CLK = 100 kHz
		—	6	—	μA	Shutdown mode; T1 open; CLK = DATA = High
Power-on Reset Time, Note 2	t_{POR}	—	200	—	μs	$V_{DD} > V_{POR}$
Power-on Reset Voltage	V_{POR}	—	2.65	2.95	V	All registers reset to default values; A/D conversions initiated
Power-on Reset Hysteresis Voltage, Note 2	V_{HYST}	—	300	—	mV	—
Temperature-to-Digital Converter Characteristics						
Accuracy, Note 2 , Note 3 , Note 4	—	—	± 1	± 3	$^\circ C$	$0^\circ C \leq T_D \leq 100^\circ C$, $0^\circ C < T_A < 85^\circ C$; $3.15V < V_{DD} < 3.45V$
		—	± 2	± 5	$^\circ C$	$-40^\circ C \leq T_D \leq 125^\circ C$, $0^\circ C < T_A < 85^\circ C$; $3.15V < V_{DD} < 3.45V$
Conversion Time, Note 2	t_{CONV}	—	200	240	ms	—
Remote Temperature Input, T1						
Current into External Diode, Note 2	I_F	—	192	400	μA	T1 forced to 1.0V, high level
		7	12	—		Low level
Serial Data I/O Pin, DATA						
Low Output Voltage, Note 5	V_{OL}	—	—	0.3	V	$I_{OL} = 3\text{ mA}$
		—	—	0.5		$I_{OL} = 6\text{ mA}$
Low Input Voltage	V_{IL}	—	—	0.8	V	$3V \leq V_{DD} \leq 3.6V$
High Input Voltage	V_{IH}	2.1	—	5.5	V	$3V \leq V_{DD} \leq 3.6V$
Input Capacitance	C_{IN}	—	10	—	pF	Note 2
Input Current	I_{LEAK}	—	—	± 1	μA	—
Serial Clock Input, CLK						
Low Input Voltage	V_{IL}	—	—	0.8	V	$3V \leq V_{DD} \leq 3.6V$
High Input Voltage	V_{IH}	2.1	—	5.5	V	$3V \leq V_{DD} \leq 3.6V$
Input Capacitance	C_{IN}	—	10	—	pF	Note 2
Input Current	I_{LEAK}	—	—	± 1	μA	—
Serial Interface Timing						
CLK (Clock) Period	t_1	2.5	—	—	μs	—
Data-In Set-Up Time to CLK High	t_2	100	—	—	ns	—

TABLE 1-1: ELECTRICAL CHARACTERISTICS (CONTINUED)

Electrical Characteristics: $V_{DD} = 3.3V$; $T_A = +25^{\circ}C$, unless noted. **Bold** values indicate $T_{MIN} \leq T_A \leq T_{MAX}$, unless noted. [Note 1](#)

Parameters	Symbol	Min.	Typ.	Max.	Units	Conditions
Data-Out Stable after CLK Low	t_3	300	—	—	ns	—
Data-Low Set-Up Time to CLK Low	t_4	100	—	—	ns	Start Condition
Data-High Hold Time after CLK High	t_5	100	—	—	ns	Stop Condition
Bus Timeout	t_{TO}	25	30	35	ms	—

- Note 1:** The device is not guaranteed to function outside its operating ratings. Final test on outgoing product is performed at $T_A = +25^{\circ}C$. Specification for packaged product only.
- 2:** Guaranteed by design over the operating temperature range. Not 100% production tested.
 - 3:** Accuracy specification does not include quantization noise, which may be up to $\pm 1/2$ LSB.
 - 4:** T_D is the temperature of the remote diode junction. Testing is performed using a single unit of one of the transistors listed in [Table 5-1](#).
 - 5:** Current into the DATA pin will result in self-heating of the device. Sink current should be minimized for best accuracy.

MIC281

TEMPERATURE SPECIFICATIONS

Parameters	Sym.	Min.	Typ.	Max.	Units	Conditions
Temperature Ranges						
Storage Temperature	T_S	-65	—	+150	°C	—
Ambient Temperature Range	T_A	-55	—	+125	°C	—
Lead Temperature Soldering	—	—	—	+220 ±5	°C	Vapor Phase, 60 sec.
		—	—	+235 ±5	°C	Infrared, 15 sec.
Package Thermal Resistances						
SOT23-6	θ_{JA}	—	230	—	°C/W	—

Note 1: The maximum allowable power dissipation is a function of ambient temperature, the maximum allowable junction temperature and the thermal resistance from junction to air (i.e., T_A , T_J , θ_{JA}). Exceeding the maximum allowable power dissipation will cause the device operating junction temperature to exceed the maximum +150°C rating. Sustained junction temperatures above +150°C can impact the device reliability.

2.0 TYPICAL PERFORMANCE CURVES

Note: The graphs and tables provided following this note are a statistical summary based on a limited number of samples and are provided for informational purposes only. The performance characteristics listed herein are not tested or guaranteed. In some graphs or tables, the data presented may be outside the specified operating range (e.g., outside specified power supply range) and therefore outside the warranted range.

$V_{DD} = 3.3V$; $T_A = 25^\circ C$, unless otherwise noted.

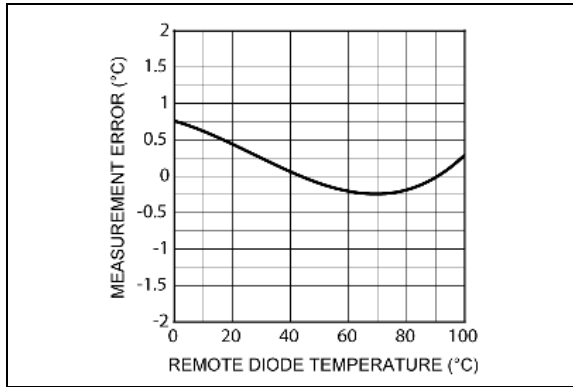

FIGURE 2-1: Remote Temperature Measurement Error.

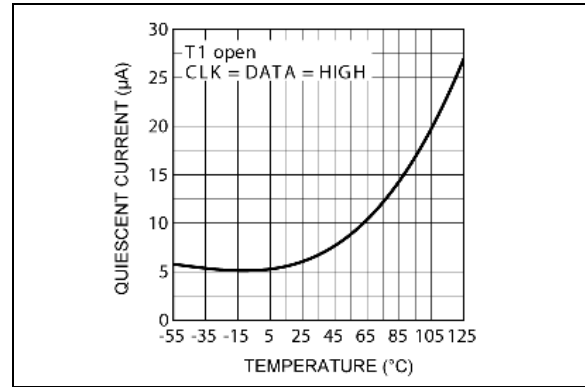

FIGURE 2-4: Quiescent Current vs. Temperature in Shutdown Mode.

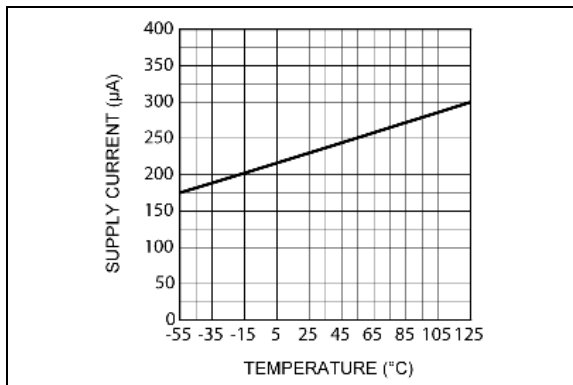

FIGURE 2-2: Supply Current vs. Temperature for $V_{DD} = 3.3V$.

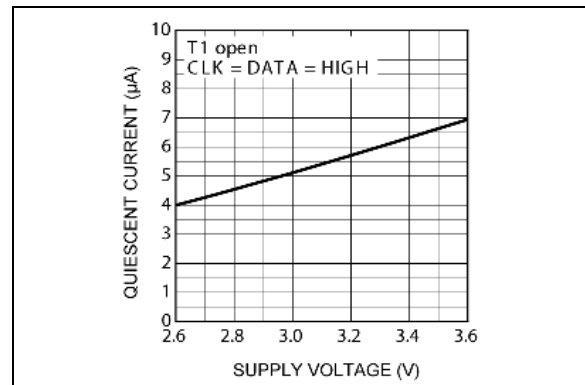

FIGURE 2-5: Quiescent Current vs. Supply Voltage in Shutdown Mode.

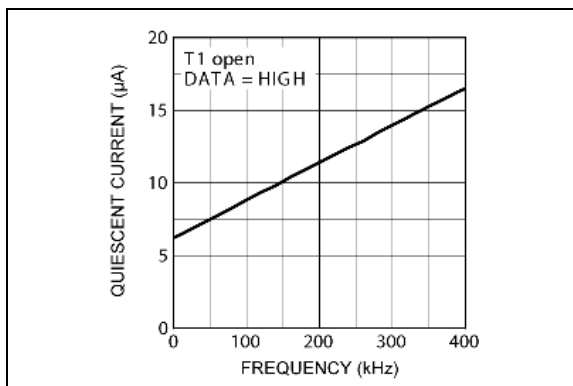

FIGURE 2-3: Quiescent Current vs. Clock Frequency in Shutdown Mode.

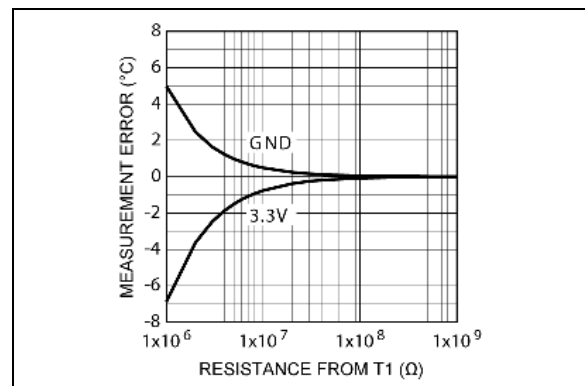

FIGURE 2-6: Measurement Error vs. PCB Leakage to +3.3V/GND.

MIC281

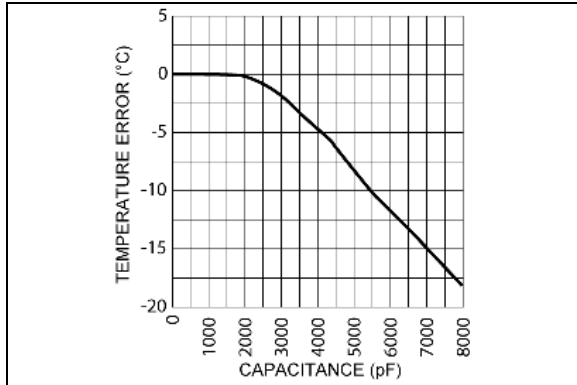

FIGURE 2-7: Remote Temperature Error vs. Capacitance on T1.

Timing Diagram

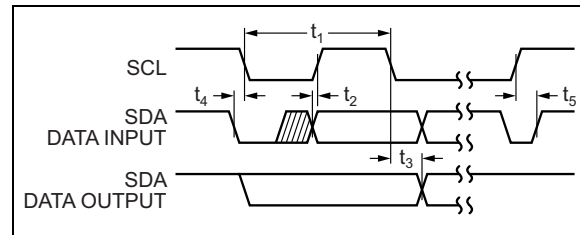

FIGURE 2-10: Serial Interface Timing.

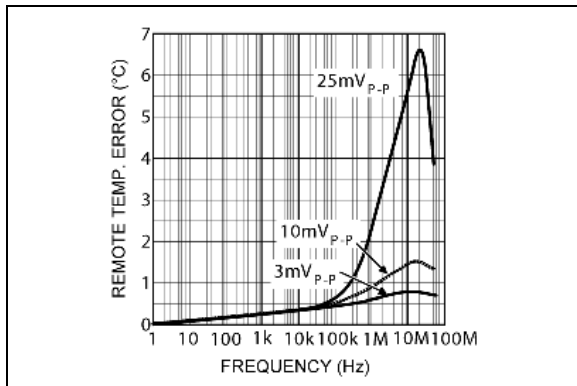

FIGURE 2-8: Error Due to Noise on the Base of Remote Transistor.

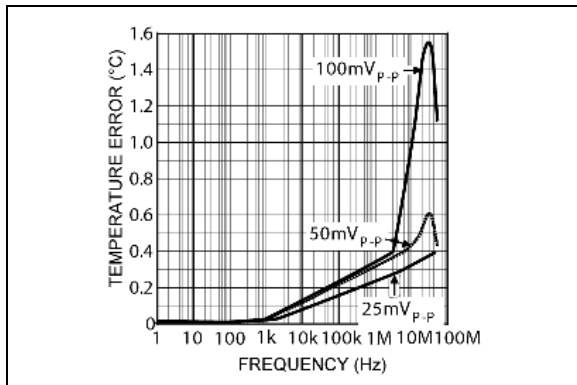

FIGURE 2-9: Error Due to Noise on the Collector of Remote Transistor.

3.0 PIN DESCRIPTIONS

The descriptions of the pins are listed in [Table 3-1](#).

TABLE 3-1: PIN FUNCTION TABLE

Pin Number	Symbol	Description
1	VDD	Analog input: Power supply input to the IC.
2	GND	Ground return for all IC functions.
3	T1	Analog input: Connection to remote diode junction.
4	CLK	Digital input: Serial bit clock input.
5	DATA	Digital input/output: Open-drain. Serial data input/output.
6	NC	No connection: Must be left unconnected.

MIC281

4.0 FUNCTIONAL DESCRIPTION

4.1 Serial Port Operation

The MIC281 uses standard SMBus Write_Byte and Read_Byte operations for communication with its host. The SMBus Write_Byte operation involves sending the device's client address (with the R/W bit low to signal a write operation), followed by a command byte and the data byte. The SMBus Read_Byte operation is a composite write and read operation: the host first sends the device's client address followed by the command byte, as in a write operation. A new start bit must then be sent to the MIC281, followed by a repeat of the client address with the R/W bit (LSB) set to the high (read) state. The data to be read from the part may then be clocked out. These protocols are shown in Figure 4-1 and Figure 4-2.

The Command byte is eight bits (one byte) wide. This byte carries the address of the MIC281 register to be operated upon. The command byte values corresponding to the various MIC281 registers are shown in Table 4-1. Other command byte values are reserved, and should not be used.

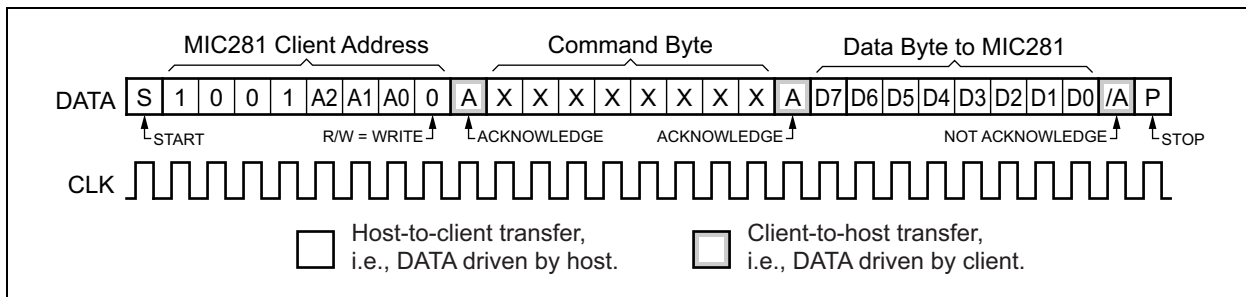

FIGURE 4-1: Write_Byte Protocol.

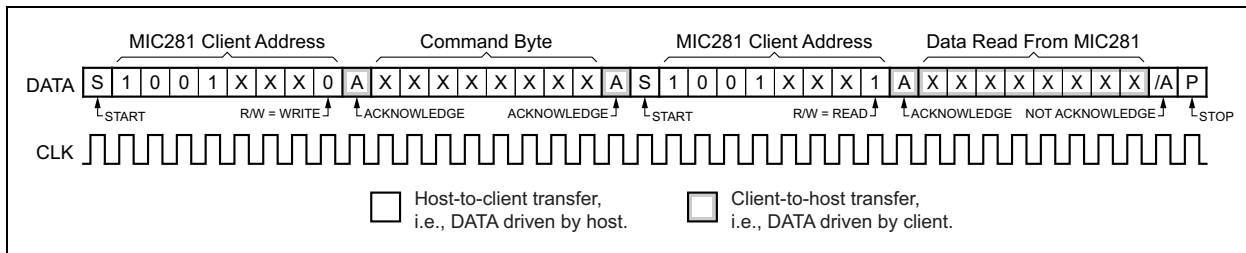

FIGURE 4-2: Read_Byte Protocol.

TABLE 4-1: MIC281 REGISTER ADDRESSES

Target Register		Command Byte Value		Power-On Default
Label	Description	Read	Write	
TEMP	Remote temperature result	01 _h	N/A	00 _h (0°C)
CONFIG	Configuration	03 _h	03 _h	80 _h
MFG_ID	Manufacturer identification	FE _h	N/A	2A _h
DEV_ID	Device and revision identification	FF _h	N/A	0x _h (Note 1)

Note 1: The lower nibble contains the die revision level (e.g., Rev. 0 = 00h).

4.2 Client Address

The MIC281 will only respond to its own unique client address. A match between the MIC281's address and the address specified in the serial bit stream must be made to initiate communication. The MIC281's client address is fixed at the time of manufacture. Eight different client addresses are available as determined by the part number. See [Table 4-2](#) and the [Product Identification System](#).

TABLE 4-2: MIC281 CLIENT ADDRESSES

Part Number	Client Address
MIC281-0YM6	1001 000 _b = 90 _h
MIC281-1YM6	1001 001 _b = 92 _h
MIC281-2YM6	1001 010 _b = 94 _h
MIC281-3YM6	1001 011 _b = 96 _h
MIC281-4YM6	1001 100 _b = 98 _h
MIC281-5YM6	1001 101 _b = 9A _h
MIC281-6YM6	1001 110 _b = 9C _h
MIC281-7YM6	1001 111 _b = 9E _h

4.3 Temperature Data Format

The least-significant bit of the temperature register represents one degree Centigrade. The values are in a two's complement format, wherein the most significant bit (D7) represents the sign: zero for positive temperatures and one for negative temperatures. [Table 4-3](#) shows examples of the data format used by the MIC281 for temperatures.

TABLE 4-3: DIGITAL TEMPERATURE FORMAT

Temperature	Binary	Hex
+127°C	0111 1111	7F
+125°C	0111 1101	7D
+25°C	0001 1001	19
+1°C	0000 0001	01
0°C	0000 0000	00
-1°C	1111 1111	FF
-25°C	1110 0111	E7
-125°C	1000 0011	83
-128°C	1000 0000	80

4.4 Diode Faults

The MIC281 is designed to respond in a failsafe manner to diode faults. If an internal or external fault occurs in the temperature sensing circuitry, such as T1 being open or shorted to VDD or GND, the temperature result will be reported as the maximum full-scale value of +127°C. Note that diode faults will not be detected until the first A/D conversion cycle is completed following power-up or exiting shutdown mode.

4.5 Shutdown Mode

Setting the shutdown bit in the configuration register will cause the MIC281 to cease operation. The A/D converter will stop and power consumption will drop to the I_{SHDN} level. No registers will be affected by entering shutdown mode. The last temperature reading will persist in the TEMP register.

MIC281

4.6 Detailed Register Descriptions

4.6.1 REMOTE TEMPERATURE RESET (TEMP) 8-BITS, READ ONLY

TABLE 4-4: REMOTE TEMPERATURE RESET

Local Temperature Result Register							
D[7]	D[6]	D[5]	D[4]	D[3]	D[2]	D[1]	D[0]
read-only	read-only	read-only	read-only	read-only	read-only	read-only	read-only
Temperature data from ADC.							
Bit		Function				Operation	
D[7:0]		Measured temperature data for the remote zone.				Read only.	

Power-up default value: 0000 0000_b = 00_h = (0°C) (Note 1)

Read command byte: 0000 0001_b = 01_h

Each LSB represents one degree centigrade. The values are in a twos complement binary format such that 0°C is reported as 0000 0000_b. See the Temperature Data Format section for more details.

Note 1: TEMP will contain measured temperature data after the completion of one conversion.

4.6.2 CONFIGURATION REGISTER (CONFIG) 8-BITS, READ/WRITE

TABLE 4-5: CONFIGURATION REGISTER

Configuration Register							
D[7]	D[6]	D[5]	D[4]	D[3]	D[2]	D[1]	D[0]
reserved	reserved	reserved	reserved	reserved	reserved	reserved	write-only
Reserved	Shutdown (SHDN)	Reserved					
Bit		Function			Operation (Note 2)		
D7		Reserved			Always writes as zero; reads undefined		
D6		Shutdown bit			0 = normal operation; 1 = shutdown		
D[5:0]		Reserved			Always writes as zero; reads undefined		

2: Any write to CONFIG will result in any A/D conversion in progress being aborted and the result discarded. The A/D will begin a new conversion sequence once the write operation is complete.

Power-up default value: x0xx xxxx_b (not in shutdown mode)

Command byte: 0000 0011_b = 03_h

4.6.3 MANUFACTURER ID REGISTER (MFG_ID) 8-BITS, READ ONLY

TABLE 4-6: MANUFACTURER ID REGISTER

Manufacturer ID Register							
D[7]	D[6]	D[5]	D[4]	D[3]	D[2]	D[1]	D[0]
read-only	read-only	read-only	read-only	read-only	read-only	read-only	read-only
0	0	1	0	1	0	1	0
Bit		Function				Operation	
D[7:0]		Identifies Microchip Technology Inc. as the manufacturer of the device.				Read only. Always returns 2A _h	

Power-up default value: 0010 1010_b = 2A_h

Read command byte: 1111 1110_b = FE_h

4.6.4 DIE REVISION REGISTER (DIE_REV) 8-BITS, READ ONLY

TABLE 4-7: DIE REVISION REGISTER

Die Revision Register							
D[7] read-only	D[6] read-only	D[5] read-only	D[4] read-only	D[3] read-only	D[2] read-only	D[1] read-only	D[0] read-only
MIC281 die revision number							
Bit		Function				Operation	
D[7:0]		Identifies the device revision number.				Read only.	

Power-up default value: [device revision number]_h

Read command byte: 1111 1111_b = FF_h

MIC281

5.0 APPLICATION INFORMATION

5.1 Remote Diode Section

Most small-signal PNP transistors with characteristics similar to the JEDEC 2N3906 will perform well as remote temperature sensors. Table 5-1 lists several examples of such parts that Microchip has tested for use with the MIC281. Other transistors equivalent to these should also work well.

TABLE 5-1: TRANSISTORS SUITABLE FOR USE AS REMOTE DIODES

Vendor	Part Number	Package
Fairchild Semiconductor	MMBT3906	SOT23
On Semiconductor	MMBT3906L	SOT23
Philips Semiconductor	SMBT3906	SOT23
Samsung Semiconductor	KST3906-TF	SOT23

5.2 Minimizing Errors

5.2.1 SELF-HEATING

One concern when using a part with the temperature accuracy and resolution of the MIC281 is to avoid errors induced by self-heating ($V_{DD} \times I_{DD}$) + ($V_{OL} \times I_{OL}$). In order to understand what level of error this might represent, and how to reduce that error, the dissipation in the MIC281 must be calculated and its effects reduced to a temperature offset. The worst-case operating condition for the MIC281 is when $V_{DD} = 3.6V$. The maximum power dissipated in the part is given in the following equation:

EQUATION 5-1:

$$P_D = (I_{DD} \times V_{DD}) + (I_{OL(DATA)} \times V_{OL(DATA)})$$
$$P_D = (0.4mA \times 3.6V) + (6mA \times 0.5V)$$
$$P_D = 4.44mW$$

The $R_{\theta JA}$ of the SOT23-6 package is $230^{\circ}C/W$, therefore the theoretical maximum self-heating is:

EQUATION 5-2:

$$4.44mW \times 230^{\circ}C/W = 1.02^{\circ}C$$

In most applications, the DATA pin will have a duty cycle of substantially below 25% in the low state. These considerations, combined with more typical device and application parameters, give a better system-level view of device self-heating. This is illustrated by the next equation. In any application, the best approach is to verify performance against calculation in the final application environment. This is especially true when dealing with systems for which some temperature data may be poorly defined or unobtainable except by empirical means.

EQUATION 5-3:

$$P_D = (I_{DD} \times V_{DD}) + (I_{OL(DATA)} \times V_{OL(DATA)})$$
$$P_D = (0.23mA \times 3.3V) + (25\% \times 1.5mA \times 0.15V)$$
$$P_D = 0.815mW$$

The $R_{\theta JA}$ of the SOT23-6 package is $230^{\circ}C/W$, therefore the typical self-heating is:

EQUATION 5-4:

$$0.815mW \times 230^{\circ}C/W = 0.188^{\circ}C$$

5.2.2 SERIES RESISTANCE

The operation of the MIC281 depends upon sensing the V_{CB-E} of a diode-connected PNP transistor (diode) at two different current levels. For remote temperature measurements, this is done using an external diode connected between T1 and ground. Because this technique relies upon measuring the relatively small voltage difference resulting from two levels of current through the external diode, any resistance in series

with the external diode will cause an error in the temperature reading from the MIC281. A good rule of thumb is that for each ohm in series with the external transistor, there will be a 0.9°C error in the MIC281's temperature measurement. It is not difficult to keep the series resistance well below an ohm (typically <0.1Ω), so this will rarely be an issue.

5.3 Filter Capacitor Selection

It is usually desirable to employ a filter capacitor between the T1 and GND pins of the MIC281. The use of this capacitor is recommended in environments with a lot of high frequency noise (such as digital switching noise), or if long traces or wires are used to connect to the remote diode. The recommended total capacitance from the T1 pin to GND is 2200 pF. If the remote diode is to be at a distance of more than six-to-twelve inches from the MIC281, using twisted pair wiring or shielded microphone cable for the connections to the diode can significantly reduce noise pickup. If using a long run of shielded cable, remember to subtract the cable's conductor-to-shield capacitance from the 2200 pF total capacitance.

5.4 Layout Considerations

The following guidelines should be kept in mind when designing and laying out circuits using the MIC281.

1. Place the MIC281 as close to the remote diode as possible, while taking care to avoid severe noise sources such as high frequency power transformers, CRTs, memory and data busses, and the like.
2. Because any conductance from the various voltages on the PC board and the T1 line can induce serious errors, it is good practice to guard the remote diode's emitter trace with a

pair of ground traces. These ground traces should be returned to the MIC281's own ground pin. They should not be grounded at any other part of their run. However, it is highly desirable to use these guard traces to carry the diode's own ground return back to the ground pin of the MIC281, thereby providing a Kelvin connection for the base of the diode. See [Figure 5-1](#).

3. When using the MIC281 to sense the temperature of a processor or other device which has an integral thermal diode, e.g., Intel's Pentium III, connect the emitter and base of the remote sensor to the MIC281 using the guard traces and Kelvin return shown in [Figure 5-1](#). The collector of the remote diode is typically inaccessible to the user on these devices.
4. Due to the small currents involved in the measurement of the remote diode's ΔV_{BE} , it is important to adequately clean the PC board after soldering to prevent current leakage. This is most likely to show up as an issue in situations where water-soluble soldering fluxes are used.
5. In general, wider traces for the ground and T1 lines will help reduce susceptibility to radiated noise (wider traces are less inductive). Use trace widths and spacing of 10 mm wherever possible and provide a ground plane under the MIC281 and under the connections from the MIC281 to the remote diode. This will help guard against stray noise pickup.
6. Always place a good quality power supply bypass capacitor directly adjacent to, or underneath, the MIC281. This should be a 0.1 μF ceramic capacitor. Surface-mount parts provide the best bypassing because of their low inductance.

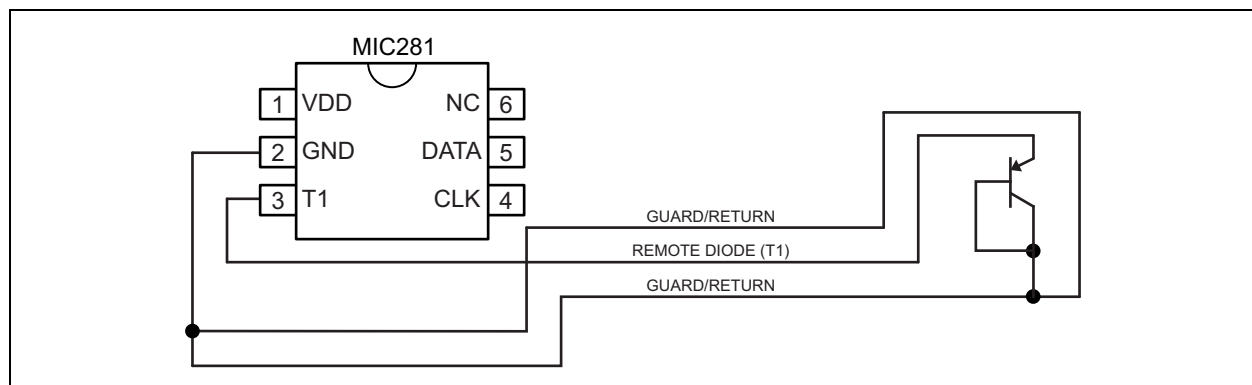

FIGURE 5-1: Guard Traces/Kelvin Ground Returns.

MIC281

6.0 PACKAGING INFORMATION

6.1 Package Marking Information

6-Pin SOT23*

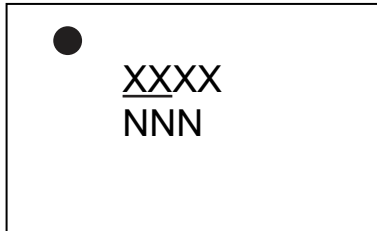

Example

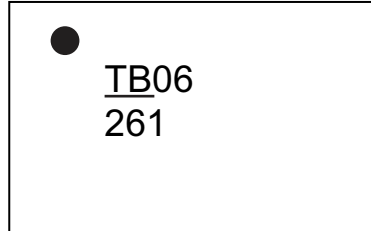

Part Number	Marking
MIC281-0YM6-TR	<u>TB00</u>
MIC281-1YM6-TR	<u>TB01</u>
MIC281-2YM6-TR	<u>TB02</u>
MIC281-3YM6-TR	<u>TB03</u>
MIC281-4YM6-TR	<u>TB04</u>
MIC281-5YM6-TR	<u>TB05</u>
MIC281-6YM6-TR	<u>TB06</u>
MIC281-7YM6-TR	<u>TB07</u>

<p>Legend: XX...X Product code or customer-specific information Y Year code (last digit of calendar year) YY Year code (last 2 digits of calendar year) WW Week code (week of January 1 is week '01') NNN Alphanumeric traceability code (e3) Pb-free JEDEC® designator for Matte Tin (Sn) * This package is Pb-free. The Pb-free JEDEC designator ((e3)) can be found on the outer packaging for this package.</p> <p>●, ▲, ▼ Pin one index is identified by a dot, delta up, or delta down (triangle mark).</p>
<p>Note: In the event the full Microchip part number cannot be marked on one line, it will be carried over to the next line, thus limiting the number of available characters for customer-specific information. Package may or may not include the corporate logo.</p> <p>Underbar () and/or Overbar () symbol may not be to scale.</p>

6-Lead SOT23 Package Outline and Recommended Land Pattern

TITLE

6 LEAD SOT23 PACKAGE OUTLINE & RECOMMENDED LAND PATTERN

DRAWING #	SOT23-6LD-PL-1	UNIT	MM
------------------	----------------	-------------	----

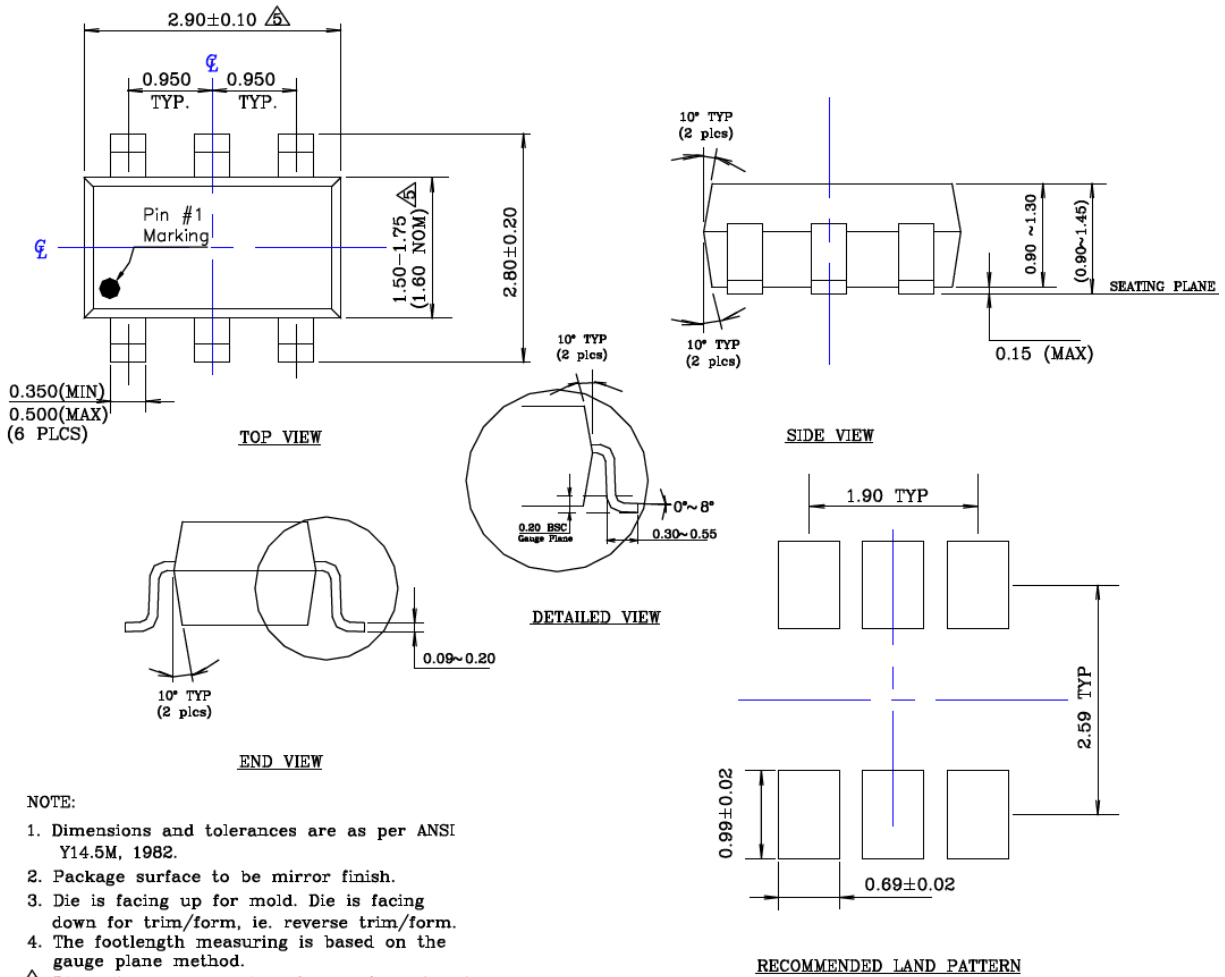

Note: For the most current package drawings, please see the Microchip Packaging Specification located at <http://www.microchip.com/packaging>.

MIC281

NOTES:

APPENDIX A: REVISION HISTORY

Revision A (December 2020)

- Converted Micrel data sheet MIC281 to Microchip data sheet DS20006468A.
- Minor grammatical corrections throughout.

MIC281

NOTES:

PRODUCT IDENTIFICATION SYSTEM

To order or obtain information, e.g., on pricing or delivery, contact your local Microchip representative or sales office.

<u>PART NO.</u>		<u>-X</u>	<u>X</u>	<u>XX</u>	<u>-XX</u>
Device	Client Address	Temp. Range	Package	Media Type	
Device:	MIC281:	Low-Cost Thermal Sensor			
	0 =	1001 000 _{x_b}			
	1 =	1001 001 _{x_b}			
	2 =	1001 010 _{x_b}			
Client Address:	3 =	1001 011 _{x_b}			
	4 =	1001 100 _{x_b}			
	5 =	1001 101 _{x_b}			
	6 =	1001 110 _{x_b}			
	7 =	1001 111 _{x_b}			
Ambient Temperature Range:	Y =	-55°C to +125°C			
Package:	M6 =	6-Lead SOT23			
Media Type	TR =	3,000/Reel			

Examples:

- a) MIC281-0YM6-TR: Low-Cost Thermal Sensor, 1001 000_{x_b} Client Address, -55°C to +125°C Ambient Temperature Range, 6-Lead SOT23, 3,000/Reel
- b) MIC281-2YM6-TR: Low-Cost Thermal Sensor, 1001 001_{x_b} Client Address, -55°C to +125°C Ambient Temperature Range, 6-Lead SOT23, 3,000/Reel
- c) MIC281-5YM6-TR: Low-Cost Thermal Sensor, 1001 101_{x_b} Client Address, -55°C to +125°C Ambient Temperature Range, 6-Lead SOT23, 3,000/Reel
- d) MIC281-7YM6-TR: Low-Cost Thermal Sensor, 1001 111_{x_b} Client Address, -55°C to +125°C Ambient Temperature Range, 6-Lead SOT23, 3,000/Reel

Note 1: Tape and Reel identifier only appears in the catalog part number description. This identifier is used for ordering purposes and is not printed on the device package. Check with your Microchip Sales Office for package availability with the Tape and Reel option.

MIC281

NOTES:

Note the following details of the code protection feature on Microchip devices:

- Microchip products meet the specifications contained in their particular Microchip Data Sheet.
- Microchip believes that its family of products is secure when used in the intended manner and under normal conditions.
- There are dishonest and possibly illegal methods being used in attempts to breach the code protection features of the Microchip devices. We believe that these methods require using the Microchip products in a manner outside the operating specifications contained in Microchip's Data Sheets. Attempts to breach these code protection features, most likely, cannot be accomplished without violating Microchip's intellectual property rights.
- Microchip is willing to work with any customer who is concerned about the integrity of its code.
- Neither Microchip nor any other semiconductor manufacturer can guarantee the security of its code. Code protection does not mean that we are guaranteeing the product is "unbreakable." Code protection is constantly evolving. We at Microchip are committed to continuously improving the code protection features of our products. Attempts to break Microchip's code protection feature may be a violation of the Digital Millennium Copyright Act. If such acts allow unauthorized access to your software or other copyrighted work, you may have a right to sue for relief under that Act.

Information contained in this publication is provided for the sole purpose of designing with and using Microchip products. Information regarding device applications and the like is provided only for your convenience and may be superseded by updates. It is your responsibility to ensure that your application meets with your specifications.

THIS INFORMATION IS PROVIDED BY MICROCHIP "AS IS". MICROCHIP MAKES NO REPRESENTATIONS OR WARRANTIES OF ANY KIND WHETHER EXPRESS OR IMPLIED, WRITTEN OR ORAL, STATUTORY OR OTHERWISE, RELATED TO THE INFORMATION INCLUDING BUT NOT LIMITED TO ANY IMPLIED WARRANTIES OF NON-INFRINGEMENT, MERCHANTABILITY, AND FITNESS FOR A PARTICULAR PURPOSE OR WARRANTIES RELATED TO ITS CONDITION, QUALITY, OR PERFORMANCE.

IN NO EVENT WILL MICROCHIP BE LIABLE FOR ANY INDIRECT, SPECIAL, PUNITIVE, INCIDENTAL OR CONSEQUENTIAL LOSS, DAMAGE, COST OR EXPENSE OF ANY KIND WHATSOEVER RELATED TO THE INFORMATION OR ITS USE, HOWEVER CAUSED, EVEN IF MICROCHIP HAS BEEN ADVISED OF THE POSSIBILITY OR THE DAMAGES ARE FORESEEABLE. TO THE FULLEST EXTENT ALLOWED BY LAW, MICROCHIP'S TOTAL LIABILITY ON ALL CLAIMS IN ANY WAY RELATED TO THE INFORMATION OR ITS USE WILL NOT EXCEED THE AMOUNT OF FEES, IF ANY, THAT YOU HAVE PAID DIRECTLY TO MICROCHIP FOR THE INFORMATION. Use of Microchip devices in life support and/or safety applications is entirely at the buyer's risk, and the buyer agrees to defend, indemnify and hold harmless Microchip from any and all damages, claims, suits, or expenses resulting from such use. No licenses are conveyed, implicitly or otherwise, under any Microchip intellectual property rights unless otherwise stated.

Trademarks

The Microchip name and logo, the Microchip logo, Adaptec, AnyRate, AVR, AVR logo, AVR Freaks, BesTime, BitCloud, chipKIT, chipKIT logo, CryptoMemory, CryptoRF, dsPIC, FlashFlex, flexPWR, HELDO, IGL00, JukeBlox, KeeLoq, Kleer, LANCheck, LinkMD, maXStylus, maXTouch, MediaLB, megaAVR, Microsemi, Microsemi logo, MOST, MOST logo, MPLAB, OptoLyzer, PackeTime, PIC, picoPower, PICSTART, PIC32 logo, PolarFire, Prochip Designer, QTouch, SAM-BA, SenGenuity, SpyNIC, SST, SST Logo, SuperFlash, Symmetricom, SyncServer, Tachyon, TimeSource, tinyAVR, UNI/O, Vectron, and XMEGA are registered trademarks of Microchip Technology Incorporated in the U.S.A. and other countries.

AgileSwitch, APT, ClockWorks, The Embedded Control Solutions Company, EtherSynch, FlashTec, Hyper Speed Control, HyperLight Load, IntelliMOS, Libero, motorBench, mTouch, Powermite 3, Precision Edge, ProASIC, ProASIC Plus, ProASIC Plus logo, Quiet-Wire, SmartFusion, SyncWorld, Temux, TimeCesium, TimeHub, TimePictra, TimeProvider, WinPath, and ZL are registered trademarks of Microchip Technology Incorporated in the U.S.A.

Adjacent Key Suppression, AKS, Analog-for-the-Digital Age, Any Capacitor, AnyIn, AnyOut, Augmented Switching, BlueSky, BodyCom, CodeGuard, CryptoAuthentication, CryptoAutomotive, CryptoCompanion, CryptoController, dsPICDEM, dsPICDEM.net, Dynamic Average Matching, DAM, ECAN, Espresso T1S, EtherGREEN, IdealBridge, In-Circuit Serial Programming, ICSP, INICnet, Intelligent Paralleling, Inter-Chip Connectivity, JitterBlocker, maxCrypto, maxView, memBrain, Mindi, MiWi, MPASM, MPF, MPLAB Certified logo, MPLIB, MPLINK, MultiTRAK, NetDetach, Omniscient Code Generation, PICDEM, PICDEM.net, PICkit, PICtail, PowerSmart, PureSilicon, QMatrix, REAL ICE, Ripple Blocker, RTAX, RTG4, SAM-ICE, Serial Quad I/O, simpleMAP, SimpliPHY, SmartBuffer, SMART-I.S., storClad, SQI, SuperSwitcher, SuperSwitcher II, Switchtec, SynchroPHY, Total Endurance, TSHARC, USBCheck, VariSense, VectorBlox, VeriPHY, ViewSpan, WiperLock, XpressConnect, and ZENA are trademarks of Microchip Technology Incorporated in the U.S.A. and other countries.

SQTP is a service mark of Microchip Technology Incorporated in the U.S.A.

The Adaptec logo, Frequency on Demand, Silicon Storage Technology, and Symmcom are registered trademarks of Microchip Technology Inc. in other countries.

GestIC is a registered trademark of Microchip Technology Germany II GmbH & Co. KG, a subsidiary of Microchip Technology Inc., in other countries.

All other trademarks mentioned herein are property of their respective companies.

© 2020, Microchip Technology Incorporated, All Rights Reserved.

ISBN: 978-1-5224-7323-7

For information regarding Microchip's Quality Management Systems, please visit www.microchip.com/quality.



MICROCHIP

Worldwide Sales and Service

AMERICAS

Corporate Office
2355 West Chandler Blvd.
Chandler, AZ 85224-6199
Tel: 480-792-7200
Fax: 480-792-7277
Technical Support:
<http://www.microchip.com/support>
Web Address:
www.microchip.com

Atlanta

Duluth, GA
Tel: 678-957-9614
Fax: 678-957-1455

Austin, TX

Tel: 512-257-3370

Boston

Westborough, MA
Tel: 774-760-0087
Fax: 774-760-0088

Chicago

Itasca, IL
Tel: 630-285-0071
Fax: 630-285-0075

Dallas

Addison, TX
Tel: 972-818-7423
Fax: 972-818-2924

Detroit

Novi, MI
Tel: 248-848-4000

Houston, TX

Tel: 281-894-5983

Indianapolis

Noblesville, IN
Tel: 317-773-8323
Fax: 317-773-5453
Tel: 317-536-2380

Los Angeles

Mission Viejo, CA
Tel: 949-462-9523
Fax: 949-462-9608
Tel: 951-273-7800

Raleigh, NC

Tel: 919-844-7510

New York, NY

Tel: 631-435-6000

San Jose, CA

Tel: 408-735-9110
Tel: 408-436-4270

Canada - Toronto

Tel: 905-695-1980
Fax: 905-695-2078

ASIA/PACIFIC

Australia - Sydney
Tel: 61-2-9868-6733

China - Beijing
Tel: 86-10-8569-7000

China - Chengdu
Tel: 86-28-8665-5511

China - Chongqing
Tel: 86-23-8980-9588

China - Dongguan
Tel: 86-769-8702-9880

China - Guangzhou
Tel: 86-20-8755-8029

China - Hangzhou
Tel: 86-571-8792-8115

China - Hong Kong SAR
Tel: 852-2943-5100

China - Nanjing
Tel: 86-25-8473-2460

China - Qingdao
Tel: 86-532-8502-7355

China - Shanghai
Tel: 86-21-3326-8000

China - Shenyang
Tel: 86-24-2334-2829

China - Shenzhen
Tel: 86-755-8864-2200

China - Suzhou
Tel: 86-186-6233-1526

China - Wuhan
Tel: 86-27-5980-5300

China - Xian
Tel: 86-29-8833-7252

China - Xiamen
Tel: 86-592-2388138

China - Zhuhai
Tel: 86-756-3210040

ASIA/PACIFIC

India - Bangalore
Tel: 91-80-3090-4444

India - New Delhi
Tel: 91-11-4160-8631

India - Pune
Tel: 91-20-4121-0141

Japan - Osaka
Tel: 81-6-6152-7160

Japan - Tokyo
Tel: 81-3-6880-3770

Korea - Daegu
Tel: 82-53-744-4301

Korea - Seoul
Tel: 82-2-554-7200

Malaysia - Kuala Lumpur
Tel: 60-3-7651-7906

Malaysia - Penang
Tel: 60-4-227-8870

Philippines - Manila
Tel: 63-2-634-9065

Singapore
Tel: 65-6334-8870

Taiwan - Hsin Chu
Tel: 886-3-577-8366

Taiwan - Kaohsiung
Tel: 886-7-213-7830

Taiwan - Taipei
Tel: 886-2-2508-8600

Thailand - Bangkok
Tel: 66-2-694-1351

Vietnam - Ho Chi Minh
Tel: 84-28-5448-2100

EUROPE

Austria - Wels
Tel: 43-7242-2244-39
Fax: 43-7242-2244-393

Denmark - Copenhagen
Tel: 45-4485-5910
Fax: 45-4485-2829

Finland - Espoo
Tel: 358-9-4520-820

France - Paris
Tel: 33-1-69-53-63-20
Fax: 33-1-69-30-90-79

Germany - Garching
Tel: 49-8931-9700

Germany - Haan
Tel: 49-2129-3766400

Germany - Heilbronn
Tel: 49-7131-72400

Germany - Karlsruhe
Tel: 49-721-625370

Germany - Munich
Tel: 49-89-627-144-0
Fax: 49-89-627-144-44

Germany - Rosenheim
Tel: 49-8031-354-560

Israel - Ra'anana
Tel: 972-9-744-7705

Italy - Milan
Tel: 39-0331-742611
Fax: 39-0331-466781

Italy - Padova
Tel: 39-049-7625286

Netherlands - Drunen
Tel: 31-416-690399
Fax: 31-416-690340

Norway - Trondheim
Tel: 47-7288-4388

Poland - Warsaw
Tel: 48-22-3325737

Romania - Bucharest
Tel: 40-21-407-87-50

Spain - Madrid
Tel: 34-91-708-08-90
Fax: 34-91-708-08-91

Sweden - Gothenberg
Tel: 46-31-704-60-40

Sweden - Stockholm
Tel: 46-8-5090-4654

UK - Wokingham
Tel: 44-118-921-5800
Fax: 44-118-921-5820