

THIS DRAWING IS UNPUBLISHED. RELEASED FOR PUBLICATION  
 © COPYRIGHT BY TYCO ELECTRONICS CORPORATION. ALL RIGHTS RESERVED.

LOC	DIST	REVISIONS			
P	LTR	DESCRIPTION	DATE	DWN	APVD
AJ	16	A	REV PER ECO 06-002539	06APR06	GB JH
		A1	REVISED PER ECO-09-024606	31OCT09	KK AEG

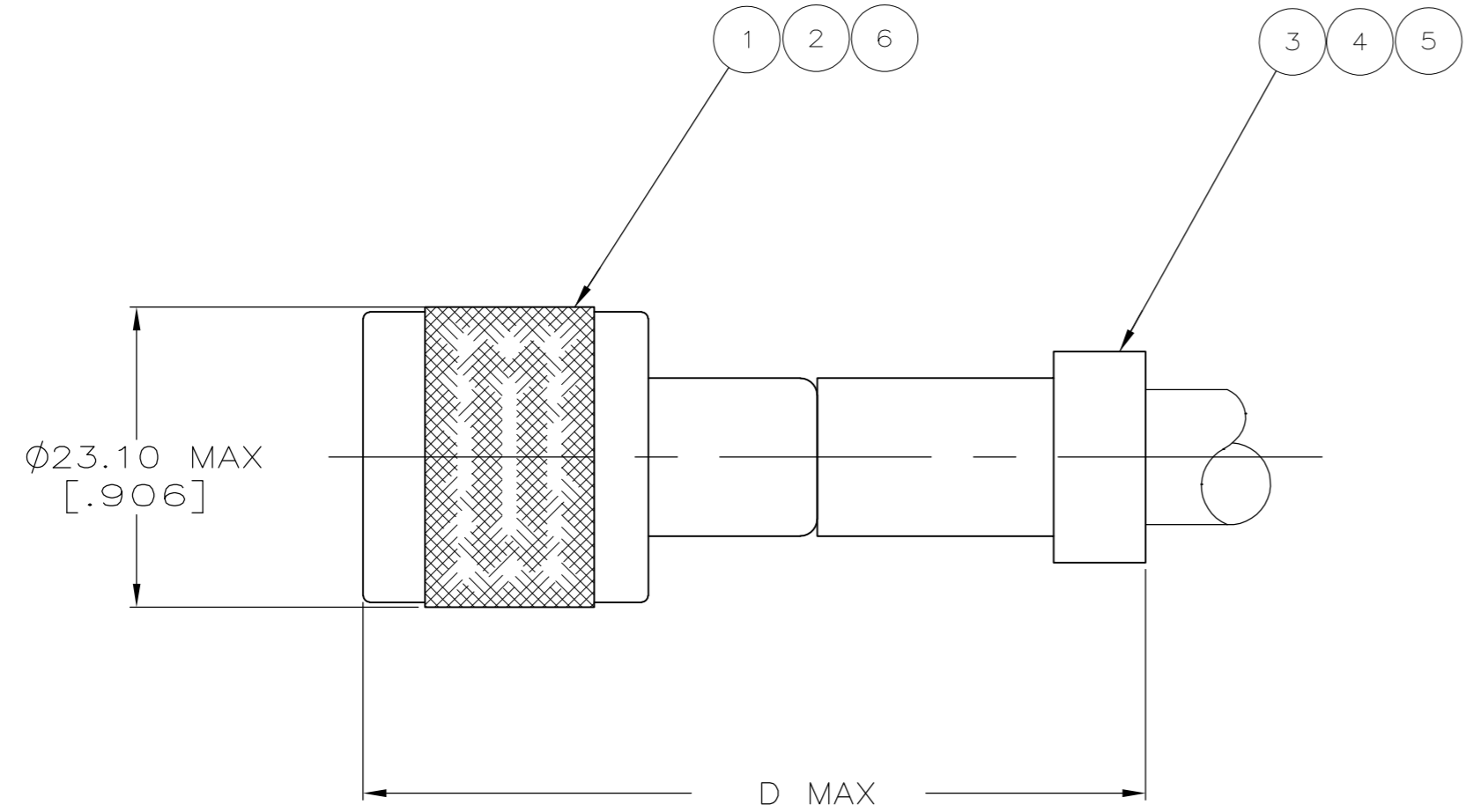

- 1 FOR USE WITH: RG-149/U, & 391/U STANDARD CABLE.
- 2 FOR USE WITH: RG-150/U, & 392/U ARMOR CABLE.
- 3 USE CRIMPING TOOL: 220015-1 FOR STANDARD CABLE.
- 4 USE CRIMPING TOOLS: 220015-1, & 220042-1 FOR ARMOR CABLE.
- 5 USE CRIMPING TOOL: 220045-3.
- 6. SEE INSTRUCTION SHEET 408-2338.
- 7 P/N 5225744-4 IS RATED AT 2300 VAC.
- 8 OBSOLETE PARTS: OBSOLETE CIS STREAMLINING PER D.RENAUD/D.SINISI

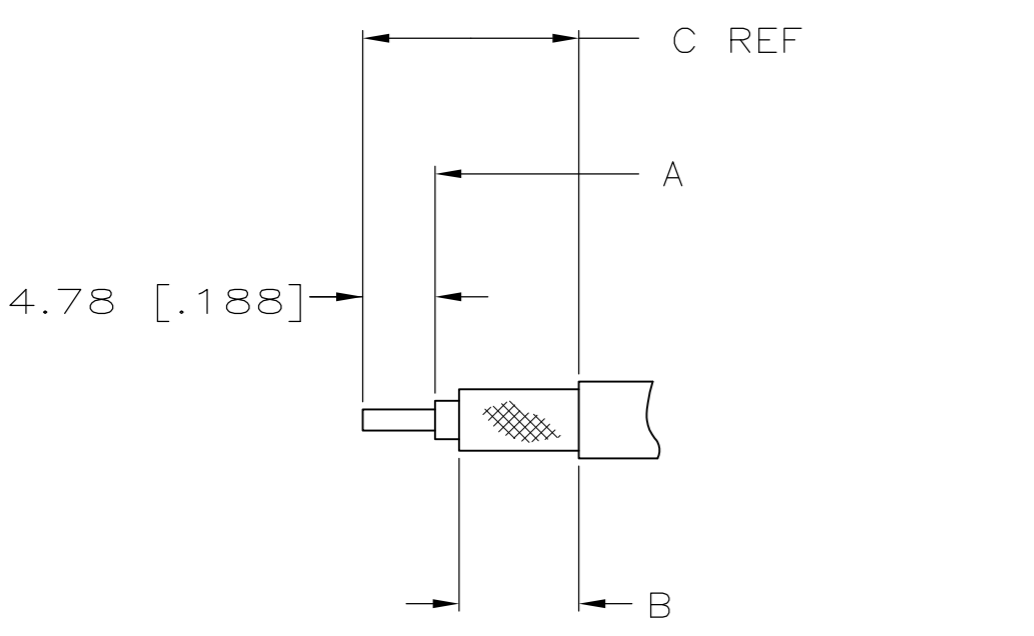

RECOMMENDED STRIP LENGTH FOR STANDARD COAX CABLE

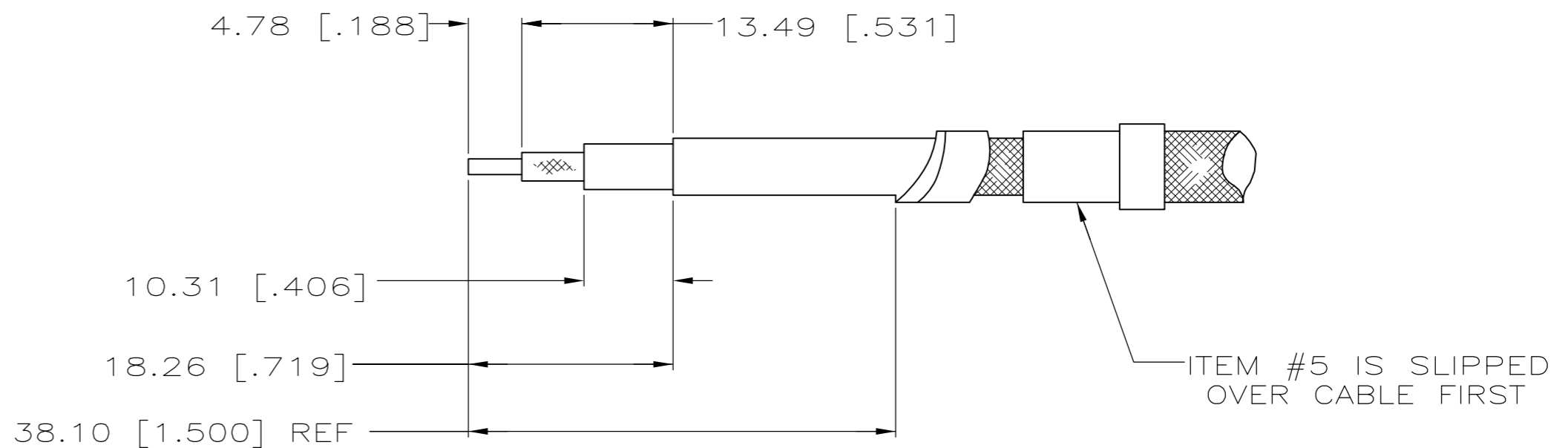

RECOMMENDED STRIP LENGTH FOR ARMOR CABLE

7	RG-59/U CABLE	5	225592-3	-	-	9-225560-3	1-225343-0	9-227560-0	5225744-4					
8	OBSOLETE	1 2 3 4	-	225326-2	9-225325-0	1-331987-9	226719-2	9-225745-0	5225744-3					
	FOR USE WITH	6	SEAL QTY=1	5	FERRULE ARMOR QTY=1	4	FERRULE BRAID QTY=1	3	FERRULE QTY=1	2	CONTACT QTY=1	1	PLUG ASSY QTY=1	PART NUMBER

8	OBSOLETE	53.59 [2.110]	14.30 [.563]	7.92 [.312]	9.53 [.375]	5225744-4
		57.94 [2.281]	22.25 [.876]	12.70 [.500]	17.48 [.688]	5225744-3
		D	C	B	A	PART NUMBER

THIS DRAWING IS A CONTROLLED DOCUMENT.

DWN	J. ALCORTA - DOCK5	22APR2005	Tyco Electronics Corporation Harrisburg, PA 17105-3608		
CHK	J. HAVENER	22APR2005			
APVD	G. MICHAEL	22APR2005			
PRODUCT SPEC	108-12066				
APPLICATION SPEC	-		NAME	A1 PLUG, WEATHERPROOF, SERIES HN	
WEIGHT	-	SCALE	A2 00779	DRAWING NO	C=5225744
CUSTOMER DRAWING	SCALE		2:1	SHEET	1 of 1
				REV	A1