

C-MPO-4LC20M9SMFLZ

20m MPO (Female) to 8xLC (Male) 8-Strand Yellow OS2 LSZH Fiber Fanout Cable

Features

- Female MPO connector to Male 8xLC connectors
- 20m length
- LSZH Jacket
- Color: Yellow
- Factory terminated and tested
- Rapid deployment Factory terminated modular system saves installation and reconfiguration time during moves
- Reliability 100% tested – combination of high quality components and manufacturing quality control guarantees product to the highest standards

Product Description

This is a 20m MPO (female) to 8xLC (male) 8-strand yellow LSZH fiber fanout cable. OS2 is a standard single-mode optical fiber commonly used with wavelengths of 1310nm and 1550nm (9/125 microns), and has a maximum attenuation of 1dB/km. The OS2 standard is defined in ISO/IEC 11801. This optical fiber, nonconductive, LSZH cable is best suited for use in interior fiber-optic applications. Our patch cables are 100% compliant for all of your networking needs. Our products are guaranteed by federal law to not affect or void OEM warranties.

Specifications

Parameter	Specification
Fiber	OS2
Application	Fanout
Cable Mode	Multiple
Color	Yellow
Connectors	MPO (Female) to 8xLC (Male)
Core/Cladding	9/125 μ m
Fiber type	SMF
Jacket Type	LSZH
Length (ft)	65.62
Length (m)	20
Strand Count	8
Cable Length Tolerance	15cm

Mechanical Specifications

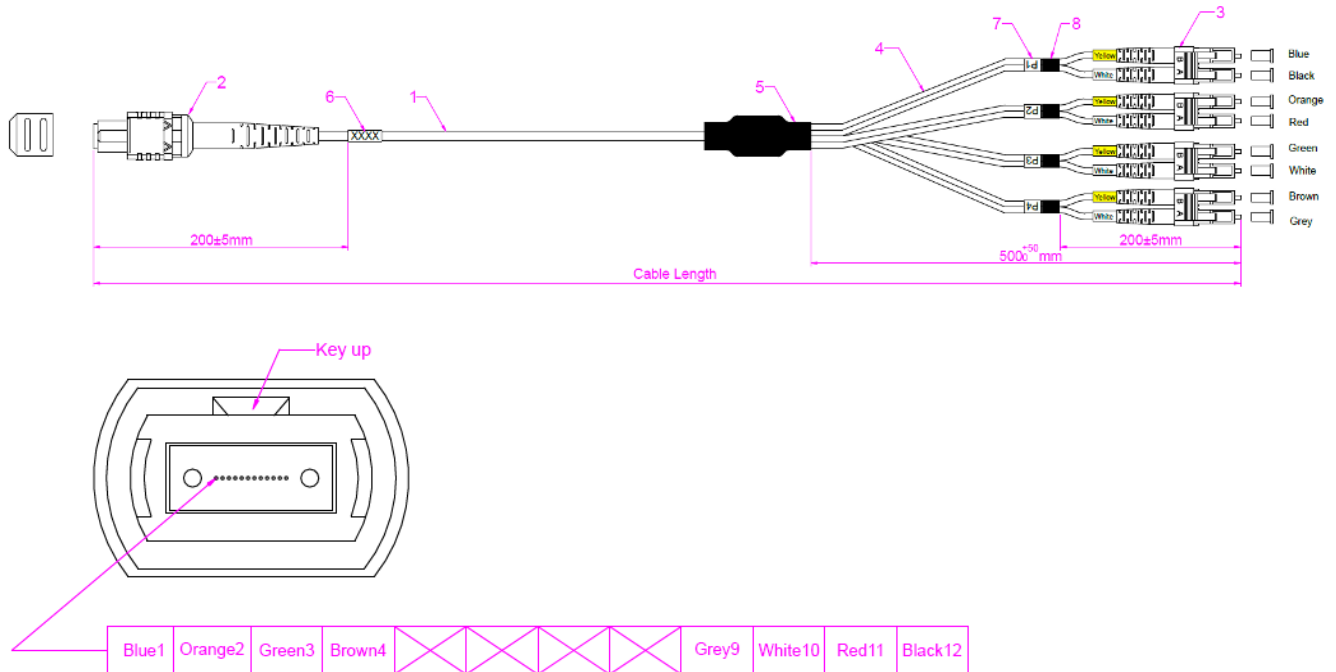

1	Ø3.0mm. Single Mode 9/125 G657A1/G652D 8 Fibers. Single Jacket. Micro Cable PVC/LSZH/OFNP Color:Yellow
2	MPO/APC Female. SM. 12F Connector. Green Housing. Black Boot.
3	LC/UPC SM. Duplex. 2.0mm Connector. Blue Housing. 19mm. Short White Boot.
4	OD: 2.0mm. Duplex. Color: Yellow. PVC/LSZH/OFNP.
5	Fanout Kit.
6	Serial Number Label.
7	Cable Marker.
8	Black Shrinkage Tube.

Notes:

1. Insertion Loss: MPO≤0.7dB; LC≤0.2dB.
2. Return Loss: MPO≥60dB; LC≥55dB.

About ProLabs

Our experience comes as standard; for over 15 years ProLabs has delivered optical connectivity solutions that give our customers freedom and choice through our ability to provide seamless interoperability. At the heart of our company is the ability to provide state-of-the-art optical transport and connectivity solutions that are compatible with over 90 optical switching and transport platforms.

Complete Portfolio of Network Solutions

ProLabs is focused on innovations in optical transport and connectivity. The combination of our knowledge of optics and networking equipment enables ProLabs to be your single source for optical transport and connectivity solutions from 100Mb to 400G while providing innovative solutions that increase network efficiency. We provide the optical connectivity expertise that is compatible with and enhances your switching and transport equipment.

Trusted Partner

Customer service is our number one value. ProLabs has invested in people, labs and manufacturing capacity to ensure that you get immediate answers to your questions and compatible product when needed. With Engineering and Manufacturing offices in the U.K. and U.S. augmented by field offices throughout the U.S., U.K. and Asia, ProLabs is able to be our customers best advocate 24 hours a day.

Contact Information

ProLabs US

Email: sales@prolabs.com

Telephone: 952-852-0252

ProLabs UK

Email: salesupport@prolabs.com

Telephone: +44 1285 719 600