

REVISIONS					
P	LTR	DESCRIPTION	DATE	DMN	APVD
A2		REVISED PER ECO-17-011927	22AUG2017	RS	KR

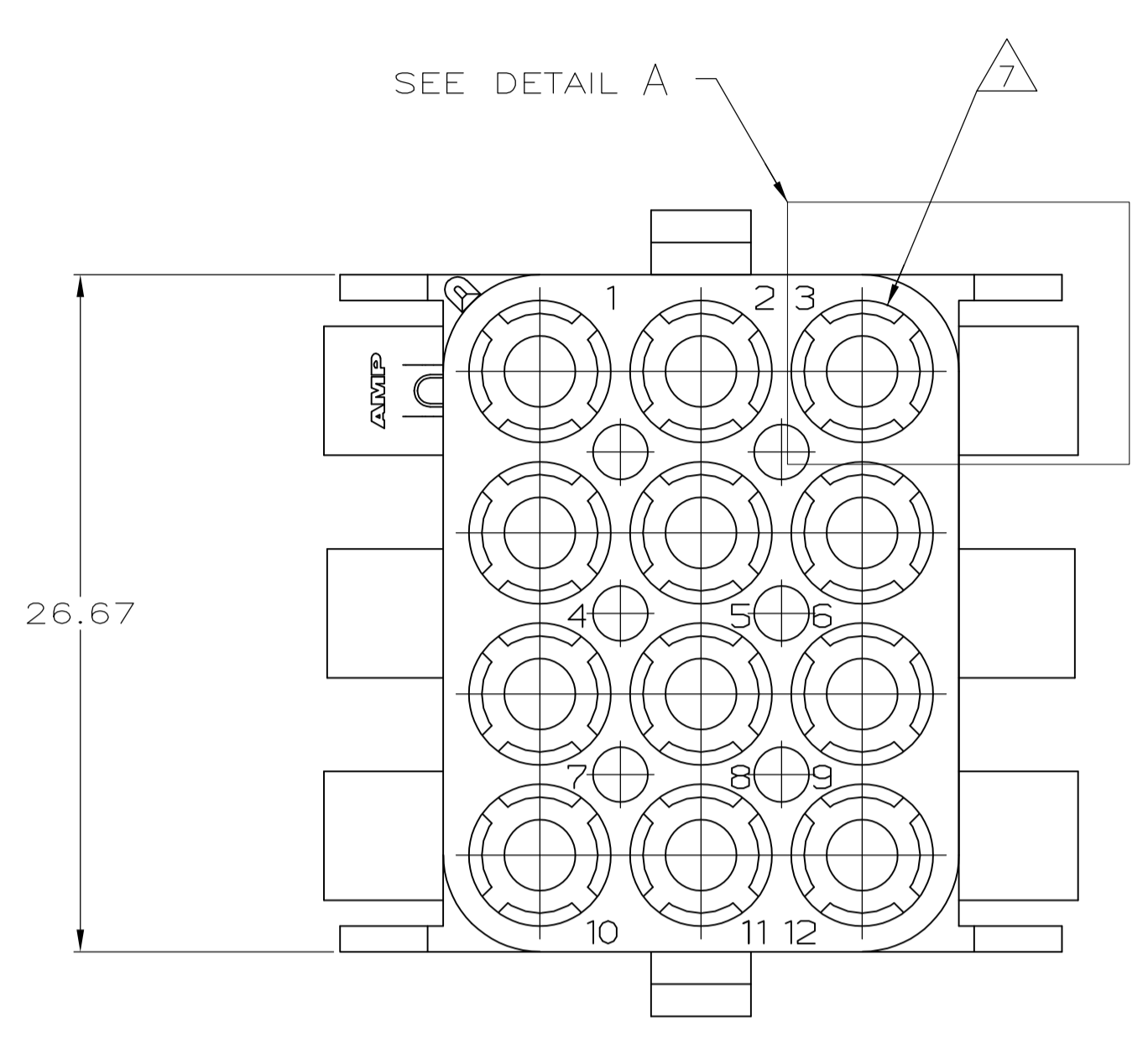

- 1 MATES WITH APPROPRIATE UNIVERSAL MATE-N-LOK™ PLUG.
- 2 RECOMMENDED PANEL THICKNESS 0.76 - 2.29.
- 3 PANEL MUST BE PUNCHED SO THAT THE HOUSING ENTERS THE PANEL IN THE SAME DIRECTION AS THE PUNCH.
- 4 OPTIONAL FOR KEYING HOUSING IN PANEL.
- 5 CIRCUIT NUMBER 1 LOCATION.
- 6 DIMENSIONS SHOWN REPRESENT PRODUCT IN DRY, AS MOLDED CONDITION ADDITIONAL 2% GROWTH DUE TO SUBSEQUENT MOISTURE ABSORPTION MAY OCCUR AND SHOULD BE ACCOUNTED FOR.
- 7 FOUR RIBS EQUALLY SPACED, NO SPECIFIC ORIENTATION. NO RIBS OR SIX RIBS EQUALLY SPACED, NO SPECIFIC ORIENTATION, OPTIONAL.
- 8 UNDERWRITERS RECOGNIZED COMPONENT LOGO AND CSA CERTIFICATION LOGO TO BE LOCATED ONCE EACH ON SIDE OF HOUSING.
- 9 150° C TEMPERATURE RATING FOR THIS HOUSING IS FOR SHORT TERM DURATION. MAX OPERATING TEMPERATURE REMAINS 125° C.
- 10 PHOSPHOR BRONZE CONTACTS SHOULD ALWAYS BE USED WITH THIS HOUSING.

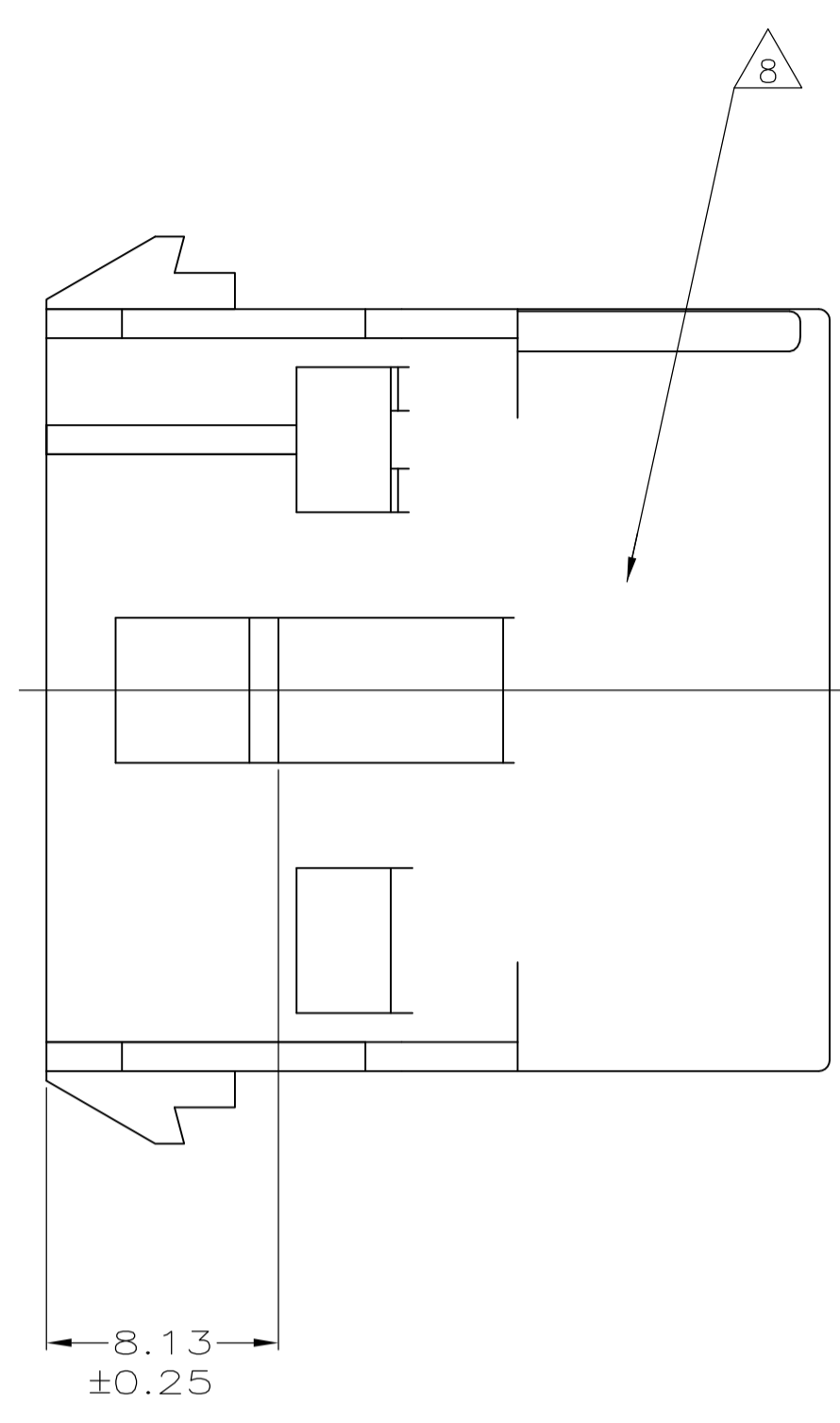
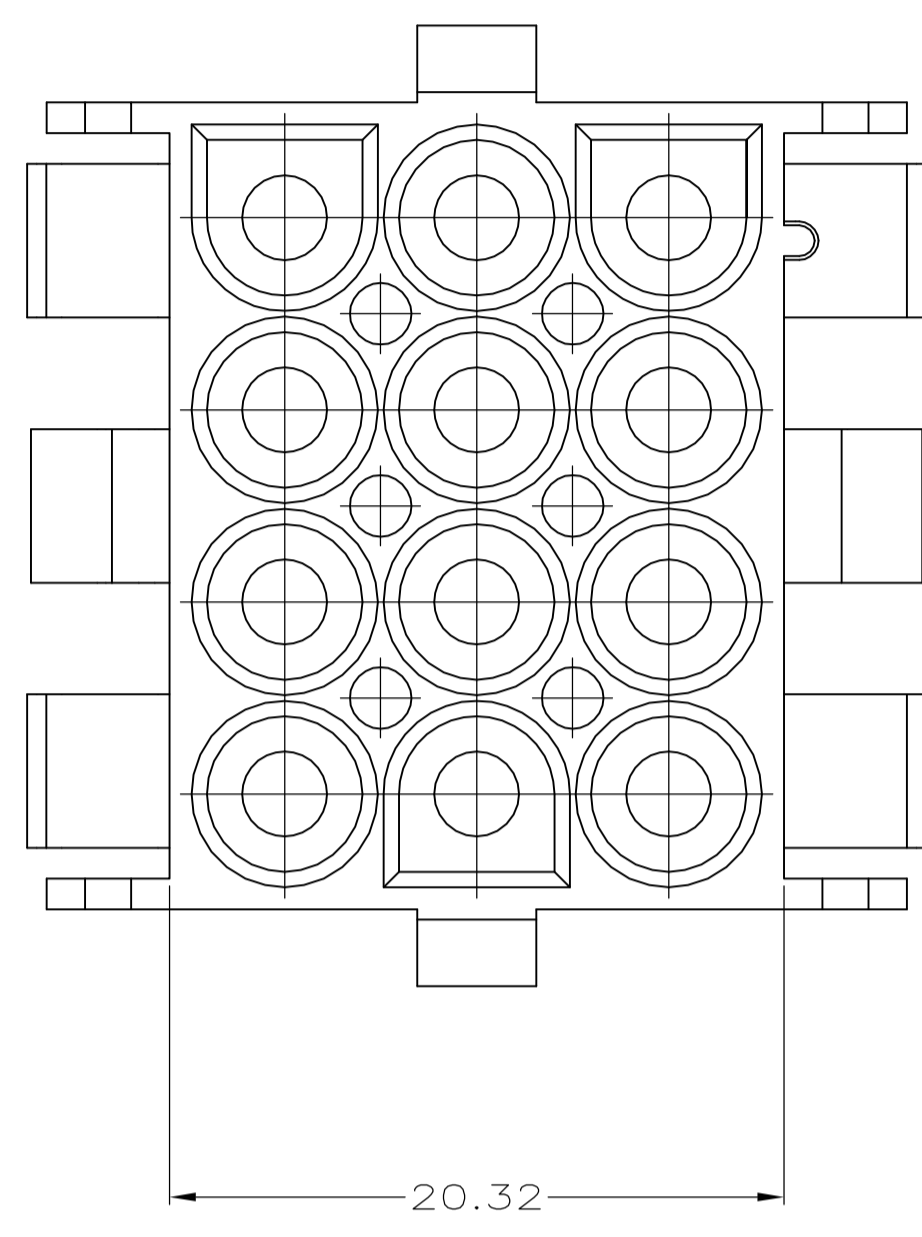
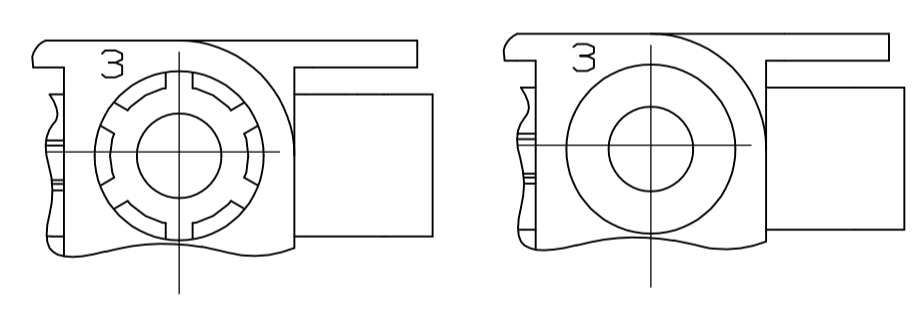

DETAIL A  
OPTIONAL CONSTRUCTION

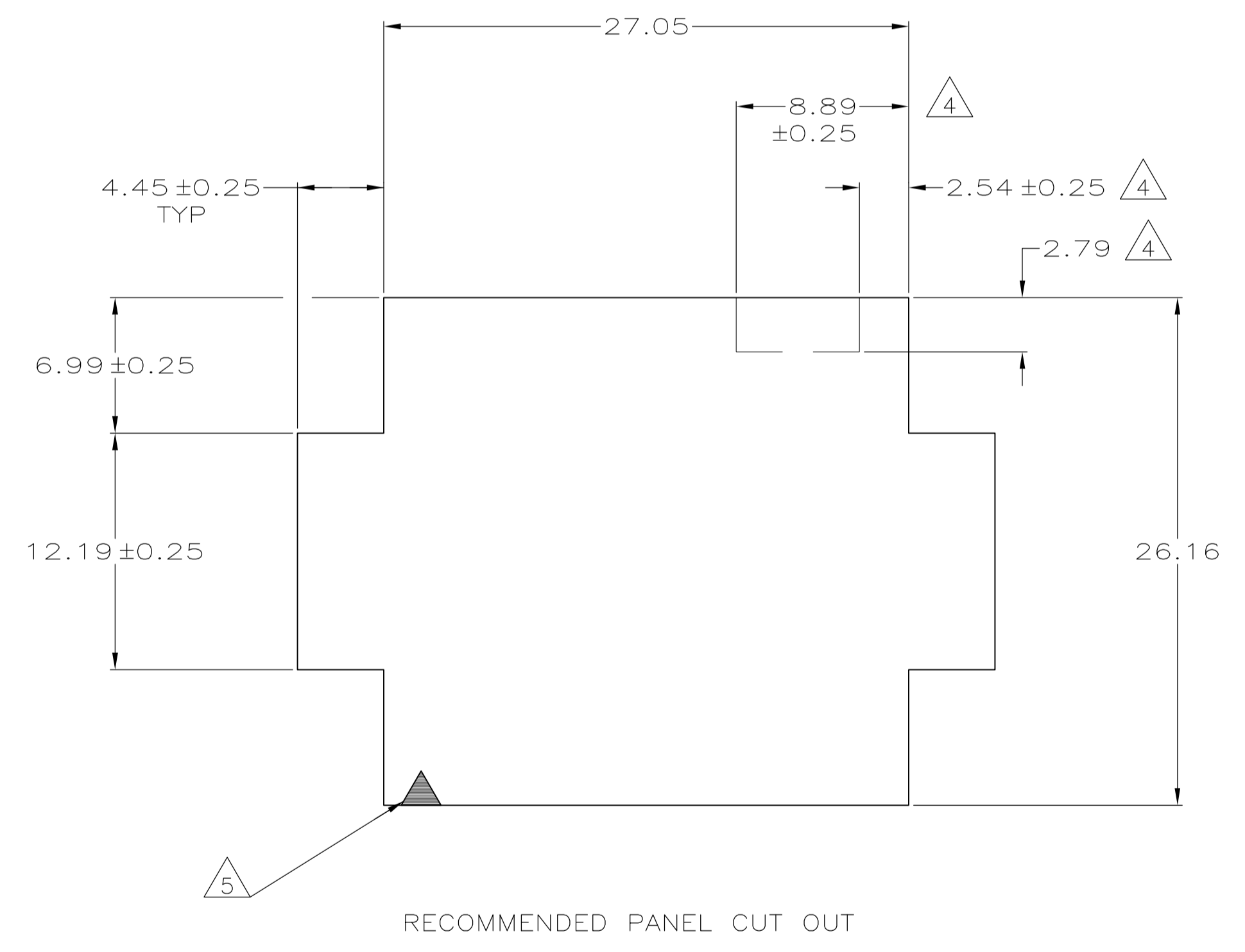
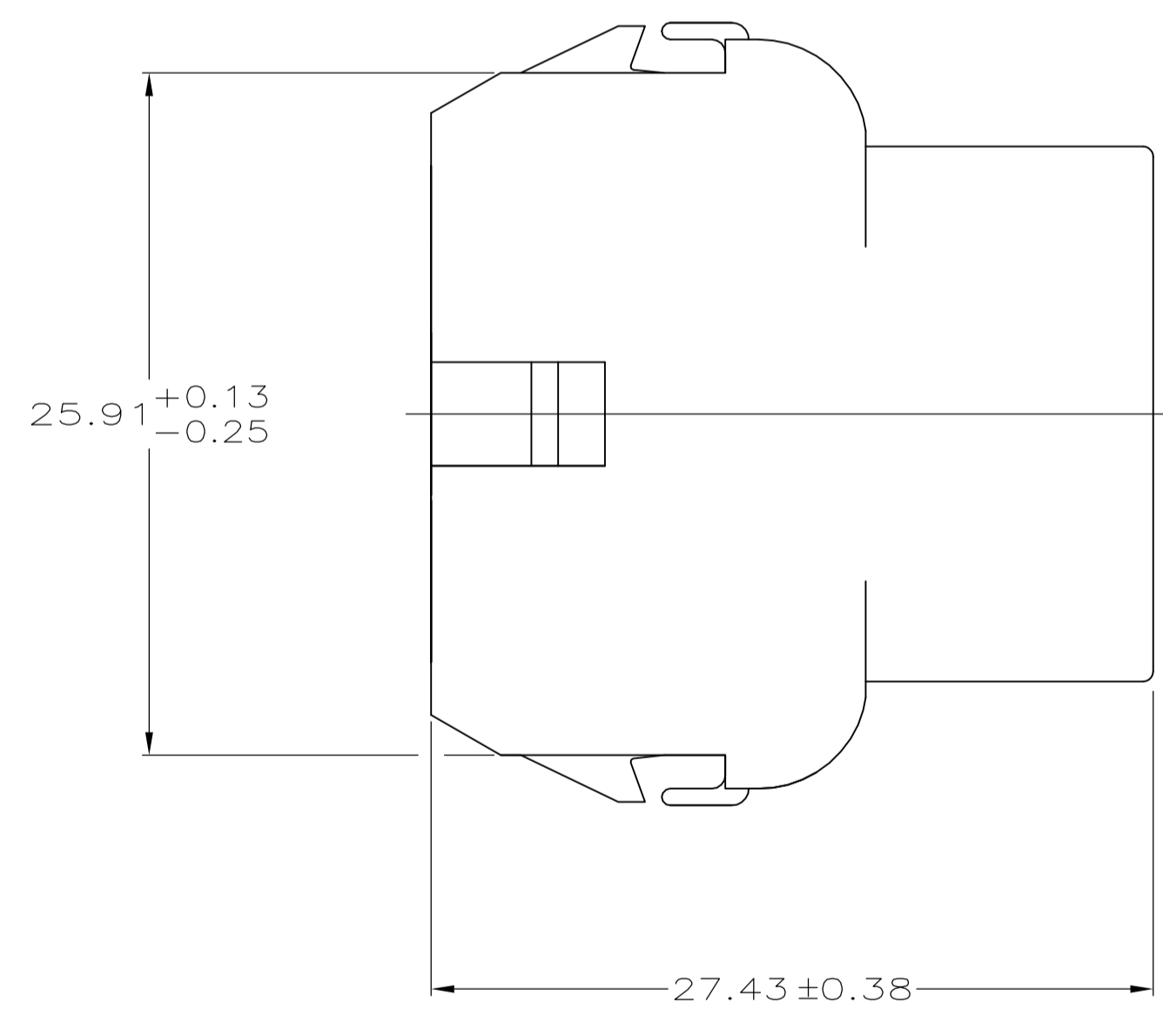

RECOMMENDED PANEL CUT OUT

6.99	.275	27.43	1.080
4.45	.175	27.05	1.065
2.79	.110	26.67	1.050
2.54	.100	26.16	1.030
2.29	.090	25.91	1.020
0.76	.030	20.32	.800
0.38	.015	12.19	.480
0.25	.010	8.89	.350
0.13	.005	8.13	.320
MM	IN	MM	IN

CONVERSION TABLE

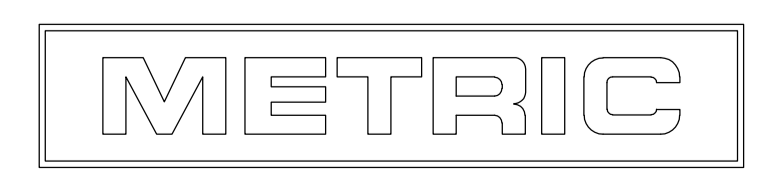

THIS DRAWING IS A CONTROLLED DOCUMENT.

DIMENSIONS: INCHES	TOLERANCES UNLESS OTHERWISE SPECIFIED:	DIN K. WHITAKER 5-28-92	CHK R. SWING 5-28-92	APVD D. SELF 6-2-92	NAME		
0. PLC ± -	1. PLC ± -	TE Connectivity			CAP,12 CIRCUIT, UNIVERSAL MATE-N-LOK™ TM		
2. PLC ± 0.13	3. PLC ± -						
4. PLC ± -	ANGLES ± 1° 0'						
MATERIAL NYLON,UL 94V-2, HIGH TEMP, BLACK						FINISH -	WEIGHT 0.000000
CUSTOMER DRAWING		SCALE 4:1	SHEET 1 OF 1	REV A2	794727-1	PART NO	