

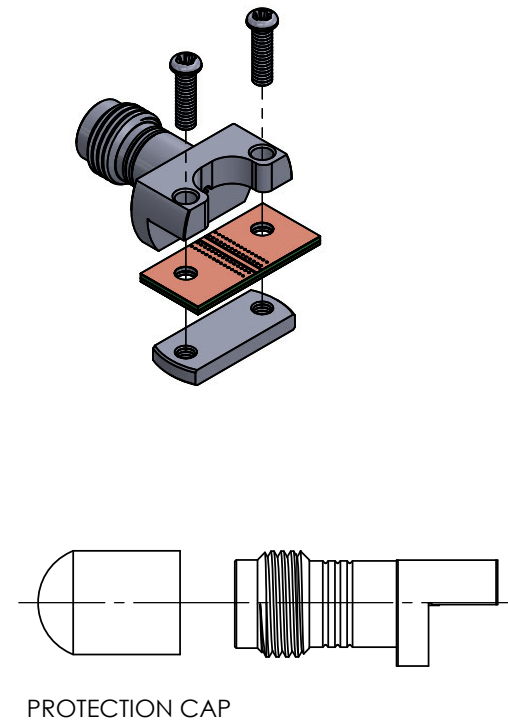

REVISIONS			
REV.	DESCRIPTION	DATE	APPROVED
-	INITIAL RELEASE	07/03/2018	MM
1	UPDATED PART NUMBER AND COLOR	10/26/2018	DL
2	ADDED SHEET 2 PCB DEFINITION	2/20/2019	PV
3	ADDED SECTION VIEW	3/7/2019	PV
4	REVISED MODEL	11/19/2019	PV

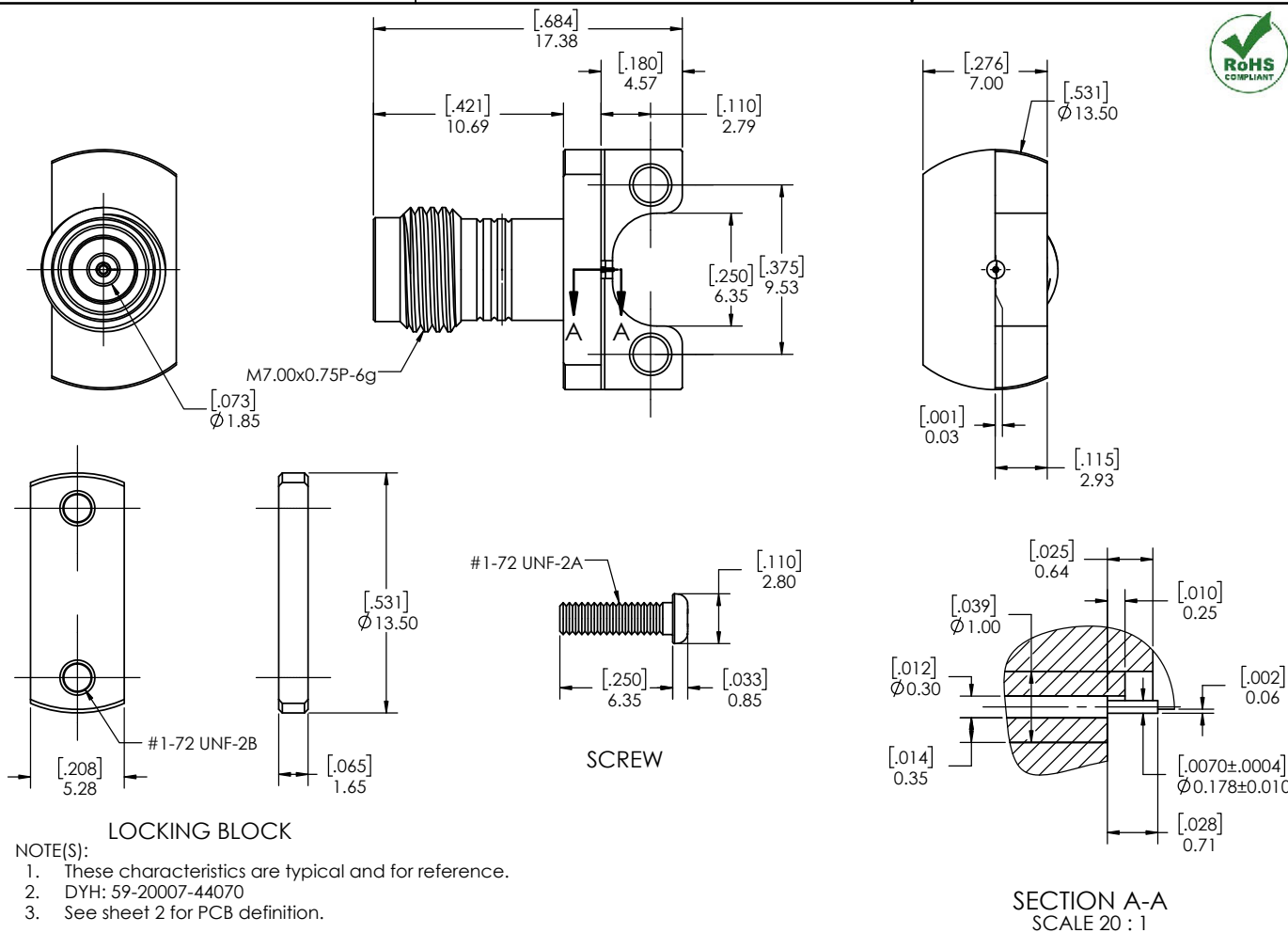

LOCKING BLOCK

NOTE(S):
 1. These characteristics are typical and for reference.
 2. DYH: 59-20007-44070
 3. See sheet 2 for PCB definition.

SECTION A-A
SCALE 20 : 1

PROTECTION CAP

MATERIAL(S) :	ELECTRICAL(S) :	MECHANICAL(S) :	ENVIRONMENTAL(S) :
Body: Stainless Steel Center Conductor: Beryllium Copper Insulator: Insulator 1: PCTFE, white Insulator 2: PTFE, white RoHS Compliant Protective Cap: Soft PVC Color: Green	Impedance: 50 Ohms Nominal Frequency Range: DC to 65 GHz VSWR: 1.3:1 max at 65 GHz Working Voltage: 400 Vrms max @ Sea Level Dielectric Withstand Voltage: 500 Vrms max. Insulation Resistance: 5000 Megohms min. Contact Resistance: Initial: Center Contact: 1.5 Milliohms max Outer Contact: 0.8 Milliohms max	Mating Characteristics: Interface per MIL-STD-348 Force to Engage & Disengage: Torque: 2 inch-pounds max Longitudinal Force: NA Connector Durability: 500 Cycles min. Permeability: Less than 2.0 mu. Center Contact Retention: Axial Force: 6 pounds min. Radial Force: NA	Temperature Range: -65°C to +165°C Moisture Resistance: MIL-STD-202, Method 103, Test Condition B Corrosion: MIL-STD-202, Method 101, Test Condition B Vibration: MIL-STD-202, Method 204, Test Condition A Shock: MIL-STD-202, Method 213, Test Condition 1

FINISH(ES) :
Body: Passivated Center Conductor: Gold Plating

APPLICABLE CARLISLE IT DOCUMENTS			TOLERANCES AND NOTES		APPROVAL	INITIALS	DATE
WORK STANDARD	PROD INSTRUC	ASSY INSTRUC	EXCEPT AS NOTED		DRAWN BY		
NA	NA	NA	THIRD ANGLE PROJECTION		MM		07.03.18
NOTICE THIS DRAWING EMBODIES A CONFIDENTIAL PROPRIETARY DESIGN ORIGINATED BY CARLISLE INTERCONNECT TECHNOLOGIES & ALL DESIGN, MANUFACTURING, REPRODUCTION, USE & SALE RIGHTS REGARDING THE SAME ARE EXPRESSLY RESERVED. IT IS LIMITED UNDER A CONFIDENTIAL RELATIONSHIP FOR A SPECIFIED PURPOSE & THE RECIPIENT AGREES BY ACCEPTING THIS DRAWING NOT SUPPLY OR DISCLOSE ANY INFORMATION REGARDING IT TO ANY UNAUTHORIZED PERSON TO INCORPORATE IN OTHER PROJECTS ANY SPECIAL FEATURES PECULIAR TO THIS DESIGN. ALL PATENT RIGHTS HERETO ARE EXPRESSLY RESERVED BY CARLISLE INTERCONNECT TECHNOLOGIES, GERRITOS, CALIFORNIA 90703			SCALE 5:1		CHECKED BY		07.03.18
			DIMENSIONS ARE IN [INCHES] MM		DESIGN ENG		
			ANGLES ±2°		APPR BY		
			.XX DECIMALS ±.063				
			.XXX DECIMALS ±.01				

TITLE
1.85mm STRAIGHT JACK, EDGE MOUNT (SOLDERLESS)

SCALE	SUB-DIRECTORY/	SHEET	OF	REV.
5:1	OUTLINE/	1	2	2

DRAWING NO.
C **TMB-E8F2-1L1**

4

3

2

1

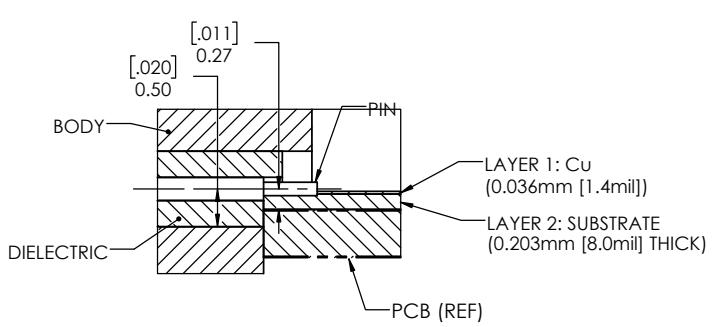
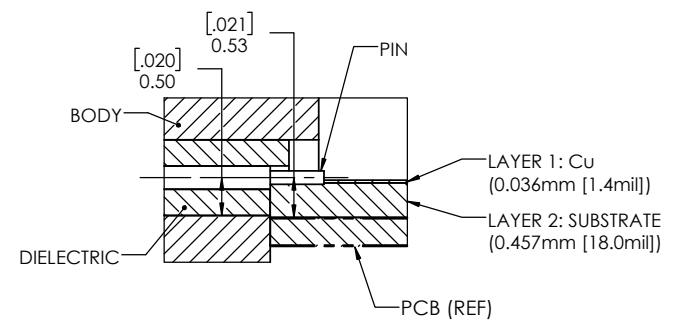
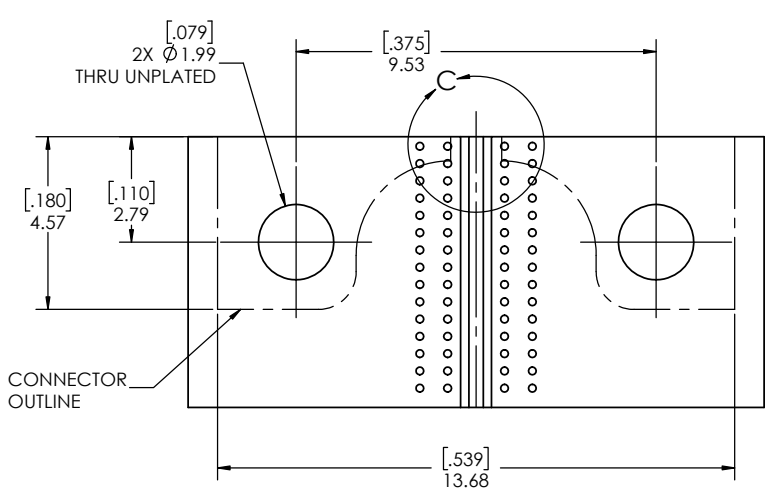
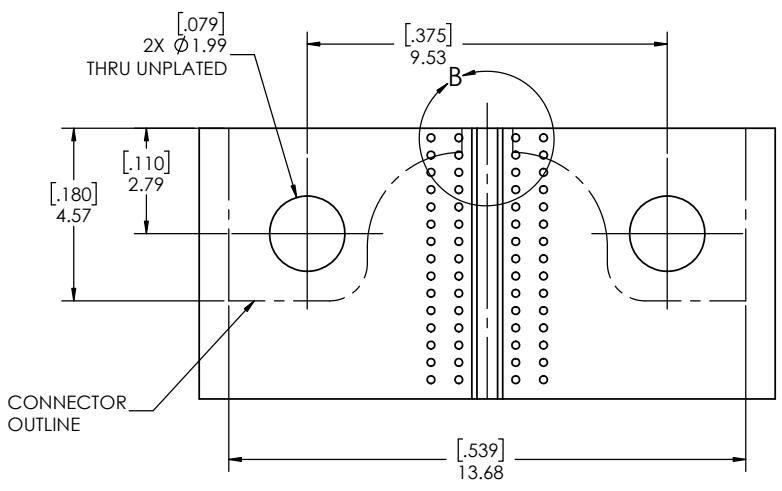
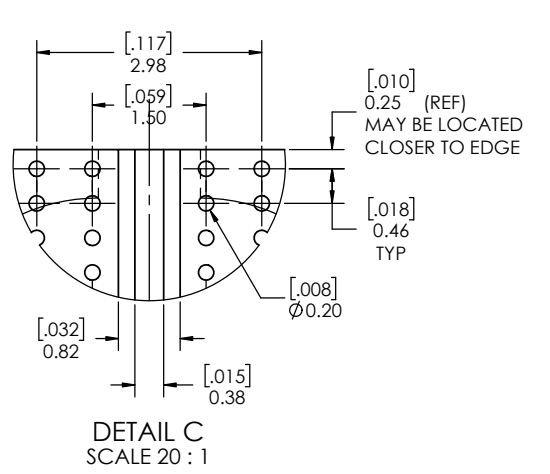
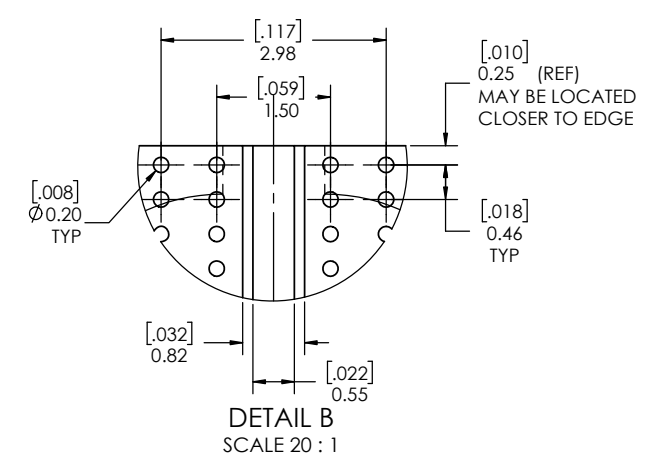

**PCB LAYOUT
(FOR REFERENCE ONLY)**

SCALE	SUB-DIRECTORY/	SHEET 2 OF 2
10:1		
SIZE	CAGE CODE	DRAWING NO.
C		TMB-E8F2-1L1
		REV. 4

4

3

2

1