

Industrial digital output expansion board based on IPS2050H for STM32 Nucleo

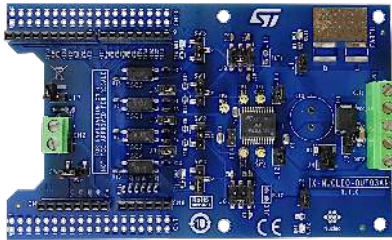

Features

- Based on **IPS2050H** dual high-side switch, which features:
 - Operating range up to 60 V/2.5 A
 - Low power dissipation ($R_{ON(MAX)} = 50\text{ m}\Omega$)
 - Fast decay for inductive loads
 - Smart driving of capacitive load
 - Under-voltage lock-out
 - Per-channel overload and over-temperature protection
 - PSSO24 package
- Application board operating range: 8 to 33 V/0 to 2.5 A
- Extended voltage operating range (J3 open) up to 60 V
- Green LEDs for output on/off status
- Red LEDs for per-channel diagnostic (overload and overheating)
- 5 kV galvanic isolation
- Supply rail reverse polarity protection
- EMC compliance with IEC61000-4-2, IEC61000-4-3, IEC61000-4-5
- Compatible with **STM32 Nucleo** development boards
- Equipped with Arduino UNO R3 connectors
- CE certified
- RoHS and China RoHS compliant

Product summary	
Industrial digital output expansion board based on IPS2050H for STM32 Nucleo	X-NUCLEO-OUT03A1
Industrial digital output software expansion for STM32Cube	X-CUBE-OUT3
Dual high-side smart power solid state relay	IPS2050H
Applications	Programmable Logic Controllers

Description

The **X-NUCLEO-OUT03A1** industrial digital output expansion board for **STM32 Nucleo** provides a powerful and flexible environment for the evaluation of the driving and diagnostic capabilities of the **IPS2050H** (dual high-side smart power solid state relay) in a digital output module connected to 2.5 A (max.) industrial loads.

The **X-NUCLEO-OUT03A1** interfaces with the microcontroller on the **STM32 Nucleo** via 5 kV optocouplers driven by GPIO pins, Arduino UNO R3 (default configuration) and ST morpho (optional, not mounted) connectors.

The expansion board can be connected to either a **NUCLEO-F401RE** or **NUCLEO-G431RB** development board.

It is also possible to evaluate a system composed by up to four stacked **X-NUCLEO-OUT03A1** expansion boards.

As an example, a system with four **X-NUCLEO-OUT03A1** expansion boards allows you to evaluate an eight-channel digital output module with 2.5 A (max.) capability each.

1 Schematic diagrams

Figure 1. X-NUCLEO-OUT03A1 circuit schematic (1 of 2)

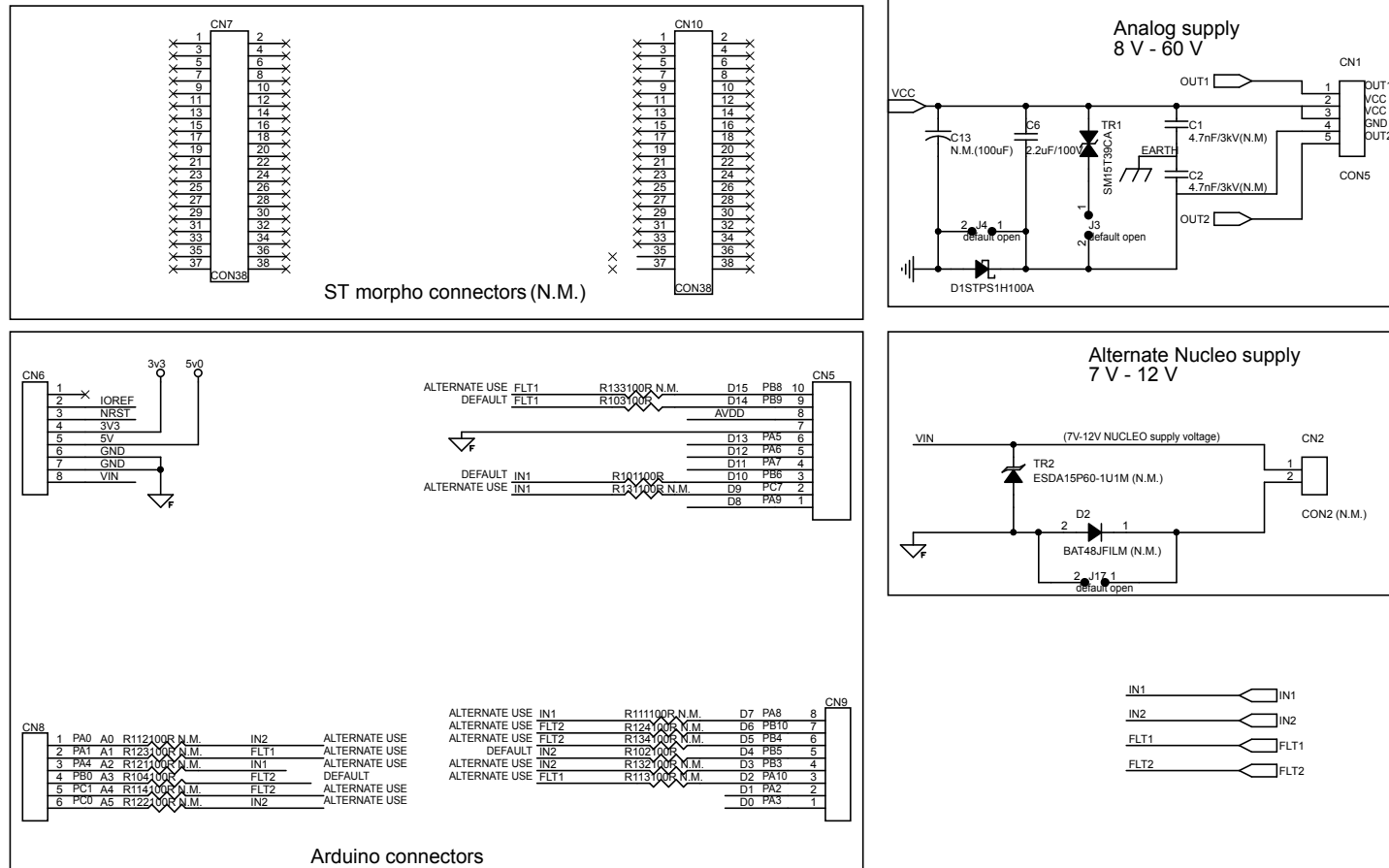
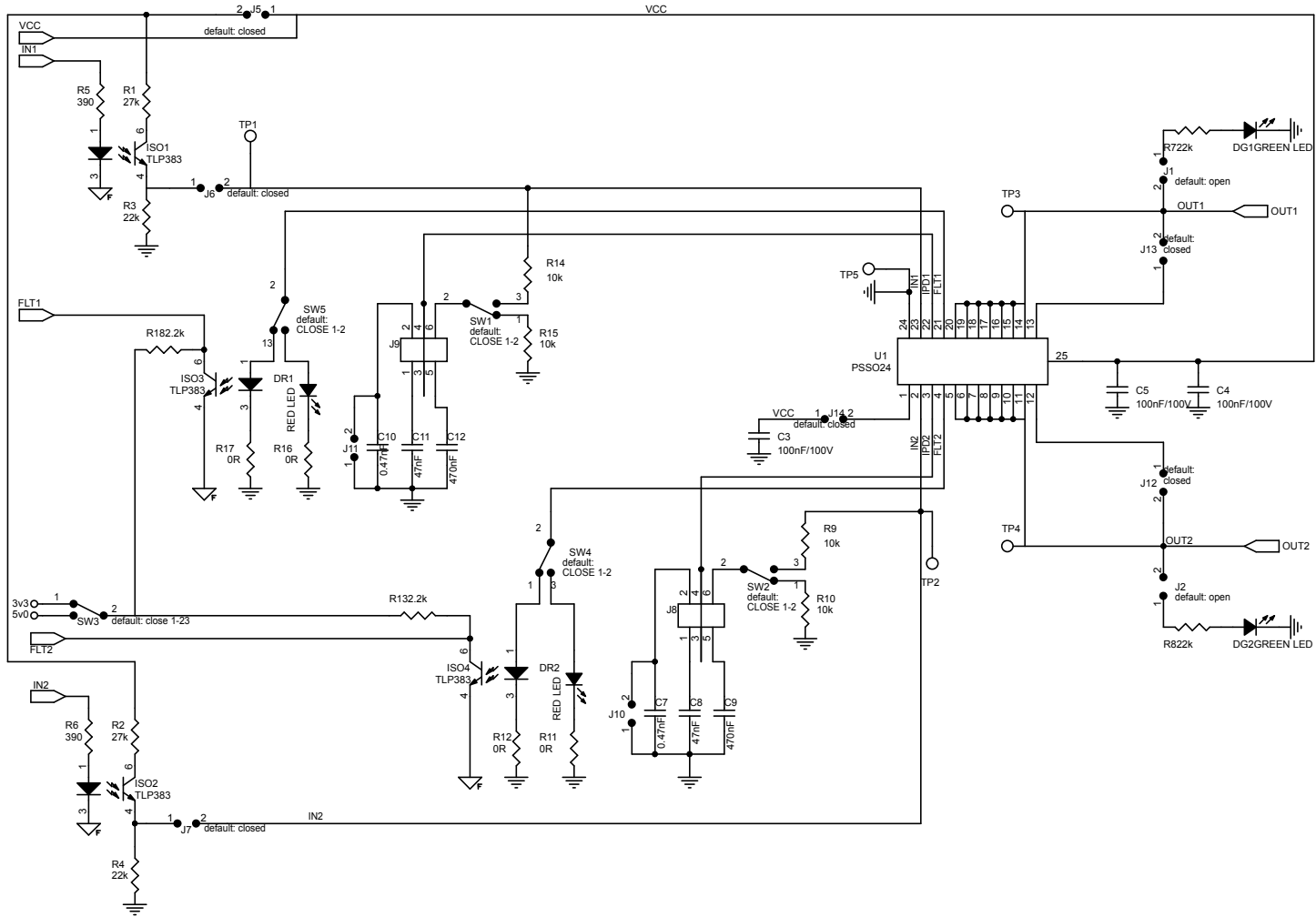

Figure 2. X-NUCLEO-OUT03A1 circuit schematic (2 of 2)



Revision history

Table 1. Document revision history

Date	Version	Changes
04-Aug-2021	1	Initial release.

IMPORTANT NOTICE – PLEASE READ CAREFULLY

STMicroelectronics NV and its subsidiaries (“ST”) reserve the right to make changes, corrections, enhancements, modifications, and improvements to ST products and/or to this document at any time without notice. Purchasers should obtain the latest relevant information on ST products before placing orders. ST products are sold pursuant to ST’s terms and conditions of sale in place at the time of order acknowledgement.

Purchasers are solely responsible for the choice, selection, and use of ST products and ST assumes no liability for application assistance or the design of Purchasers’ products.

No license, express or implied, to any intellectual property right is granted by ST herein.

Resale of ST products with provisions different from the information set forth herein shall void any warranty granted by ST for such product.

ST and the ST logo are trademarks of ST. For additional information about ST trademarks, please refer to www.st.com/trademarks. All other product or service names are the property of their respective owners.

Information in this document supersedes and replaces information previously supplied in any prior versions of this document.

© 2021 STMicroelectronics – All rights reserved