



## LatticeECP3™ Video Protocol Board – Revision C

---

### User's Guide

## Introduction

The LatticeECP3™ FPGA family includes many features for video applications. For example, DisplayPort, SMPTE standards (SD-SDI, HD-SDI and 3G-SDI), DVB-ASI, DVI and HDMI can be implemented with 16 channels of embedded SERDES/PCS. 7:1 LVDS video interfaces like ChannelLink and CameraLink can be supported by the generic DDRX2 mode on the I/O pins. When configuring to TRILVDS mode, the I/O pins on banks 0 and 1 can also be used to receive the TMDS signals of DVI or HDMI video standard.

This user's guide describes revision C of the LatticeECP3 Video Protocol Board featuring the LatticeECP3 LFE3-95E-7FN1156C FPGA device. The stand-alone evaluation PCB provides a functional platform for development and rapid prototyping of many different video applications.

**Figure 1. LatticeECP3 Video Protocol Board – Revision C**

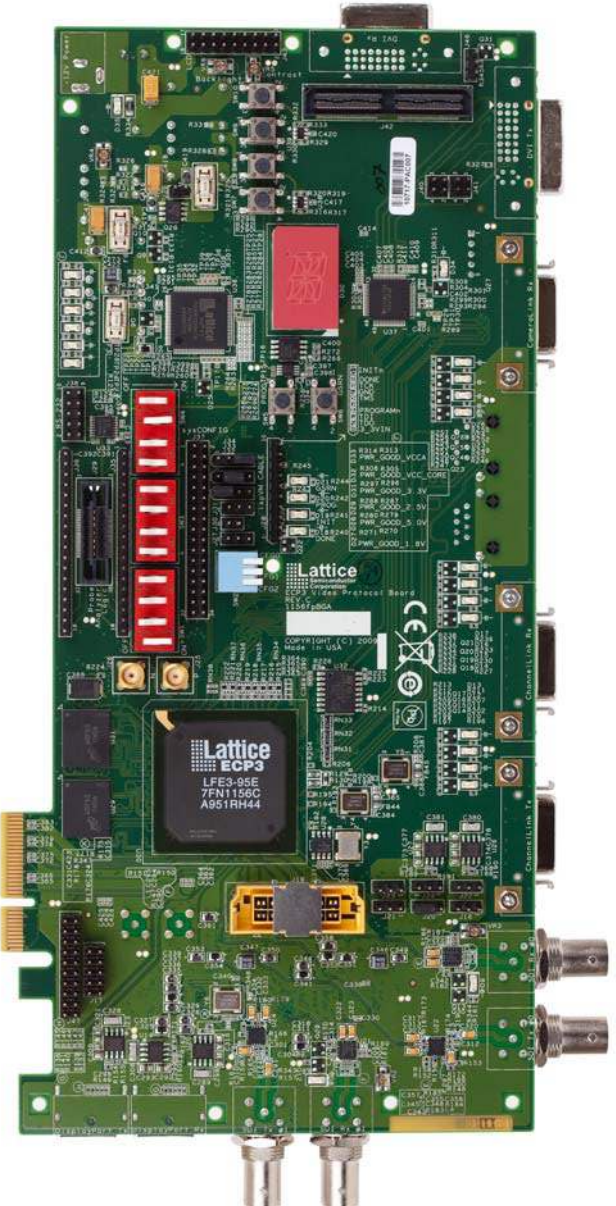

## Features

- Video interfaces for interconnection to video standard equipment
- Allow the demonstration of SD/HD/3G-SDI, DisplayPort and PCI Express (x4) interfaces using SERDES channels
- High speed Mezzanine connector connected to SERDES channels for future expansion
- Allows the demonstration of LVDS video standards – ChannelLink and CameraLink
- Allows control of SERDES PCS registers using the Serial Client Interface (ORCAstra)
- Allows the demonstration of receiving TMDS signals using the DVI interface
- On-board Boot Flash with Serial SPI Flash memory device
- Shows interoperation with high performance DDR2 memory components
- Driver-based “run-time” device configuration capability via an ORCAstra or RS232 interface
- SMAs for external high-speed clock / PLL inputs
- Switches, LEDs and LCD display header for demo purposes
- Micror connector for using Logic Analyzer in the debugging phase



2. The Revision C board includes eight pull-up resistors, R370-R377, to the DDR2 memory’s DQS signals. These resistors are placed close to the LatticeECP3 device. These resistors are not included on the Revision B board.
3. The Revision C board includes R75 between the P and N reference clocks of SERDES Quad C (Mezzanine daughter board) for future use. No resistor is populated. This resistor is not included on the Revision B board.
4. On the Revision C board, the Gennum clock generators (GS4911) on U2 and U3 are not populated.

### LatticeECP3 Device

This board features a LatticeECP3 FPGA with a 1.2V core supply. It can accommodate all pin compatible LatticeECP3 devices in the 1156-ball fpBGA (1mm pitch) package. A complete description of this device can be found in the [LatticeECP3 Family Data Sheet](#).

### Applying Power to the Board

The LatticeECP3 Video Protocol Board is ready to power on. This board can be supplied with power from an AC wall-type transformer power supply shipped with the board. Or it can be supplied from a bench top supply via terminal screw connections. It also has provisions to be supplied from the PCI Express edge fingers from a host board.

To supply power from the factory-supplied wall transformer, simply connect the output connection of the power cord to J15 and plug wall-transformer into an AC wall outlet.

### Supply Power from Bench Power Supply

The evaluation board incorporates an alternate scheme to provide power to the board. The board is equipped to accept a main supply via the TB1 connection. This connection is intended to be used with a bench top supply adjusted to provide a nominal 12V DC.

All input power sources and on-board power supplies are fused with surface mounted fuses. Table 1 shows these fuses and the corresponding powers.

**Table 1. Board Power Supply Fuses**

Fuse #	Rating	Voltage	Usage
F1	3A	2.5V	EEPROM, DDR2 regulator, Bank 1, 2 and 3 I/Os, DIP switches
F2	3A	1.8V	Bank 6, Bank 7 I/Os, DDR2 regulator, DDR2 memory, Gennum clock chips
F3	3A	5.0V	Cable driver/levelizer power regulator, Gennum clock chips power regulators, Display/Port power output regulators, Mezzanine connector, DVI power output for EDID, LCD module
F4	3A	1.2V	LatticeECP3 SERDES
F5	10A	12V	Main power supply
F6	10A	1.2V	LatticeECP3 Core
F7	10A	3.3V	LatticeECP3 V <sub>CC</sub> AUX: PLL, JTAG, Bank 0 and 8 I/Os, SPI Flash memory, push-button debouncer, DVI transmitter, RS-232 driver/receiver, zero delay clock buffer, clock oscillators, MachXO™, cable driver/levelizer

The Lattice ispPAC® Power Manager II device, the ispPAC-POWER1220AT8, is used for monitoring various voltages on the board. There are six LEDs used to indicate the status of the monitoring voltages. If the monitoring voltage is not in the +/- 5% voltage window, the corresponding LED will flash; otherwise, the LED will stay ON. Table 2 shows these six voltages and the corresponding LEDs.

**Table 2. Board Power Supply Monitoring Indicators**

Power	LED #	Voltage Range	In Range	Out of Range
LatticeECP3 SERDES	D33	1.2V +/- 5%	On	Flash
LatticeECP3 Core	D32	1.2V +/- 5%	On	Flash
3.3V	D31	3.3V +/- 5%	On	Flash
2.5V	D29	2.5V +/- 5%	On	Flash
5.0V	D28	5.0V +/- 5%	On	Flash
1.8V	D27	1.8V +/- 5%	On	Flash

External power can be alternatively connected through TB1 rather than the wall transformer power pack.

**Table 3. Board Supply Disconnects**

TB1	Screw terminal for 12V DC +12V: Pin1 (closer to the wall transformer power jack J15) 12V DC GND: Pin2 (closer to the LCD connector)
-----	---

### PCI Express Power Interface

Power can be sourced to the board via the PCB edge-finger (CN1). This interface allows the user to provide power from a PCI Express host board.

### Configuration/Programming Headers

Two programming headers are provided on the board for accessing to the LatticeECP3 JTAG port and sysCONFIG™ port. The JTAG connector is a 1x10 header and the sysCONFIG connector is a 2x17 header.

**Table 4. sysCONFIG Connector Pinout (J37)**

Net Name	LatticeECP3 Pin	Header Pin	Net Name	LatticeECP3 Pin	Header Pin
CCLK	C34	1	GND	—	2
SISPI	F33	3	D6	J34	4
CSSPION	D34	5	3.3V	—	6
CSSP1N	E34	7	INITN	C33	8
DONE	G31	9	PROGRAMN	B34	10
D7	F32	11	GND	—	12
D6	J34	13	GND	—	14
D5	H34	15	GND	—	16
D4	G32	17	GND	—	18
D3	G33	19	GND	—	20
D2	H33	21	GND	—	22
D1	G34	23	GND	—	24
D0	E32	25	GND	—	26
CSN	F31	27	WRITE	E31	28
CS1	G30	29	CFG0	B33	30
3.3V	—	31	CFG1	F30	32
GND	—	33	CFG2	D32	34

J28 is a 10-pin JTAG connector used in conjunction with the ispVM download cable to program and control the Lattice devices on this board.

Table 5. ispVM JTAG Connector (J28)

Pin #	Description
Pin 1	VCC
Pin 2	TDO
Pin 3	TDI
Pin 4	PROGRAMN
Pin 5	NC
Pin 6	TMS
Pin 7	GND
Pin 8	TCK
Pin 9	DONE
Pin 10	INITN

This board includes three Lattice programmable devices that can be programmed in a daisy chain (U30 = LatticeECP3-95, U1 = MachXO™ LCMXO256, and U36 = ispPAC-POWER1220AT8). Other than the LatticeECP3-95, the JTAG connector provides access to the JTAG ports of the ispPAC-POWER1220AT8 and the MachXO. With proper jumper selection, the JTAG ports of these devices can be chained together for programming. Table 6 shows the jumper settings of J32, J33 and J34 used to configure the JTAG connections.

Table 6. JTAG Connection Settings (J32, J33, J34)

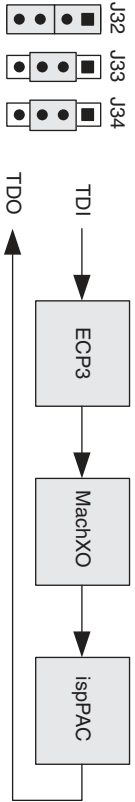
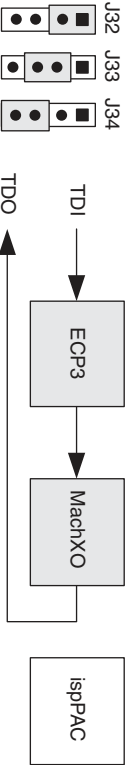
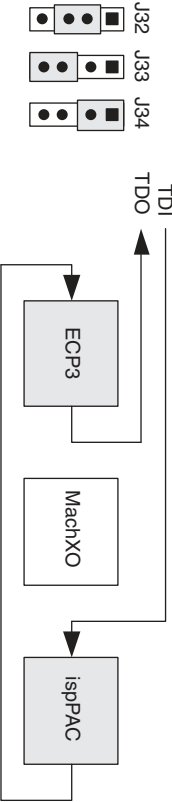
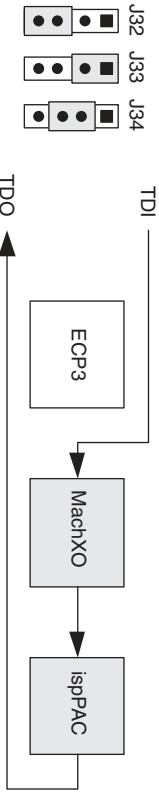
Jumper Settings	JTAG Connection
1	
2	
3	
4	

**Table 6. JTAG Connection Settings (J32, J33, J34) (Continued)**

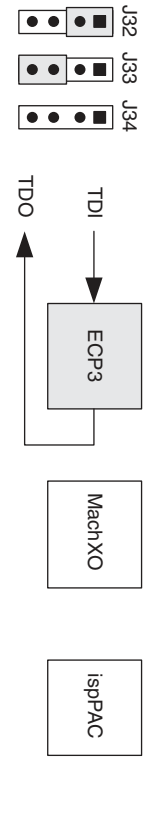
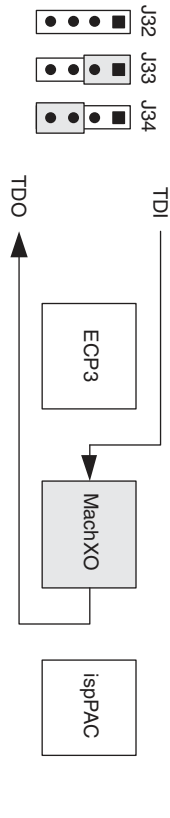
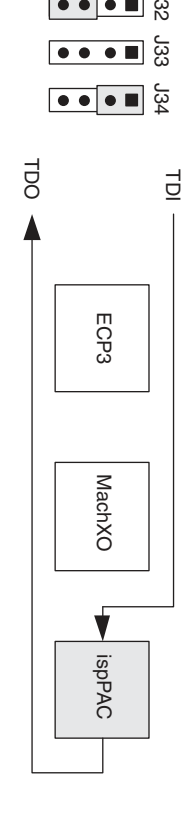
Jumper Settings	JTAG Connection
5	
6	
7	

There are several LEDs on the board to indicate the LatticeECP3 programming status. They are listed in Table 7.

**Table 7. LED Indicators for Configuration Status**

LED #	Color	Function
D19	Red	LED illuminated to indicate that the programming was aborted or reinitialized driving the INITN output low.
D18	Green	LED illuminated to indicate the successful completion of configuration by releasing the open collector DONE output pin.
D20	Red	LED illuminated to indicate that PROGRAMN is low.
D21	Red	LED illuminated to indicate that GSRN is low.

The PROGRAMN pin of the LatticeECP3-95 is connected to a push-button switch (SW5). Depressing this button drives a logic level “0” to the PROGRAMN pin. This will force the LatticeECP3 into the configuration mode and initiate the configuration sequence.

The FPGA CFG pins are set on the board for a particular programming mode via the SW2 DIP switch. JTAG programming is independent of the MODE pins and is always available to the user. Pushing down the switch will turn it on and set the CFG value to 0.

**Table 8. CFG Mode Selections**

CFG2 (SW2-1)	CFG1 (SW2-2)	CFG0 (SW2-3)	Selected Configuration Mode
0 (ON)	0 (ON)	0 (ON)	SPI Flash Mode (available on-board)
0 (ON)	1 (OFF)	0 (ON)	SPIm
1 (OFF)	0 (ON)	0 (ON)	Master Serial
1 (OFF)	0 (ON)	1 (OFF)	Slave Serial
1 (OFF)	1 (OFF)	0 (ON)	Master Parallel
1 (OFF)	1 (OFF)	1 (OFF)	Slave Parallel

## On-Board Flash Memory

One SPI (16-pin TSSOP 64M) Flash memory device (U32) is on board for non-volatile configuration memory storage. The CFG [2:0] setting must be [000] for the LatticeECP3 to enable the SPI Flash mode.

## Video Clock Management and SDI Cable Driver/Equalizer

Industry standard video clocks are generated and managed via Gennum chipsets. These chipsets are used to generate both transmit and receive reference clocks for LatticeECP3 SERDES. The GS4911 clock generator device produces multiple video standard reference clocks from an on-board 27MHz crystal. The GS4915 clock cleaner is used to reduce clock jitter to produce a clean clock for video signal quality using a high-performance VCO. The Gennum clock devices are used to generate clocks for SD/HD/3G-SDI applications. Since the PLL in LatticeECP3 FPGAs is designed to support all the frequencies required by SD/HD/3G-SDI, the GS4911 clock generator is no longer needed. The two GS4911 devices found on the Revision B board are included on the Revision C board but not populated.

Two cable drivers and two cable equalizers are placed on-board for SD/HD/3G-SDI applications that require delivering video signal over 75 ohm coaxial cable.

The control and status pins of the Gennum chipsets and the cable drivers/equalizers are connected to the MachXO I/O pins. By using the signals connected between the MachXO and LatticeECP3, the Gennum chipsets and cable drivers/equalizers can be controlled from the design in the LatticeECP3. Figure 3 shows the block diagram of the control/status buses of the connections between these devices. The MachXO pins connected to these devices are shown in Tables 9 to 12.

**Figure 3. Block Diagram of Gennum Chipsets and Cable Driver/Equalizer Controls**

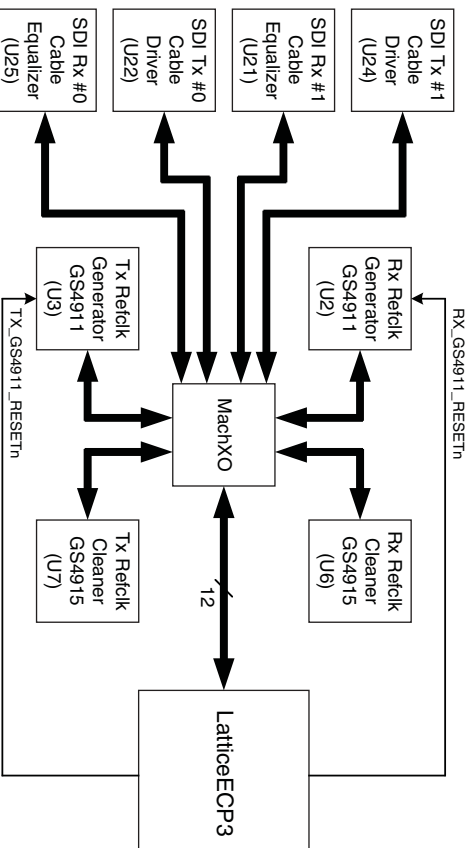



**Table 9. MachXO Pin Connections to GS4911 Devices (GS4911 Devices are Not Populated on the Revision C Board)**

Signal Type	GS4911 Pin Name	U2 (for Rx Refclk)	U3 (for Tx Refclk)	Pull-low/high
Control	VID_STD0	K2	G13	High
	VID_STD1	L1	H13	Low
	VID_STD2	L2	J13	High
	VID_STD3	M1	J14	Low
	VID_STD4	M2	K13	High
	VID_STD5	N1	K14	Low
	/GENLOCK	M3	M13	High
	ASR_SEL0	H2	—	Low
	ASR_SEL1	G2	—	Low
	ASR_SEL2	F2	—	Low
	JTAG / HOSTn <sup>1</sup>	N11	N11	—
	SCLK_TCLK <sup>1</sup>	P13	P13	—
	SDIN_TDI	—	N12	—
	SDOUT_TDO	P12	—	—
	Csn_TMS	P11	P14	—
Status	/RESET	D17 (from LatticeECP3)	D12 (from LatticeECP3)	Low
	LOCK_LOST	—	L14	—
	REF_LOST	—	L13	—
	TIMING_OUT_1	K1	F14	—
	TIMING_OUT_2	J2	F13	—
	TIMING_OUT_3	J1	E14	—
	TIMING_OUT_4	—	E13	—

1. These are the signals controlled by the same MachXO I/O pins.

**Table 10. MachXO Pin Connections to GS4915 Devices**

Signal Type	GS4915 Pin Name	U6 (for Rx Refclk)	U7 (for Tx Refclk)	Pull-low/high	
Control	/RESET	F1	D14	High	
	IPSEL	E2	D13	Low	
	BYPASS	E1	C14	Low	
	/AUTOBYPASS	C2	C13	Low	
	FCTRL0	D1	B14	Low	
	FCTRL1	D2	C12	Low	
	DOUBLE	C1	A13	Low	
	SKEW_EN	B1	A12	Low	
	Status	LOCK	B11	B12	—

**Table 11. MachXO Pin Connections to LMH0303 or GS2978 Cable Driver Devices**

Signal Type	Driver Pin Name	U22 (for Tx #0)	U24 (for Tx #1)	Pull-low/high
Control	SD / HDn	N5	N14	Low
	ENABLE (/DISABLE)	N6	M14	High
	/RSTI	N7	—	High
Status	/FAULT	N13	N13	—

**Table 12. MachXO Pin Connections GS2974 Cable Equalizer Devices**

Signal Type	Driver Pin Name	U25 (for Rx #0)	U21 (for Rx #1)	Pull-low/high
Control	BYPASS	P3	P8	Low
	MUTE	P4	N8	Low
	MCLADJ	Controlled by potentiometer VR3	Controlled by potentiometer VR2	—
Status	/CD	N3	P9	—

**Table 13. MachXO Pin Connections to LatticeECP3**

Net Name	MachXO Pin	LatticeECP3 Pin
ECP3_XO_SIG0	B10	AM31
ECP3_XO_SIG1	A9	AL31
ECP3_XO_SIG2	A7	AN31
ECP3_XO_SIG3	A6	AP31
ECP3_XO_SIG4	A5	AM32
ECP3_XO_SIG5	B4	AN32
ECP3_XO_SIG6	A3	AB33
ECP3_XO_SIG7	B3	AB34
ECP3_XO_SIG8	A2	Y31
ECP3_XO_SIG9	C3	Y32
ECP3_XO_SIG10	A1	Y33
ECP3_XO_SIG11	B2	Y34

The status pins of these devices can also be observed from LED indicators. Table 13 shows the these LEDs with the associated signals.

**Table 14. LED Indicators for Video Clocking and Cable Equalizer Status**

LED #	Color	Function	Description
D4	Red	Rx GS4911 REF LOST	LED illuminates to indicate that no reference signal is applied or the FSYNC, VSYNC, HSYNC, HSYNC input reference signals do not meet the min/max timing requirement.
D1		Tx GS4911 REF LOST	
D3		Rx GS4911 LOCK LOST	LED illuminates to indicate the GS4911 clock output is not genlocked to the input reference signals.
D2	Green	Tx GS4911 LOCK LOST	
D5		Rx GS4915 LOCK	LED illuminates to indicate that the GS4915 output clock is locked to the input clock selected by IPSEL.
D6		Tx GS4915 LOCK	
D9	Orange	SDI Rx #0 Carrier Detect	LED illuminates to indicate that the equalizer has detected the presence of a good input video signal.
D8		SDI Rx #1 Carrier Detect	

## SERDES

There are three SERDES quads available for the LatticeECP3-95. Each quad include four SERDES channels. These 12 SERDES channels are used for implementing high-speed serial link interfaces. Figure 4 shows the how these channels are used.

Figure 4. Block Diagram of SERDES Usage

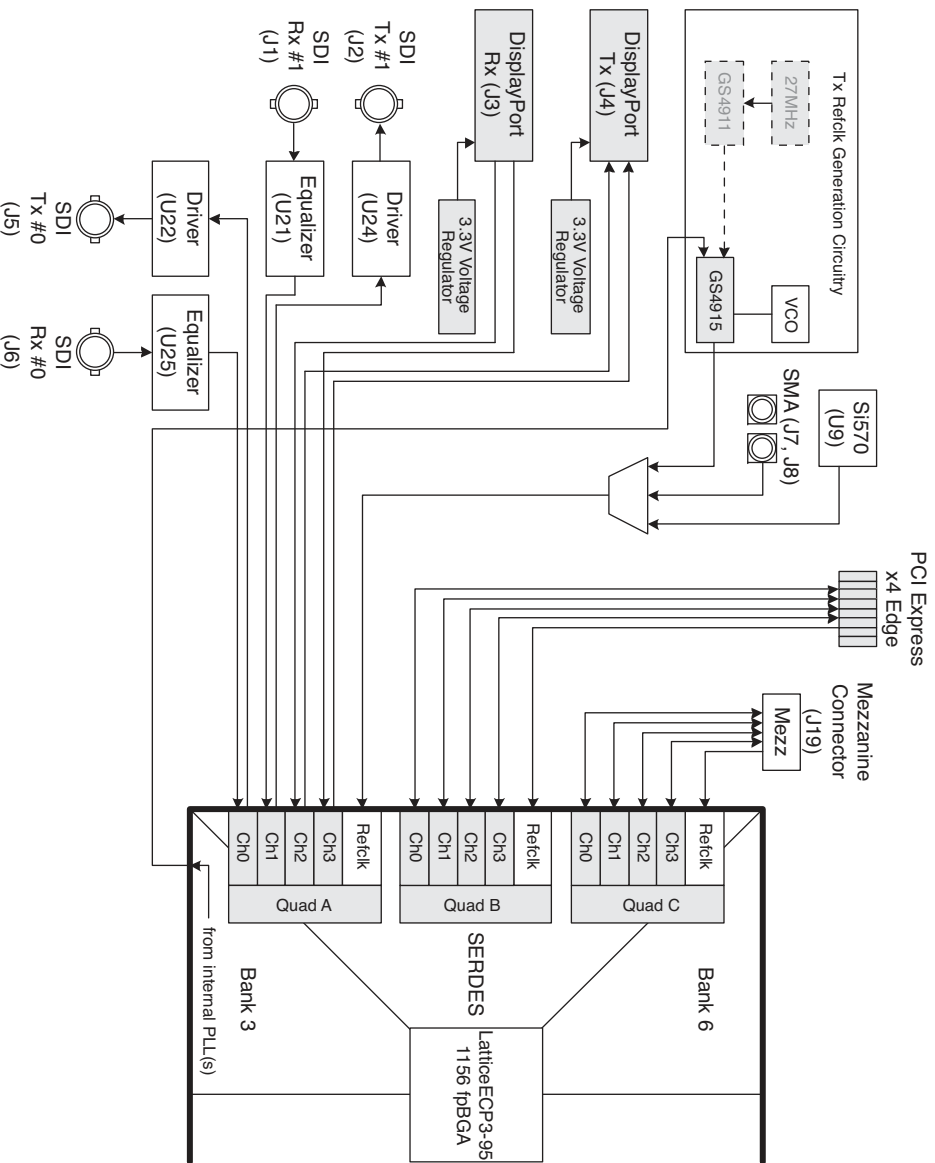

The power supply of the input and output buffers of the SERDES quads can be individually set to either 1.2V or 1.5V. This is done by headers J18, J20~J24. Table 15 shows the jumper settings of these headers for applying either 1.2V or 1.5V power to the SERDES input and output buffers.

Table 15. Jumper Settings for SERDES I/O Buffer (J18, J20~J24)

Header	Buffer	Jumper Setting	Function
J24	Quad A Input (SDI/DP)	1-2	Set PCSA_VCCIB (J24 pin 2) to 1.2V
		2-3	Set PCSA_VCCIB (J24 pin 2) to 1.5V
J20	Quad A Output (SDI/DP)	1-2	Set PCSA_VCCOB (J20 pin 2) to 1.2V
		2-3	Set PCSA_VCCOB (J20 pin 2) to 1.5V
J23	Quad B Input (PCI Express)	1-2	Set PCSB_VCCIB (J23 pin 2) to 1.2V
		2-3	Set PCSB_VCCIB (J23 pin 2) to 1.5V
J21	Quad B Output (PCI Express)	1-2	Set PCSB_VCCOB (J21 pin 2) to 1.2V
		2-3	Set PCSB_VCCOB (J21 pin 2) to 1.5V
J22	Quad C Input (Mezzanine)	1-2	Set PCSC_VCCIB (J22 pin 2) to 1.2V
		2-3	Set PCSC_VCCIB (J22 pin 2) to 1.5V
J18	Quad C Output (Mezzanine)	1-2	Set PCSC_VCCOB (J18 pin 2) to 1.2V
		2-3	Set PCSC_VCCOB (J18 pin 2) to 1.5V

### Quad A (3G-SDI and DisplayPort Video Interfaces)

Quad 0 is used for SDI and DisplayPort video protocols. Channel 0 and 1 of quad 0 are used for SD/HD/3G-SDI. The SD/HD/3G-SDI video signal is a signal-ended video signal transmitting through 75-ohm coaxial cable connecting through BNC connectors. Two cable drivers and two cable equalizers are placed on board for using longer coaxial cable. Channels 2 and 3 are used for support Displayport up to two data lanes.

Table 16 shows the ECP3 connections for the SD/HD/3G-SDI video interface connectors.

**Table 16. SD/HD/3G-SDI Connections (J1, J2, J5 and J6)**

Connector	Description	Cable Driver/Equalizer	SERDES Pin Names	LatticeECP3 Pin #
J5	SDI Tx #0	Driver (U22)	PCSA_HDOU_TP:NJ0	AP21, AN21
J6	SDI Rx #0	Equalizer (U25)	PCSA_HDIN_P:NJ0	AL21, AK21
J2	SDI Tx #1	Driver (U24)	PCSA_HDOU_TP:NJ1	AP20, AN20
J1	SDI Rx #1	Equalizer (U21)	PCSA_HDIN_P:NJ1	AL20, AK20

There are two instances of Gennum clocking circuitry on this board, one for Rx side and the other for Tx side. Since the specification of the high-speed video output stream jitter is critical, it is important to have a clean reference clock for the Tx side serializer. The reference clock of the SERDES channel can come from different a path, but the clock coming in through the dedicated reference clock pins will have the lowest jitter.

The dedicated reference clock pins of quad 0 can be sourcing from the following clocks:

- Clock generated by the on-board Gennum clocking chipsets
- Clock generated by the Silicon Labs Si570
- External differential clock coming through the two SMA connectors

Other than generating from the Gennum chipsets, the transmit reference clock can also receive input clock from an external clock source via a pair of SMA connectors, or from the on-board Silicon Labs Si570. To avoid PCB trace stub and minimize the jitter of the Tx reference clock, two zero-ohm resistors are used for selecting the clock from one of the three clock sources. Figure 5 shows how these two zero-ohm resistors are installed to select a difference clock source. See the schematic in Appendix A (Figure 16) for the detailed clock multiplexing circuitry.

**Figure 5. Resistors for Quad 0 Reference Clock Selection**

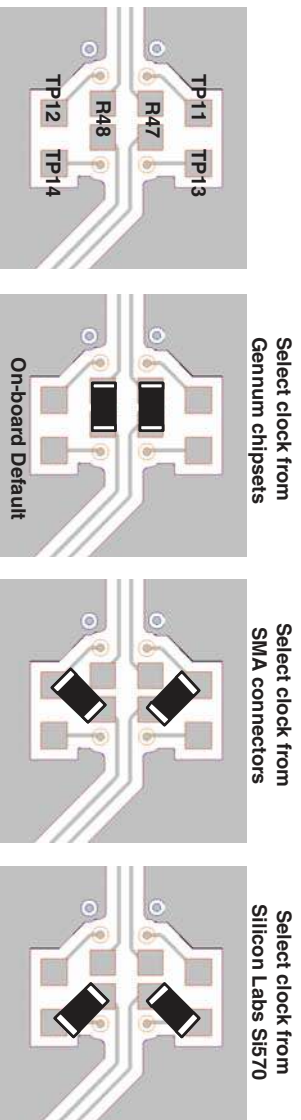

Figure 6 shows the block diagram of the DisplayPort circuitry on this board. Since only two channels in SERDES Quad 0 are used, the DisplayPort video interface on this board can only support up to two lanes. Two instances of 3.3V voltage regulators are used for providing power to the off-board DisplayPort devices when necessary.

Figure 6. Block Diagram of the DisplayPort Video Interface

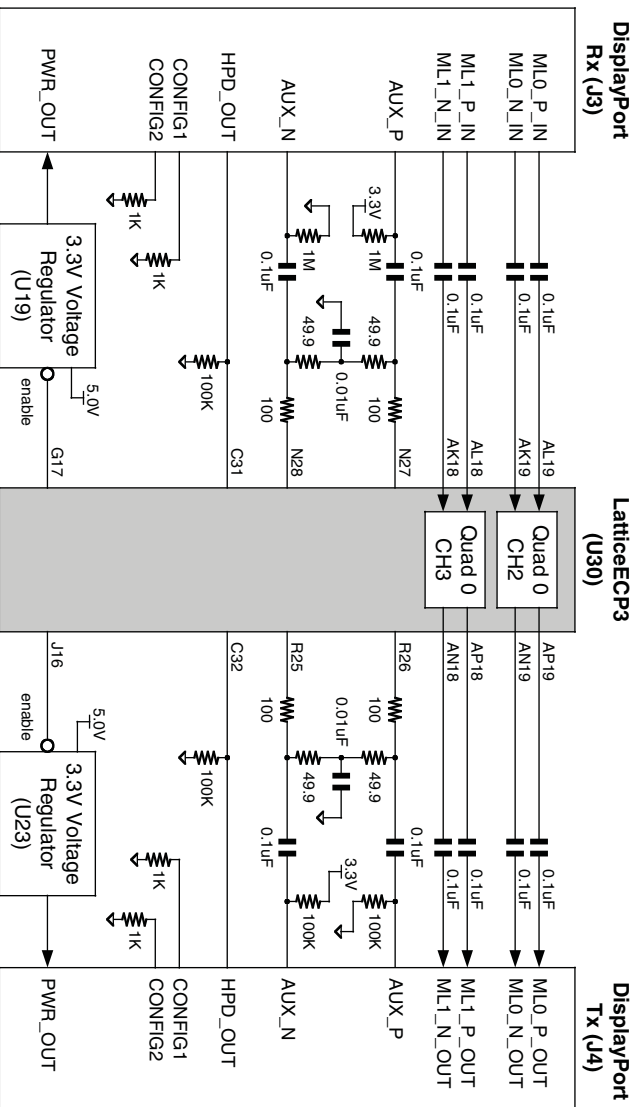

Table 17 shows the pin connections of the DisplayPort video interface.

Table 17. DisplayPort Connections (J3 and J4)

Connector	Pin Name	Pin #	LatticeECP3 Pin Name	LatticeECP3 Pin #
DisplayPort Tx (J4)	MLO_[P:N]_OUT	1 and 2	PCSA_HDOU[TP:N]2	AP19, AN19
	ML1_[P:N]_OUT	4 and 6	PCSA_HDOU[TP:N]3	AL18, AK18
	AUX_[P:N]	15 and 17	PR31[A:B]	R26, R25
	HPD_IN	18	PT143B	C32
DisplayPort Rx (J3)	MLO_[P:N]_IN	10 and 12	PCSA_HDIN[IP:N]2	AL19, AK19
	ML1_[P:N]_IN	7 and 8	PCSA_HDIN[IP:N]3	AL18, AK18
	AUX_[P:N]	15 and 17	PR22[A:B]	N27, N28
	HPD_OUT	18	PT145B	C31

### Quad B (PCI Express x4)

This board is equipped to communicate directly as an add-on card to a PCI Express host. It is designed with edge-fingers (CN1) to fit directly into a x1 host receptacle. Power can be supplied directly from the PCI Express host via the edge-finger connections.

All channels of Quad 1 are connected to the PCI Express Edge connector (CN1) for implementing a PCI Express x4 interface. The dedicated reference clock input pins and a reset control signal are also connected to the PCI Express edge connector.

Table 18. SERDES PCI Express Interconnections

PCI Express Name	PCI Express Pin #	LatticeECP3 Pin Name	LatticeECP3 Pin #	AC Coupling	PCI Express Pin Description
PERP0	A16	PCSB_HDOU[TP]0	AP17	C365	Receiver differential pair, Lane 0
PERn0	A17	PCSB_HDOU[TN]0	AN17	C366	

**Table 18. SERDES PCI Express Interconnections (Continued)**

PCI Express Name	PCI Express Pin #	LatticeECP3 Pin Name	LatticeECP3 Pin #	AC Coupling	PCI Express Pin Description
PERp1	A21	PCSB_HDOU1P1	AP16	C372	Receiver differential pair, Lane 1
PERn1	A22	PCSB_HDOU1N1	AN16	C375	
PERp2	A25	PCSB_HDOU2P2	AP15	C376	Receiver differential pair, Lane 2
PERn2	A26	PCSB_HDOU2N2	AN15	C379	
PERp3	A29	PCSB_HDOU3P3	AP14	C382	Receiver differential pair, Lane 3
PERn3	A30	PCSB_HDOU3N3	AN14	C383	
PETp0	B14	PCSB_HDINP0	AL17	None	
PETn0	B15	PCSB_HDINN0	AK17	None	
PETp1	B19	PCSB_HDINP1	AL16	None	Transmitter differential pair, Lane 1
PETn1	B20	PCSB_HDINN1	AK16	None	
PETp2	B23	PCSB_HDINP2	AL15	None	Transmitter differential pair, Lane 2
PETn2	B24	PCSB_HDINN2	AK15	None	
PETp3	B27	PCSB_HDINP3	AL14	None	Transmitter differential pair, Lane 3
PETn3	B28	PCSB_HDINN3	AK14	None	
REFCLK+	A13	PCSB_REFCLKP	AH15	None	
REFCLK-	A14	PCSB_REFCLKN	AH16	None	Reference clock (differential pair)
PERST#	A11	PT109A	J21	None	Fundamental reset

### Quad C (Daughter Board Expansion)

All channels of Quad 2 are connected to a high-speed Molex Mezzanine connector for working with a 3.2 x 2.5" daughter board. Users can design a daughter board for implementing anything that requires the SERDES quad, such as the high-speed HDMI/DVI video interface.

**Figure 7. Daughter Board Connection**

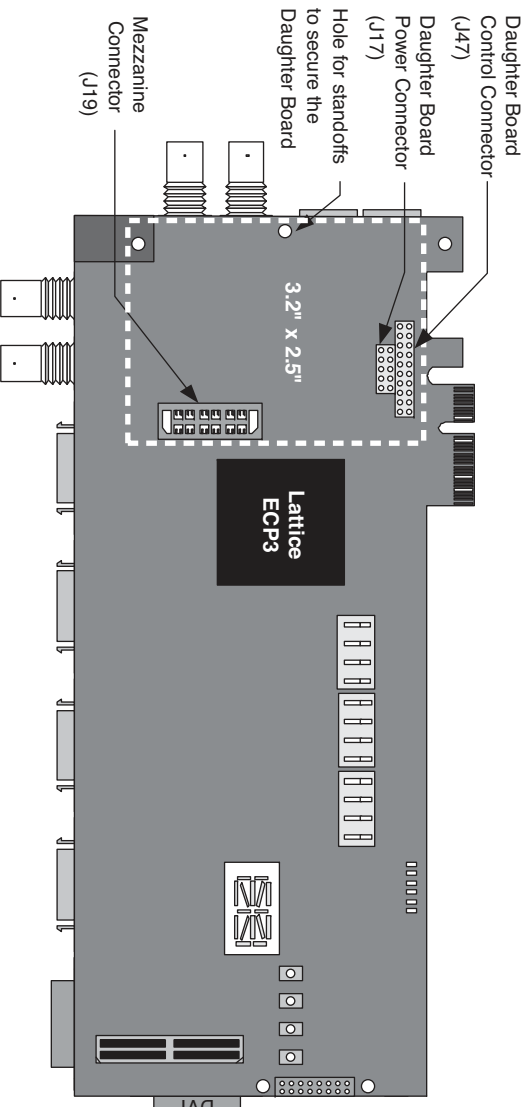

Other than the four input/output Quad 2 SERDES channels and the differential reference clock pair, there are three differential pairs of general purpose I/Os connected between the Mezzanine connector and the LatticeECP3 device. These signals can be used for the control or status signals of the daughter board. A 4-pin power connector is used to provide power to the daughter board; Tables 19 and 20 show the pin connections of the Mezzanine and the power connectors. Table 21 shows the pin connections between the LatticeECP3 and the daughter board con-

trol connector.

**Table 19. Mezzanine Connections (J19)**

J19 Pin #	LatticeECP3 Pin Name	LatticeECP3 Pin #	Description
1	PCSC_HDINP3	AL22	SERDES Quad 2 Channel 3 Input
2	PCSC_HDINN3	AK22	SERDES Quad 2 Channel 3 Input
3	PCSC_HDINP2	AL23	SERDES Quad 2 Channel 2 Input
4	PCSC_HDINN2	AK23	SERDES Quad 2 Channel 2 Input
5	PCSC_HDINP1	AL24	SERDES Quad 2 Channel 1 Input
6	PCSC_HDINN1	AK24	SERDES Quad 2 Channel 1 Input
7	PCSC_HDINP0	AL25	SERDES Quad 2 Channel 0 Input
8	PCSC_HDINN0	AK25	SERDES Quad 2 Channel 0 Input
9	PR25A	P28	User-defined Differential Signal Pair 1
10	PR25B	P27	User-defined Differential Signal Pair 1
11	PR28A	R28	User-defined Differential Signal Pair 2
12	PR28B	R27	User-defined Differential Signal Pair 2
13	PCSC_HDOU TP3	AL22	SERDES Quad 2 Channel 3 Output
14	PCSC_HDOU TN3	AK22	SERDES Quad 2 Channel 3 Output
15	PCSC_HDOU TP2	AL23	SERDES Quad 2 Channel 2 Output
16	PCSC_HDOU TN2	AK23	SERDES Quad 2 Channel 2 Output
17	PCSC_HDOU TP1	AL24	SERDES Quad 2 Channel 1 Output
18	PCSC_HDOU TN1	AK24	SERDES Quad 2 Channel 1 Output
19	PCSC_HDOU TP0	AL25	SERDES Quad 2 Channel 0 Output
20	PCSC_HDOU TN0	AK25	SERDES Quad 2 Channel 0 Output
21	PCSC_REFCLKP	AH22	SERDES Quad 2 Reference Clock
22	PCSC_REFCLKN	AH23	SERDES Quad 2 Reference Clock
23	PR19A	N26	User-defined Differential Signal Pair 0
24	PR19B	P26	User-defined Differential Signal Pair 0

**Table 20. Daughter Board Power Connections (J17)**

J17 Pin Number	Voltage	Maximum Current
2, 4	5.0V	~8A
6, 8	3.3V	~8A
10	1.8V	~2A
1, 3, 5, 7, 9	GND	

**Table 21. Daughter Board Control Signals Connections (J47)**

J47 Pin Number	LatticeECP3 Pin Number	Signal Name	J47 Pin Number	LatticeECP3 Pin Number	Signal Name
1	AM8	MZ_CTRL0	2	AM7	MZ_CTRL1
3	AK8	MZ_CTRL2	4	AK7	MZ_CTRL3
5	AG9	MZ_CTRL4	6	AF9	MZ_CTRL5
7	AK6	MZ_CTRL6	8	AE9	MZ_CTRL7
9	AH7	MZ_CTRL8	10	AL3	MZ_CTRL9
11	AJ3	MZ_CTRL10	12	AJ2	MZ_CTRL11
13	AN8	MZ_CTRL12	14	AN7	MZ_CTRL13
15	AH9	MZ_CTRL14	16	AE3	MZ_CTRL15
17	AE4	MZ_CTRL16	18	AD3	MZ_CTRL17
19	AD4	MZ_CTRL18	20	AA8	MZ_CTRL19

Figure 8 shows the mechanical dimensions required for designing a daughter board.

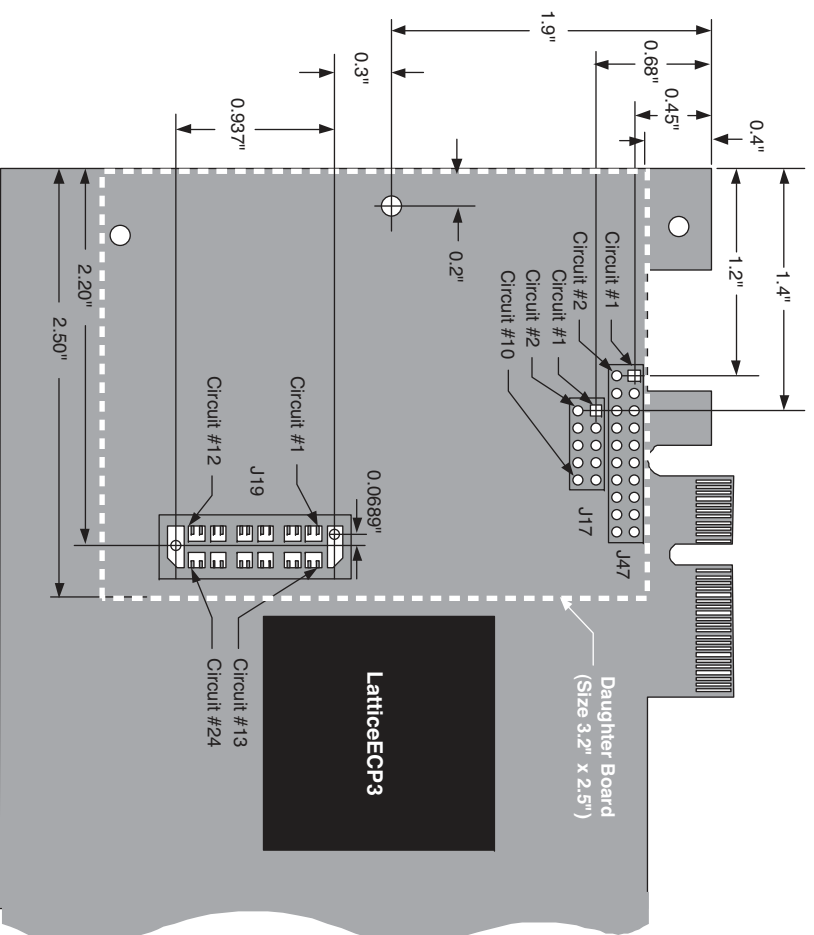
**Figure 8. Mechanical Drawing of the Daughter Board Connection**

## ChannelLink and CameraLink Video Interfaces

There are two LVDS video interfaces on the board, ChannelLink and CameraLink. Both interfaces include a receive channel, but only the ChannelLink interface includes a transmit channel. All of these channels use the same on-board 3M MDR-26 (p/n 10226-1210VE) connectors. However, since the pinouts of these two interfaces are different, different 3M Mini D Ribbon (MDR) cables must be used. The cables are listed below. They look the same but have different pinouts.



- 3M ChannelLink Cable: 14526-EZ8B-XXX-07C
- 3M Cameralink Cable: 14X26-SZLB-XXX-0LC

Other than the ChannelLink and Cameralink LVDS signals, some of the LVDS signals are also connected to the two RJ45 connectors on J44 and J45. Tables 22 to 25 show the connections of these LVDS connectors.

**Table 22. ChannelLink Tx Connections (J9)**

Signal Name	J9 Pin #	LatticeECP3 Pin #	LatticeECP3 Pin Type	External Resistor
TX OUT0+	15	AM29	True LVDS Output	None
TX OUT0-	14	AN29	True LVDS Output	None
TX OUT1+	5	AL30	True LVDS Output	None
TX OUT1-	4	AM30	True LVDS Output	None
TX OUT2+	7	AJ31	True LVDS Output	None
TX OUT2-	6	AK31	True LVDS Output	None
TX OUT3+	13	AA28	True LVDS Output	None
TX OUT3-	12	AA27	True LVDS Output	None
TX CLKOUT+	23	AH33	True LVDS Output	None
TX CLKOUT-	22	AJ33	True LVDS Output	None

**Table 23. ChannelLink Rx Connections (J10)**

Signal Names	J10 Pin #	LatticeECP3 Pin#	LatticeECP3 Pin Type	External Resistor
RX IN0+	12	V31	LVDS Input	R65 (100 Ω)
RX IN0-	13	V30	LVDS Input	
RX IN1+	22	W34	LVDS Input	R63 (100 Ω)
RX IN1-	23	W33	LVDS Input	
RX IN2+	20	W32	LVDS Input	R60 (100 Ω)
RX IN2-	21	W31	LVDS Input	
RX IN3+	14	W29	LVDS Input	R58 (100 Ω)
RX IN3-	15	W28	LVDS Input	
RX CLKIN+	4	U28	LVDS Input	
RX CLKIN-	5	V28	LVDS Input	R61 (100 Ω)

**Table 24. RJ45 Connections (J44 and J45)**

Signal Name	Pin#	LatticeECP3 Pin#	LatticeECP3 Pin Type	External Resistor
RJ45_OUT_P0	1 (J44)	W27	True LVDS Output	None
RJ45_OUT_N0	2 (J44)	W26	True LVDS Output	None
RJ45_OUT_P1	3 (J44)	AA25	True LVDS Output	None
RJ45_OUT_N1	6 (J44)	AA26	True LVDS Output	None
RJ45_OUT_P2	4 (J44)	W30	Emulated LVDS Output	None
RJ45_OUT_N2	5 (J44)	W29	Emulated LVDS Output	None
RJ45_OUT_P3	7 (J44)	Y26	True LVDS Output	None
RJ45_OUT_N3	8 (J44)	Y25	True LVDS Output	None
RJ45_IN_P0	1 (J45)	AM34	LVDS Input	R65 (100 Ω)
RJ45_IN_N0	2 (J45)	AM33	LVDS Input	
RJ45_IN_P1	3 (J45)	AC32	LVDS Input	
RJ45_IN_N1	6 (J45)	AC31	LVDS Input	R63 (100 Ω)

**Table 24. RJ45 Connections (J44 and J45) (Continued)**

Signal Name	Pin#	LatticeECP3 Pin#	LatticeECP3 Pin Type	External Resistor
RJ45_IN_P2	4 (J45)	AA34	LVDS Input	R60 (100 Ω)
RJ45_IN_N2	5 (J45)	AA33	LVDS Input	
RJ45_IN_P3	7 (J45)	P30	LVDS Input	R58 (100 Ω)
RJ45_IN_N3	8 (J45)	R29	LVDS Input	

**Table 25. CameraLink Rx Connections (J12)**

Signal Name	J12 Pin #	LatticeECP3 Pin#	LatticeECP3 Pin Type	External Resistor
X0+	12	U32	LVDS Input	R80 (100 Ω)
X0-	25	U31	LVDS Input	
X1+	11	U34	LVDS Input	R76 (100 Ω)
X1-	24	U33	LVDS Input	
X2+	10	T34	LVDS Input	R71 (100 Ω)
X2-	23	T33	LVDS Input	
X3+	8	T32	LVDS Input	R68 (100 Ω)
X3-	21	T31	LVDS Input	
XCLK+	9	U26	LVDS Input	R70 (100 Ω)
XCLK-	22	U27	LVDS Input	
SerTC+	20	N30	Emulated LVDS Output	RN33A
SerTC-	7	N29	Emulated LVDS Output	
SerTFG+	6	P32	LVDS Input	R206 (100 Ω)
SerTFG-	19	P31	LVDS Input	
CC1+	5	R34	Emulated LVDS Output	RN32A
CC1-	18	R33	Emulated LVDS Output	
CC2+	17	R31	Emulated LVDS Output	RN32B
CC2-	4	R30	Emulated LVDS Output	
CC3+	3	P34	Emulated LVDS Output	RN31A
CC3-	16	P33	Emulated LVDS Output	
CC4+	15	N34	Emulated LVDS Output	RN31B
CC4-	2	N33	Emulated LVDS Output	

## DVI Video Interface

There are two DVI video connectors on this board, one for DVI receive and the other for DVI transmit. The I/Os on the banks 0 and 1 of LatticeECP3 support the TRLVDS (Transition Reduced LVDS) I/O standard and can be used to receive video signals with TMDS standard such as DVI and HDMI. These I/Os can support a maximum band-

width of up to 1Gbps. The TMDS signals of DVI Rx connector (J16). For DVI Tx, the TMDS transmitter TFP410 from TI is used to convert and encode the parallel R, G, B pixel data to TMDS signals. These TMDS signals are then connected to J14.

Tables 26 and 27 show the LatticeECP3 pin connections to these two DVI connectors.

**Table 26. DVI Rx Connections (J16)**

J16 Pin #	Pin Name	LatticeECP3 Pin #	Description
18	TMDS_Data0+	C16	TMDS Blue Data Channel
17	TMDS_Data0-	D16	
10	TMDS_Data1+	A16	TMDS Green Data Channel
9	TMDS_Data1-	B16	
2	TMDS_Data2+	C17	TMDS Red Data Channel
1	TMDS_Data2-	D17	
23	TMDS_Clock0+	J17	TMDS Clock Channel
24	TMDS_Clock0-	H17	
6	DDC_Clock	D14	DVI Rx DDC Clock
7	DDC_Data	J15	DVI Rx DDC Data
16	Hot Plug Detect	F13	DVI Rx Hot Plug Detect

**Table 27. DVI Tx Connections (J14)**

J14 Pin #	J14 Pin Name	TFP410 Pin	TFP410 Pin #	LatticeECP3 Pin #	Description
		DATA7	54	A4 (MSB)	TMDS Blue Data Channel
		DATA6	55	A5	
		DATA5	58	G12	
		DATA4	59	G13	
		DATA3	60	A12	
		DATA2	61	B12	
		DATA1	62	J14	TMDS Green Data Channel
		DATA0	63	H13 (LSB)	
		DATA15	44	B3 (MSB)	
		DATA14	45	A2	
		DATA13	46	D5	
		DATA12	47	C6	
10 and 9	TMDS_Data1+TMDS_Data1-	DATA11	50	B4	TMDS Green Data Channel
		DATA10	51	A3	
		DATA9	52	D6	
		DATA8	53	C5 (LSB)	
		DATA23	36	C3 (MSB)	
		DATA22	37	C4	
2 and 1	TMDS_Data2+TMDS_Data2-	DATA21	38	D3	TMDS Red Data Channel
		DATA20	39	C2	
		DATA19	40	B1	
		DATA18	41	B2	
		DATA17	42	E4	
		DATA16	43	D4 (LSB)	
6	DDC_Clock	—	—	C14	DVI Tx DDC Clock

**Table 27. DVI Tx Connections (J14) (Continued)**

J14 Pin #	J14 Pin Name	TFP410 Pin	TFP410 Pin #	LatticeECP3 Pin #	Description
7	DDC_Data	—	—	G15	DVI Tx DDC Data
—	—	IDCKP	57	K14	—
—	—	DE	2	D13	—
—	—	VSYNC	5	J13	—
—	—	HSYNC	4	H14	—
—	—	ISEL/RSTN	13	G21	—
—	—	BSEL/SCL	15	B13	—
—	—	DSEL/SDA	14	A13	—

## RS-232 Interface

A 2x5 header (J38) provides a RS-232 port connection to the LatticeECP3 device via a RS-232 transceiver MAX232. Either the DB25 or DB9 cable can be connected to this header for providing a RS-232 port with industrial standard pinout. Table 28 shows the pin connections of this header.

**Table 28. RS-232 Interface Header Pin Connections (J38)**

J38 Pin #	Pin Name	Net Name	LatticeECP3 Pin #	J38 Pin #	Pin Name	Net Name	LatticeECP3 Pin #
1	N.C.	—	—	2	N.C.	—	—
3	TXD	RS232_TXD	F12 (Input)	4	N.C.	—	—
5	RXD	RS232_RXD	E11 (Output)	6	N.C.	—	—
7	N.C.	—	—	8	N.C.	—	—
9	N.C.	GND	—	10	N.C.	—	—

## LCD Interface

A 2x9 header (J43) provides a connection to LCD modules such as the 20-character x 2 line LCD module LCM-S02002DSR or LCM-S02002DSR (with backlight LED) from Lumex. The board includes two variable resistors for LCD adjustments. VR6 adjusts the backlight and VR5 provides contrast adjustment. A user design must be included in the FPGA to drive this feature. This header can also be used for probe points for observing FPGA pins. Pin 1 and Pin 2 of header J43 are dummy pins that connect to nothing. When installing the Lumex LCD module, these two pins should be skipped. Table 29 shows the pin connections of this header.

**Table 29. LCD Interface Header Pin Connections (J43)**

J43 Pin#	LatticeECP3 Pin #	LCM-S02002 Pin #	Net Names	J43 Pin#	LatticeECP3 Pin #	LCM-S02002 Pin#	Net Names
1	—	—	N.C. (Dummy)	2	—	—	N.C. (Dummy)
3	—	1	GND	4	—	2	5V
5	—	3	VO (Contrast)	6	H15	4	LCD5 / LCD_RS
7	A8	5	LCD0 / LCD_R/W	8	E17	6	LCD6 / LCD_E
9	A9	7	LCD1 / LCD_DB0	10	B14	8	LCD7 / LCD_DB1
11	A7	9	LCD2 / LCD_DB2	12	A14	10	LCD8 / LCD_DB3
13	E15	11	LCD3 / LCD_DB4	14	E13	12	LCD9 / LCD_DB5
15	D15	13	LCD4 / LCD_DB6	16	E12	14	LCD10 / LCD_DB7
17	—	15	ANODE (Backlight)	18	—	16	GND

## Switches and LEDs

There are many on-board DIP switches, push-button switches, discrete LEDs and a 16-segment LED display that can be used to provide static inputs and outputs for a design. Figure 9 shows the locations of these components.

**Figure 9. Switch and LED Locations**

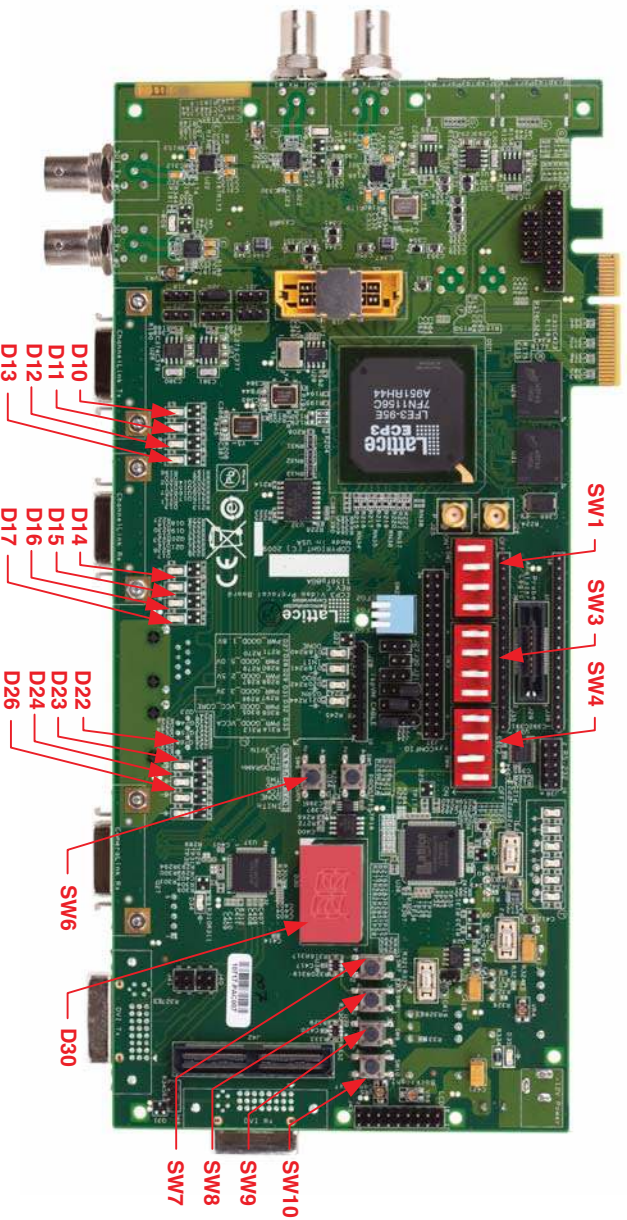

## DIP Switches (SW1, SW3 and SW4)

There are three SPDT toggle-DIP switches on this board. Each of these switches includes four positions to make a total number of 12 static input signals to a design. Table 30 shows the pin connections and colors of these LEDs.

**Table 30. DIP Switch Connections**

Switch #	Position #	Signal	LatticeECP3 Pin #	LatticeECP3 I/O Bank (Voltage)
SW1	1	SWITCH1	Y5	Bank 6 (1.8V)
	2	SWITCH2	Y4	
	3	SWITCH3	Y9	
	4	SWITCH4	Y10	
SW3	1	SWITCH5	AD2	
	2	SWITCH6	AD1	
	3	SWITCH7	AC6	
	4	SWITCH8	AC7	
SW4	1	SWITCH9	AM1	
	2	SWITCH10	AM2	
	3	SWITCH11	AE1	
	4	SWITCH12	AE2	

### Push-button Switches (SW6, SW7, SW8, SW9 and SW10)

Five push-buttons can also be used to provide inputs that require pulses. There are de-bouncers between the push-buttons and the LatticeECP3 to remove the glitches of the push-button signals. When pressing these push-buttons, logic 0 will be sent to the connected LatticeECP3 pins. Table 31 shows the corresponding pin connections between the push-buttons and the LatticeECP3 pins.

**Table 31. Push-button Switch Connections**

Signal	Switch #	LatticeECP3 Pin #	LatticeECP3 I/O Bank (Voltage)
GSRN	SW6	J20	Bank 1 (2.5V)
PB4	SW7	U4	
PB3	SW8	U5	Bank 7 (1.8V)
PB2	SW9	P1	
PB1	SW10	P2	

### Discrete LEDs (D10~D17, D22~D24, and D26)

There are 12 discrete LEDs for use as status indicators. These 12 LEDs are divided into three groups, (D10, D11, D12, D13), (D14, D15, D16, D17) and (D22, D23, D24, D26). Each group has four LEDs and each LED is in a different color. Table 32 shows the pin connections and colors of these LEDs.

**Table 32. Discrete LED Connections**

Signal	LED #	LatticeECP3 Pin #	ECP3 I/O Bank (Voltage)	Color
LED12	D10	AA31	Bank 1 (2.5V)	Blue
LED11	D11	AN34		Green
LED10	D12	AN33	Bank 3 (2.5V)	Orange
LED9	D13	AP33		Red
LED8	D14	AP32		Blue
LED7	D15	AL32		Green
LED6	D16	AK32	Bank 2 (2.5V)	Orange
LED5	D17	N32		Red
LED4	D22	N31	Bank 2 (2.5V)	Blue
LED3	D23	T29		Green
LED2	D24	T28		Orange
LED1	D26	T27		Red

### 16-Segment LED Display (D30)

The LatticeECP3 general-purpose I/O pins are connected to a 16-segment display, as shown in Table 33. These pins can be driven low to illuminate the display segments.

**Table 33. 16-Segment LED Display Connections**

Segment	LatticeECP3 Pin
A	H20
B	A18
C	G18
D	D18
DP	B18
E	L19
F	C19
G	J19
H	K19
K	G19
M	H19
N	K20
P	F19
R	H18
S	J18
T	D19
U	E18

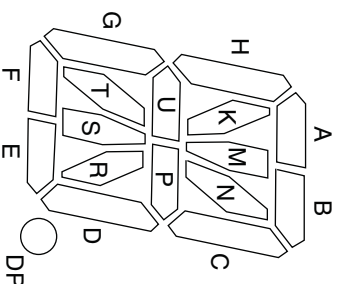

### Logic Analyzer Connector and Test Points

For debugging purposes, all unused LatticeECP3 I/Os are connected to connectors/headers for debugging a design using test equipment such as logic analyzers or scopes.

#### Logic Analyzer Connector

An on-board Micror connector is connected to many LatticeECP3 I/Os to make it easy to use a logic analyzer for debugging the FPGA design. The Micror connector pins are connected to different I/O banks with different Vccio voltages. Users may need to configure the threshold voltage of the logic analyzer pod to match the signals being monitored. Other than connecting to the Micror connector, these LatticeECP3 pins are also connected to two standard 100-mil pitch headers for use with logic analyzers or scopes that do not support Micror connection. Table 34 shows the LatticeECP3 pin connections to the Micror connector and the two headers.

**Table 34. Logic Analyzer Connections (J29, J35 and J36)**

J29 Pin #	Signal	J35 Pin #	J36 Pin #	LatticeECP3 Pin #	LatticeECP3 I/O Bank (Voltage)
1	—	—	—	—	—
2	—	—	—	—	—
3	—	—	—	—	GND
4	—	—	—	—	—
5	LA1	—	1	D33	Bank 8 (3.3V)
6	LA2	1	—	D31	Bank 0 (3.3V)
7	LA3	—	2	K15	
8	LA4	2	—	C13	

**Table 34. Logic Analyzer Connections (J29, J35 and J36) (Continued)**

J29 Pin #	Signal	J35 Pin #	J36 Pin #	LatticeECP3 Pin #	LatticeECP3 I/O Bank (Voltage)
9	LA5	—	3	J22	Bank 1 (2.5V)
10	LA6	3	—	J23	
11	LA7	—	4	F22	
12	LA8	4	—	G23	
13	LA9	—	5	A24	
14	LA10	5	—	B24	
15	LA11	—	6	H22	
16	LA12	6	—	H23	
17	LA13	—	7	K23	
18	LA14	7	—	K24	
19	LA15	—	8	C28	
20	LA16	8	—	D28	
21	LA17	—	9	G26	
22	LA18	9	—	AA2	
23	LA19	—	10	AJ6	
24	LA20	10	—	AL8	
25	LA21	—	11	AM5	
26	LA22	11	—	AM6	Bank 6 (1.8V)
27	LA23	—	12	AN6	
28	LA24	12	—	AL7	
29	LA25	—	13	AM4	
30	LA26	13	—	AP5	
31	LA27	—	14	AP6	
32	LA28	14	—	—	
33	LA29	—	15	—	
34	LA30	15	—	—	
35	LA31	—	16	—	
36	LA32	16	—	—	
37	LA33	—	17	—	
38	LA34	17	—	—	

## Known Issues

### 1. DDR2 Reference Voltage

There are two DDR2 devices on the board – U29 and U31. When the design is using only one DDR2 device, the DDR2\_REF signal for the unused DDR2 device will be pulled up by the unused LatticeECP3 pin. This pulls the Vref voltage away from the 0.9V generated by the LP2997 voltage regulator to around 1.6~1.7V. The DDR2 will not work with the wrong reference voltage; the DDR2 accesses will fail. The DDR2\_REF generated by LP2997 is connected to LatticeECP3 pin-V7(VREF1 of Bank 6 for the DDR2 device on U29) and pin-R9 (VREF1 of Bank 7 for the DDR2 device on U31). To avoid being pulled up to the wrong voltage, the unused VREF1 pin cannot be left unused because all unused pins will be pulled up by default. The easiest workaround is adding dummy logic with one input and one output, and then assigning this input pin to the unused VREF1 pin.



## 2. DDR2 Bandwidth

This board does not include the recommended DDR2 termination resistors. Because of this, DDR2 may not work correctly on this board at all frequencies. Performance on individual boards may vary, but testing shows the best results at 125MHz, 150 MHz and 250MHz. 200MHz operation may be compromised due to this termination issue. It has also been found that U31 tends to have such issue more likely than U29. Based on the above findings, the following is strongly recommended when using the on-board DDR2 memory:

- If only one memory device is needed, U29 is recommended over U31.
- DDR2 memory operating frequency around 200 MHz on this board should be avoided if possible.

If the operating frequency around 200 MHz cannot be avoided, the following may help work around or mitigate the issue:

- Set the DDR2 memory interface related pins on FPGA DRIVE = 8 and SLEWRATE = SLOW in Design Planner.
- Change the on-die-termination (ODT) of the DDR2 memory device. This can be done by setting the desired value for the extended mode register. ODT = 50Ω appears to be better than the others on the board tested, but this may vary from board to board. Users may wish to experiment with different ODT options to determine the best ODT value.

## Ordering Information

Description	Ordering Part Number	China RoHS Environment-Friendly Use Period (EFUP)
LatticeECP3 Video Protocol Board	LFE3-95EA-V-EVN <sup>1</sup>	

1. Some early revision C LatticeECP3 Video Protocol Boards have the LatticeECP3 “E” device installed (LFE3-95E-V-EVN). For these boards, see TN1180, [LatticeECP3 High-Speed I/O Interface](#), for information on the differences between the LatticeECP3 “E” and “EA” devices.

## Technical Support Assistance

Hotline: 1-800-LATTICE (North America)  
 +1-503-268-8001 (Outside North America)

e-mail: [techsupport@latticesemi.com](mailto:techsupport@latticesemi.com)

Internet: [www.latticesemi.com](http://www.latticesemi.com)

## Revision History

Date	Version	Change Summary
March 2010	01.0	Initial release.
March 2011	01.1	Added Known Issues text section.
May 2011	01.2	Updated Ordering Information table for LFE3-95EA-V-EVN part number.
October 2012	01.3	Updated document with new corporate logo. Updated LatticeECP3 pin numbers in the Push-button Switch Connections table. FPGA Configuration schematic – Updated name of PR5A in the ECP3 Configuration I/Os section.

© 2012 Lattice Semiconductor Corp. All Lattice trademarks, registered trademarks, patents, and disclaimers are as listed at [www.latticesemi.com/legal](http://www.latticesemi.com/legal). All other brand or product names are trademarks or registered trademarks of their respective holders. The specifications and information herein are subject to change without notice.

Appendix A. Schematic

Figure 10. Block Diagram

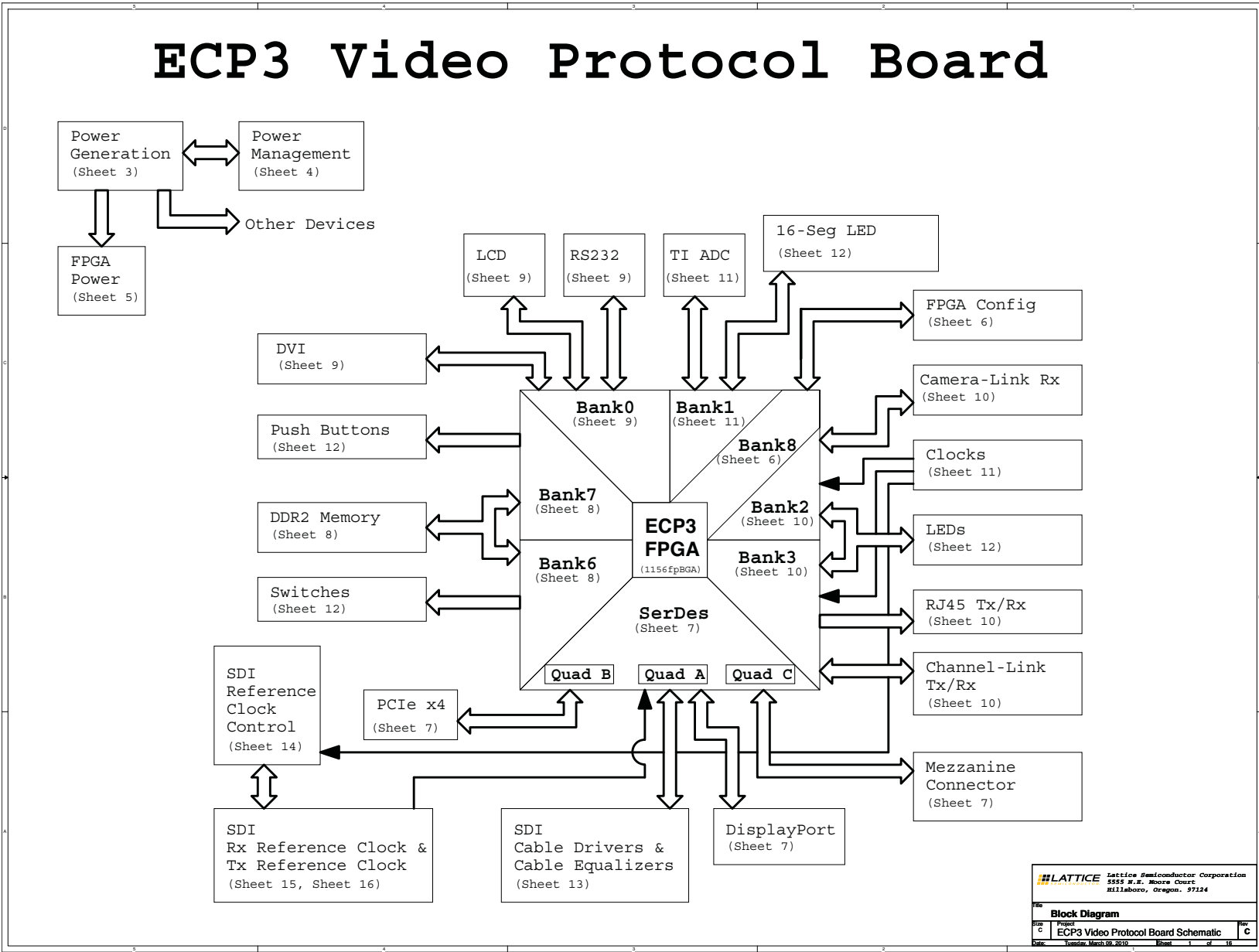

Figure 11. Assembly Drawing

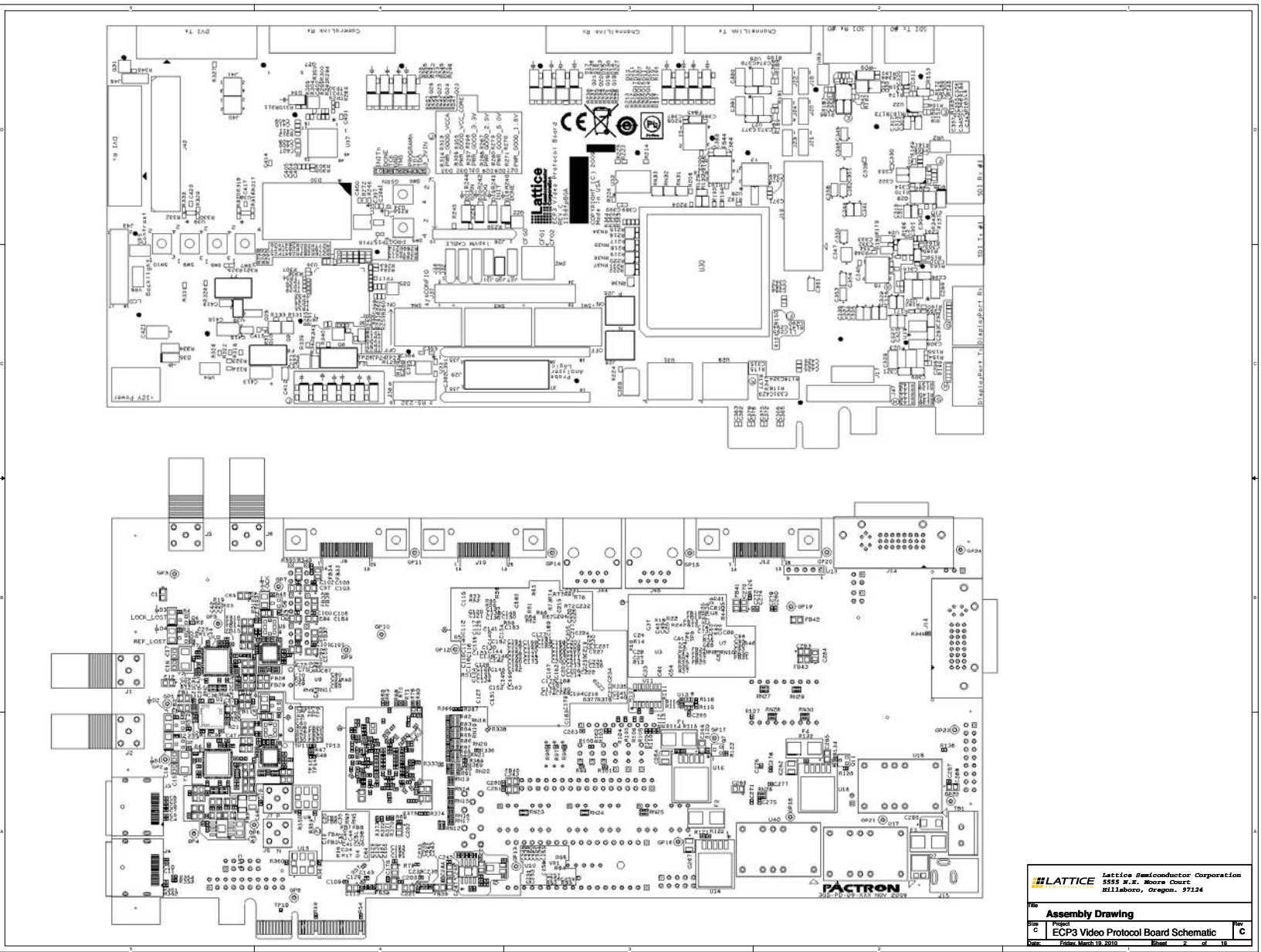



Figure 13. Power Management

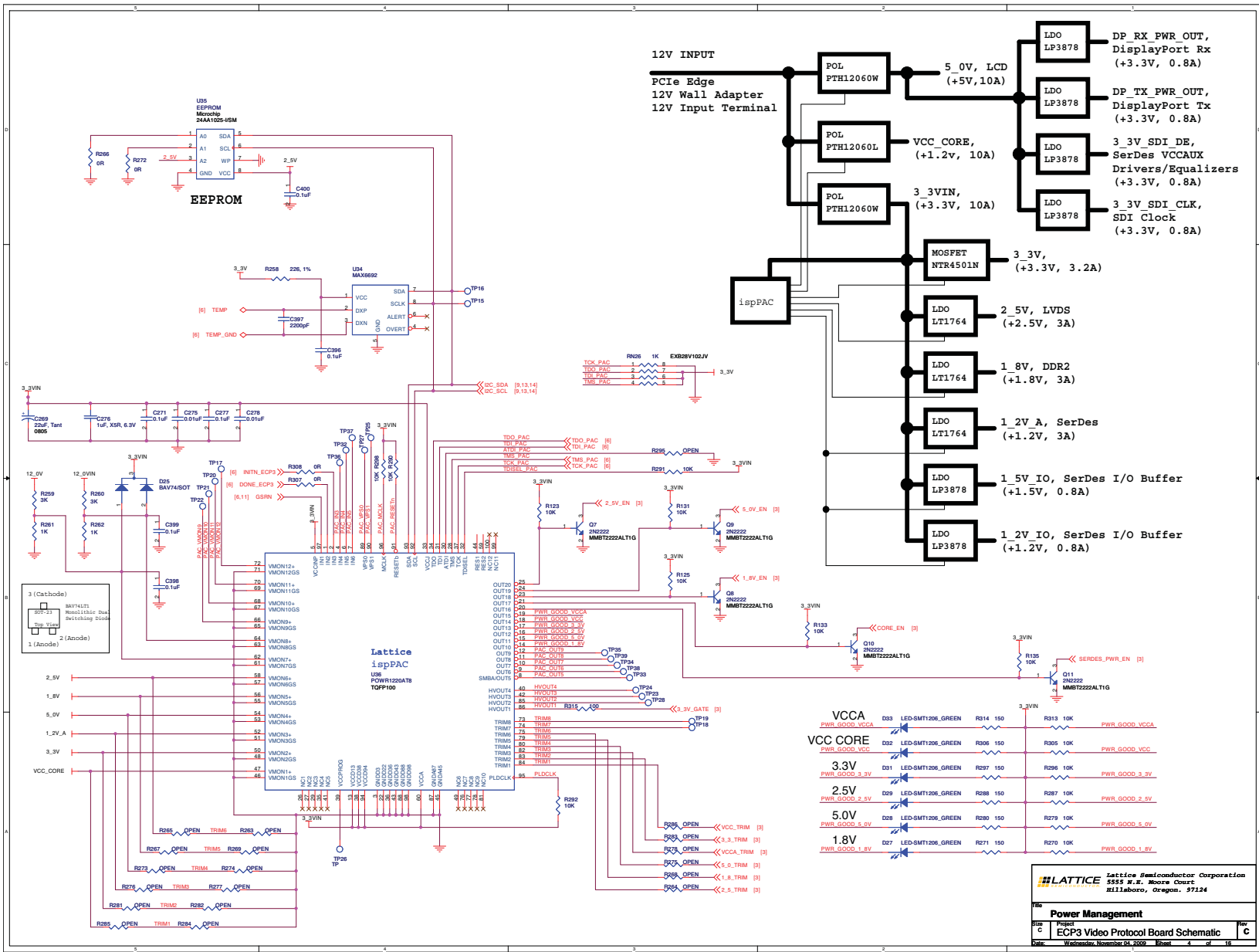



Figure 15. FPGA Configuration

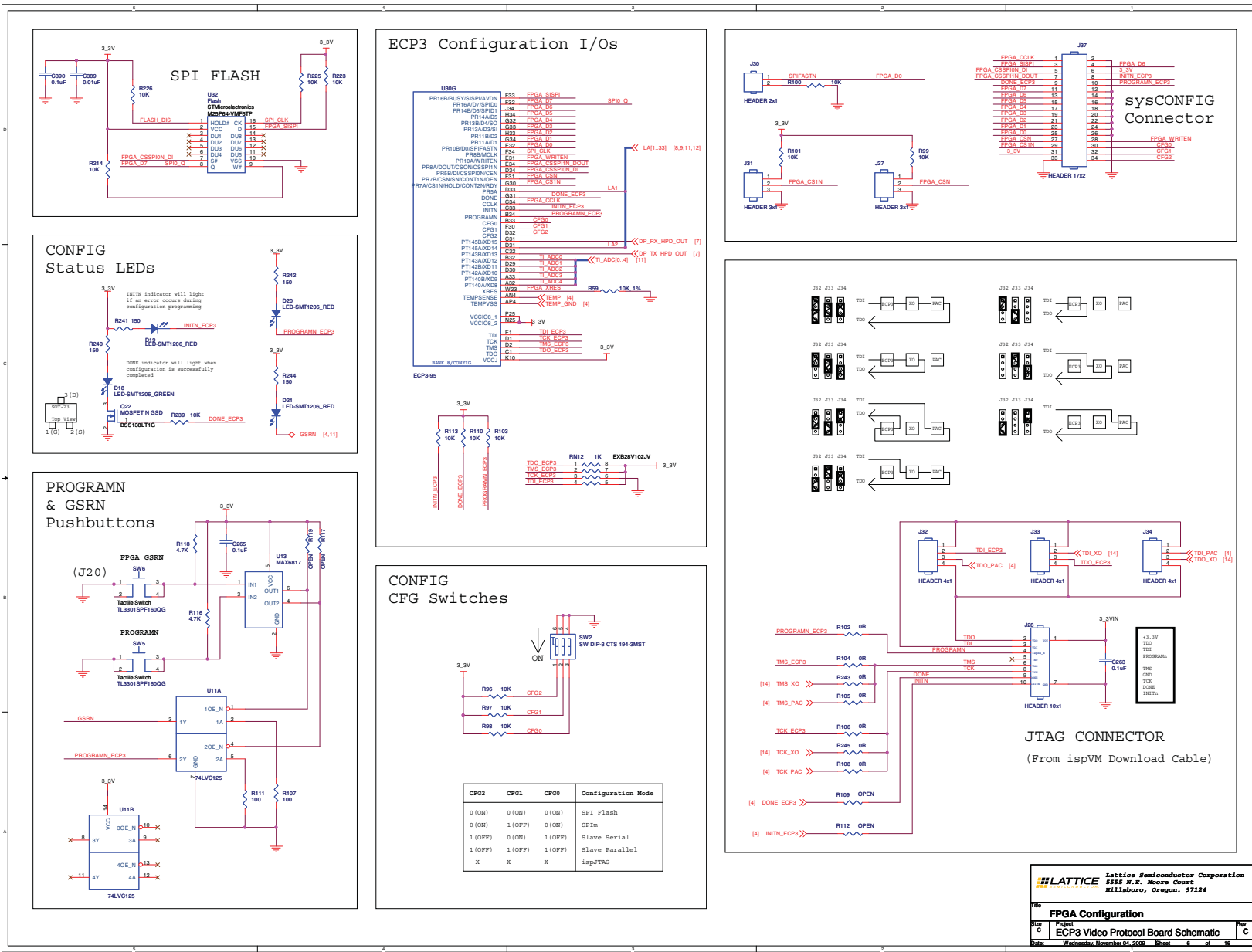
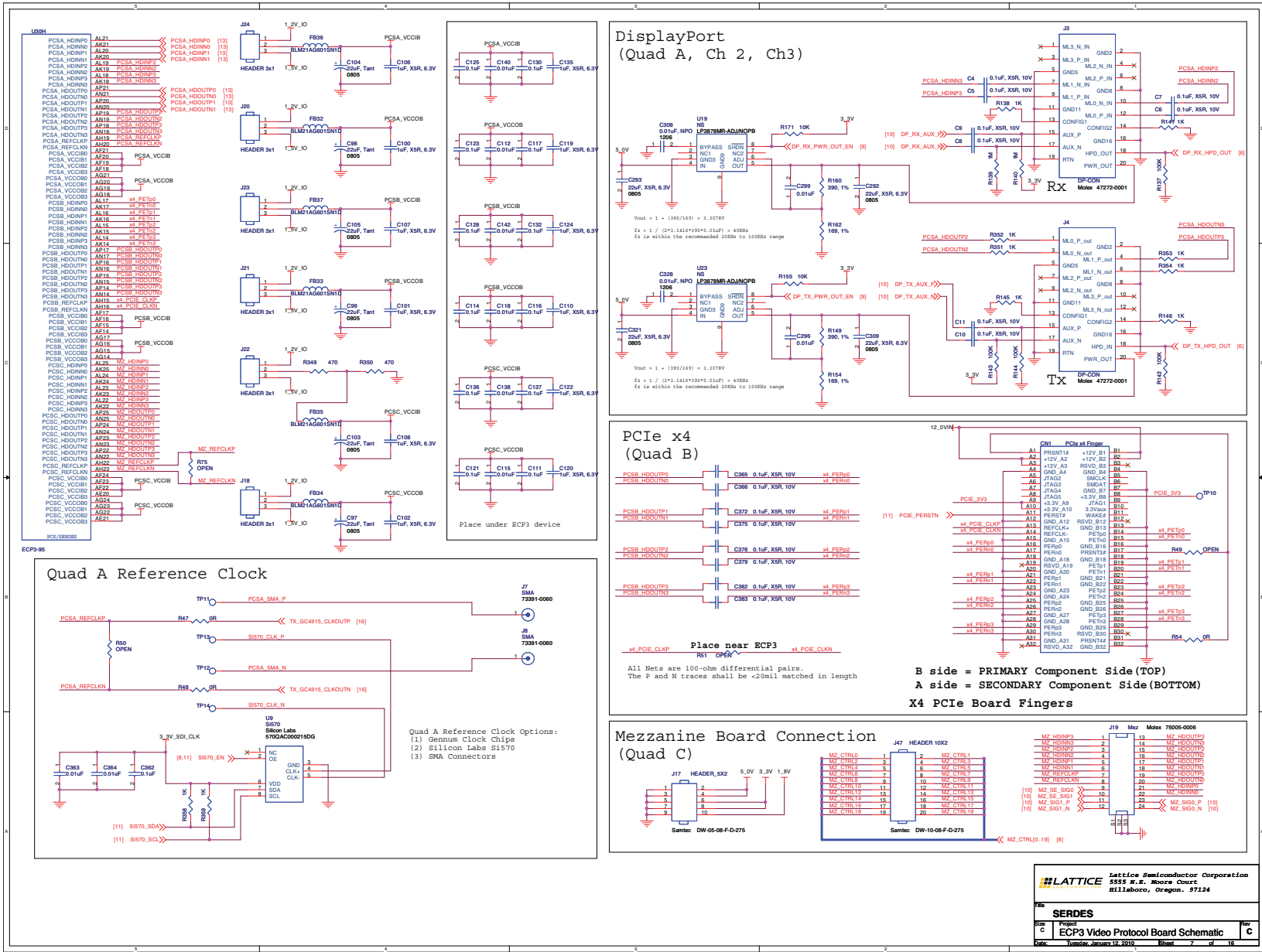

Figure 16. SERDES



Lattice Semiconductor Corporation  
5555 N.E. Moore Court  
Hillsboro, Oregon, 97124

SERDES	
ECP3 Video Protocol Board Schematic	
Date:	Tuesday, January 12, 2010
Sheet:	7 of 18





Figure 18. DVI/LCD/RS-232

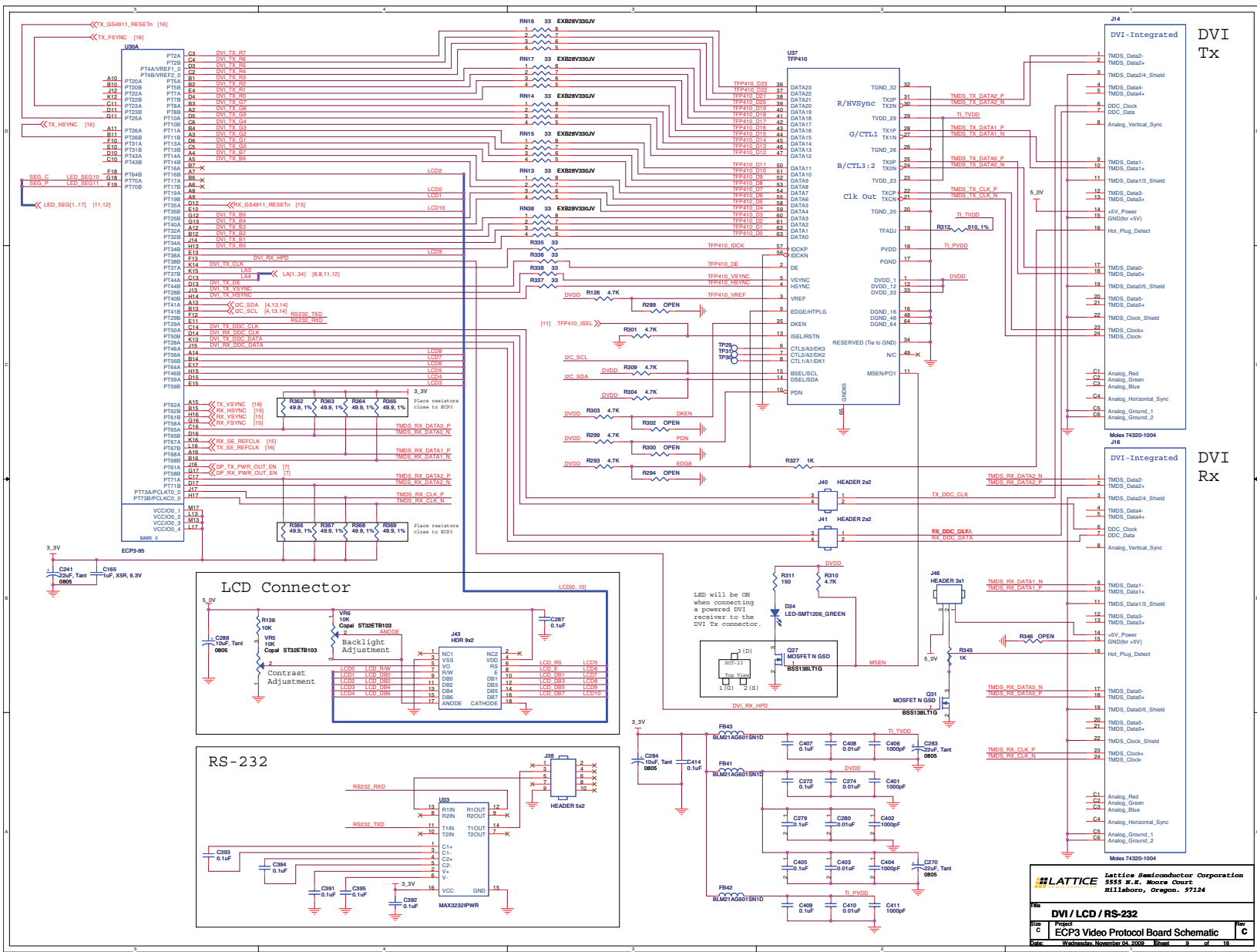
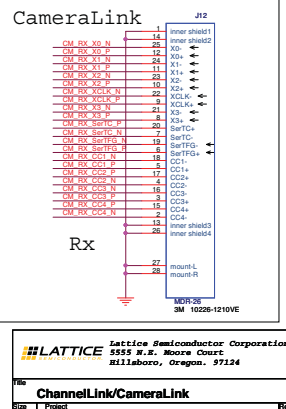
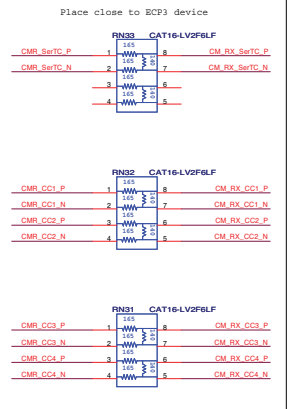
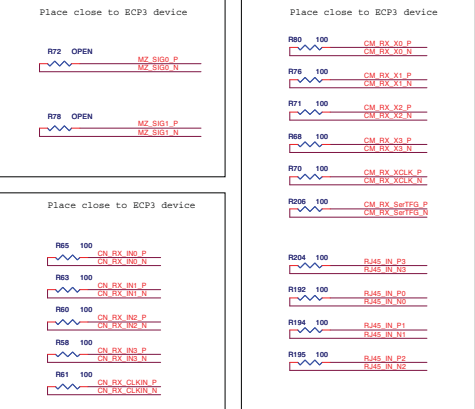
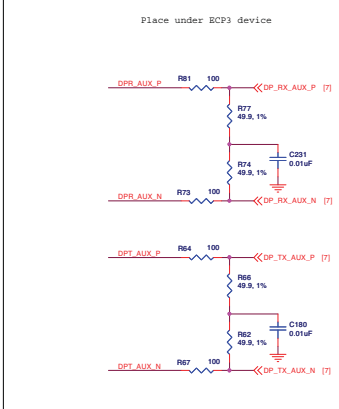
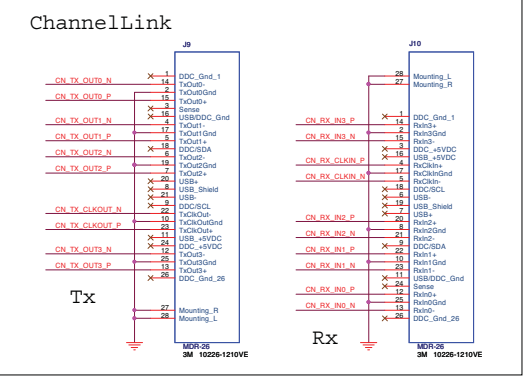
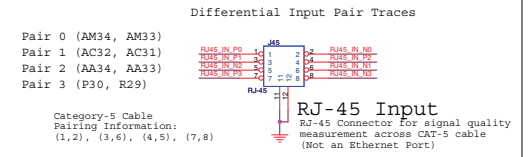
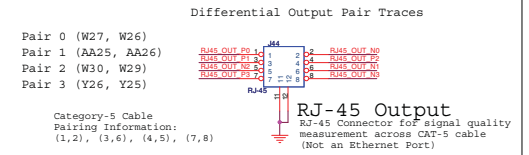
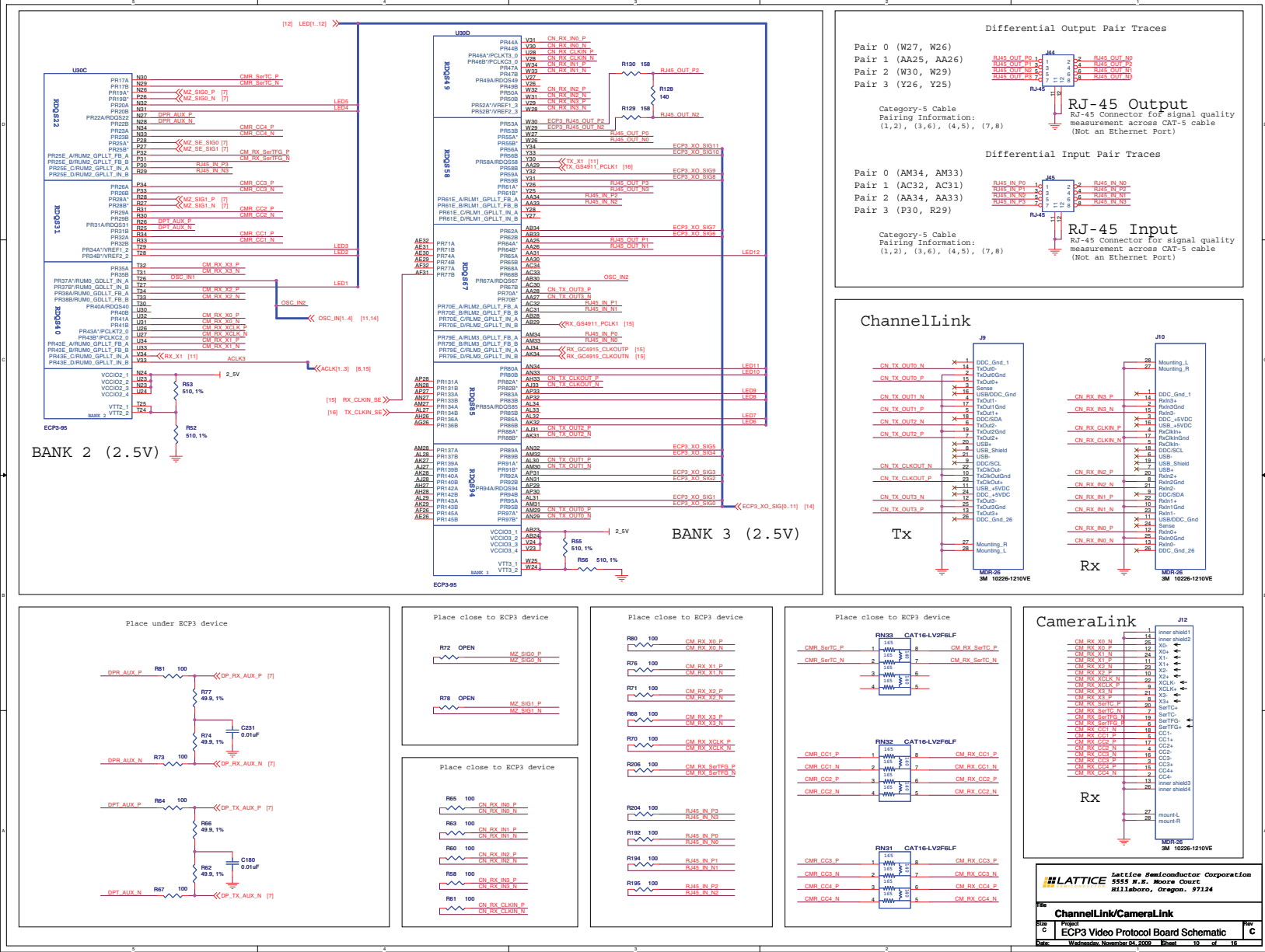

Figure 19. ChannelLink/CameraLink



Lattice Semiconductor Corporation  
5555 N.E. Moore Court  
Hillsboro, Oregon, 97124

ChannelLink/CameraLink

Project: ECP3 Video Protocol Board Schematic

Date: Wednesday, November 04, 2009 Sheet 10 of 18

Figure 20. TI-ADC/Clocks

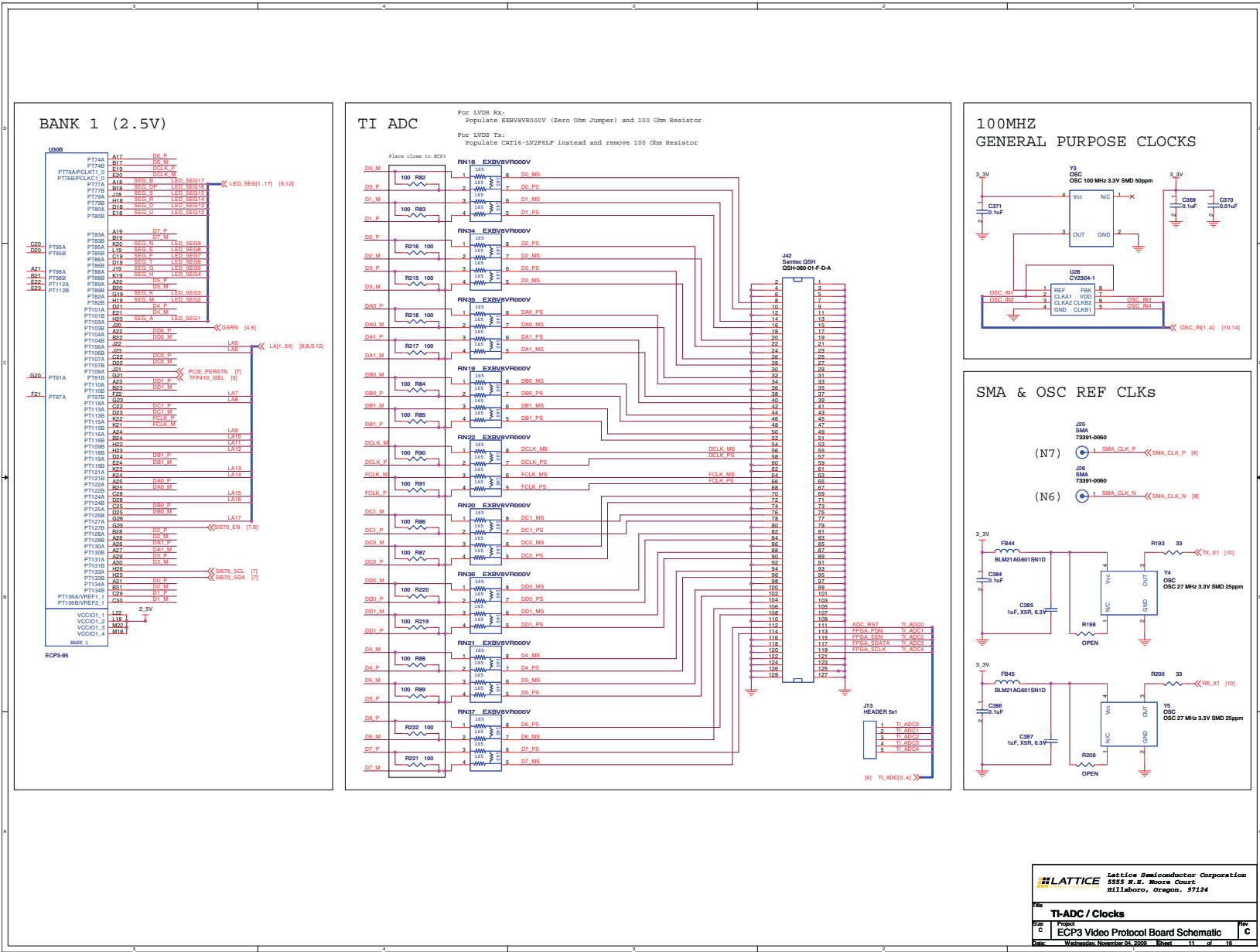

Figure 21. LEDs/Switches/LA Probe

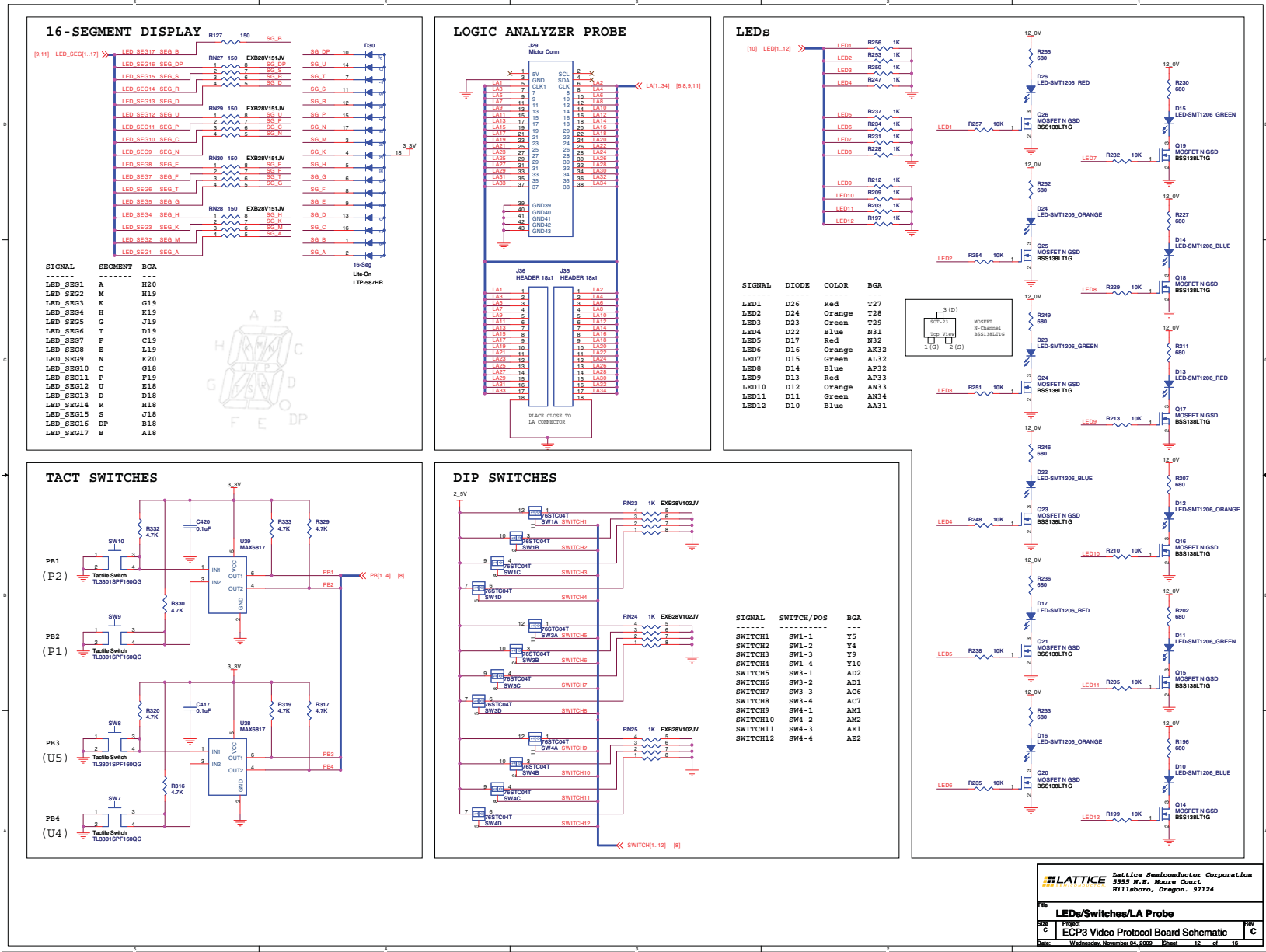
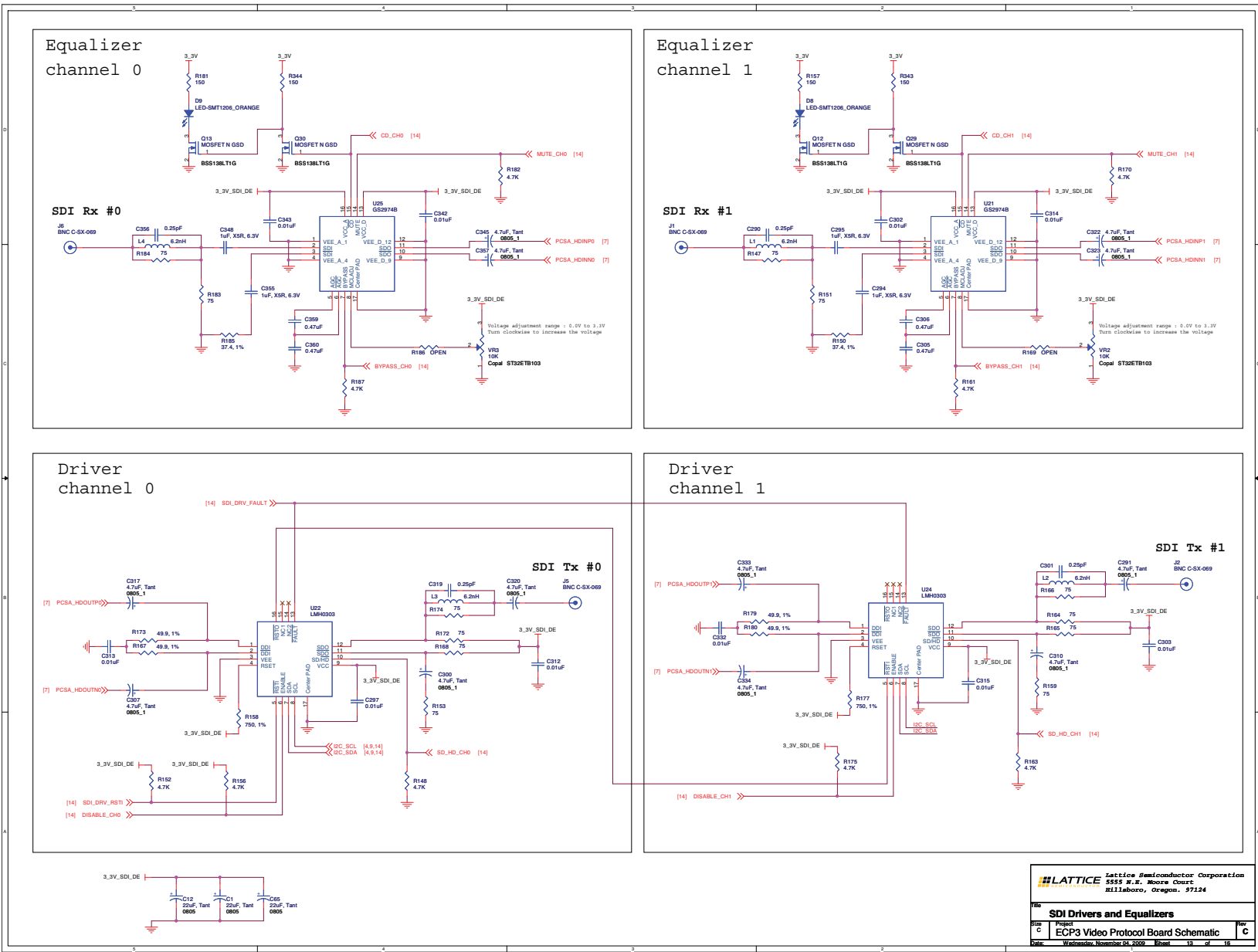

Figure 22. SDI Drivers and Equalizers



<b>LATTICE</b> Lattice Semiconductor Corporation 5555 N.E. Moore Court Hillsboro, Oregon, 97124	
<b>SDI Drivers and Equalizers</b>	
Doc ID: 72982	Rev: C
ECP3 Video Protocol Board Schematic	
Date: Wednesday, November 04, 2009 10:09 AM	Page: 13 of 18







