

Demonstration System EPC9515 Quick Start Guide

*6.78 MHz, 10 W, 5 V Regulated Wireless Power Receiver
using EPC2019*

Revision 2.0



DESCRIPTION

The EPC9515 demonstration board is a 6.78 MHz (Lowest ISM band) highly resonant wireless power receiver capable of delivering up to 10 W as a 5 V regulated output when operating to the AirFuel™ standard (excluding the BLE communications). This board is intended to power products such as mobile devices when used in a wireless power system.

The EPC9515 includes a Category 4 AirFuel Alliance compliant device coil and circuit with high frequency Schottky diode based full bridge rectifier, DC smoothing capacitor and 5 V regulator. The regulator is based on a SEPIC converter that features a 200 V EPC2019 eGaN® FET. The power circuit is attached to the back side of the coil which is provided with a ferrite shield that prevents the circuit from shunting the coil's magnetic field. A photo of the EPC9515 is shown in figure 1.

For more information on the EPC2019 eGaN FETs, please refer to the datasheets available from EPC at www.epc-co.com. The datasheet should be read in conjunction with this quick start guide.

Symbol	Parameter	Conditions	Min	Max	Units
V_{Unreg}	Un-regulated output voltage			38	V
I_{Unreg}	Un-regulated output current			2 [#]	A
V_{Unreg_UVLOR}	UVLO enable	Un-regulated voltage rising		10.96	V
V_{Unreg_UVLOF}	UVLO disable	Un-regulated voltage falling	5.96		V
V_{OUT}	Output voltage range	$V_{Unreg_min} = 8.3\text{ V}$	4.8	5.1	V
I_{OUT}	Output current range	$V_{Unreg_min} = 8.3\text{ V}$	0	2 [#]	A

*Actual maximum current subject to operating temperature limits.

DETAILED DESCRIPTION

The schematic diagram of the EPC9515 is shown in figure 2 and comprises a tuning circuit for the device coil with a common-mode choke for EMI suppression, a high frequency rectifier and SEPIC converter based output regulator. The EPC9515 is powered using a Category 4 AirFuel compliant device coil and by default is tuned to 6.78 MHz for the specific coil provided with it. The tuning circuit comprises both parallel and series tuning which is also differential to allow balanced connection and voltage reduction for the capacitors.



Coil side



Component side

Photo of the EPC9515 receiver board.

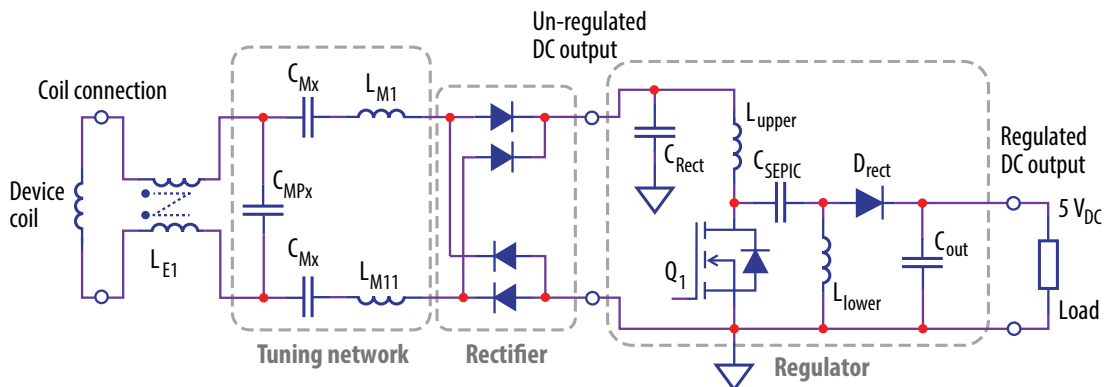

Figure 2: Schematic diagram of the EPC9515 demo board.

Two LEDs have been provided to indicate that the board is receiving power with an un-regulated voltage greater than 4 V (**green LED**) and the **red LED** will illuminate when the un-regulated voltage exceeds 36 V.

The EPC9515 has limited over-voltage protection using a TVS diode that clamps the un-regulated voltage to 38 V. This can occur when the receive coil is placed above a high power transmitter with insufficient distance to the transmit coil and there is little or no load connected. During an over-voltage event, the TVS diode will dissipate a large amount of power and the **red LED** will illuminate indicating an over-voltage. The receiver should be removed from the transmitter as soon as possible to prevent the TVS diode from over-heating.

The EPC9515 can be operated with or without the regulator. The regulator can be disabled by inserting a jumper into position JP50 and connecting the load to the unregulated output terminals. In regulated

mode, the design of the EPC9515 controller will ensure stable operation in a wireless power system. The regulator operates at 280 kHz and the controller features over current protection that limits the load current to 2 A.

The EPC9515 device boards come equipped with kelvin connections for easy and accurate measurement of the un-regulated and regulated output voltages. The rectified voltage current can also be measured using the included shunt resistor. In addition, the EPC9515 has been provided with a switch-node measurement connection for low inductance connection to an oscilloscope probe that yields reliable waveforms.

The EPC9515 is designed to operate in conjunction with EPC9128 (16 W EPC9509), and EPC9120 (33 W EPC9512) transmitters units.

Figure 3 shows the proper connection method to the EPC9515.

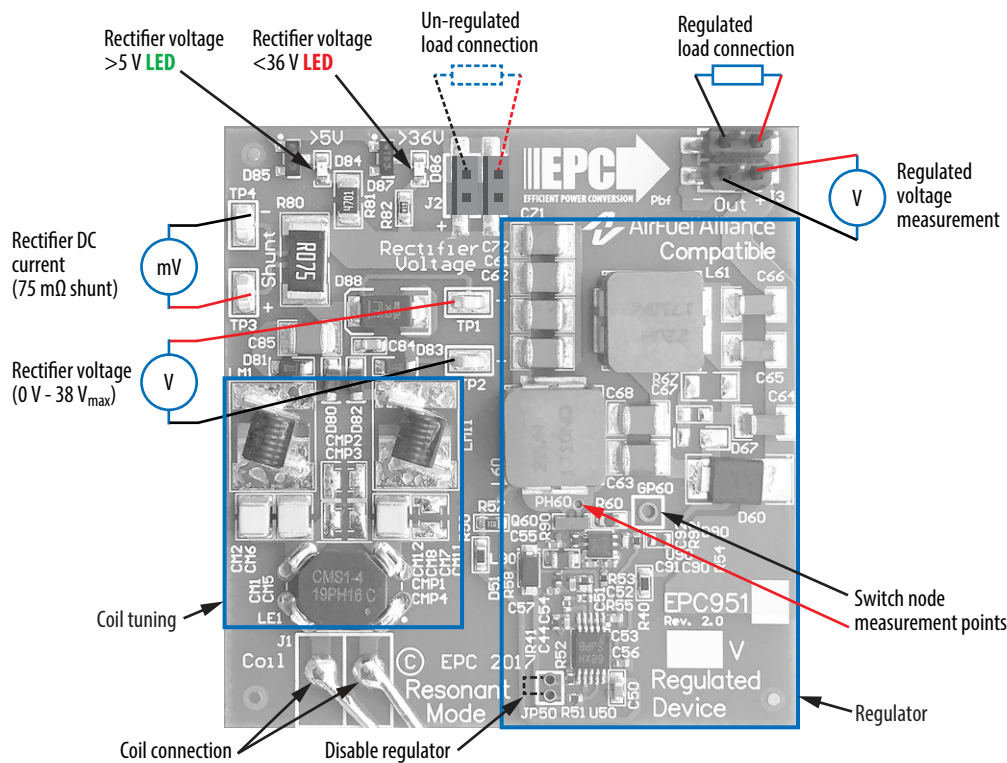

Figure 3: Proper connection and measurement setup for the receiver board.

QUICK START PROCEDURE

The EPC9515 demonstration system is easy to set up and evaluate the performance of the eGaN FET in a wireless power transfer application. Refer to figure 3 for proper connection and measurement setup before following the testing procedures.

The EPC9515 can be operated using any one of two alternative methods:

- a. Using the regulator
- b. Bypassing the regulator

a. Operation using the regulator

In this mode, the regulator is used to provide a fixed output voltage of 5 V for the wireless power receiver and will limit the output current to 2 A.

1. Make sure the entire system is fully assembled (this includes the wireless power transmitter) prior to making electrical connections and make sure jumper JP50 is NOT installed. Connect the load to the regulated output and connect all required instrumentation according to figure 3.
2. Power up the wireless power transmitter and observe that the EPC9515 receives power via the **green LED**, un-regulated voltage and output voltage.
3. Once operation has been confirmed, observe the output voltage and other parameters on the device board.
4. For shutdown, please follow steps in the reverse order.

b. Bypassing the regulator

In this mode, the regulator is disabled and the load connected directly to the un-regulated output of the board. There is no protection against over-current in this mode.

1. Make sure the entire system is fully assembled (this includes the wireless power transmitter) prior to making electrical connections and make sure jumper JP50 is installed. Connect the load to the un-regulated output and connect all required instrumentation according to figure 3 (where applicable).
2. Power up the wireless power transmitter and observe that the EPC9515 receives power via the **green LED**, un-regulated voltage and output voltage.

3. Once operation has been confirmed, observe the output voltage and other parameters on the device board.
4. For shutdown, please follow steps in the reverse order.

Measurement Notes:

When measuring the high frequency content such as the switch-node, care must be taken to avoid long ground leads. An oscilloscope probe connection (preferred method) has been built into the board to simplify the measurement of the switch-node voltage (shown in figure 3).

Pre-Cautions

The EPC9515 demonstration system has limited enhanced protection systems (thermal and electrical) and therefore should be operated with caution. Some specific precautions are:

1. Never operate the EPC9515 receiver with a transmitter that is AirFuel **compliant** as this system does not communicate with the source to correctly setup the required operating conditions and doing so may lead to a failure. Please contact EPC at info@epc-co.com should operating the system with an AirFuel compliant device be required to obtain instructions on how to do this.
2. There is no heat-sink on the devices and during experimental evaluation it is possible present conditions to the regulator that may cause the device to overheat. Always check operating conditions and monitor the temperature of the EPC devices using an IR camera.
3. Never connect the EPC9515 device board into your VNA in an attempt to measure the input impedance. Doing so can severely damage the VNA.
4. Please contact EPC at info@epc-co.com should the tuning of the coil be required to change to suit specific conditions so that it can be correctly adjusted for use with this board.

Thermal Considerations

The EPC9515 demonstration system showcases the EPC2019 eGaN FETs in a wireless energy transfer application. Although the electrical performance surpasses that of traditional silicon devices, their relatively smaller size does magnify the thermal management requirements. The operator must observe the temperature of the gate driver and eGaN FET to ensure that both are operating within the thermal limits as per the datasheets.



EPC would like to acknowledge Würth Elektronik (www.we-online.com) for their support of this project.

Würth Elektronik is a premier manufacturer of electronic and electromechanical passive components. EPC has partnered up with Würth Elektronik for a variety of passive component requirements due to the performance, quality and range of products available. The EPC9515 development board features various Würth Elektronik product lines including capacitors, LEDs and connectors.

Also featured on the board are numerous Würth Elektronik power inductor technologies including WE-AIR air core inductors. The inductors were chosen for their balance between size, efficiency, current handling capability, reliability, and lowest DCR losses.

Learn more at www.we-online.com.

Table 2: Bill of Materials - Rev 2.0

Item	Qty	Reference	Part Description	Manufacturer	Part #
1	1	C44	Capacitor, 100 pF, 25 V	Würth	885012205038
2	1	C50	Capacitor, 100 nF, 100 V	Murata	GRM188R72A104KA35D
3	1	C51	Capacitor, 4.7 µF, 6.3 V	Murata	GRM155R60J475ME47D
4	1	C52	Capacitor, 100 pF, 50 V	Murata	GRM1555C1H101JA01D
5	1	C53	Capacitor, 220 pF, 50 V	Murata	GRM155R71H221KA01D
6	2	C55, C90	Capacitor, 1 µF, 25 V	TDK	C1005X5R1E105M050BC
7	3	C56, C57, C91	Capacitor, 100 nF, 16 V	Würth	885012205037
8	7	C61, C62, C63, C68, C71, C72, C85	Capacitor, 10 µF, 50 V	Taiyo Yuden	UMK325BJ106MM-T
9	3	C64, C65, C66	Capacitor, 22 µF, 35 V	TDK	C3216JB1V226M160AC
10	1	C84	Capacitor, 100 nF, 50 V	Würth	885012206095
11	1	C92	Capacitor, 22 pF, 50 V	Würth	885012005057
12	4	CM1, CM2, CM11, CM12	Capacitor, 470 pF size 1111	Johanson	VJ1111D561KXDAT
13	1	D51	Schottky Diode, 30 V, 500 mA	ST	STPS0530Z
14	1	D60	Schottky Diode, 100 V, 3 A	ST	STPS3H100UF
15	4	D80, D81, D82, D83	Schottky Diode, 40 V, 1 A	Diodes Inc.	PD3S140-7
16	1	D84	LED 0603 Green	Lite-On	LTST-C193KGKT-5A
17	1	D85	Zener Diode, 2.7 V, 250 mW	NXP	BZX84-C2V7,215
18	1	D86	LED 0603 Red	Lite-On	LTST-C193KRKT-5A
19	1	D87	Zener Diode, 33 V, 250 mW	NXP	BZX84-C33,215
20	1	D88	TVS Diode, 35 V, 8.2 A	Littelfuse	SMAJ30A
21	1	J1	Category 4 Coil	NuCurrent	NC20-R064M10E-112-066-1R27
22	1	J3	.1" Male Vert. SMD 2 x 2	Amphenol FCI	95278-101A04LF
23	2	L60, L61	Inductor, 22 µH, 4.3 A	Vishay Dale	IHLP3232DZER220M11
24	1	L90	Inductor, 10 µH, 150 mA	Taiyo Yuden	LBR2012T100K
25	1	LE1	Inductor, 18 µH, 3.8 mA	Eaton	CMS1-4-R
26	2	LM1, LM11	Inductor, 82 nH	Würth	744912182
27	1	Q60	eGaN FET, 200 V, 9 A, 43 mΩ	EPC	EPC2019
28	1	R40	Resistor, 17.8 k Ω 1%, 1/10W	Panasonic	ERJ-3EKF1782V
29	1	R41	Resistor, 6.04 k Ω 1%, 1/10W	Panasonic	ERJ-2RKF6041X
30	1	R50	Resistor, 10 Ω 1%, 1/10W	Panasonic	ERJ-3EKF10R0V
31	1	R51	Resistor, 124 k Ω 1%, 1/10W	Panasonic	ERJ-2RKF1243X
32	1	R52	Resistor, 62 k Ω 1%, 1/10W	Panasonic	ERJ-2RKF6202X
33	1	R53	Resistor, 12 Ω 1%, 1/10W	Panasonic	ERJ-2RKF12R0X
34	1	R54	Resistor, 0 Ω JUMPER, 1/16W	Yageo	RC0402JR-070RL
35	1	R57	Resistor, 1 mΩ 1%, 1/10W	Panasonic	ERJ-3EKF1004V
36	1	R58	Resistor, 150 k Ω 1%, 1/10W	Panasonic	ERJ-2RKF1503X

Table 2: Bill of Materials - Rev 2.0 (cont.)

Item	Qty	Reference	Part Description	Manufacturer	Part #
37	1	R60	Resistor, 40 mΩ 1%, 0.4W	Vishay Dale	WSLP0603R0400FEB
38	1	R80	Resistor, 75 mΩ 1%, 2W	Stackpole	CSRN2512FK75L0
39	1	R81	Resistor, 4.7 kΩ 1%, 1/4W	Stackpole	RMCF1206FT4K70
40	1	R82	Resistor, 422 Ω 1%, 1/10W	Yageo	RMCF0603FT422R
41	1	R90	Resistor, 2.2 Ω 5%, 1/16W	Yageo	RC0402JR-072R2L
42	1	R92	Resistor, 20 Ω 5%, 1/16W	Stackpole	RMCF0402JT20R0
43	4	TP1, TP2, TP3, TP4	SMD Probe Loop	Keystone	5015
44	1	U50	IC, Boost Controller	Texas Instruments	LM3481MM/NOPB
45	1	U90	IC, Gate Driver with LDO	Texas Instruments	UCC27611DRV

Table 3: Optional Components

Item	Qty	Reference	Part Description	Manufacturer	Part #
1	1	C54	Capacitor, 0.022 μF, 50 V, X7R	Murata	GRM155R71H223KA12D
2	1	C67	Capacitor, 10 nF, 100 V, X7R	TDK	C1608X7R2A103K080AA
3	6	CM5, CM6, CM7, CM8, CMP3, CMP4	Capacitor RF Size 0505 (B)	TBD	TBD
4	2	CMP1, CMP2	Capacitor RF Size 1111 (B)	TBD	TBD
5	1	D67	Schottky Diode, 200 V	Diodes Inc.	DFLS1200
6	1	D90	Zener Diode, 5.1 V, 150 mW	Comchip Technology	CZRU52C5V1
7	1	GP60	CONN HEADER 1 POS 2.54	Würth	61300111121
8	1	J2	.1" Male Vert. SMD 2 x 2	Amphenol FCI	95278-101A04LF
9	1	JP50	.05" 2 pos Male Vert Connector	Sullins	GRPB021VWVN-RC
10		R67	Resistor, 10 k Ω 5%, 2/3W	Panasonic	ERJ-P08J103V
11	1	R55	Resistor, 23.2 k Ω 1%, 1/10W	Panasonic	ERJ-2RKF2322X

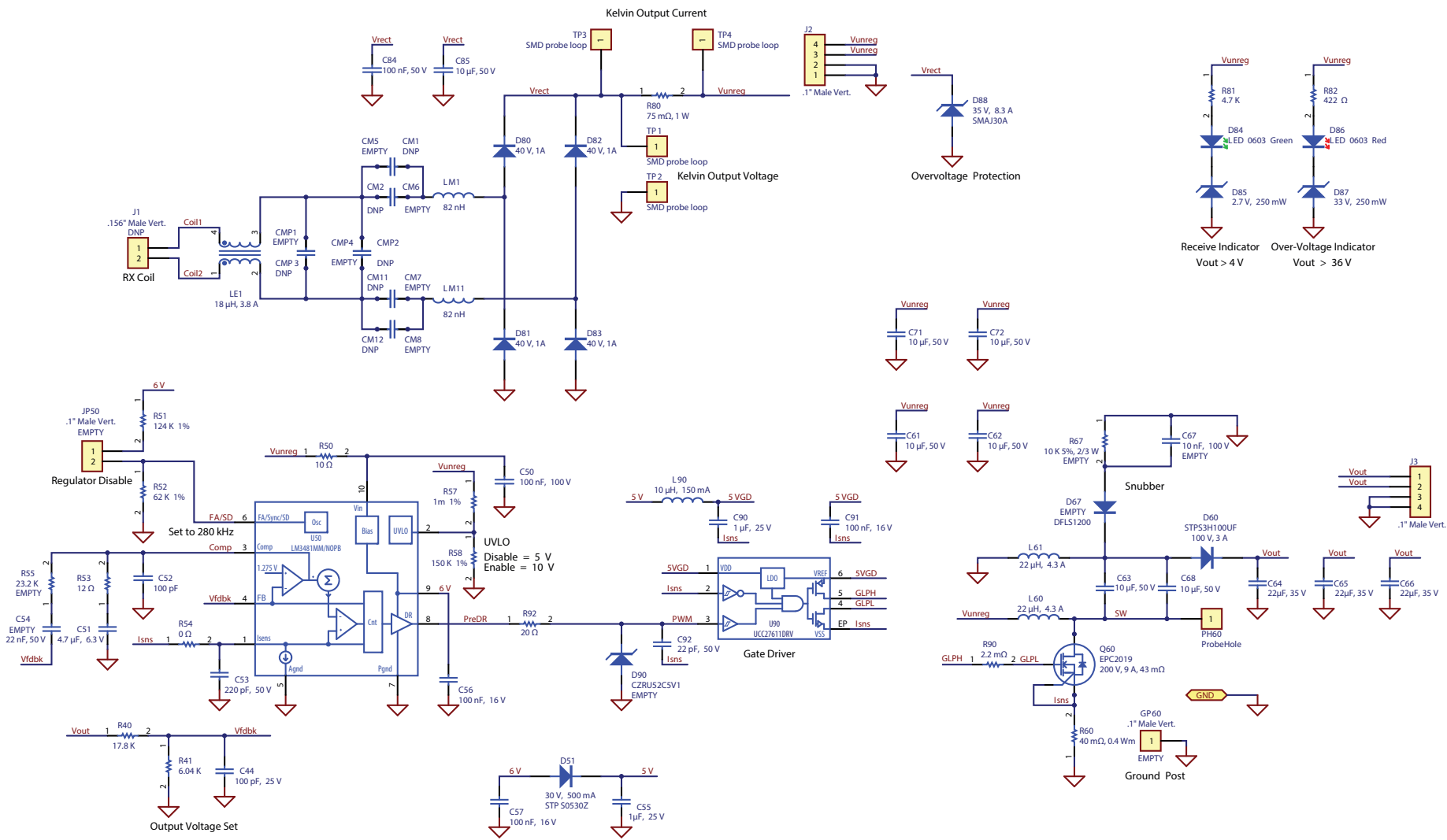

Figure 4: EPC9515 Schematic

For More Information:

Please contact info@epc-co.com
or your local sales representative

Visit our website:
www.epc-co.com

Sign-up to receive
EPC updates at
bit.ly/EPCupdates
or text "EPC" to 22828



EPC Products are distributed through Digi-Key.

www.digikey.com

Demonstration Board Warning and Disclaimer

The EPC9515 board is intended for product evaluation purposes only and is not intended for commercial use. Replace components on the Evaluation Board only with those parts shown on the parts list (or Bill of Materials) in the Quick Start Guide. Contact an authorized EPC representative with any questions.

This board is intended to be used by certified professionals, in a lab environment, following proper safety procedures. Use at your own risk.

As an evaluation tool, this board is not designed for compliance with the European Union directive on electromagnetic compatibility or any other such directives or regulations. As board builds are at times subject to product availability, it is possible that boards may contain components or assembly materials that are not RoHS compliant. Efficient Power Conversion Corporation (EPC) makes no guarantee that the purchased board is 100% RoHS compliant.

The Evaluation board (or kit) is for demonstration purposes only and neither the Board nor this Quick Start Guide constitute a sales contract or create any kind of warranty, whether express or implied, as to the applications or products involved.

Disclaimer: EPC reserves the right at any time, without notice, to make changes to any products described herein to improve reliability, function, or design. EPC does not assume any liability arising out of the application or use of any product or circuit described herein; neither does it convey any license under its patent rights, or other intellectual property whatsoever, nor the rights of others.