

White LED Step-Up Converter in SOT23

General Description

The MAX1848 drives white LEDs with a constant current to provide backlight in cell phones, PDAs, and other hand-held devices. The step-up converter topology allows series connection of the white LEDs so that the LED currents are identical for uniform brightness. This configuration eliminates the need for ballast resistors and expensive factory calibration. Other benefits include greater simplicity, lower cost, higher efficiency, and greater reliability.

This step-up PWM converter includes an internal, high-voltage, low $R_{DS(on)}$ N-channel MOSFET switch for high efficiency and maximum battery life. A single analog voltage Dual Mode™ input provides a simple means of brightness adjustment and on/off control. Fast 1.2MHz current-mode PWM control allows for small input and output capacitors and a small inductor while minimizing ripple on the input supply/battery. Programmable soft-start eliminates inrush current during startup.

The MAX1848 is available in space-saving 8-pin thin QFN (3mm × 3mm) and 8-pin SOT23 packages.

Applications

Cell Phones and Smart Phones
 PDAs, Palmtops, and Wireless Handhelds
 e-Books and Subnotebooks
 White LED Display Backlighting

Typical Application Circuit

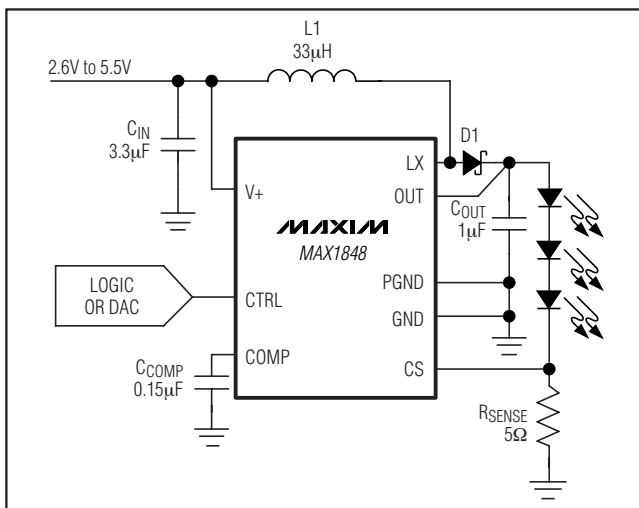

Features

- ◆ Constant Current Regulation for Uniform Illumination
- ◆ High 87% Efficiency
- ◆ Analog or Logic Control of LED Intensity
- ◆ 0.8W Output Power with Internal High-Voltage MOSFET Switch
- ◆ Small, Low-Profile External Components
- ◆ 2.6V to 5.5V Input Range
- ◆ 13V Maximum Output with Overvoltage Protection
- ◆ Optimized for Low Input Ripple
- ◆ Programmable Soft-Start
- ◆ 0.3µA Shutdown Current
- ◆ Small 8-pin Thin QFN (3mm × 3mm) and 8-Pin SOT23 Packages

Ordering Information

PART	TEMP RANGE	PIN-PACKAGE	TOP MARK
MAX1848EKA-T	-40°C to +85°C	8 SOT23	AAIM
MAX1848ETA-T	-40°C to +85°C	8 Thin QFN (3mm × 3mm)	ACR
MAX1848ETA+T	-40°C to +85°C	8 Thin QFN (3mm × 3mm)	ACR

+ Denotes lead-free package.

Note: Hand soldering is not recommended for the MAX1848 SOT23 package.

Pin Configuration

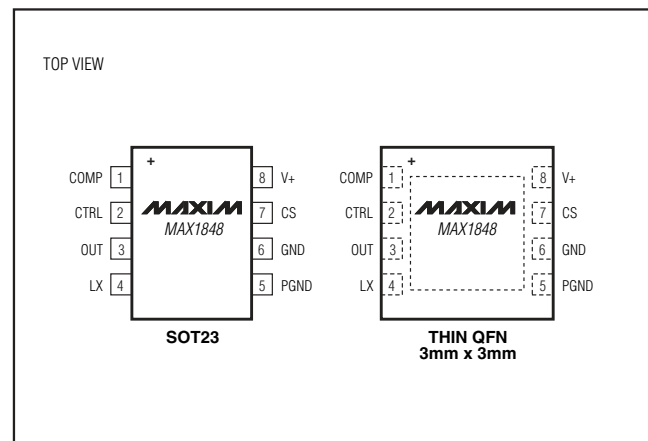

Dual Mode is a trademark of Maxim Integrated Products, Inc.

White LED Step-Up Converter in SOT23

ABSOLUTE MAXIMUM RATINGS

V+ to GND	-0.3V to +6V
PGND to GND	-0.3V to +0.3V
LX, OUT to GND	-0.3V to +14V
LX to OUT	-14V to +0.3V
CTRL to GND	-0.3V to +6V or (V+ + 2V)
COMP, CS to GND	-0.3V to (V+ + 0.3V)
LX Current	0.45A _{RMS}

Continuous Power Dissipation (T _A = +70°C)	
8-Pin SOT23 (derate 9.7mW/°C above +70°C).....	777mW
8-Pin Thin QFN 3mm x 3mm (derate 24.4mW/°C above +70°C).....	1951mW
Operating Temperature Range	-40°C to +85°C
Junction Temperature	+150°C
Storage Temperature Range	-60°C to +150°C
Lead Temperature (soldering, 10s).....	+300°C

Stresses beyond those listed under "Absolute Maximum Ratings" may cause permanent damage to the device. These are stress ratings only, and functional operation of the device at these or any other conditions beyond those indicated in the operational sections of the specifications is not implied. Exposure to absolute maximum rating conditions for extended periods may affect device reliability.

DC ELECTRICAL CHARACTERISTICS

(V+ = 3V, V_{OUT} = 11V, L = 33μH, C_{OUT} = 1μF, C_{COMP} = 0.15μF, R_{SENSE} = 5Ω, V_{CTRL} = 1V, T_A = 0°C to +85°C, unless otherwise noted. Typical values are at T_A = +25°C.)

PARAMETER	CONDITIONS	MIN	TYP	MAX	UNITS	
Supply Voltage		2.6		5.5	V	
Undervoltage Lockout Threshold	V+ rising, 40mV hysteresis typical	2.15	2.38	2.59	V	
	V+ falling	2.10	2.34	2.56		
Quiescent Current	Not switching, V _{CTRL} = V _{CS} = V+		0.25	0.40	mA	
	Switching, V _{CTRL} = V+, V _{CS} = GND		1	2		
Shutdown Supply Current	V _{CTRL} = GND	T _A = +25°C	0.3	1	μA	
		T _A = +85°C	0.3			
Overvoltage Threshold	V+ rising, 1V hysteresis typical	12.5	13.25	14.0	V	
	V+ falling	11.5	12.25	13		
OUT Input Bias Current	V _{OUT} = 13V	V _{CTRL} > 0.25V	10	20	30	μA
		V _{CTRL} = GND		0.01	1	
Output Voltage Range		V+ - V _{DIODE}		12.5	V	
ERROR AMPLIFIER						
CTRL to CS Regulation	V _{CTRL} = 2V, V+ = 2.6V to 5.5V	71	75	81	mV/V	
CS Input Bias Current	V _{CS} = V _{CTRL} / 13.33		0.01	1	μA	
CTRL Input Resistance		450	670	1100	kΩ	
CTRL Dual Mode Threshold	Hysteresis = 25mV typical	100	170	240	mV	
CS Line Regulation	V+ = 2.6V to 5.5V, V _{CTRL} = 3V		0.05		%/V	
COMP Pin Resistance to Ground	Device in shutdown or overvoltage	7.5	15	50	kΩ	
COMP Output Voltage Swing		0.3		2.4	V	
OSCILLATOR						
Operating Frequency		1.0	1.2	1.5	MHz	
Minimum Duty Cycle	PWM mode		12		%	
	Pulse skipping		0			
Maximum Duty Cycle	V _{CTRL} = V+, V _{CS} = GND	85	90	97	%	

White LED Step-Up Converter in SOT23

MAX1848

DC ELECTRICAL CHARACTERISTICS (continued)

($V_+ = 3V$, $V_{OUT} = 11V$, $L = 33\mu H$, $C_{OUT} = 1\mu F$, $C_{COMP} = 0.15\mu F$, $R_{SENSE} = 5\Omega$, $V_{CTRL} = 1V$, $T_A = 0^\circ C$ to $+85^\circ C$, unless otherwise noted. Typical values are at $T_A = +25^\circ C$.)

PARAMETER	CONDITIONS	MIN	TYP	MAX	UNITS
N-CHANNEL SWITCH					
LX On-Resistance	$I_{LX} = 100mA$		1.4	2.2	Ω
LX Leakage Current	$V_{OUT} = V_{LX} = 13V$	$T_A = +25^\circ C$	0.01	2	μA
		$T_A = +85^\circ C$	0.05		
LX Current Limit	Duty cycle = 65%	300	500	750	mA

DC ELECTRICAL CHARACTERISTICS

($V_+ = 3V$, $V_{OUT} = 11V$, $L = 33\mu H$, $C_{OUT} = 1\mu F$, $C_{COMP} = 0.15\mu F$, $R_{SENSE} = 5\Omega$, $V_{CTRL} = 1V$, $T_A = -40^\circ C$ to $+85^\circ C$, unless otherwise noted. (Note 1))

PARAMETER	CONDITIONS	MIN	MAX	UNITS	
Supply Voltage		2.6	5.5	V	
Undervoltage Lockout Threshold	V+ rising, 40mV hysteresis typical	2.15	2.59	V	
	V+ falling	2.10	2.56		
Quiescent Current	Not switching, $V_{CTRL} = V_{CS} = V_+$		0.4	mA	
	Switching, $V_{CTRL} = V_+$, $V_{CS} = GND$		2		
Overvoltage Threshold	V+ rising, 1V hysteresis typical	12.25	14.00	V	
	V+ falling	11.25	13.25		
OUT Input Bias Current	$V_{OUT} = 13V$	$V_{CTRL} > 0.25V$	10	30	μA
		$V_{CTRL} = GND$		1	
Output Voltage Range		$V_+ - V_{DIODE}$	12.25	V	
ERROR AMPLIFIER					
CTRL to CS Regulation	$V_{CTRL} = 2V$, $V_+ = 2.6V$ to $5.5V$	65	85	mV/V	
CS Input Bias Current	$V_{CS} = V_{CTRL}/13.33$		1	μA	
CTRL Input Resistance		450	1100	k Ω	
CTRL Dual Mode Threshold	Hysteresis = 25mV typical	100	240	mV	
COMP Pin Resistance to Ground	Device in shutdown or overvoltage	7.5	50.0	k Ω	
COMP Output Voltage Swing		0.3	2.4	V	
OSCILLATOR					
Operating Frequency		0.9	1.6	MHz	
Maximum Duty Cycle	$V_{CTRL} = V_+$, $V_{CS} = GND$	85	97	%	
N-CHANNEL SWITCH					
LX On-Resistance	$I_{LX} = 100mA$		2.2	Ω	
LX Current Limit	Duty cycle = 65%	225	850	mA	

Note 1: Limits are 100% production tested at $T_A = +25^\circ C$. Limits over the operating temperature range are guaranteed through correlation using statistical quality control (SQC) methods.

White LED Step-Up Converter in SOT23

Typical Operating Characteristics

(See Typical Application Circuit, $V_+ = 3V$, $I_{LED} = 15mA$, $L = 33\mu H$, $C_{OUT} = 1\mu F$, $C_{COMP} = 0.15\mu F$, $R_{SENSE} = 5\Omega$, $C_{CTRL} = 1V$, 2 LEDs, $T_A = +25^\circ C$, unless otherwise noted.)

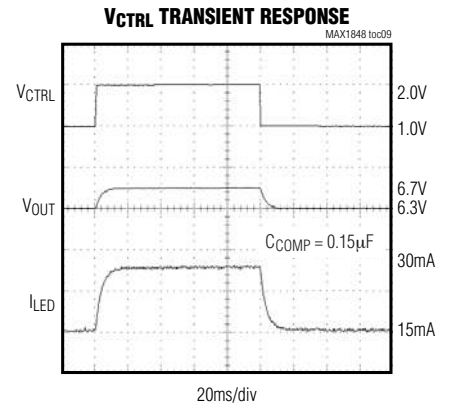
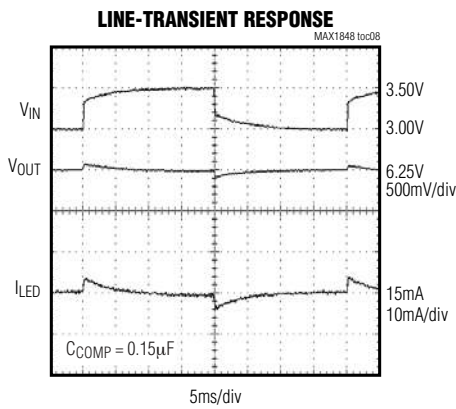
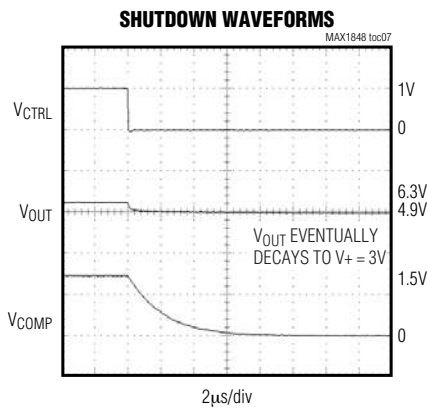
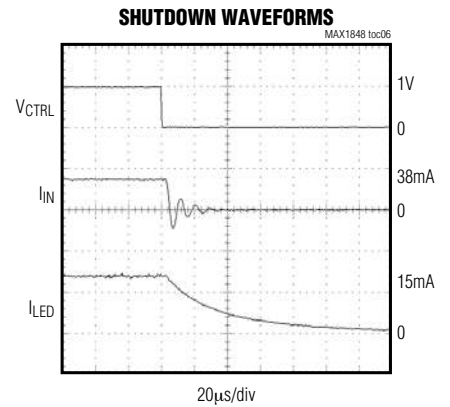
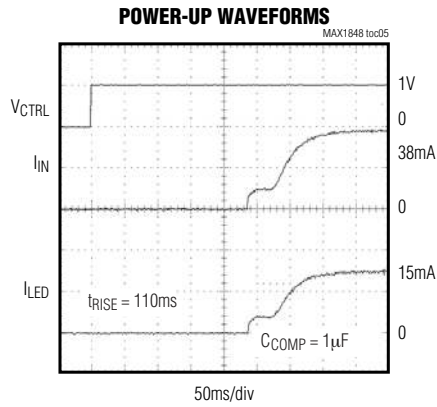
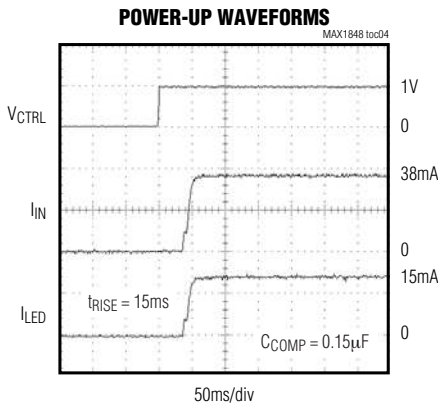
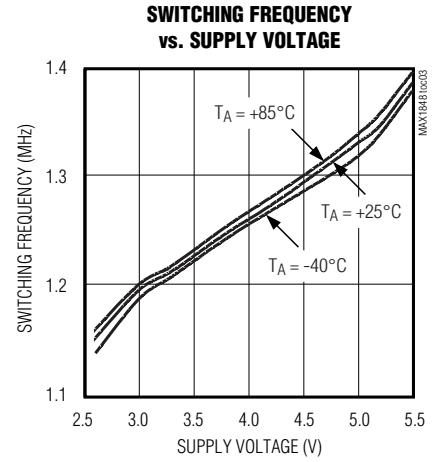
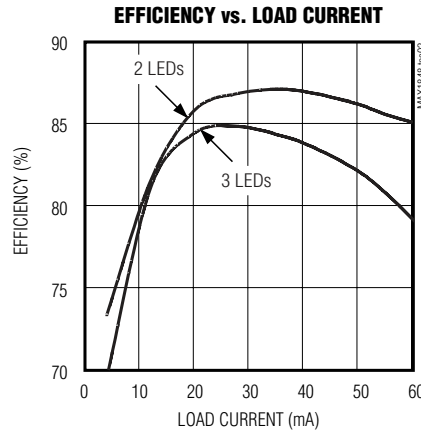
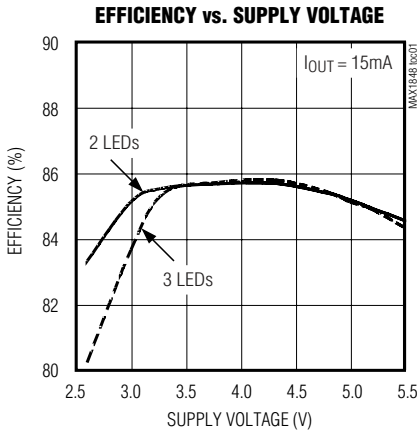

White LED Step-Up Converter in SOT23

MAX1848

Typical Operating Characteristics (continued)

(See Typical Application Circuit, $V_+ = 3V$, $I_{LED} = 15mA$, $L = 33\mu H$, $C_{OUT} = 1\mu F$, $C_{COMP} = 0.15\mu F$, $R_{SENSE} = 5\Omega$, $CTRL = 1V$, 2 LEDs, $T_A = +25^\circ C$, unless otherwise noted.)

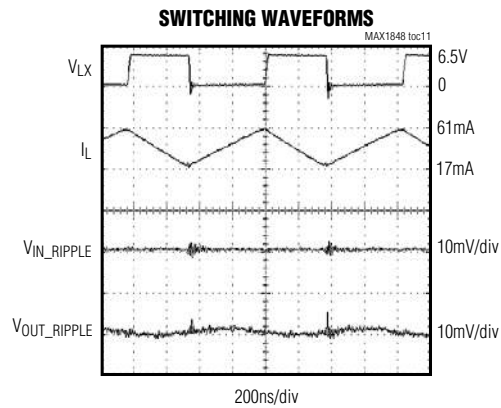
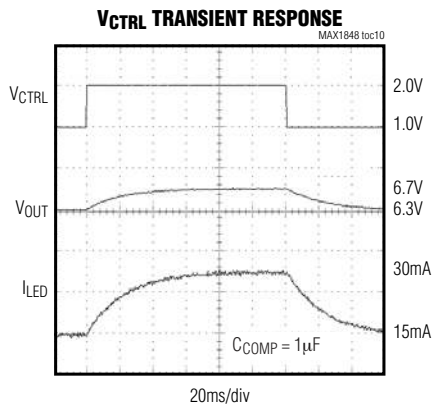

Pin Description

PIN	NAME	FUNCTION
1	COMP	Compensation Pin for Error Amplifier. Connect capacitor from COMP to GND. Startup time is set by the capacitance connected to this pin (0.833ms for each 0.01 μF). V_{COMP} passively discharges to GND when in shutdown.
2	CTRL	Brightness/Shutdown Dual Mode Control Input. LED brightness and IC shutdown are controlled by the voltage on CTRL. Voltages between 250mV and 5.5V or ($V_+ + 2V$), whichever is less, adjust the brightness from dim to bright, respectively. To put the IC into shutdown, drive below 100mV or connect to GND.
3	OUT	Overvoltage Sense. When V_{OUT} is greater than 13.25V, the internal N-channel MOSFET is turned off and V_{COMP} decays to GND. When V_{OUT} drops below 12.25V, the IC will re-enter soft-start. Connect a 1 μF capacitor from OUT to GND.
4	LX	Inductor Connection. Drain of the internal high-voltage N-channel MOSFET.
5	PGND	Power Ground. Source of the internal high-voltage N-channel MOSFET.
6	GND	Ground
7	CS	Current-Sense Feedback Input. Connect a resistor from this pin to GND to set the LED bias current. This pin regulates to 7.5% of V_{CTRL} .
8	V_+	Supply Voltage Input. The IC is powered from this pin. Input range is 2.6V to 5.5V. Bypass with a ceramic capacitor to GND.

White LED Step-Up Converter in SOT23

Detailed Description

The MAX1848's high efficiency and small size make it ideally suited to drive series-connected LEDs. It operates as a boost DC-DC converter that controls output current rather than voltage. The MAX1848 provides even illumination by sending the same output current through each LED, eliminating the need for expensive factory calibration. The fast 1.2MHz internal oscillator allows for a small inductor and small input and output capacitors while minimizing input and output ripple.

The single analog control input allows easy adjustment of LED brightness and on/off control. This allows either simple logic-level on/off control or a DAC to control both brightness and on/off. In shutdown, supply current is reduced to a low 0.3µA. A programmable soft-start gradually illuminates the LEDs, reducing the inrush current during startup.

Soft-Start

The MAX1848 attains soft-start by charging C_{COMP} gradually with a constant 12µA current. When V_{COMP} rises above 1.25V, the internal MOSFET begins switching, but at a reduced duty cycle. When V_{COMP} rises above 2.25V, the duty cycle will be at its maximum.

The maximum startup time is determined by the value of C_{COMP}. For every 0.01µF connected to COMP, the

startup time will increase by 0.833ms. The start time can be calculated by:

$$t_{\text{SOFT-START (MAX)}} = C_{\text{COMP}} \times \frac{1\text{V}}{12\mu\text{A}}$$

Shutdown

The MAX1848 is put into shutdown when V_{CTRL} is less than 100mV. In shutdown, supply current is reduced to 0.3µA by powering down the entire IC except for the CTRL voltage detection circuitry. C_{COMP} is passively discharged during shutdown, allowing the device to re-initiate a soft-start whenever the device is enabled.

When in shutdown, the internal N-channel FET does not switch, which leaves a current path between the input and the LEDs through the boost inductor and Schottky diode. The minimum forward voltage of the LED array must exceed the maximum V₊ to ensure that the LEDs remain off in shutdown. Typical shutdown timing characteristics are shown in the *Typical Operating Characteristics*.

Overvoltage Protection

Overvoltage protection occurs when V_{OUT} is above 13.25V. The protection circuitry stops the internal MOSFET from switching and causes V_{COMP} to decay to GND. The device comes out of overvoltage lockout and into soft-start when V_{OUT} falls below 12.25V.

Design Procedure

Adjusting LED Current

Adjusting the MAX1848's output current will change the brightness of the LEDs. An analog input (CTRL) and the sense resistor value set the output current. Output current is given by:

$$I_{\text{LED}} = \frac{V_{\text{CTRL}}}{13.33 \times R_{\text{SENSE}}}$$

The V_{CTRL} voltage range for adjusting output current is 250mV to (V₊ + 2V) or 5.5V, whichever is less. To set the maximum current, calculate R_{SENSE} when V_{CTRL} is at its maximum. Power dissipation in R_{SENSE} is typically less than 5mW; therefore, a standard chip resistor is sufficient.

Capacitor Selection

The exact values of input and output capacitors are not critical. The typical value for the input capacitor is 3.3µF, and the typical value for the output capacitor is 1.0µF. Larger value capacitors can be used to reduce input and output ripple, but at the expense of size and higher cost.

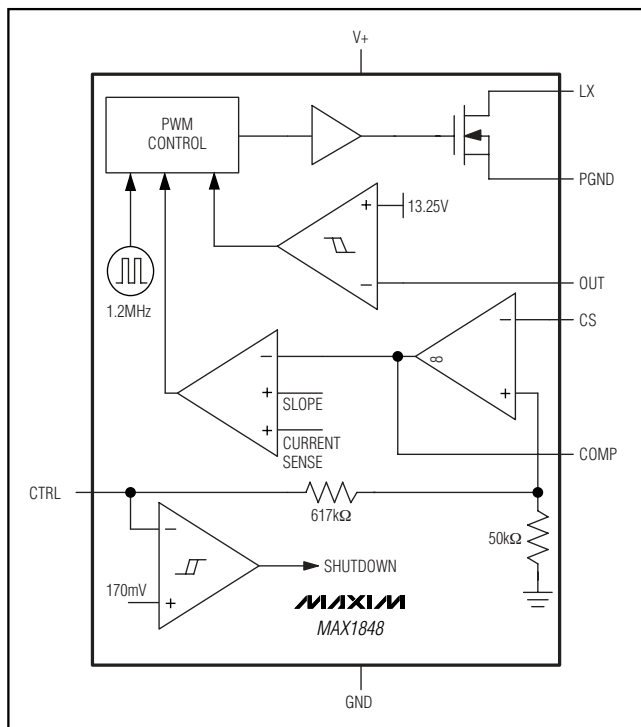

Figure 1. Functional Diagram

White LED Step-Up Converter in SOT23

The output current and the number of LEDs in each leg affect the capacitance of C_{COMP}. Table 1 shows the minimum C_{COMP} values needed to stabilize the converter in worst-case conditions. If further stability analysis is required, note that the error amplifier has 50μA/V transconductance.

Inductor Selection

The value of the inductor depends on the maximum output current to the LEDs. See Table 1 for inductance values and peak current ratings for the inductor.

Schottky Diode Selection

The MAX1848's high-switching frequency demands a high-speed rectification diode. A Schottky diode is required due to their fast recovery time and low forward-voltage drop. Ensure that the diode's average and peak current rating exceed the average output current and peak inductor current, respectively. In addition, the diode's reverse breakdown voltage must exceed V_{OUT}.

$$I_{DIODE(RMS)} = \sqrt{I_{OUT} \times I_{PEAK}}$$

Applications Information

Connecting Four or Six LEDs

The MAX1848 can drive one, two, or three legs of LEDs (Figure 2) as long as the total number of LEDs does not exceed six. Each leg must contain the same number of LEDs and the same sense-resistor value. Adding the second or third leg does not affect the sense-resistor value (see the *Adjusting LED Current* section).

Three legs of two LEDs is more efficient than two legs of three LEDs (see Efficiency Graphs in the *Typical Operating Characteristics*); however, a third sense resistor is needed. Multiple legs can have slight current mismatches due to component tolerances.

Table 1. Component Selection

I _{LED} (mA)	NO. OF LEDs	C _{COMP} (μF)	INDUCTOR	
			L (μH)	I _{PEAK} (mA)
12	3	0.220	56	80
	2	0.100		
20	3	0.150	33	130
	2	0.068		
40	3	0.100	15	260
	2	0.047		
60	3	0.068	10	375
	2	0.01		

PC Board Layout

Due to fast-switching waveforms and high-current paths, careful PC board layout is required. Protoboards and wire-wrap boards should not be used for evaluation. An evaluation kit (MAX1848EV kit) is available to aid design.

When laying out a board, minimize trace lengths between the IC and R_{SENSE}, the inductor, the diode, the input capacitor, and the output capacitor. Keep traces short, direct, and wide. Keep noisy traces, such as the inductor's traces, away from C_S. V₊'s bypass capacitor (C_{IN}) should be placed as close to the IC as possible. PGND and GND should be connected in only one place as close to the IC as possible. The ground connections of C_{IN} and C_{OUT} should be as close together as possible. The traces from V₊ to the inductor and from the Schottky diode to the LEDs may be longer.

Refer to the MAX1848 EV kit for an example of proper layout.

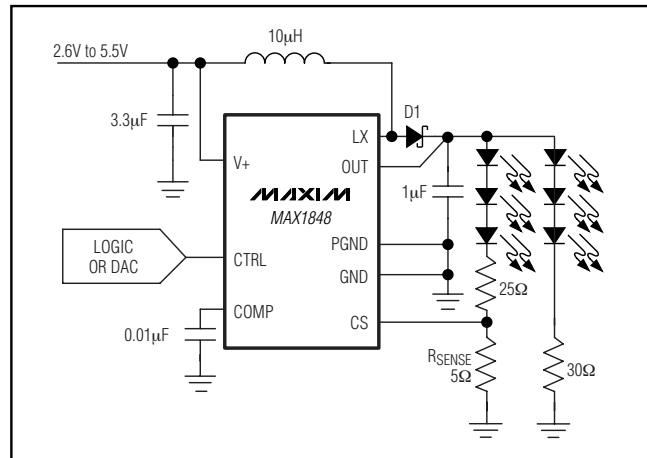

Figure 2. Six LEDs in 3 x 2 Configuration

Chip Information

TRANSISTOR COUNT: 1290

White LED Step-Up Converter in SOT23

Package Information

(The package drawing(s) in this data sheet may not reflect the most current specifications. For the latest package outline information, go to www.maxim-ic.com/packages.)

SEE DETAIL "A"

SYMBOL	MIN	MAX
A	0.90	1.45
A1	0.00	0.15
A2	0.90	1.30
b	0.28	0.45
C	0.09	0.20
D	2.80	3.00
E	2.60	3.00
E1	1.50	1.75
L	0.30	0.60
L2	0.25 BSC.	
e	0.65 BSC.	
e1	1.95 REF.	
θ	0°	8°

DETAIL "A"

NOTE:

- ALL DIMENSIONS ARE IN MILLIMETERS.
- Δ FOOT LENGTH MEASURED FROM LEAD TIP TO UPPER RADIUS OF HEEL OF THE LEAD PARALLEL TO SEATING PLANE C.
- PACKAGE OUTLINE EXCLUSIVE OF MOLD FLASH & METAL BURR.
- PACKAGE OUTLINE INCLUSIVE OF SOLDER PLATING.
- COPLANARITY 4 MILS. MAX.
- PIN 1 I.D. DOT IS 0.3 MM \pm MIN. LOCATED ABOVE PIN 1.
- SOLDER THICKNESS MEASURED AT FLAT SECTION OF LEAD BETWEEN 0.08mm AND 0.15mm FROM LEAD TIP.
- MEETS JEDEC MO178.

DALLAS SEMICONDUCTOR MAXIM
 PROPRIETARY INFORMATION
 TITLE: PACKAGE OUTLINE, SOT-23, 8L BODY
 APPROVAL: DOCUMENT CONTROL NO. 21-0078 REV. D 1/1

SOT23, 8L, EPS

White LED Step-Up Converter in SOT23

Package Information (continued)

(The package drawing(s) in this data sheet may not reflect the most current specifications. For the latest package outline information, go to www.maxim-ic.com/packages.)

MAX1848

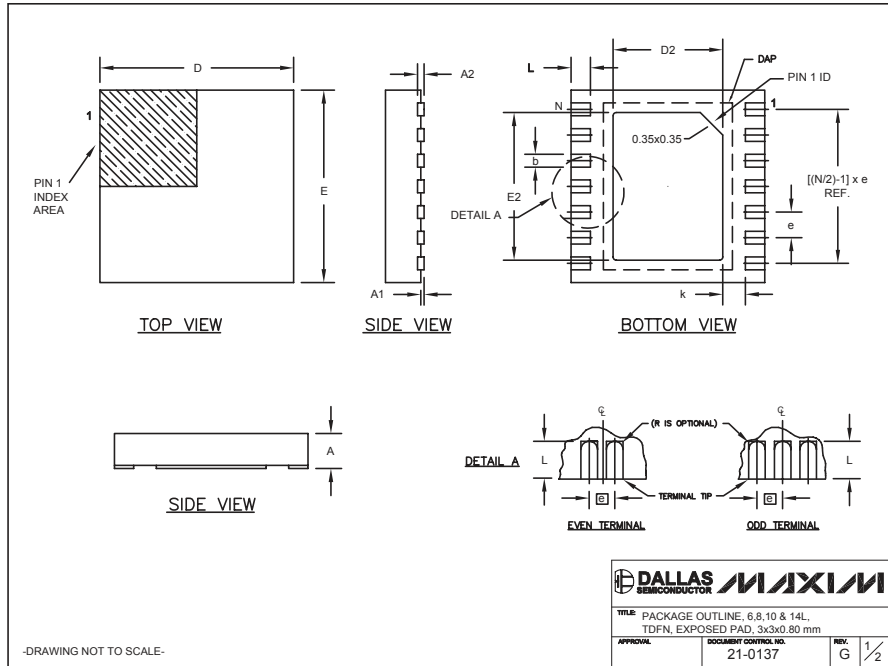

COMMON DIMENSIONS							
SYMBOL	MIN.	MAX.					
A	0.70	0.80					
D	2.90	3.10					
E	2.90	3.10					
A1	0.00	0.05					
L	0.20	0.40					
k	0.25 MIN.						
A2	0.20 REF.						

PACKAGE VARIATIONS								
PKG. CODE	N	D2	E2	e	JEDEC SPEC	b	[(N/2)-1] x e	DOWNBONDS ALLOWED
T633-1	6	1.50±0.10	2.30±0.10	0.95 BSC	MO229 / WEEA	0.40±0.05	1.90 REF	NO
T633-2	6	1.50±0.10	2.30±0.10	0.95 BSC	MO229 / WEEA	0.40±0.05	1.90 REF	NO
T833-1	8	1.50±0.10	2.30±0.10	0.65 BSC	MO229 / WEEC	0.30±0.05	1.95 REF	NO
T833-2	8	1.50±0.10	2.30±0.10	0.65 BSC	MO229 / WEEC	0.30±0.05	1.95 REF	NO
T833-3	8	1.50±0.10	2.30±0.10	0.65 BSC	MO229 / WEEC	0.30±0.05	1.95 REF	YES
T1033-1	10	1.50±0.10	2.30±0.10	0.50 BSC	MO229 / WEED-3	0.25±0.05	2.00 REF	NO
T1433-1	14	1.70±0.10	2.30±0.10	0.40 BSC	----	0.20±0.05	2.40 REF	YES
T1433-2	14	1.70±0.10	2.30±0.10	0.40 BSC	----	0.20±0.05	2.40 REF	NO

NOTES:
 1. ALL DIMENSIONS ARE IN mm. ANGLES IN DEGREES.
 2. COPLANARITY SHALL NOT EXCEED 0.08 mm.
 3. WARPAGE SHALL NOT EXCEED 0.10 mm.
 4. PACKAGE LENGTH/PACKAGE WIDTH ARE CONSIDERED AS SPECIAL CHARACTERISTIC(S).
 5. DRAWING CONFORMS TO JEDEC MO229, EXCEPT DIMENSIONS "D2" AND "E2", AND T1433-1 & T1433-2.
 6. "N" IS THE TOTAL NUMBER OF LEADS.
 7. NUMBER OF LEADS SHOWN ARE FOR REFERENCE ONLY.

DALLAS SEMICONDUCTOR **MAXIM**

TITLE PACKAGE OUTLINE, 6,8,10 & 14L, DFN, EXPOSED PAD, 3x3x0.80 mm

APPROVAL _____ DOCUMENT CONTROL NO. 21-0137 REV. G 2/2

-DRAWING NOT TO SCALE-

Maxim cannot assume responsibility for use of any circuitry other than circuitry entirely embodied in a Maxim product. No circuit patent licenses are implied. Maxim reserves the right to change the circuitry and specifications without notice at any time.

Maxim Integrated Products, 120 San Gabriel Drive, Sunnyvale, CA 94086 408-737-7600 _____ **9**