

CC901F-WL-TYPE 4X COMPACT CABINET COOLER AIR-TO-AIR FLUSH-MOUNT MODEL

Model	Weight	Rating @ 20°C ΔT BTU / hr	Amps Current Draw at 115 volts AC	Fan Size	Dimensions-Inches (H x W x D)
CC901F-WL-TYPE 4X	30 lbs	4,500	0.6	2 x 6"	15 x 13-7/8 x 7-7/8

Efficiency: 66.0 Watts / °C ΔT based on average internal cabinet temperature.

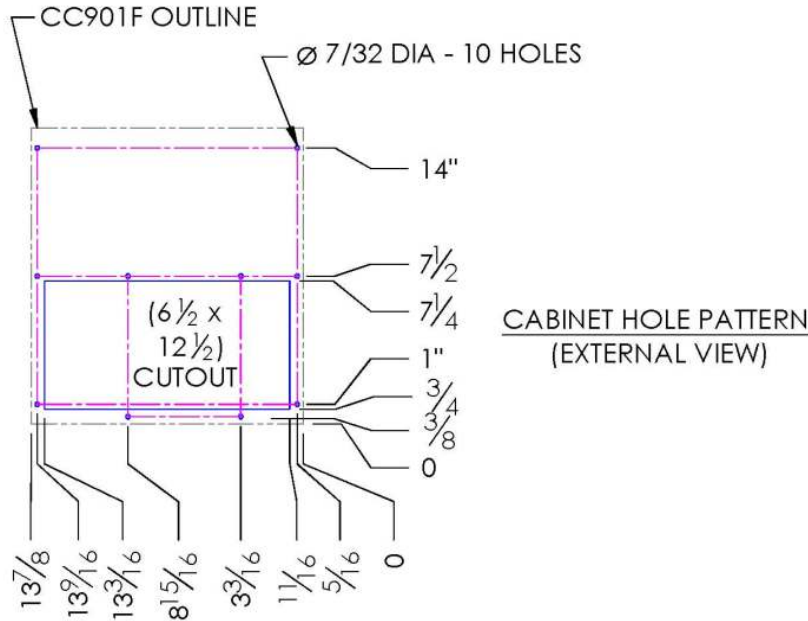
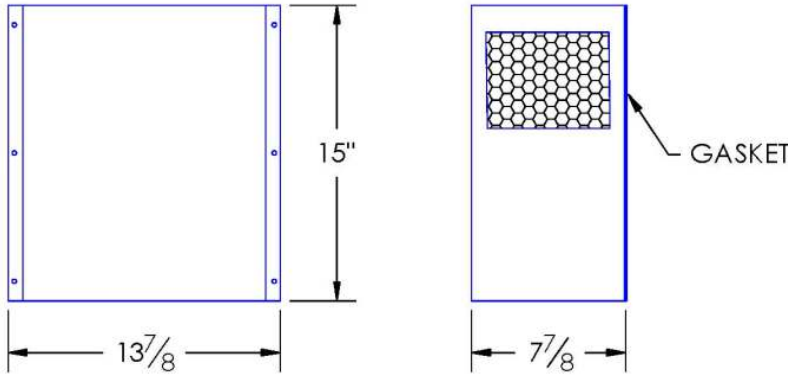

Outside View



Inside View

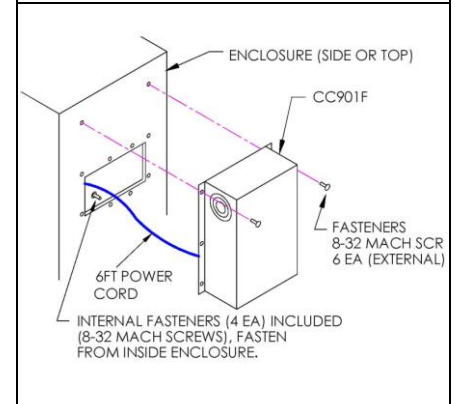

SPECIFICATIONS

1. UL Listed for TYPE 4 or 4X environments.
2. CC901F Rated cooling: 1,320 Watts at 20°C ΔT (66.0 W/°C, mounted to an uninsulated 72" x 36" x 24" cabinet.)
3. Designed for surface mounting on outside of cabinet.
4. Housing is Type 304 Stainless Steel. (316 SS or powder coated Aluminum optional.)
5. Equipped with mounting gasket to maintain the TYPE 4X integrity of your cabinet.
6. Pressure tested to insure liquid tight seal.
7. External fan is UL rated for Wet Locations / Outdoor use (WL).
8. Internal 6-ft. power cord with 3-prong plug is standard for AC powered units.
9. Available with VAC (115 & 230) and VDC (12, 24, & 48) fans. DC powered units include junction box, consult website.
10. Vertical mounting (as shown) is standard. Call for horizontal applications.
11. Optional: inlet air-filter kit available upon request.
12. For design, quote, and sizing assistance: call (650) 322-9500.

Subject to change without notice.



UL File #SA9567



Proudly made in USA



ISO 9001:2008
FM 554949

NOREN 1010 O'Brien Drive
Menlo Park, CA 94025
650.322.9500
norenproducts.com

CC901F-WL-TYPE 4X

CCS-PBD-7.2.2-883389-B