

# AN7125

## Dual Channel BTL Power Amplifier

### ■ Overview

AN7125 is a monolithic integrated circuit designed for 13.5 W (12 V, 4 Ω) output audio power amplifier. It is a dual channel BTL IC suitable for stereo operation in radio cassette and TV application.

### ■ Features

- Built-in muting pin
- Built-in stand by pin
- Built-in thermal shutdown protection circuit
- Built-in current limiting circuit
- High power : (13.5 W/12 V/4 Ω)  
(13.0 W/15 V/8 Ω)
- Few external components
- Operating voltage range 6 V ~ 18 V (12 V typ.)

### ■ Applications

- Radio-cassette

### ■ Block Diagram

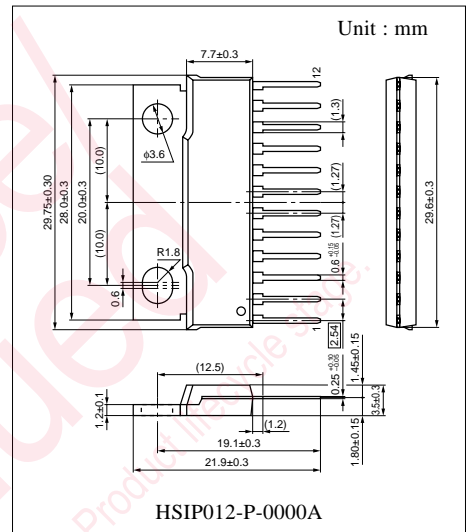
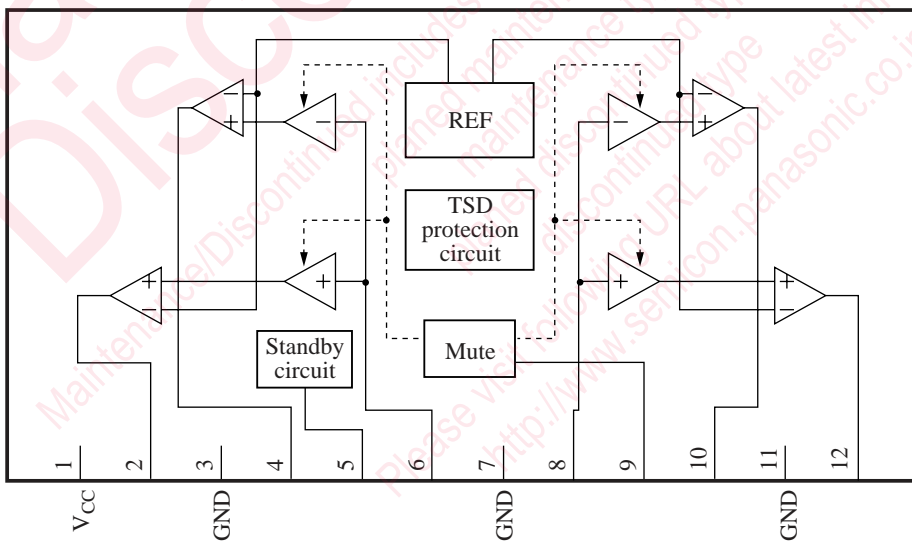

### ■ Pin Descriptions

| Pin No. | Description           | Pin No. | Description           |
|---------|-----------------------|---------|-----------------------|
| 1       | V <sub>CC</sub>       | 7       | Pre GND               |
| 2       | ch.1 +ve Phase Output | 8       | ch.2 Input            |
| 3       | ch.1 Output GND       | 9       | Mute                  |
| 4       | ch.1 -ve Phase Output | 10      | ch.2 -ve Phase Output |
| 5       | Standby               | 11      | ch.2 Output GND       |
| 6       | ch.1 Input            | 12      | ch.2 +ve Phase Output |

### ■ Absolute Maximum Ratings

| Parameter                     | Symbol           | Ratings     | Unit |
|-------------------------------|------------------|-------------|------|
| Supply voltage *1             | V <sub>CC</sub>  | 24          | V    |
| Supply current                | I <sub>CC</sub>  | 6.0         | A    |
| Power dissipation *2          | P <sub>D</sub>   | 38.5        | W    |
| Operating ambient temperature | T <sub>opr</sub> | -25 to +75  | °C   |
| Storage temperature           | T <sub>stg</sub> | -55 to +150 | °C   |

Note) \*1 : Without input signal, V<sub>CC</sub> is up to 24 V

\*2 : T<sub>a</sub> = 75 °C.

### ■ Recommended Operating Range

| Parameter      | Symbol          | Range       | Unit |
|----------------|-----------------|-------------|------|
| Supply voltage | V <sub>CC</sub> | 6.0 to 18.0 | V    |

### ■ Electrical Characteristics at V<sub>CC</sub> = 12 V, R<sub>L</sub> = 4 Ω, freq. = 1 kHz, 2 channel outputs, T<sub>a</sub> = 25 °C

| Parameter                    | Symbol           | Conditions   | Min  | Typ  | Max | Unit  |
|------------------------------|------------------|--|------|------|-----|-------|
| Quiescent circuit current    | I <sub>CQ</sub>  | V <sub>IN</sub> = 0 mV   | —    | 100  | 210 | mA    |
| Output noise voltage *1      | V <sub>NO</sub>  | V <sub>IN</sub> = 0 mV, R <sub>G</sub> = 6.2 kΩ  | —    | 0.27 | 0.5 | mVrms |
| Voltage gain                 | G <sub>VC</sub>  | V <sub>IN</sub> = 20 mV  | 38   | 40   | 42  | dB    |
| Total harmonic distortion *2 | THD              | V <sub>IN</sub> = 20 mV  | —    | 0.07 | 0.4 | %     |
| Maximum output power         | P <sub>O</sub>   | THD = 10 %   | 10   | 12   | —   | W     |
| Channel balance              | CB               | V <sub>IN</sub> = 20 mV  | -1   | 0    | 1   | dB    |
| Channel crosstalk *2         | CT               | V <sub>IN</sub> = 20 mV, R <sub>G</sub> = 6.2 kΩ                                       | 55   | 70   | —   | dB    |
| Output offset voltage        | V <sub>OFF</sub> | R <sub>G</sub> = 6.2 kΩ  | -350 | 0    | 350 | mV    |
| Ripple rejection *1          | RR               | V <sub>R</sub> = 1 V <sub>rms</sub> , f <sub>R</sub> = 120 Hz, R <sub>G</sub> = 6.2 kΩ | 50   | 60   | —   | dB    |
| Standby current              | I <sub>STB</sub> | V <sub>IN</sub> = 0 mV   | —    | 1    | 10  | μA    |
| Muting effects *2            | MT               | V <sub>IN</sub> = 20 mV  | 70   | 80   | —   | dB    |

Note) \*1 : With a filter band 20 Hz to 20 kHz (12 dB/OCT) used.

\*2 : With a filter band 400 Hz to 30 kHz used.

■ Terminal Equivalent Circuit

| Pin No. | Equivalent Circuit | Function   | Status                  |
|---------|--------------------|--|-------------------------|
| 1       | —                  | V <sub>CC</sub> :<br>V <sub>CC</sub> input   | typ. : 12 V             |
| 2       |                    | ch.1 O/P :<br>ch.1 positive phase output pin.  | V <sub>CC</sub> /2      |
| 3       |                    | ch.1 Power GND :<br>ch.1 output power ground pin.                                    | 0 V                     |
| 4       |                    | ch.1 O/P :<br>ch.1 inverse phase output pin.   | V <sub>CC</sub> /2      |
| 5       |                    | Standby :<br>This is the standby control pin.<br>STB off > 3.5 V<br>STB on = 0 V/GND | V <sub>TH</sub> = 2.8 V |
| 6       |                    | ch.1 Input :<br>This is the amplifier input pin.                                     | 0 V                     |
| 7       | —                  | Pre GND :<br>Input ground pin.   | 0 V                     |

■ Terminal Equivalent Circuit(continued)

| Pin No. | Equivalent Circuit | Function   | Status           |
|---------|--------------------|--|------------------|
| 8       |                    | ch.2 Input :<br>This is the amplifier input pin.               | 0 V              |
| 9       |                    | Mute :<br>Mute input pin.<br>Mute on > 2.5 V<br>Mute off = 0 V | $V_{TH} = 1.5 V$ |
| 10      |                    | ch.2 Output :<br>ch.2 inverse phase output pin                 | $V_{CC}/2$       |
| 11      |                    | ch.2 Power GND :<br>ch.2 output power ground                   | 0 V              |
| 12      |                    | ch.2 Output :<br>ch.2 positive phase output pin                | $V_{CC}/2$       |

### ■ Application Circuit Example

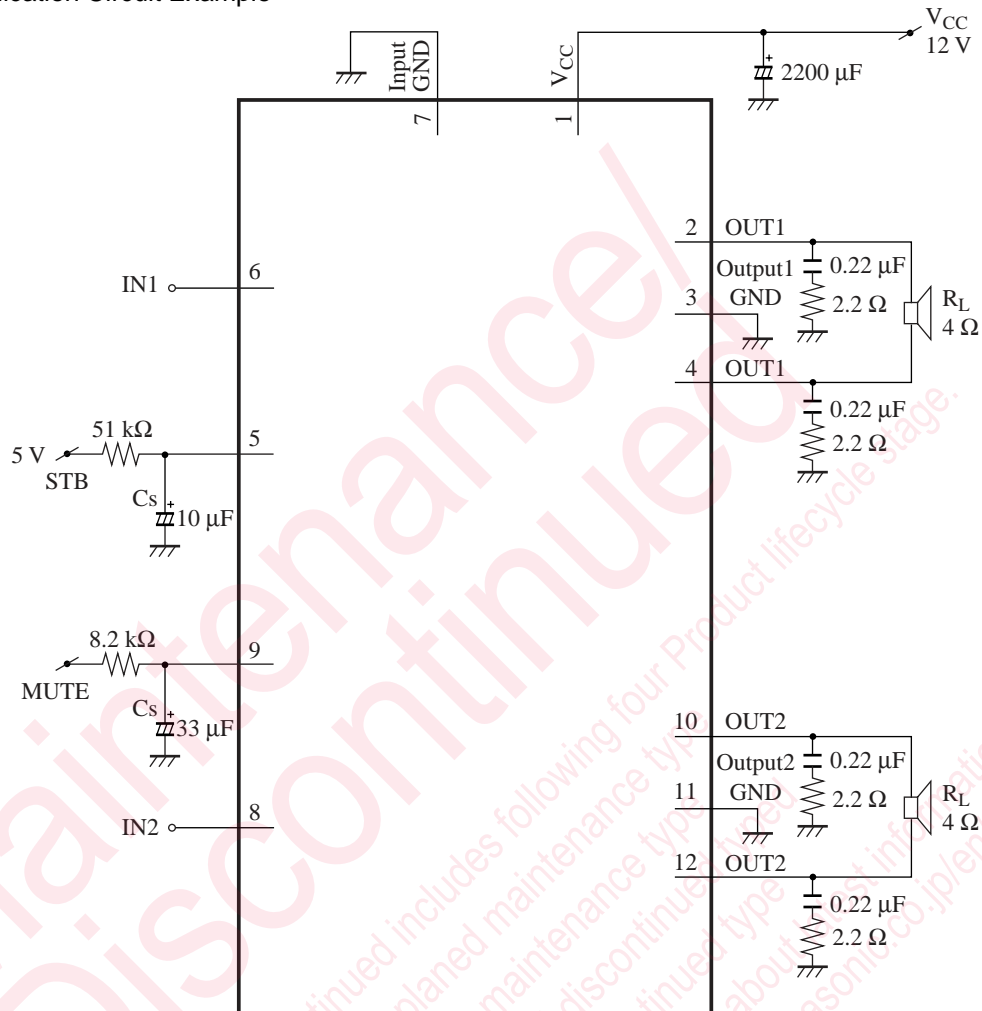

|            |     |
|------------|-----|
| STB 'Off'  | 5 V |
| STB 'On'   | 0 V |
| Mute 'Off' | 0 V |
| Mute 'On'  | 5 V |

### ■ Application's Precautions

1. External heatsink is needed when used. External heatsink should be fixed to the chassis.
2. Fin of the IC can be connected to GND.
3. Please prevent output to  $V_{CC}$  short and output to GND short.
4. The temperature protection circuit will operate at  $T_j$  around 150 °C.

However, if temperature decrease, the protection circuit will automatically be decreased and resume normal operation.

■ Technical Information

- HSIP012-P-0000A

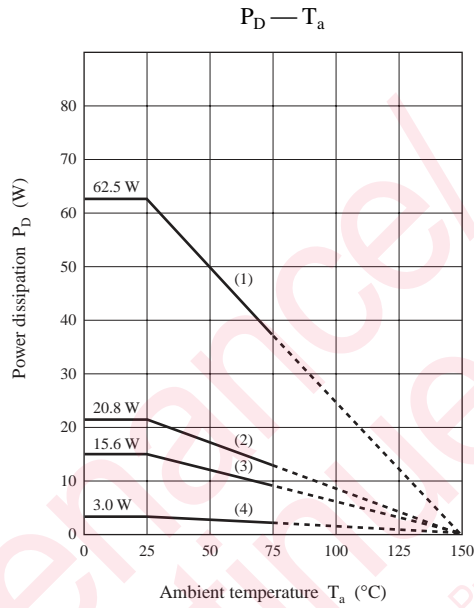

1.  $T_C = T_a$ , 62.5 W ( $\theta_{j-c} = 2^{\circ}\text{C/W}$ )
2. 20.83 W ( $\theta_f = 4.0^{\circ}\text{C/W}$ )  
With a 100 cm<sup>2</sup> X 3 mm Al heat sink (black colour coated) or a 200 cm<sup>2</sup> X 2 mm Al heat sink (not lacquered)
3. 15.63 W ( $\theta_f = 6.0^{\circ}\text{C/W}$ )  
With a 100 cm<sup>2</sup> X 2 mm Al heat sink (not lacquered)
4. 3.0 W at  $T_a = 25^{\circ}\text{C}$  ( $\theta_{j-a} = 42^{\circ}\text{C/W}$ )  
Without heat sink

- Area of safe operation

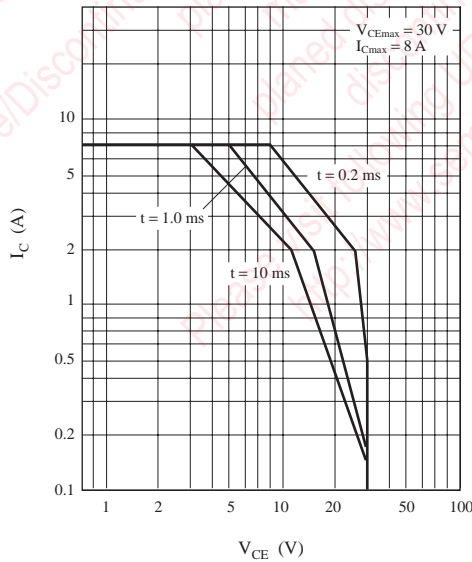

## Request for your special attention and precautions in using the technical information and semiconductors described in this book

- (1) If any of the products or technical information described in this book is to be exported or provided to non-residents, the laws and regulations of the exporting country, especially, those with regard to security export control, must be observed.
- (2) The technical information described in this book is intended only to show the main characteristics and application circuit examples of the products, and no license is granted under any intellectual property right or other right owned by our company or any other company. Therefore, no responsibility is assumed by our company as to the infringement upon any such right owned by any other company which may arise as a result of the use of technical information described in this book.
- (3) The products described in this book are intended to be used for standard applications or general electronic equipment (such as office equipment, communications equipment, measuring instruments and household appliances).  
Consult our sales staff in advance for information on the following applications:
  - Special applications (such as for airplanes, aerospace, automobiles, traffic control equipment, combustion equipment, life support systems and safety devices) in which exceptional quality and reliability are required, or if the failure or malfunction of the products may directly jeopardize life or harm the human body.
  - Any applications other than the standard applications intended.
- (4) The products and product specifications described in this book are subject to change without notice for modification and/or improvement. At the final stage of your design, purchasing, or use of the products, therefore, ask for the most up-to-date Product Standards in advance to make sure that the latest specifications satisfy your requirements.
- (5) When designing your equipment, comply with the range of absolute maximum rating and the guaranteed operating conditions (operating power supply voltage and operating environment etc.). Especially, please be careful not to exceed the range of absolute maximum rating on the transient state, such as power-on, power-off and mode-switching. Otherwise, we will not be liable for any defect which may arise later in your equipment.  
Even when the products are used within the guaranteed values, take into the consideration of incidence of break down and failure mode, possible to occur to semiconductor products. Measures on the systems such as redundant design, arresting the spread of fire or preventing glitch are recommended in order to prevent physical injury, fire, social damages, for example, by using the products.
- (6) Comply with the instructions for use in order to prevent breakdown and characteristics change due to external factors (ESD, EOS, thermal stress and mechanical stress) at the time of handling, mounting or at customer's process. When using products for which damp-proof packing is required, satisfy the conditions, such as shelf life and the elapsed time since first opening the packages.
- (7) This book may be not reprinted or reproduced whether wholly or partially, without the prior written permission of Matsushita Electric Industrial Co., Ltd.