

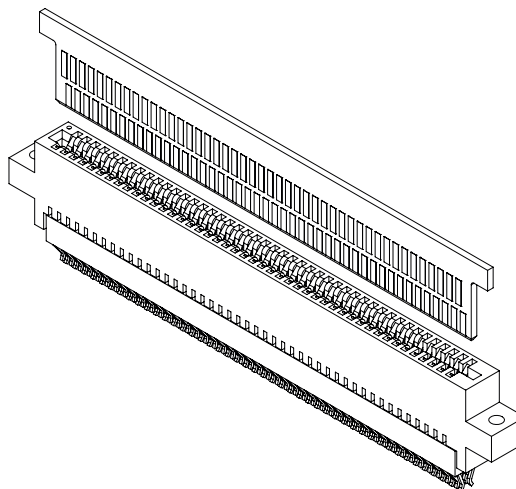

## Bi-Level High Density, .050" [1.27 mm] / .100" [2.54 mm] Contact Centers Card Extender, Dip Solder for .062" [1.57 mm] or .093" [2.36 mm] Mating PCB

### SPECIFICATIONS

- .050" [1.27 mm] Contact Center Spacing can replace .100" [2.54 mm] Contact Center part to double the number of contacts within the same area
- Backwards Compatible with Daughter Card Side
- Accommodates .062" ± .008" [1.57 mm ± 0.20 mm] or .093" ± .008" [2.36 mm ± 0.20 mm] mating PCB
- Contact Material: Beryllium Copper or Phosphor Bronze
- Body Material: PA9T
- UL Flammability Rating: 94V-0
- 3 Amps current rating for one contact energized
- High power-per-inch
- Operating Voltage: 225 VAC
- Consult Factory for PC board layouts/technical drawings



Bi-Level Card Edge

### DIMENSIONS Dimensions in [ ] are in millimeters, all others are in inches.

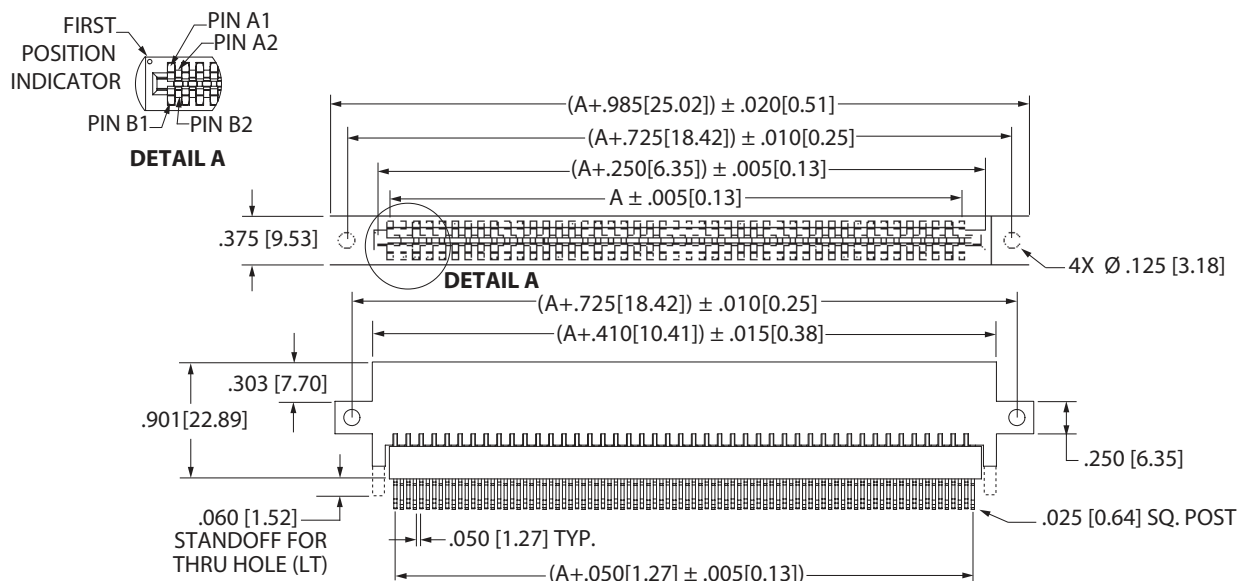

### DAUGHTER CARD LAYOUT

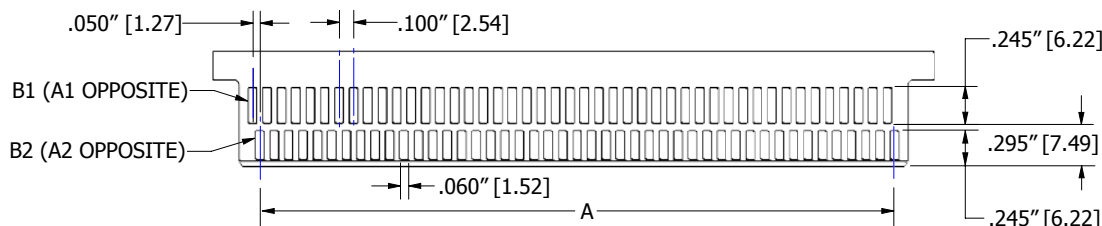



### Bi-Level High Density, .050" [1.27 mm] / .100" [2.54 mm] Contact Centers Card Extender, Dip Solder for .062" [1.57 mm] or .093" [2.36 mm] Mating PCB

Bi-Level Card Edge

#### PART NUMBER OPTIONS

J C B 10 D LT H - Sxxxx

#### MATERIALS (INSULATOR/CONTACT)

- G = PA9T/Phosphor Bronze
- J = PA9T/Beryllium Copper

Refer to Page 7 for Operating/Processing Temperatures

#### CONTACT FINISH - RoHS Compliant

All platings are Lead Free and have .000050" Nickel underplate

#### Contact Surface Termination

- B = .000010" Gold .000100" Pure Tin, Matte
- C = .000030" Gold .000100" Pure Tin, Matte
- Y = .000030" Gold .000005" Gold

#### CONTACT CENTERS

- B = .050" [1.27 mm] / .100" [2.54 mm]

**MODIFICATION CODE** (Consult Factory)  
OMIT FOR STANDARD

- S1176 = For .093" ± .008" [2.36 ± 0.20]  
Thick Mating PCB

POSITIONS	DIMENSION A (See Opposite Page)		
	No. of Contacts	in	mm
06	12	0.200	5.08
08*	16	0.300	7.62
10	20	0.400	10.16
12	24	0.500	12.70
14*	28	0.600	15.24
16*	32	0.700	17.78
18*	36	0.800	20.32
20	40	0.900	22.86
22*	44	1.000	25.40
24	48	1.100	27.94
26*	52	1.200	30.48
28*	56	1.300	33.02
30	60	1.400	35.56
32*	64	1.500	38.10
34	68	1.600	40.64
36	72	1.700	43.18
38*	76	1.800	45.72
40	80	1.900	48.26
42	84	2.000	50.80
44	88	2.100	53.34
46*	92	2.200	55.88
48*	96	2.300	58.42
50	100	2.400	60.96
52	104	2.500	63.50
54*	108	2.600	66.04
56	112	2.700	68.58
58*	116	2.800	71.12
60	120	2.900	73.66
62*	124	3.000	76.20
64*	128	3.100	78.74
66*	132	3.200	81.28
68*	136	3.300	83.82
70	140	3.400	86.36
72	144	3.500	88.90
74*	148	3.600	91.44
76	152	3.700	93.98
78	156	3.800	96.52
80	160	3.900	99.06
82*	164	4.000	101.60
84*	168	4.100	104.14
86	172	4.200	106.68
88*	176	4.300	109.22
90	180	4.400	111.76
100	200	4.900	124.46
120†	240	5.900	149.86

#### MOUNTING STYLE

H	MOUNTING HOLES	
S	SIDE MOUNTING HOLES	
I	#4-40 THREADED INSERTS	
A	#4-40 THREADED INSERTS IN SIDE HOLES	
N	NO MOUNTING EARS	
W	FLUSH MOUNTING (LT TERMINATION ONLY)	

#### TERMINATION

##### DIP SOLDER LT

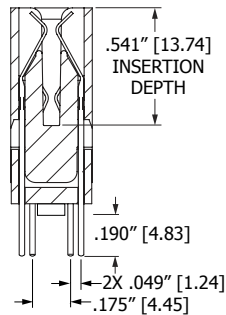

##### CARD EXTENDER LR

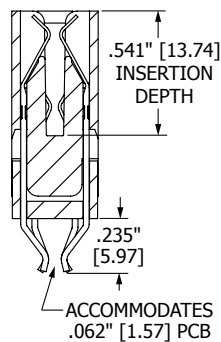

\* Consult factory for availability. † Available in 'N' mounting only.