

REVISIONS					
REV	ECO	DESCRIPTION	DATE	BY	APPR
B1	-	RELEASE NEW DWG FORMAT	06/16/14	TOD	TOMMY

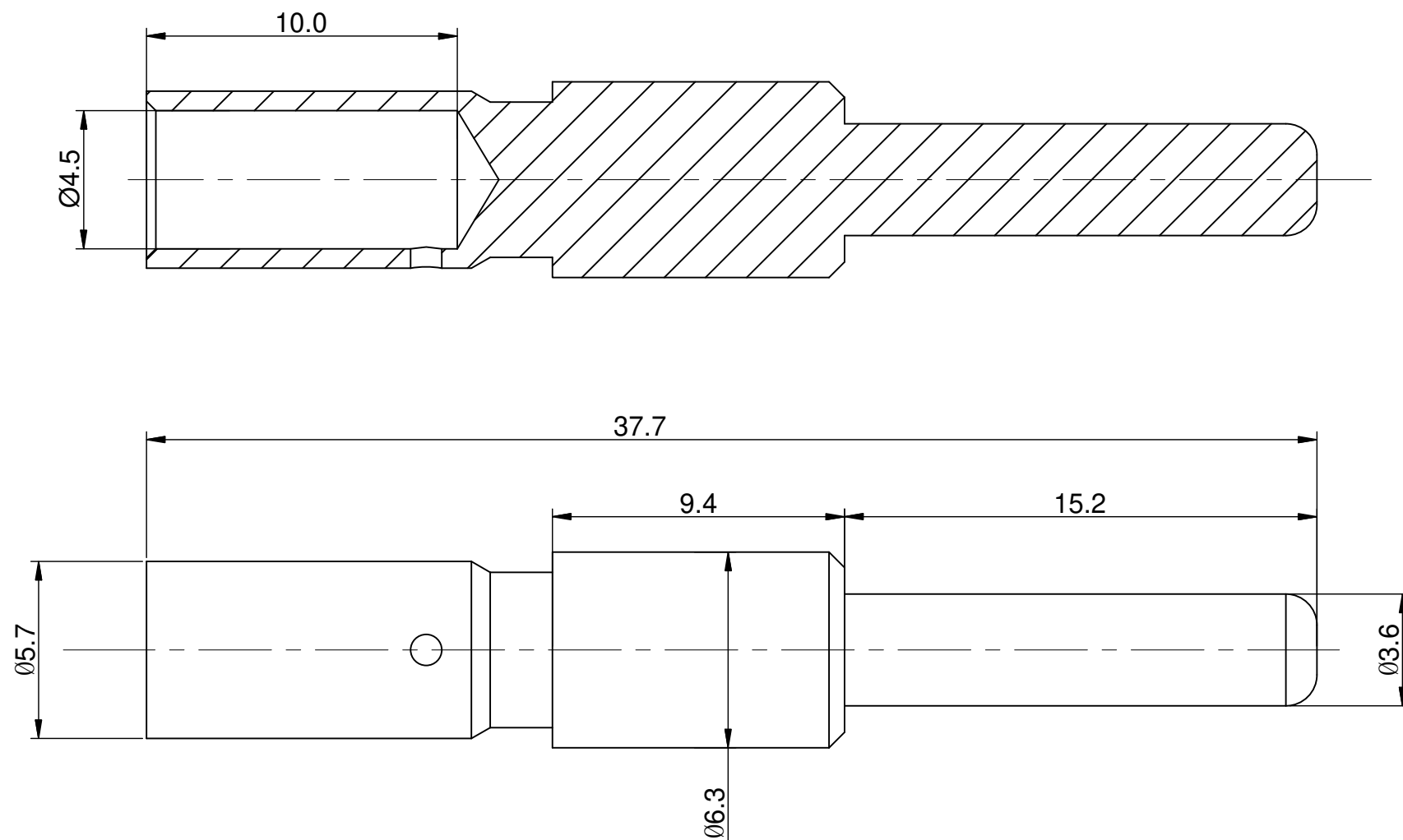

NOTES: UNLESS OTHERWISE SPECIFIED

- MATERIAL: COPPER ALLOY, GOLD PLATED
- SPECIFICATIONS:
  - RATED CURRENT: 75 AMPS
  - CONTACT RESISTANCE: <1 milliohm
  - AVAILABLE WIRE RANGE: 12AWG~8AWG
  - RoHS COMPLIANT
- ALL DIMENSIONS ARE FOR REFERENCE USE ONLY.



TITLE: Pin contact,8#,Crimp 12-8AWG  
 DWG NO: SC000041  
 REV: B1  
 SH: 1  
 OF: 1

QUANTITY	SEE PART NUMBER CHART PART NUMBER	DESCRIPTION	ITEM
<b>MATERIALS LIST</b>			
UNLESS OTHERWISE SPECIFIED 1) All dimensions are in metric(mm). 2) Tolerances are as follows: 1 PL DEC $\pm 0.30$ 2 PL DEC $\pm 0.15$ 3 PL DEC $\pm 0.08$ Fractions $\pm 1/64$ Angles $\pm 1^\circ$ 3) Note reference = $\triangle X$		SIGNATURES DRAWN: Tod CHECKED: ENGINEER: APPROVAL: CUSTOMER:	DATE 06/16/14
MATERIAL SPECIFICATIONS:		<b>Amphenol</b> Sine Systems - www.amphenol-sine.com 44724 Morley Drive Clinton Township, MI 48036	
PROCESS SPECIFICATIONS:		Pin contact,8#,Crimp 12~8AWG	
NEXT ASSY:		THIS DRAWING IS SUPPLIED FOR INFORMATION ONLY. DESIGN FEATURES, SPECIFICATIONS AND PERFORMANCE DATA SHOWN HEREON ARE THE PROPERTY OF THE AMPHENOL CORPORATION. NO RIGHTS OF REPRODUCTION ARE IMPLIED. ALL DIMENSIONS ARE SUBJECT TO NORMAL MANUFACTURING VARIATIONS.	SIZE: <b>B</b> TYPE: <b>C-</b> SCALE: NONE
		DWG NO: <b>SC000041</b>	REVISION: <b>B1</b>
		SHEET 1 OF 1	