

PROPER USE GUIDELINES

Cumulative Trauma Disorders can result from the prolonged use of manually powered hand tools. Hand tools are intended for occasional use and low volume applications. A wide selection of powered application equipment for extended-use, production operations is available.

SDE PEW-12 Hand
Crimping Tool 2031734-1

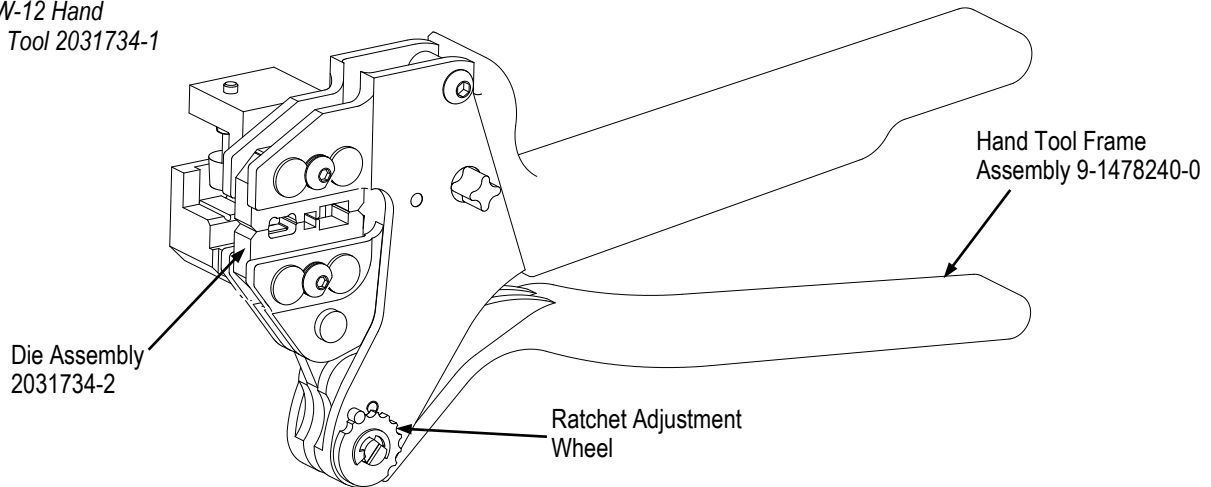

Figure 1

1. INTRODUCTION

This instruction sheet provides information on the application and maintenance procedures for the SDE PEW-12 Hand Crimping Tool 2031734-1. This tool consists of Hand Tool Frame Assembly 9-1478240-0 (Instruction Sheet [408-8851](#)), and die assembly 2031734-2. See Figure 1.



NOTE

Dimensions in this instruction sheet are in millimeters with [inches in brackets]. Figures and illustrations are for reference only and are not drawn to scale.

2. DESCRIPTION

The die assembly is designed with two crimp nests to terminate the RJ Point Five* Plug Kit 2007312-1 utilizing a shell crimp (scroll crimp), and a contact piercing crimp. This document only deals with the termination procedures. Complete assembly procedures for the plug kit may be found in Application Specification [114-13235](#).

3. INSTALLATION AND REMOVAL OF DIE SET AND LOCATOR ASSEMBLY

1. Open the tool handles and remove the two die retaining screws from the tool jaws.
2. Place the wire anvil so that the chamfered side and the marked surfaces face outward, when mounted in the moving jaw of the tool frame.
3. Insert the short die retaining screw through the jaw and through the anvil die, and tighten the screw just enough to hold the die in place. Do not tighten the screw completely at this time.
4. Place the wire crimper so that the chamfered side and the marked surface face outward, when mounted in the stationary jaw of the tool frame.
5. Insert the long die retaining screw through the jaw and through the crimper die, and tighten the screw just enough to hold the die in place. Do not tighten the screw completely at this time.
6. Carefully close the tool handles, making sure that the anvil and crimper align properly. Continue closing the tool handles until the ratchet in the tool frame has engaged sufficiently to hold the anvil and crimper in place, then tighten both die retaining screws.

7. Place the nut onto the end of the long screw and tighten the nut enough to hold the locator assembly in place, while still allowing the locator to slide up and down.
8. To disassemble, close the tool handles until the ratchet releases, remove the nut, the locator assembly, the two die retaining screws, and slide the anvil and crimper out of the tool jaws.



NOTE

The ratchet has detents with audible “clicks” as the handles are closed. The ratchet releases on the sixth “click”.

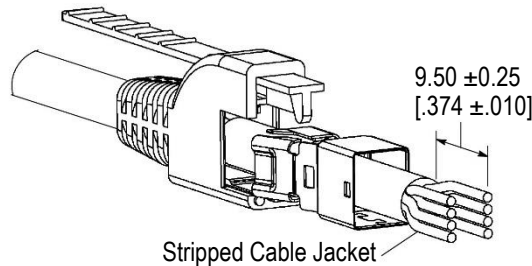

Figure 2

4. CRIMPING PROCEDURES



NOTE

Prior to stripping the cable, make sure to slide the strain relief and shell onto the cable and away from the stripping area. See Figure 2.



NOTE

This tool is provided with a crimp adjustment feature. Initially, the crimp height should be verified as specified in Figure 7. Refer to Section 5, Crimp Height Inspection, and Section 6, crimp height Adjustment, to verify crimp height before using the tool to crimp desired contacts and wire sizes.

1. Strip the cable jacket to 9.50 ± 0.25 mm [0.374 ± 0.010 in.] as shown in Figure 2.
2. Insert the discrete wires into the wire holders according to the wiring diagram provided in Figure 3 until bottomed. After wire insertion, the holders shall be sandwiched on the plug body prior to crimping. See Figure 3.

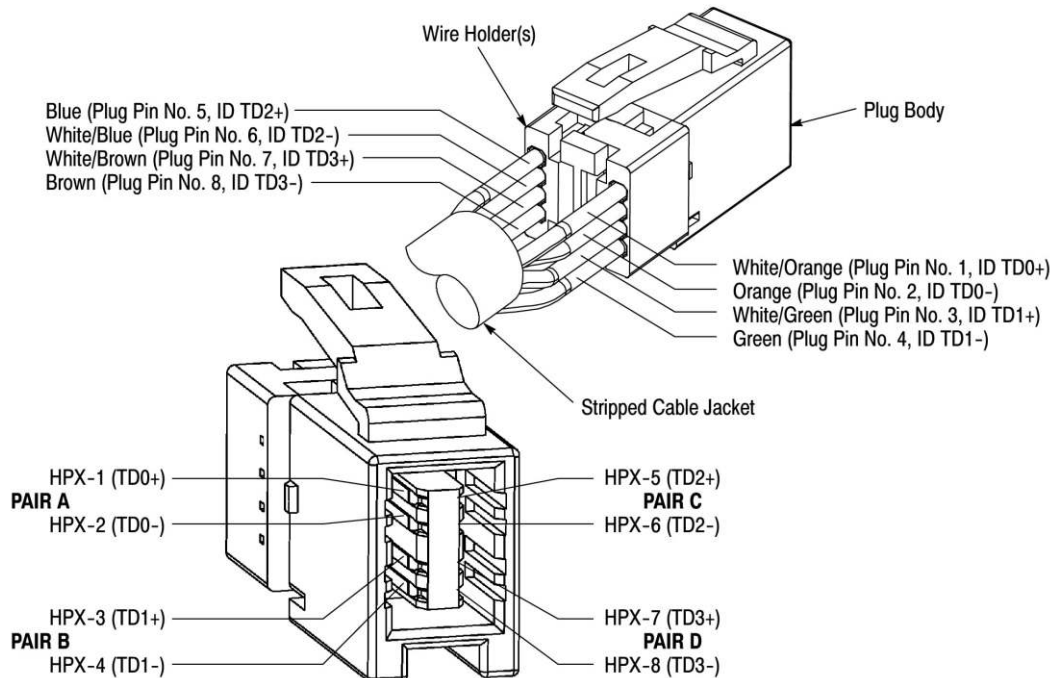

Figure 3

3. Hold the tool so that the back (wire side) is facing you. Squeeze tool handles together and allow them to open fully.

i **NOTE**
Make sure the wires are bottomed in their respective wire slots prior to the crimping procedure.

4. Insert the assembly into the lower jaw of the hand tool. Locate the module and crimp. See Figure 4.

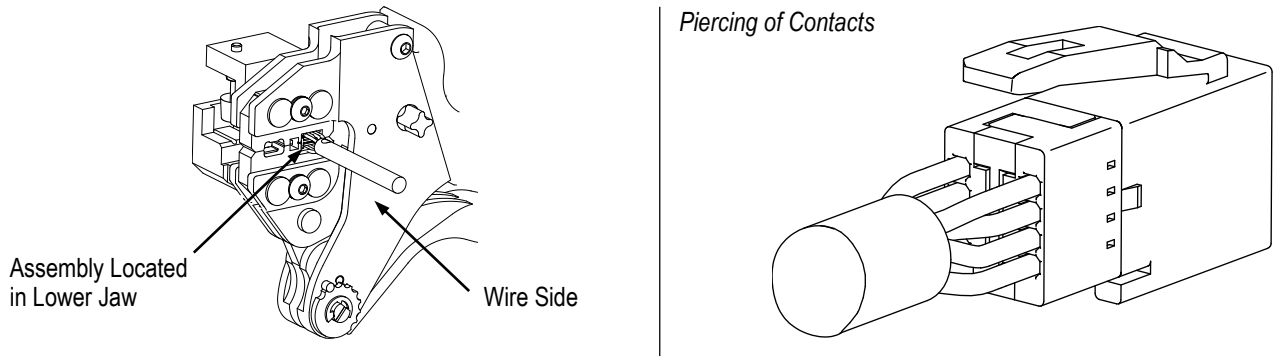

Figure 4

5. After termination, slide the shell over the module assembly and bottom. In order to ensure that the shell is oriented properly for placement in the crimping tool, make sure the shell seam is opposite the plug latch prior to insertion of the plug body. See Figure 5.

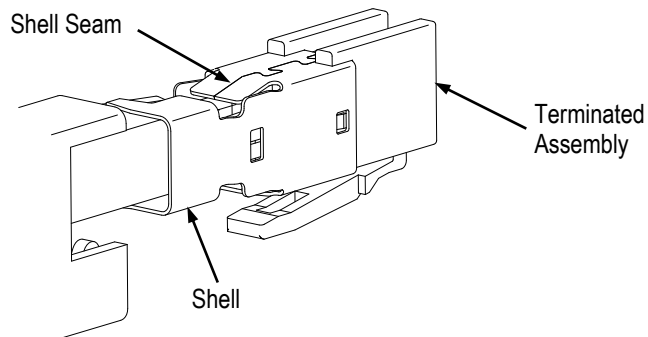

Figure 5

6. Insert assembly into the jaw of the hand tool and crimp.

i **NOTE**
Make sure the cable jacket is located under the crimp area of the shell. See Figure 6.

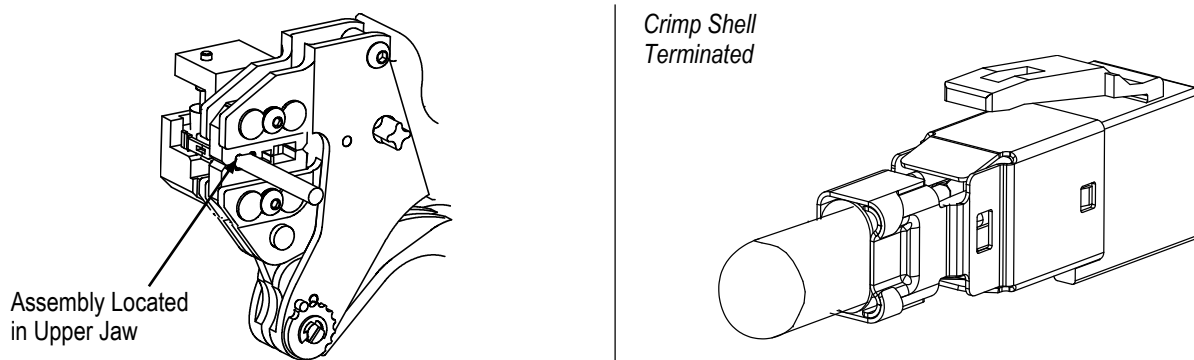

Figure 6

- Complete the assembly procedures according to the information provided in Application Specification 114-13235.

5. CRIMP HEIGHT INSPECTION

Proceed as follows:

- Refer to Section 4, CRIMPING PROCEDURE, and crimp the contact(s) accordingly.
- Measure the wire barrel crimp height listed in Figure 7. If the crimp height conforms to that shown in the table, the tool is considered dimensionally correct. If not, the tool must be adjusted. Refer to Section 6, CRIMP HEIGHT ADJUSTMENT.

| WIRE SIZE | CRIMP HEIGHT DIMENSION | |
|--------------|-------------------------|------------------------|
| | WIRE PIERCING | SCROLL CRIMP |
| See Figure 3 | 5.80 ±0.10 [.228 ±.004] | 4.75 ±0.13 [.187±.005] |

Figure 7



CAUTION

Damaged product should not be used. If a damaged contact is evident, it should be replaced. Contacts must not be re-terminated.

6. CRIMP HEIGHT ADJUSTMENT

Although the ratchet is preset prior to shipment, it is important to verify the crimp height using a micrometer or caliper. General use and subsequent wear may cause the tool to go out of adjustment. It is recommended that crimp height be inspected, and the ratchet be adjusted, if necessary, on a regular basis. Refer to Figure 8, and proceed as follows:

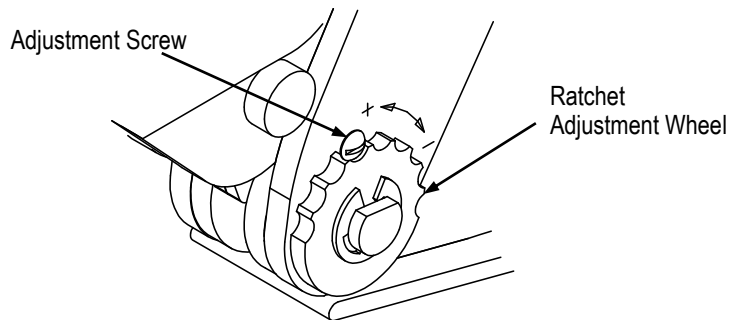

Figure 8

- If the crimp height is larger than recommended, remove the ratchet wheel adjustment screw and rotate the adjustment wheel counterclockwise (+) to a higher setting. Reinstall the screw. Repeat as required.
- If the crimp height is smaller than recommended, remove the ratchet wheel adjustment screw and rotate the adjustment wheel clockwise (-) to a lower setting. Reinstall the screw. Repeat as required.
- If the crimp cannot be made to conform to the recommended crimp height, the tool or die set must be replaced. See Section 9, REPLACEMENT.

7. MAINTENANCE AND INSPECTION

7.1. Daily Maintenance

- Remove dust, moisture, and other contaminants with a clean, soft brush, or a clean, soft, lint-free cloth. DO NOT use any objects that could damage the dies or tool.
- Make sure that the proper die retaining screws are properly secured.

3. When the tool is not in use, keep the handles closed to prevent objects from becoming lodged in the dies. Store the tool in a clean, dry area.
4. Remove all lubrication and accumulated film from the dies by immersing the dies in a suitable commercial degreaser.

7.2. Inspection

Close the tool handles until the ratchet releases, and then allow them to quickly open freely. If they do not open quickly and fully, the spring is defective. See Section 9, REPLACEMENT.

8. REPLACEMENT

Order replacements through your TE Connectivity Representative, or call 1-800-526-5142, or send a facsimile of your purchase order to 717-986-7605, or write to:

CUSTOMER SERVICE (038-035)
TYCO ELECTRONICS CORPORATION
PO BOX 3608
HARRISBURG PA 17105-3608

9. REVISION SUMMARY

- Updated document to corporate requirements
- Changed dimension in table in Figure 7