

VIEW W

- 1 00779 M39012/27B0016 AMP 225551-1 YY WW
- 2 00779 M39012/27B0005 AMP 225551-2 YY WW
- 3. SEE I.S. 2299-2

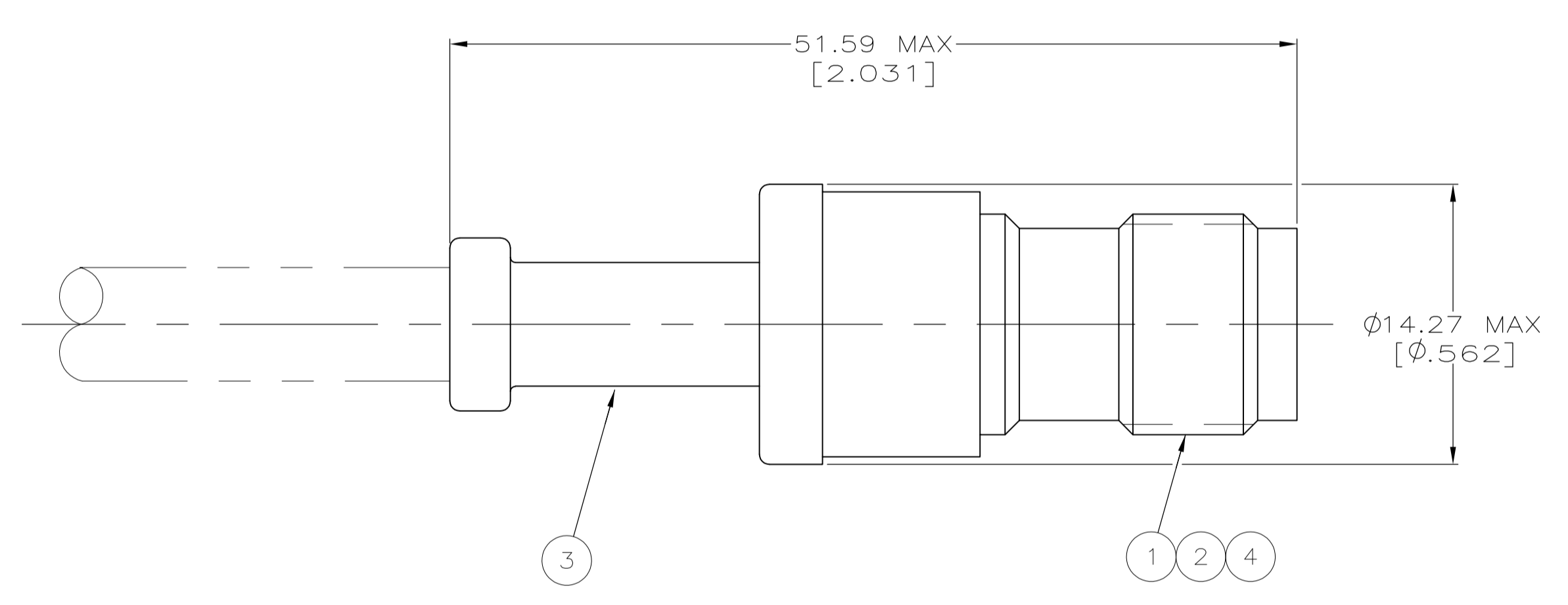

VIEW X

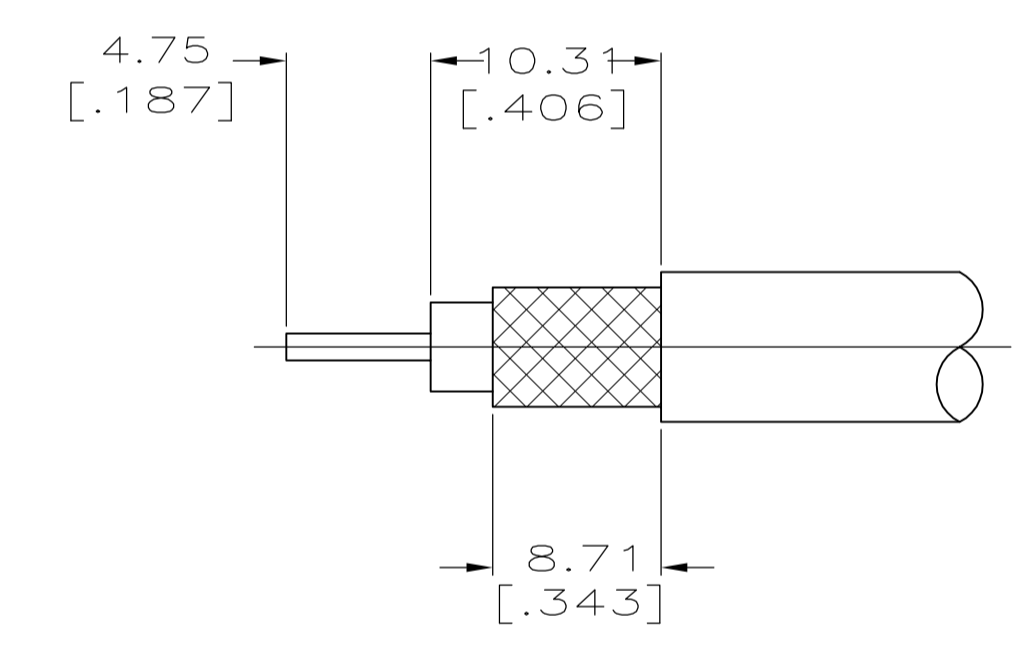

VIEW Y

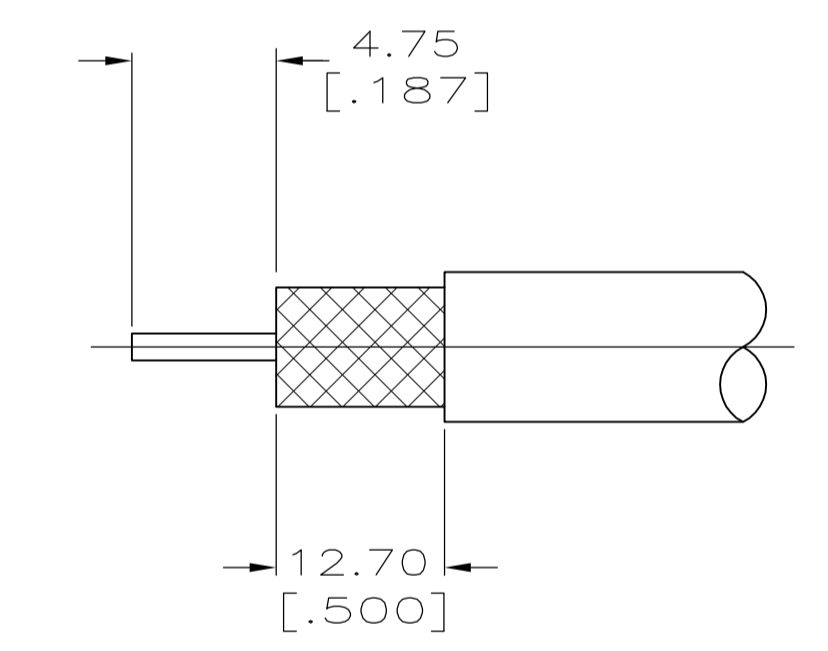

VIEW Z

RECOMMENDED STRIP LENGTH

RG-142/U,142A/U & 142B/U	7-225551-6 AMP	220045-2	W & Y	225592-2	225560-1	225471-3	225468-1	7-225551-6
RG-59B/U & 62B/U	7-225551-3 AMP	220045-3	W & Y	225592-3	225560-3	225471-2	225468-3	7-225551-3
RG-58A/U,58C/U & BSX 7002-58C/U	7-225551-2 AMP	220045-2	W & Y	225592-1	225560-2	225471-1	225468-1	7-225551-2
OBSOLETE RG-225/U	1-225551-2 AMP	220015-1	X & Z	332022	331987	225471-7	225597-2	1-225551-2
RG-142/U,142A/U & 142B/U	00779 M39012/27B0006 AMP YY WW	220045-2	W & Y	-	9-225560-4	1-225471-1	3-225468-1	225551-6
RG-141/U & 141A/U	00779 M39012/27B0015 AMP YY WW	220045-2	W & Y	225592-1	9-225560-5	1-225471-1	225468-1	225551-5
RG-58A/U,58C/U & BSX 7002-58C/U	1	220045-2	W & Y	-	9-225560-5	225471-9	2-225468-1	225551-2
RG-55A/U & 223/U	2	220045-2	W & Y	225592-2	9-225560-4	225471-9	225468-1	225551-1
CABLE SIZE	STAMPING	CRIMP TOOL	VIEW	4 GASKET QTY=1	3 FERRULE QTY=1	2 CONTACT QTY=1	1 JACK ASSY QTY=1	PART NUMBER

THIS DRAWING IS A CONTROLLED DOCUMENT.

DIMENSIONS: INCHES	TOLERANCES UNLESS OTHERWISE SPECIFIED:	DIN 3-6-91	APVD
0 PLC ± -	1 PLC ± -	3-11-91	J. LIPPERT
2 PLC ± 0.41 [016]	3 PLC ± -	NAME: JACK, WEATHERPROOF, SERIES, TNC	
4 PLC ± -	ANGLES ± -	PRODUCT SPEC: 108-12001	
MATERIAL	FINISH	SIZE: A1	WEIGHT: -
		SCALE: 4:1	SHEET 1 OF 1

CUSTOMER DRAWING