

# CAT4139

## White LED Driver, 22 V, High Current Boost

### Description

The CAT4139 is a DC/DC step-up converter that delivers an accurate constant current ideal for driving LEDs. Operation at a fixed switching frequency of 1 MHz allows the device to be used with small value external ceramic capacitors and inductor. LEDs connected in series are driven with a regulated current set by the external resistor R1. The CAT4139 is ideal for driving parallel strings of up to five white LEDs in series or up to 22 V.

LED dimming can be done by using a DC voltage, a logic signal, or a pulse width modulation (PWM) signal. The shutdown input pin allows the device to be placed in power-down mode with “zero” quiescent current.

In addition to thermal protection and overload current limiting, the device also enters a very low power operating mode during “Open LED” fault conditions. The device is housed in a low profile (1 mm max height) 5-lead TSOT-23 package for space critical applications.

### Features

- Switch Current Limit 750 mA
- Drives LED Strings up to 22 V
- Up to 87% Efficiency
- Low Quiescent Ground Current 0.6 mA
- 1 MHz Fixed Frequency Low Noise Operation
- Soft Start “In-rush” Current Limiting
- Shutdown Current Less than 1  $\mu$ A
- Open LED Overvoltage Protection
- Automatic Shutdown at 1.9 V (UVLO)
- Thermal Overload Protection
- TSOT-23 5-Lead (1 mm Max Height)
- These Devices are Pb-Free, Halogen Free/BFR Free and are RoHS Compliant

### Applications

- GPS Navigation Systems
- Portable Media Players
- Handheld Devices



ON Semiconductor®

[www.onsemi.com](http://www.onsemi.com)

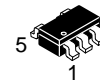

TSOT-23  
TD SUFFIX  
CASE 419AE

### PIN CONNECTIONS

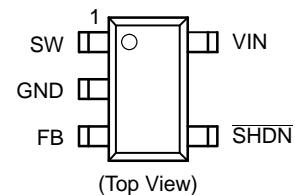

### MARKING DIAGRAM

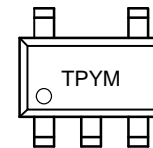

TP = Specific Device Code  
Y = Production Year (Last Digit)  
M = Production Month  
(1-9 (Jan-Sep), O, N, D (Oct-Dec))

### ORDERING INFORMATION

Device	Package	Shipping
CAT4139TD-GT3 (Note 1)	TSOT-23 (Pb-Free)	3,000/ Tape & Reel

1. NiPdAu Plated Finish (RoHS-compliant)

# CAT4139

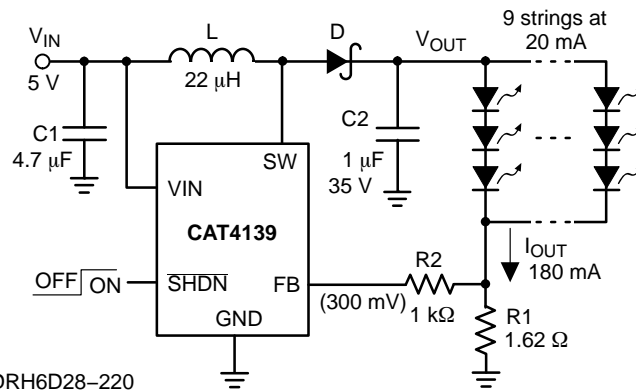

L: Sumida CDRH6D28–220  
D: Central CMSH1–40 (rated 40 V)

Figure 1. Typical Application Circuit

Table 1. ABSOLUTE MAXIMUM RATINGS

Parameters	Ratings	Units
VIN, FB Voltage	-0.3 to +7	V
SHDN Voltage	-0.3 to +7	V
SW Voltage	-0.3 to +40	V
Storage Temperature Range	-65 to +160	°C
Junction Temperature Range	-40 to +150	°C
Lead Temperature	300	°C

Stresses exceeding those listed in the Maximum Ratings table may damage the device. If any of these limits are exceeded, device functionality should not be assumed, damage may occur and reliability may be affected.

Table 2. RECOMMENDED OPERATING CONDITIONS (Typical application circuit with external components is shown above.)

Parameters	Range	Units
VIN	up to 5.5	V
SW pin voltage	0 to 22	V
Ambient Temperature Range (Note 2)	-40 to +85	°C

Functional operation above the stresses listed in the Recommended Operating Ranges is not implied. Extended exposure to stresses beyond the Recommended Operating Ranges limits may affect device reliability.

2. TSOT23–5 package thermal resistance  $\theta_{JA} = 135^{\circ}\text{C}/\text{W}$  when mounted on board over a ground plane.

# CAT4139

**Table 3. DC ELECTRICAL CHARACTERISTICS**

( $V_{IN} = 3.6\text{ V}$ , ambient temperature of  $25^{\circ}\text{C}$  (over recommended operating conditions unless otherwise specified))

Symbol	Parameter	Test Conditions	Min	Typ	Max	Units
$I_Q$	Operating Current	$V_{FB} = 0.2\text{ V}$ $V_{FB} = 0.4\text{ V}$ (not switching)		0.6 0.1	1.5 0.6	mA
$I_{SD}$	Shutdown Current	$\sqrt{SHDN} = 0\text{ V}$		0.1	1	$\mu\text{A}$
$V_{FB}$	FB Pin Voltage	9 x 3 LEDs, $I_{OUT} = 180\text{ mA}$	285	300	315	mV
$I_{FB}$	FB pin input leakage				1	$\mu\text{A}$
$I_{LED}$	Programmed LED Current	$R1 = 10\ \Omega$ $R1 = 3\ \Omega$	28.5	30 100	31.5	mA
$V_{IH}$ $V_{IL}$	SHDN Logic High SHDN Logic Low	Enable Threshold Level Shutdown Threshold Level	0.4	0.8 0.7	1.5	V
$F_{SW}$	Switching Frequency		0.8	1.0	1.3	MHz
$I_{LIM}$	Switch Current Limit	$V_{IN} = 3.6\text{ V}$ $V_{IN} = 5\text{ V}$	600 750			mA
$R_{SW}$	Switch "On" Resistance	$I_{SW} = 100\text{ mA}$		1.0	2.0	$\Omega$
$I_{LEAK}$	Switch Leakage Current	Switch Off, $V_{SW} = 5\text{ V}$		1	5	$\mu\text{A}$
$T_{SD}$	Thermal Shutdown			150		$^{\circ}\text{C}$
$T_{HYST}$	Thermal Hysteresis			20		$^{\circ}\text{C}$
$V_{UVLO}$	Under-voltage lock out (UVLO) Threshold			1.9		V
$V_{OV-DET}$	Over-voltage detection threshold		23	24		V
$V_{OCL}$	Output Clamp voltage	"Open LED"		29		V
DC	Maximum duty cycle Minimum duty cycle			92 16		%

Product parametric performance is indicated in the Electrical Characteristics for the listed test conditions, unless otherwise noted. Product performance may not be indicated by the Electrical Characteristics if operated under different conditions.

TYPICAL CHARACTERISTICS

( $V_{IN} = 5.0\text{ V}$ ,  $I_{OUT} = 180\text{ mA}$ ,  $T_{AMB} = 25^\circ\text{C}$ , with typical application circuit unless otherwise specified.)

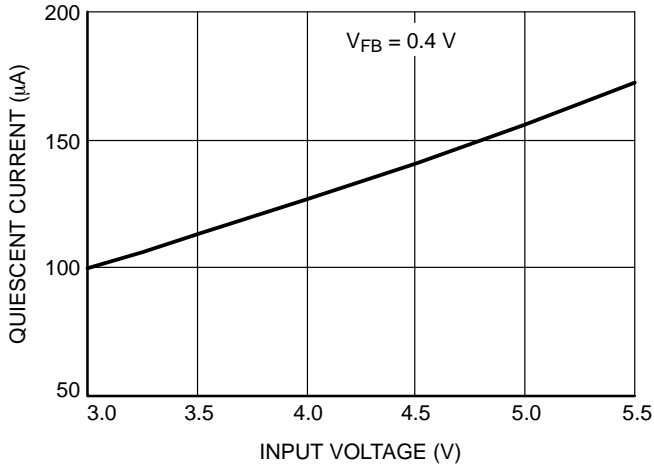

Figure 2. Quiescent Current vs.  $V_{IN}$  (Not Switching)

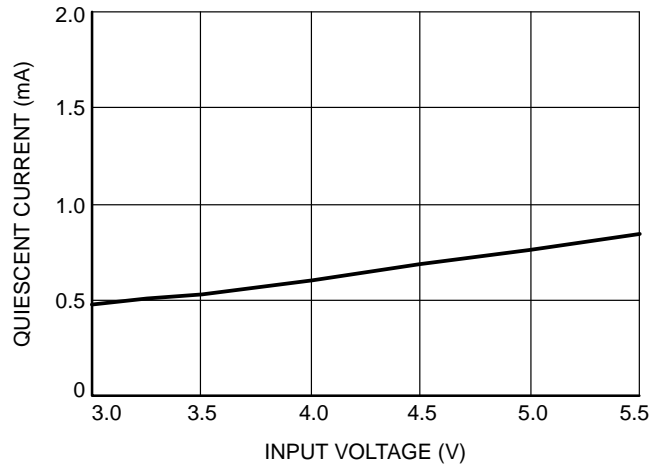

Figure 3. Quiescent Current vs.  $V_{IN}$  (Switching)

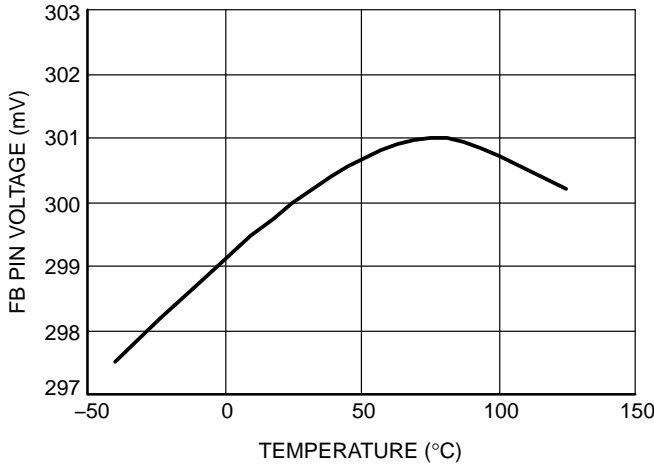

Figure 4. FB Pin Voltage vs. Temperature

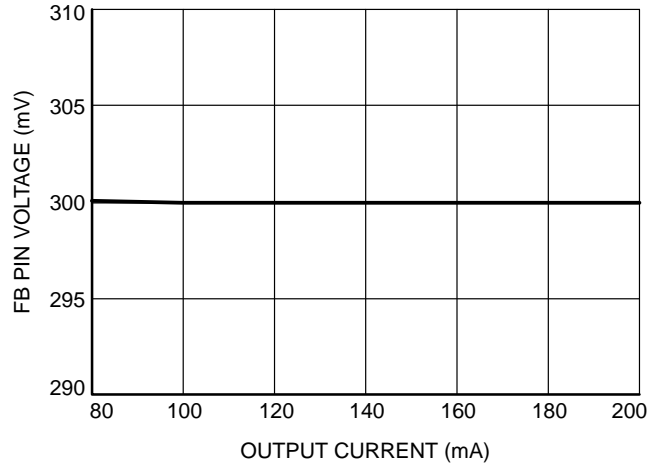

Figure 5. FB Pin Voltage vs. Output Current

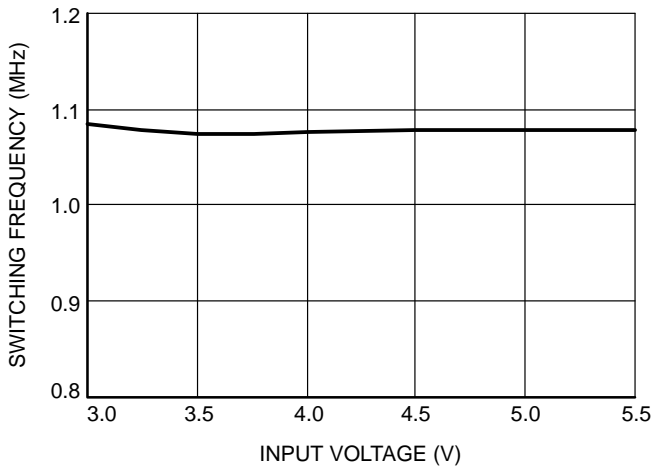

Figure 6. Switching Frequency vs. Supply Voltage

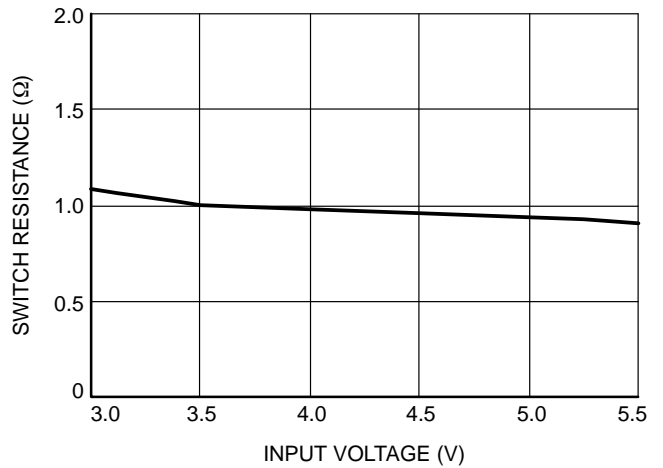

Figure 7. Switch ON Resistance vs. Input Voltage

# CAT4139

## TYPICAL CHARACTERISTICS

( $V_{IN} = 5.0\text{ V}$ ,  $I_{OUT} = 180\text{ mA}$ ,  $T_{AMB} = 25^\circ\text{C}$ , with typical application circuit unless otherwise specified.)

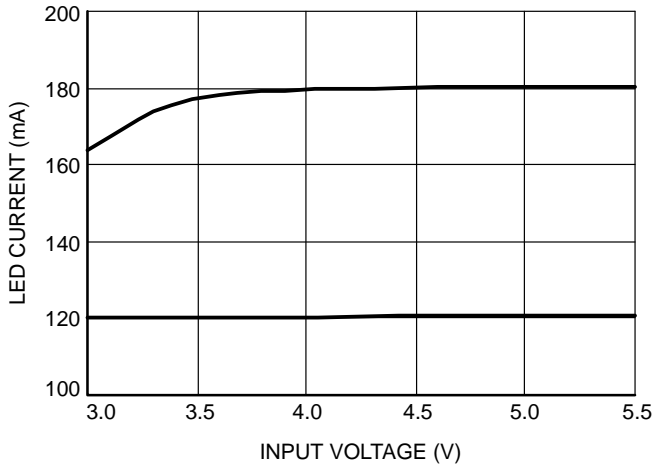

Figure 8. Output Current vs. Input Voltage

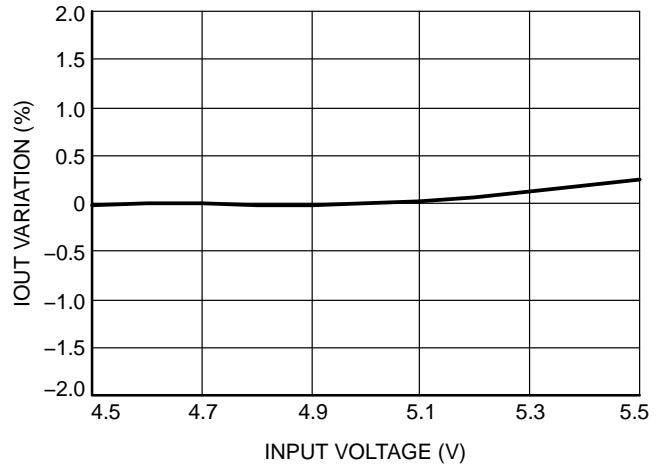

Figure 9. Output Current Regulation

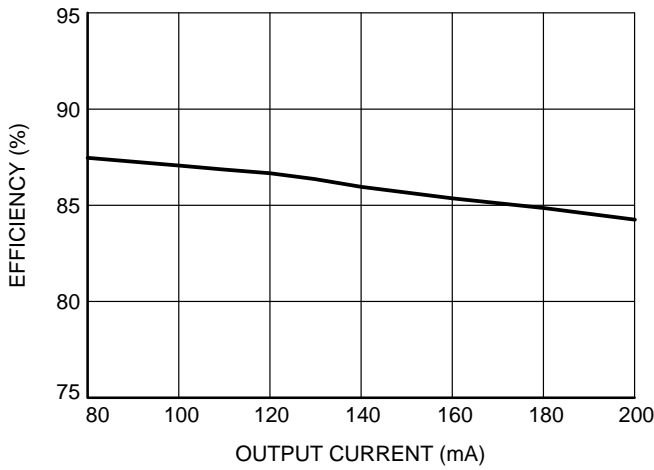

Figure 10. Efficiency vs. Output Current

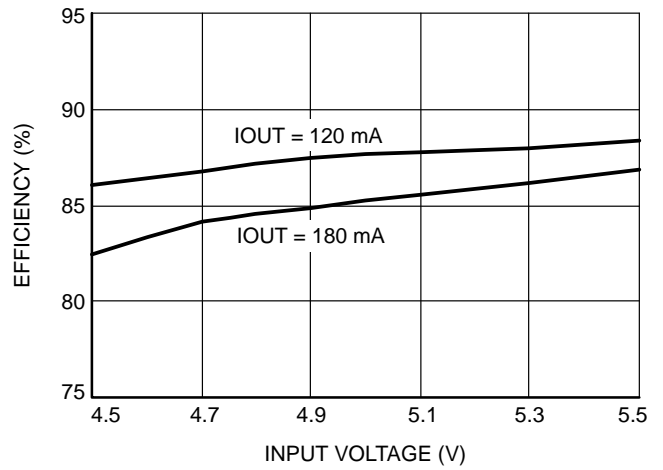

Figure 11. Efficiency vs. Input Voltage

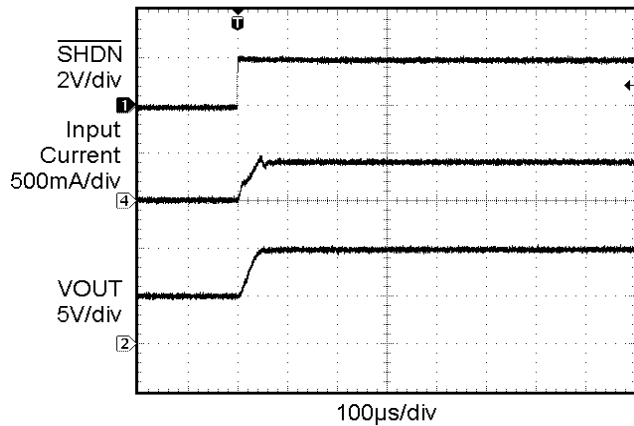

Figure 12. Power-up at 180 mA

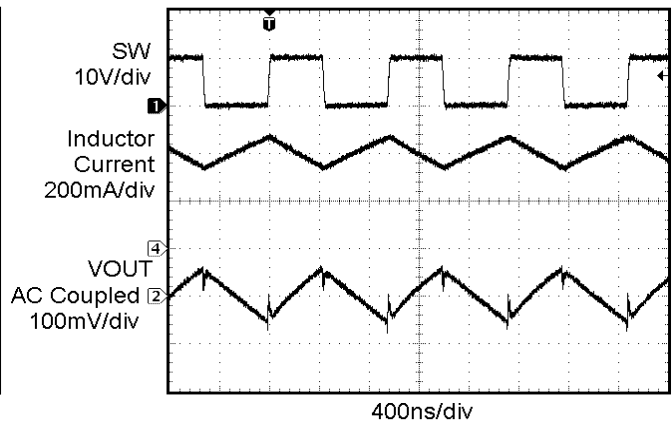

Figure 13. Switching Waveform

TYPICAL CHARACTERISTICS

( $V_{IN} = 5.0\text{ V}$ ,  $I_{OUT} = 180\text{ mA}$ ,  $T_{AMB} = 25^\circ\text{C}$ , with typical application circuit unless otherwise specified.)

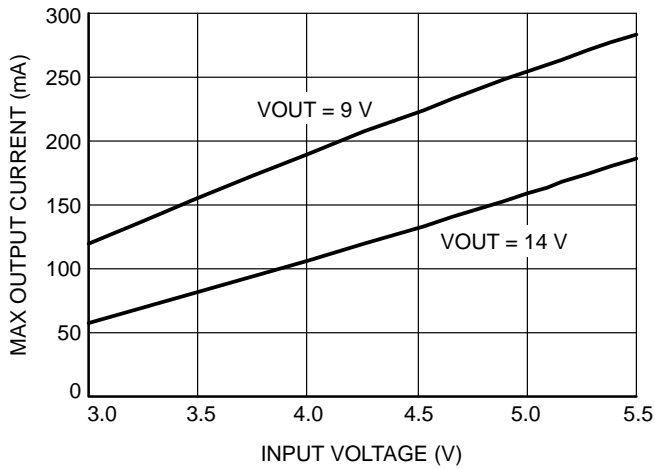

Figure 14. Maximum Output Current

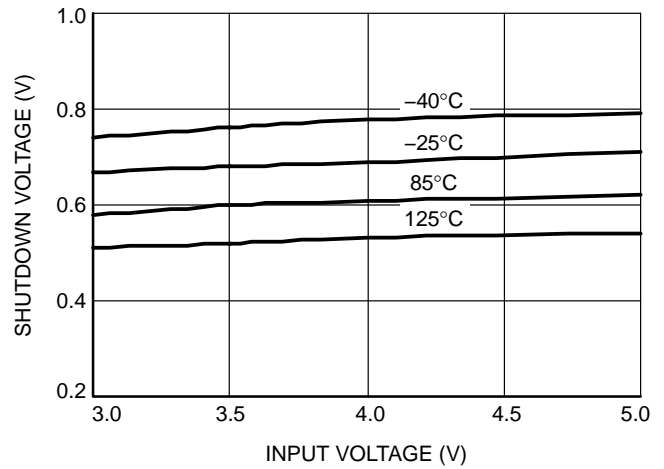

Figure 15. Shutdown Voltage

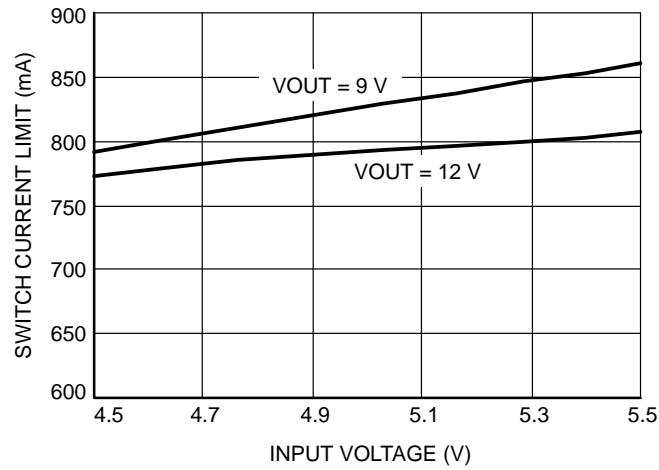

Figure 16. Switch Current Limit

**Pin Description**

**V<sub>IN</sub>** is the supply input for the internal logic. The device is compatible with supply voltages down to 2.8 V and up to 5.5 V. It is recommended that a small bypass ceramic capacitor (4.7 μF) be placed between the V<sub>IN</sub> and GND pins near the device. If the supply voltage drops below 1.9 V, the device stops switching.

**SHDN** is the shutdown logic input. When the pin is tied to a voltage lower than 0.4 V, the device is in shutdown mode, drawing nearly zero current. When the pin is connected to a voltage higher than 1.5 V, the device is enabled.

**GND** is the ground reference pin. This pin should be connected directly to the ground plane on the PCB.

**SW** pin is connected to the drain of the internal CMOS power switch of the boost converter. The inductor and the Schottky diode anode should be connected to the SW pin. Traces going to the SW pin should be as short as possible with minimum loop area. An over-voltage detection circuit is connected to the SW pin. When the voltage reaches 24 V, the device enters a low power operating mode preventing the SW voltage from exceeding the maximum rating.

**FB** feedback pin is regulated at 0.3 V. A resistor connected between the FB pin and ground sets the LED current according to the formula:

$$I_{LED} = \frac{0.3 V}{R1}$$

The lower LED cathode is connected to the FB pin.

**Table 4. PIN DESCRIPTIONS**

Pin #	Name	Function
1	SW	Switch pin. This is the drain of the internal power switch.
2	GND	Ground pin. Connect the pin to the ground plane.
3	FB	Feedback pin. Connect to the last LED cathode.
4	SHDN	Shutdown pin (Logic Low). Set high to enable the driver.
5	VIN	Power Supply input.

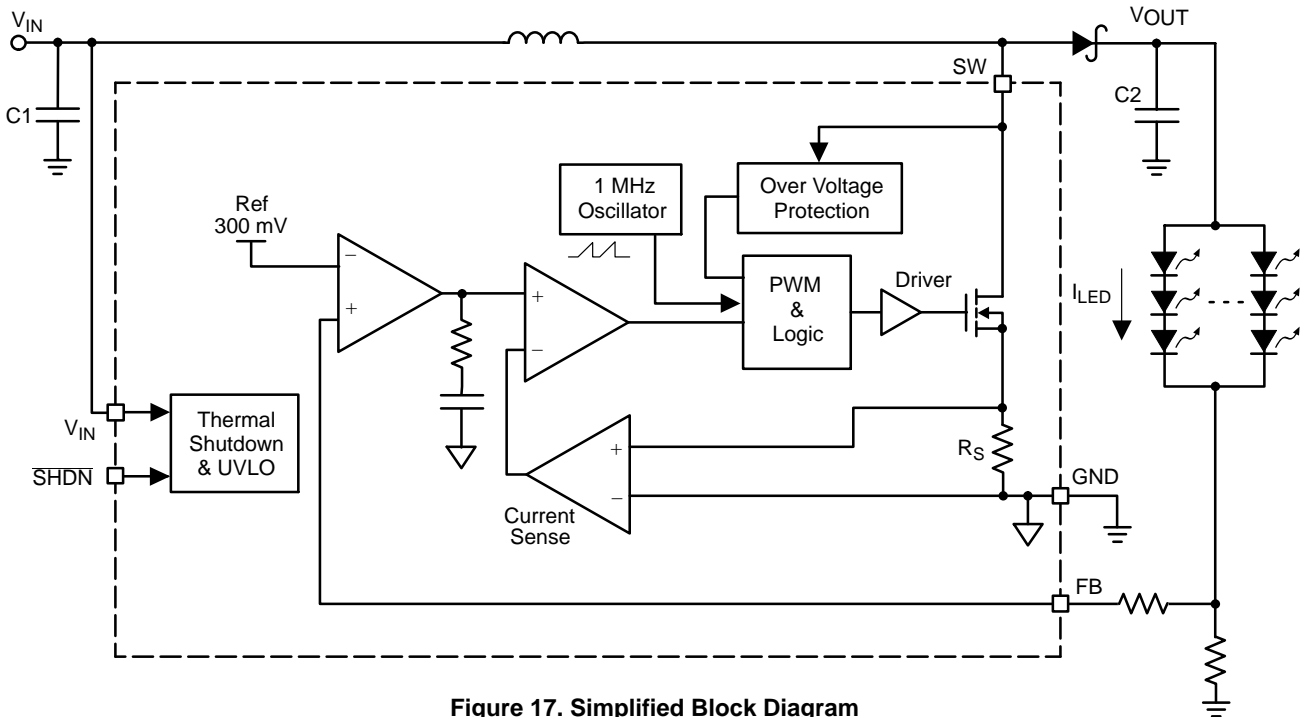

**Figure 17. Simplified Block Diagram**

**Device Operation**

The CAT4139 is a fixed frequency (1 MHz), low noise, inductive boost converter that provides a constant current with excellent line and load regulation. The device uses a high-voltage CMOS power switch between the SW pin and ground to energize the inductor. When the switch is turned off, the stored energy in the inductor is released into the load via the Schottky diode.

The on/off duty cycle of the power switch is internally adjusted and controlled to maintain a constant regulated voltage of 0.3 V across the feedback resistor connected to the feedback pin (FB). The value of the resistor sets the LED current accordingly (0.3 V/R1).

During the initial power-up stage, the duty cycle of the internal power switch is limited to prevent excessive in-rush

currents and thereby provide a “soft-start” mode of operation.

In the event of an “Open LED” fault condition, where the feedback control loop becomes open, the output voltage will continue to increase. Once this voltage exceeds 24 V, an internal protection circuit will become active and place the device into a very low power safe operating mode.

Thermal overload protection circuitry has been included to prevent the device from operating at unsafe junction temperatures above 150°C. In the event of a thermal overload condition the device will automatically shutdown and wait till the junction temperatures cools to 130°C before normal operation is resumed.

**Application Information**

**External Component Selection**

**Capacitors**

The CAT4139 only requires small ceramic capacitors of 4.7 µF on the input and 1 µF on the output. Under normal condition, a 4.7 µF input capacitor is sufficient. For applications with higher output power, a larger input capacitor of 10 µF may be appropriate. X5R and X7R capacitor types are ideal due to their stability across temperature range.

**Inductor**

A 22 µH inductor is recommended for most of the CAT4139 applications. In cases where the efficiency is critical, inductances with lower series resistance are preferred. Inductors with current rating of 800 mA or higher are recommended for most applications. Sumida CDRH6D28-220 22 µH inductor has a rated current of 1.2 A and a series resistance (D.C.R.) of 128 mΩ typical.

**Schottky Diode**

The current rating of the Schottky diode must exceed the peak current flowing through it. The Schottky diode performance is rated in terms of its forward voltage at a given current. In order to achieve the best efficiency, this

forward voltage should be as low as possible. The response time is also critical since the driver is operating at 1 MHz. Central Semiconductor Schottky rectifier CMSH1-40 (1 A rated) is recommended for most applications.

**LED Current Setting**

The LED current is set by the external resistor R1 connected between the feedback pin (FB) and ground. The formula below gives the relationship between the resistor and the current:

$$R1 = \frac{0.3 \text{ V}}{\text{LED current}}$$

**Table 5. RESISTOR R1 AND LED CURRENT**

LED Current (mA)	R1 (Ω)
20	15
25	12
30	10
100	3
300	1



**Open LED Protection**

In the event of an “Open LED” fault condition, the CAT4139 will continue to boost the output voltage with maximum power until the output voltage reaches approximately 24 V. Once the output exceeds this level, the internal circuitry immediately places the device into a very low power mode where the total input power is limited to about 6 mW (about 1.6 mA input current with a 3.6 V supply). The SW pin clamps at a voltage below its maximum rating of 40 V. There is no need to use an external zener diode between VOUT and the FB pin. A 35 V rated C2 capacitor is required to prevent any overvoltage damage in the open LED condition.

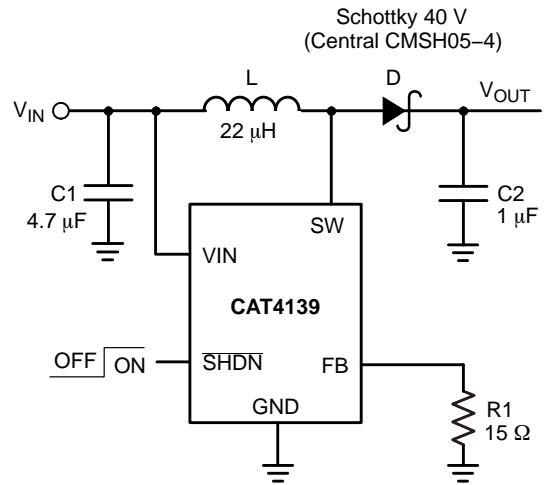

**Figure 18. Open LED Protection Circuit**

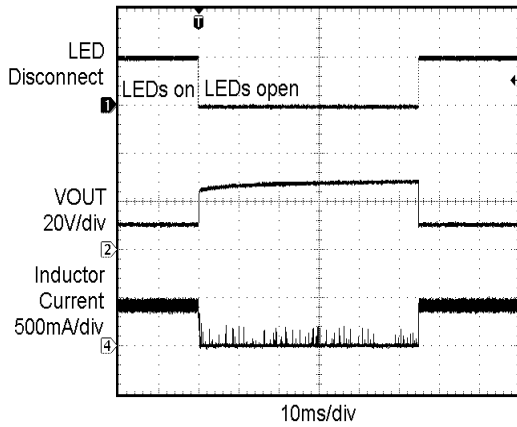

**Figure 19. Open LED Disconnect and Reconnect**

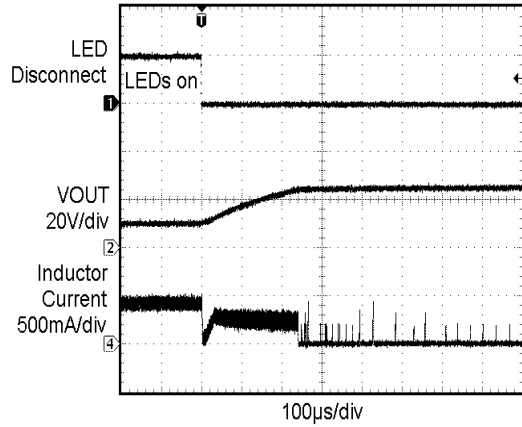

**Figure 20. Open LED Disconnect**

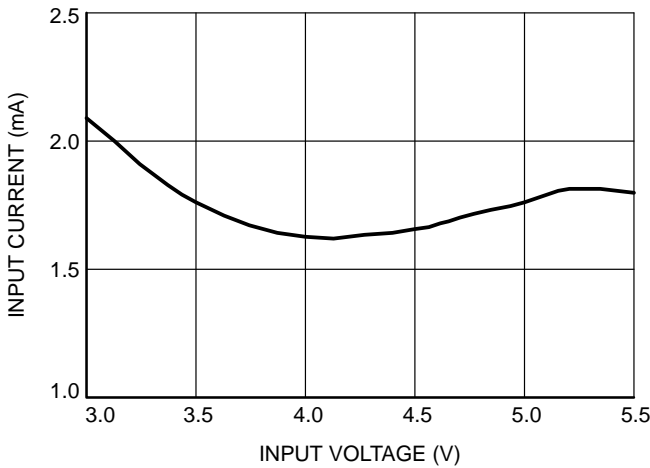

**Figure 21. Open LED Supply Current**

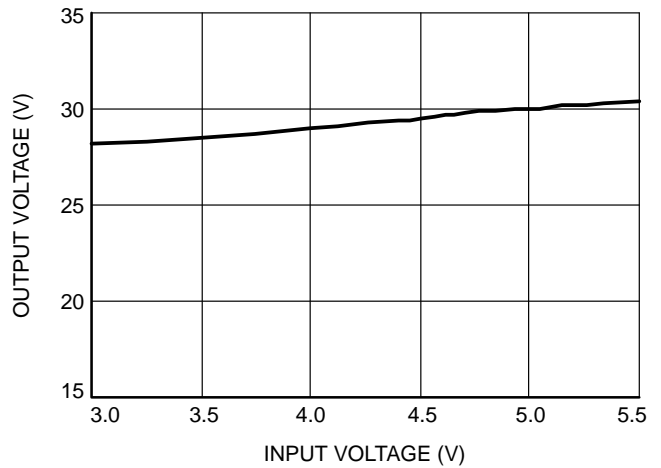

**Figure 22. Open LED Output Voltage**

**Dimming Control**

There are several methods available to control the LED brightness.

**PWM Signal on the  $\overline{\text{SHDN}}$  Pin**

LED brightness dimming can be done by applying a PWM signal to the  $\overline{\text{SHDN}}$  input. The LED current is repetitively turned on and off, so that the average current is proportional to the duty cycle. A 100% duty cycle, with  $\overline{\text{SHDN}}$  always high, corresponds to the LEDs at nominal current. Figure 23 shows a 1 kHz signal with a 50% duty cycle applied to the  $\overline{\text{SHDN}}$  pin. The recommended PWM frequency range is from 100 Hz to 2 kHz.

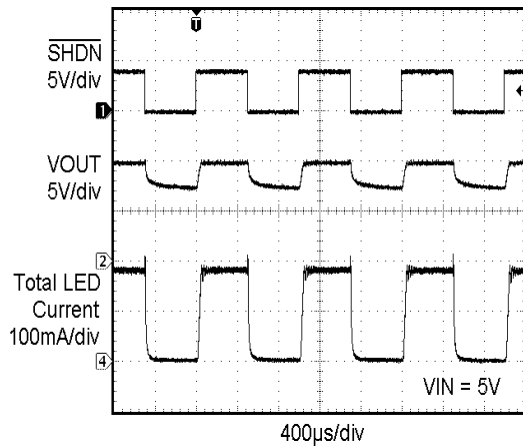

**Figure 23. Switching Waveform with 1 kHz PWM on  $\overline{\text{SHDN}}$**

**Filtered PWM Signal**

A filtered PWM signal used as a variable DC voltage can control the LED current. Figure 24 shows the PWM control circuitry connected to the CAT4139 FB pin. The PWM signal has a voltage swing of 0 V to 2.5 V. The LED current can be dimmed within a range from 0 mA to 20 mA. The PWM signal frequency can vary from very low frequency and up to 100 kHz.

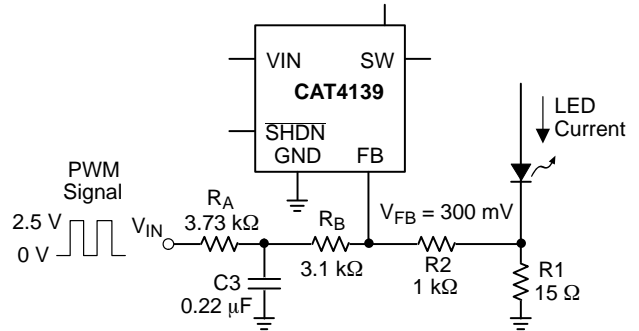

**Figure 24. Circuit for Filtered PWM Signal**

A PWM signal at 0 V DC, or a 0% duty cycle, results in a max LED current of about 22 mA. A PWM signal with a 93% duty cycle or more, results in an LED current of 0 mA.

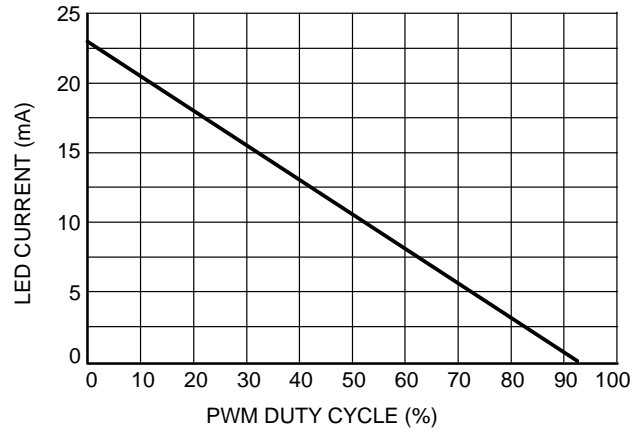

**Figure 25. Filtered PWM Dimming (0 V to 2.5 V)**

# CAT4139

## Board Layout

The CAT4139 is a high-frequency switching regulator. The traces that carry the high-frequency switching current have to be carefully laid out on the board in order to minimize EMI, ripple and noise in general. The thicker lines on Figure 26 show the switching current path. All these traces have to be short and wide enough to minimize the parasitic inductance and resistance. The loop shown on Figure 26 corresponds to the current path when the CAT4139 internal switch is closed. On Figure 27 is shown

the current loop, when the CAT4139 switch is open. Both loop areas should be as small as possible.

Capacitor C1 has to be placed as close as possible to the VIN pin and GND. The capacitor C2 has to be connected separately to the top LED anode. A ground plane under the CAT4139 allows for direct connection of the capacitors to ground. The resistor R1 must be connected directly to the GND pin of the CAT4139 and not shared with the switching current loops and any other components.

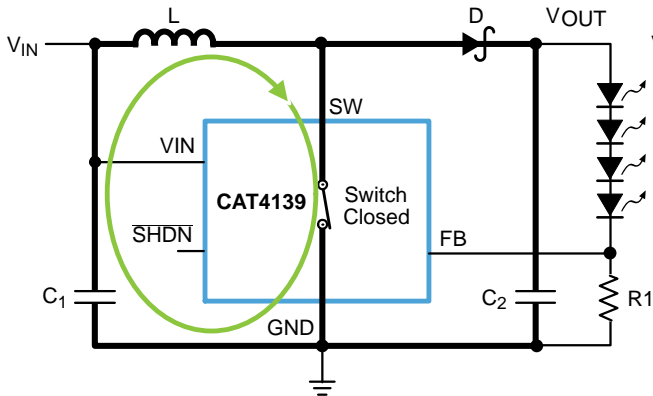

Figure 26. Closed-switch Current Loop

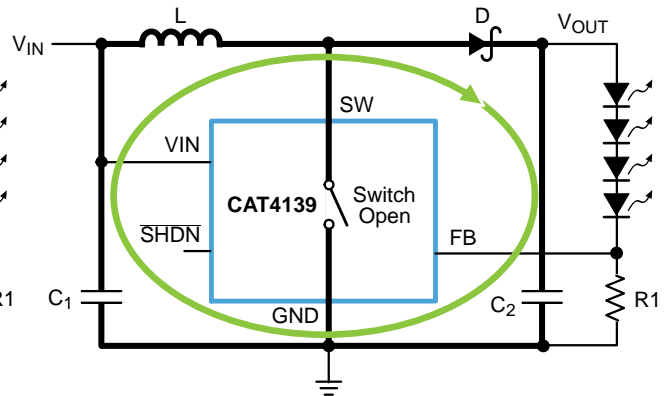

Figure 27. Open-switch Current Loop

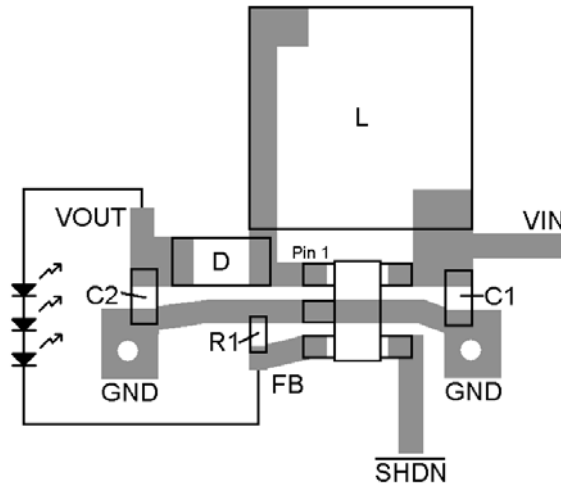
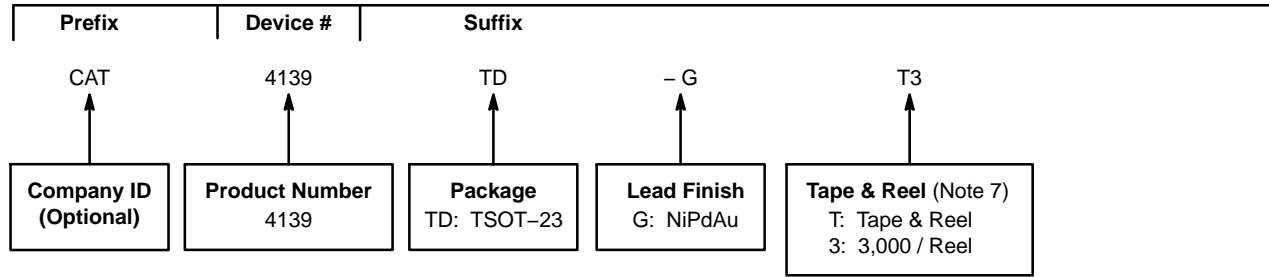

Figure 28. Recommended PCB Layout

# CAT4139

## Example of Ordering Information (Note 5)



## SERIES LED DRIVERS

Part Number	Description
CAT4137	CMOS Boost Converter – White LED Driver
CAT4237	High Voltage CMOS Boost White LED Driver
CAT4238	High Efficiency 10 LED Boost Converter
CAT4139	22 V High Current Boost White LED Driver
CAT4240	6 Watt Boost LED Driver

3. All packages are RoHS-compliant (Lead-free, Halogen-free).
4. The standard lead finish is NiPdAu.
5. The device used in the above example is a CAT4139TD-GT3 (TSOT-23, NiPdAu, Tape & Reel, 3,000/Reel).
6. For additional package and temperature options, please contact your nearest ON Semiconductor Sales office.
7. For information on tape and reel specifications, including part orientation and tape sizes, please refer to our Tape and Reel Packaging Specifications Brochure, BRD8011/D.

# MECHANICAL CASE OUTLINE

## PACKAGE DIMENSIONS

ON Semiconductor®



TSOT-23, 5 LEAD  
CASE 419AE-01  
ISSUE O

DATE 19 DEC 2008

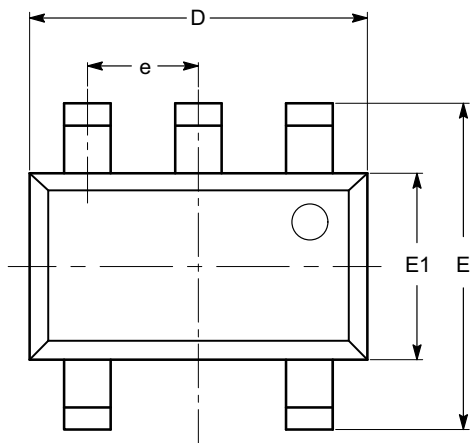

TOP VIEW

SYMBOL	MIN	NOM	MAX
A			1.00
A1	0.01	0.05	0.10
A2	0.80	0.87	0.90
b	0.30		0.45
c	0.12	0.15	0.20
D	2.90 BSC		
E	2.80 BSC		
E1	1.60 BSC		
e	0.95 TYP		
L	0.30	0.40	0.50
L1	0.60 REF		
L2	0.25 BSC		
$\theta$	0°		8°

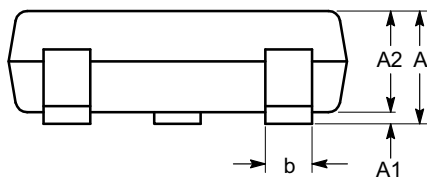

SIDE VIEW

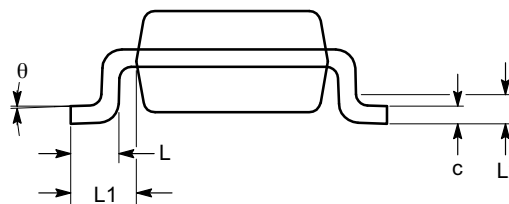

END VIEW

**Notes:**

- (1) All dimensions are in millimeters. Angles in degrees.
- (2) Complies with JEDEC MO-193.

<b>DOCUMENT NUMBER:</b>	<b>98AON34392E</b>	Electronic versions are uncontrolled except when accessed directly from the Document Repository. Printed versions are uncontrolled except when stamped "CONTROLLED COPY" in red.
<b>DESCRIPTION:</b>	<b>TSOT-23, 5 LEAD</b>	<b>PAGE 1 OF 1</b>

ON Semiconductor and are trademarks of Semiconductor Components Industries, LLC dba ON Semiconductor or its subsidiaries in the United States and/or other countries. ON Semiconductor reserves the right to make changes without further notice to any products herein. ON Semiconductor makes no warranty, representation or guarantee regarding the suitability of its products for any particular purpose, nor does ON Semiconductor assume any liability arising out of the application or use of any product or circuit, and specifically disclaims any and all liability, including without limitation special, consequential or incidental damages. ON Semiconductor does not convey any license under its patent rights nor the rights of others.

**onsemi**, **Onsemi**, and other names, marks, and brands are registered and/or common law trademarks of Semiconductor Components Industries, LLC dba "**onsemi**" or its affiliates and/or subsidiaries in the United States and/or other countries. **onsemi** owns the rights to a number of patents, trademarks, copyrights, trade secrets, and other intellectual property. A listing of **onsemi**'s product/patent coverage may be accessed at [www.onsemi.com/site/pdf/Patent-Marking.pdf](http://www.onsemi.com/site/pdf/Patent-Marking.pdf). **onsemi** reserves the right to make changes at any time to any products or information herein, without notice. The information herein is provided "as-is" and **onsemi** makes no warranty, representation or guarantee regarding the accuracy of the information, product features, availability, functionality, or suitability of its products for any particular purpose, nor does **onsemi** assume any liability arising out of the application or use of any product or circuit, and specifically disclaims any and all liability, including without limitation special, consequential or incidental damages. Buyer is responsible for its products and applications using **onsemi** products, including compliance with all laws, regulations and safety requirements or standards, regardless of any support or applications information provided by **onsemi**. "Typical" parameters which may be provided in **onsemi** data sheets and/or specifications can and do vary in different applications and actual performance may vary over time. All operating parameters, including "Typicals" must be validated for each customer application by customer's technical experts. **onsemi** does not convey any license under any of its intellectual property rights nor the rights of others. **onsemi** products are not designed, intended, or authorized for use as a critical component in life support systems or any FDA Class 3 medical devices or medical devices with a same or similar classification in a foreign jurisdiction or any devices intended for implantation in the human body. Should Buyer purchase or use **onsemi** products for any such unintended or unauthorized application, Buyer shall indemnify and hold **onsemi** and its officers, employees, subsidiaries, affiliates, and distributors harmless against all claims, costs, damages, and expenses, and reasonable attorney fees arising out of, directly or indirectly, any claim of personal injury or death associated with such unintended or unauthorized use, even if such claim alleges that **onsemi** was negligent regarding the design or manufacture of the part. **onsemi** is an Equal Opportunity/Affirmative Action Employer. This literature is subject to all applicable copyright laws and is not for resale in any manner.

---

## ADDITIONAL INFORMATION

### TECHNICAL PUBLICATIONS:

Technical Library: [www.onsemi.com/design/resources/technical-documentation](http://www.onsemi.com/design/resources/technical-documentation)  
onsemi Website: [www.onsemi.com](http://www.onsemi.com)

### ONLINE SUPPORT: [www.onsemi.com/support](http://www.onsemi.com/support)

For additional information, please contact your local Sales Representative at [www.onsemi.com/support/sales](http://www.onsemi.com/support/sales)