

# AFBR-59F1Z

125MBd Compact 650 nm Transceiver for Data Communication over **Polymer Optical Fiber (POF)** cables with a bare fiber locking system



## Data Sheet

### Description

The Avago Technologies AFBR-59F1Z transceiver provides system designers with the ability to implement Fast Ethernet (100Mbps) communication over 2.2 mm jacketed standard Polymer Optical Fiber (POF).

The innovative bare fiber locking mechanism of the transceiver allows connection of POF cable with a simple insert and lock system eliminating the need for connectors. This facilitates fast installation and maintenance.

The AFBR-59F1Z is Laser Class 1, lead-free and compliant with RoHS. The very compact design is similar to that of the well known RJ-45 connector.

### Transmitter

The transmitter consists of a 650nm LED which is controlled by a fully integrated driver IC. The LED driver operates at 3.3V. It receives Low Voltage Positive Emitter Coupled Logic (LVPECL) or Low Voltage Differential Signaling (LVDS) differential electrical input and converts it into a modulated current driving the LED. The LED and driver IC are packaged in an optical subassembly.

The optimized lens system of the optical subassembly couples the emitted optical power very efficiently into 1mm core POF cable.

### Receiver

The receiver utilizes a fully integrated single chip solution which provides excellent immunity to EMI and fast transient dV/dt rejection. The receiver directly converts light to a differential LVPECL output signal and operates at 3.3V. The integrated receiver is packaged in an optical subassembly which couples optical power efficiently from POF to the receiving PIN.

The receiver features a signal detect (SD) output. The SD output voltage level is LVPECL.

### Features

- Easy bare fiber termination solution for 2.2mm jacket POF
- EMI/ EMC robust
- Link lengths:  
up to 40 m POF (NA = 0.5) or 60 m POF (NA = 0.3).
- Compatible with IEEE 802.3u Fast Ethernet data communications standard
- LVPECL interface compatible
- Operating temp. range -40 °C to 85 °C
- 3.3 V power supply operation
- Integrated optics to efficiently focus light for fiber coupling
- Electrically compatible with 100BaseFX PHY ICs

### Applications

- Factory automation
- Power generation and distribution system
- Industrial vision system
- Solar panel tracking system
- Home/Office Networking

### Package

The transceiver package contains the two optical subassemblies, which are mounted in the housing for bare fiber connection.

The metal shield on the bare fiber clamp transceiver provides excellent immunity to EMI/EMC

## Pin description and recommended PCB footprint

AFBR-597F1Z has ten active signal pins (including supply voltage and ground pins), two EMI shield solder posts, two additional ground pins, and two mounting posts.

The EMI shield solder posts and additional ground pins are isolated from the transceiver internal circuit and should be connected to the equipment chassis ground or signal ground. Connecting the two additional ground pins to ground provides EMI shielding to the front of the device. Grounding these pins will also provide a ground connection of the POF jacket in order to ground small leakage currents in high voltage applications such as in HVDC installations.

The mounting posts provide additional mechanical strength to hold the transceiver module on the application board.

Figure 1 shows the top view of the PCB footprint and pin-out diagram.

### Pin Descriptions

Pin No.	Name	Symbol	Pin No.	Name	Symbol
1	Data Input (Negative)	TD-	8	Output Signal Detect	SD
2	Data Input (Positive)	TD+	9	Data Output (Negative)	RD-
3	Ground Tx	GND	10	Data Output (Positive)	RD+
4	DC Supply Voltage Tx	Vdd	11	EMI Shield GND	-
5	Ground Tx	GND	12	EMI Shield GND	-
6	DC Supply Voltage Rx	Vdd	13	Additional EMI GND	-
7	Ground Rx	GND	14	Additional EMI GND	-

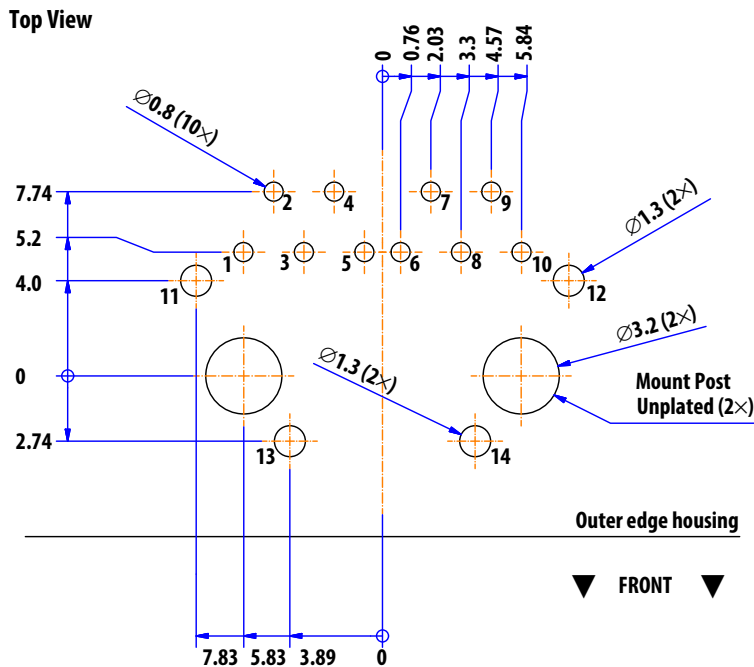

Dimension: mm

Recommended PCB thickness:  $1.57 \pm 0.08$

Figure 1. PCB footprint and pin-out diagram: top view

## Recommended Compliance Table

Feature	Test Method	Performance
Electrostatic discharge (ESD) to the electrical pins	JESD22-A114	Withstands up to 2 kV HBM applied between the electrical pins.
Immunity	Variation of IEC 61000-4-3	Typically shows no measurable effect from a 15 V/m field swept from 8 MHz to 1 GHz applied to the transceiver when mounted on a circuit board without chassis enclosure.
Eye safety	EN 60825-1:52007	Laser Class 1 product (LED radiation only). TÜV certificate: R50217706. Caution – Use of controls or adjustments of performance or procedures other than those specified herein may result in hazardous radiation exposure.

## Absolute Maximum Ratings

Stresses in excess of the absolute maximum ratings can cause catastrophic damage to the device. Limits apply to each parameter in isolation; all other parameters having values within the recommended operation conditions. It should not be assumed that limiting values of more than one parameter can be applied to the products at the same time. Exposure to the absolute maximum ratings for extended periods can adversely affect device reliability.

Parameter	Symbol	Min.	Max.	Units
Supply Voltage	V <sub>dd Max</sub>	-0.5	4.5	V
Storage Temperature	T <sub>STG</sub>	-40	85	°C
Lead Soldering Temperature <sup>[1]</sup>	T <sub>sold</sub>	-	260	°C
Lead Soldering Time <sup>[1]</sup>	t <sub>sold</sub>	-	10	s
Electrostatic Voltage Capability <sup>[2]</sup>	ESD	-	2.0	kV
Installation temperature <sup>[3]</sup>	T <sub>I</sub>	0	50	°C

Notes:

1. The transceiver is Pb-free wave solderable. According to JEDEC J-STD-020D, the moisture sensitivity classification is MSL2a.
2. ESD capability for all pins HBM (Human Body model) according JESD22-A114B
3. Range over which fibers can be connected to or disconnected to/from the bare fiber clamp.

## Recommended Operating Conditions

Parameter	Symbol	Min.	Typ.	Max.	Units	Note
Operating temperature	T <sub>A</sub>	-40	25	85	°C	
DC Supply Voltage	V <sub>dd</sub>	3.0	3.3	3.6	V	
Baud Rate	BR	10	125		MBd	4

Note:

4. Data rate of 100 Mbps with 4b/5b coding.

All the data in this specification refers to the preceding operating conditions and over lifetime, unless otherwise stated.

## Mechanical Characteristics

Parameter	Min.	Typ.	Max.	Units	Temp. [°C]
Fiber/Cable Retention Force [2]	-	30	-	N	25
	10	-	50	N	-40...85 [1]
Clamp opening force	-	20	-	N	25
	10	-	30	N	0...50 [1]
Clamp closing force	-	13	-	N	25
	5	-	20	N	0...50 [1]

Notes:

1. Range over which fibers can be connected/ disconnected to/ from the bare fiber clamp.
2. Measured with Avago's AFBR-HUDxxxZ(2.2mm duplex-fiber, PE-jacket,without connector) with 100mm/ min traction speed.

## Transmitter Electrical Characteristics

Parameter	Symbol	Min.	Typ.	Max.	Units
Current Consumption	I <sub>dd</sub>	-	27	36	mA
Input Capacitance	C <sub>IN</sub>	-	-	5	pF
Input Resistance (differential)	R <sub>IN</sub>	-	10	-	kΩ
Input Common-Mode Range	V <sub>IN-CM</sub>	GND + 0.8	-	V <sub>CC</sub> - 0.8	V
Input Voltage Swing	V <sub>IN-SWING</sub>	200	-	2400	mV

## Transmitter Optical Characteristics (with standard POF NA = 0.5)

Parameter	Symbol	Min.	Typ.	Max.	Units
Central wavelength	λ <sub>C</sub>	635	650	675	nm
Spectral Bandwidth (RMS) [3]	Δλ	-	-	17	nm
Average Output Power [3, 5]	P	-8.5	-	-2.0	dBm
Optical Rise Time (20% - 80%) [3]	t <sub>r</sub>	-	1.2	3.0	ns
Optical Fall Time (80% - 20%) [3]	t <sub>f</sub>	-	1.2	3.0	ns
Extinction Ratio [3]	R <sub>E</sub>	10	-	-	dB
Data Dependent Jitter [3]	DDJ	-	-	0.6	ns
Random Jitter [3,4]	RJ	-	-	0.76	ns
Duty cycle distortion [3]	DCD	-	-	1.0	ns

Notes:

3. Measured at the end of 1 m Plastic Optical Fiber (POF) with PRBS 2<sup>7</sup>-1 sequence.
4. Peak-to-peak measurement, based on BER = 2.5 × 10<sup>-10</sup>
5. Minimum average output power specification value includes 1dB degradation margin.

## Receiver Electrical Characteristics

Parameter	Symbol	Min.	Typ.	Max.	Units
Current Consumption <sup>[1]</sup>	$I_{dd}$	-	41	50	mA
Output Offset Voltage	$(V_{QH}+V_{QL})/2$	-	$V_{dd} - 1.2$	-	V
Output Differential Voltage Swing <sup>[2, 3]</sup>	$[V_{OH}-V_{OL}]$	600	710	800	mV
Output Rise Time (10% - 90%) <sup>[2]</sup>	$t_f$	-	1.1	3.0	ns
Output Fall Time (10% - 90%) <sup>[2]</sup>	$t_f$	-	1.1	3.0	ns
Duty cycle distortion <sup>[2]</sup>	DCD	-	-	1.0	ns
Data dependent + Random Jitter <sup>[2, 4]</sup>	DDJ + RJ	-	-	3.3	ns

Notes:

1. AC-coupled
2. Differential output signal is measured with reference transmitter source, 0.5m POF cable, and PRBS 2<sup>7</sup>-1 sequence
3. Single-ended
4. Peak-to-peak measurement, based on BER = 2.5 x 10<sup>-10</sup>

## Receiver Optical Characteristics

Parameter	Symbol	Min.	Typ.	Max.	Units
Central wavelength	$\lambda_C$	635	650	675	nm
Minimum Receiver Input Power <sup>[5]</sup>	$P_{in Min}$	-23	-	-	dBm
Maximum Receiver Input Power <sup>[5]</sup>	$P_{in Max}$	-	-	-2	dBm
Signal Detect Output Voltage – High <sup>[5, 6]</sup>	$V_{OH} - V_{dd}$	-	-0.8	-	V
Signal Detect Output Voltage – Low <sup>[5, 6]</sup>	$V_{OL} - V_{dd}$	-	-1.7	-	V
Signal Detect Asserted <sup>[7]</sup>	$P_A$	-	-33	-	dBm
Signal Detect De-asserted <sup>[7]</sup>	$P_D$	-	-35	-	dBm
Signal Detect Hysteresis	$P_A - P_D$	-	2.0	-	dB

Notes:

5. Average optical power, measured with a PRBS 2<sup>7</sup>-1 sequence, BER = 2.5 x 10<sup>-10</sup>
6. Termination as shown in figure 3
7. The Signal Detect function is in an electrical HIGH state under normal signaling operation. If the receive optical power falls below the minimum threshold for a period of 100  $\mu$ s, the SD function will toggle to a LOW state.

# Mechanical Data - Package Outline

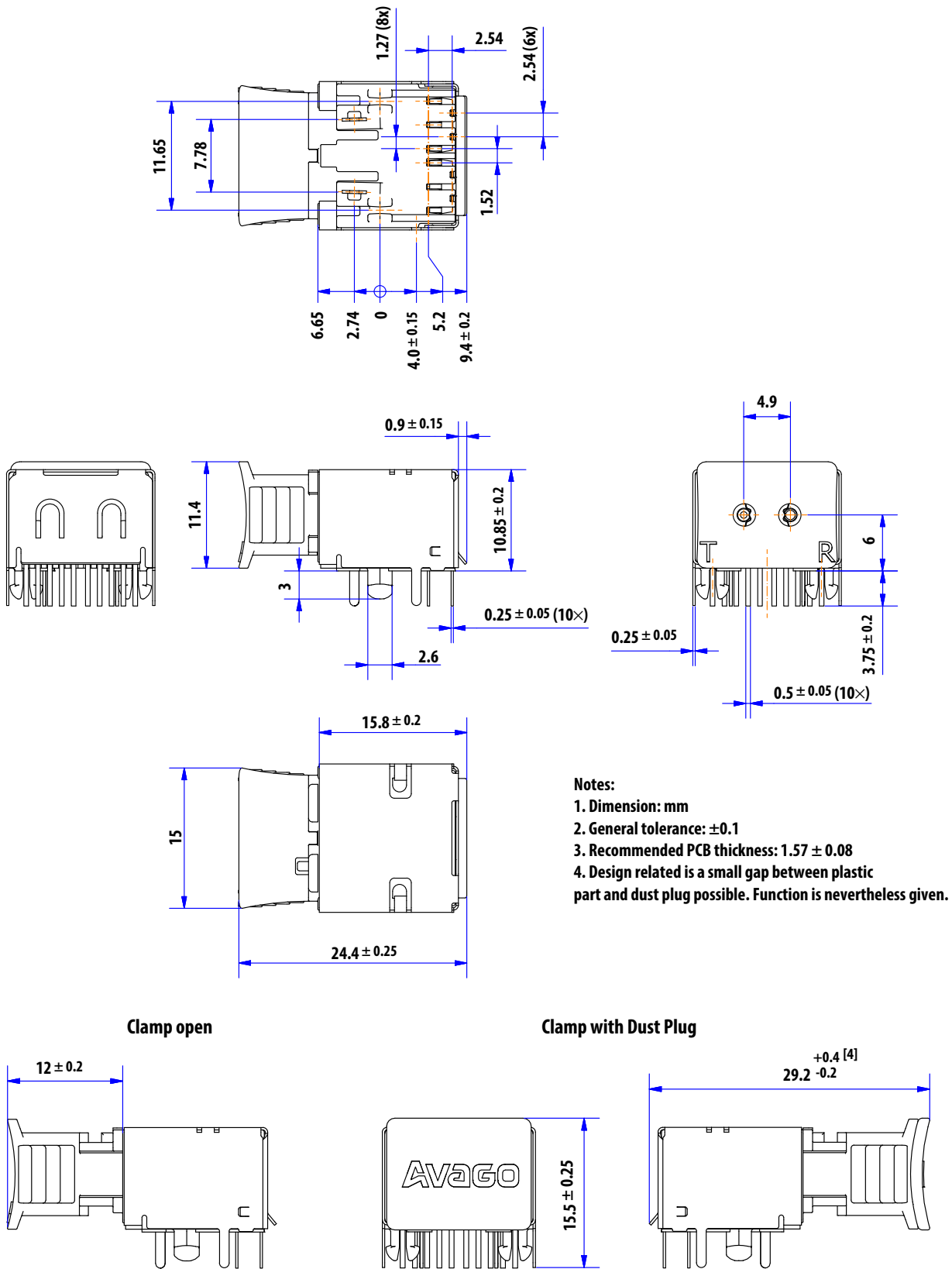

Figure 2. Package Outline Drawing

## General Application Circuit

The recommended application circuit is shown in figure 3.

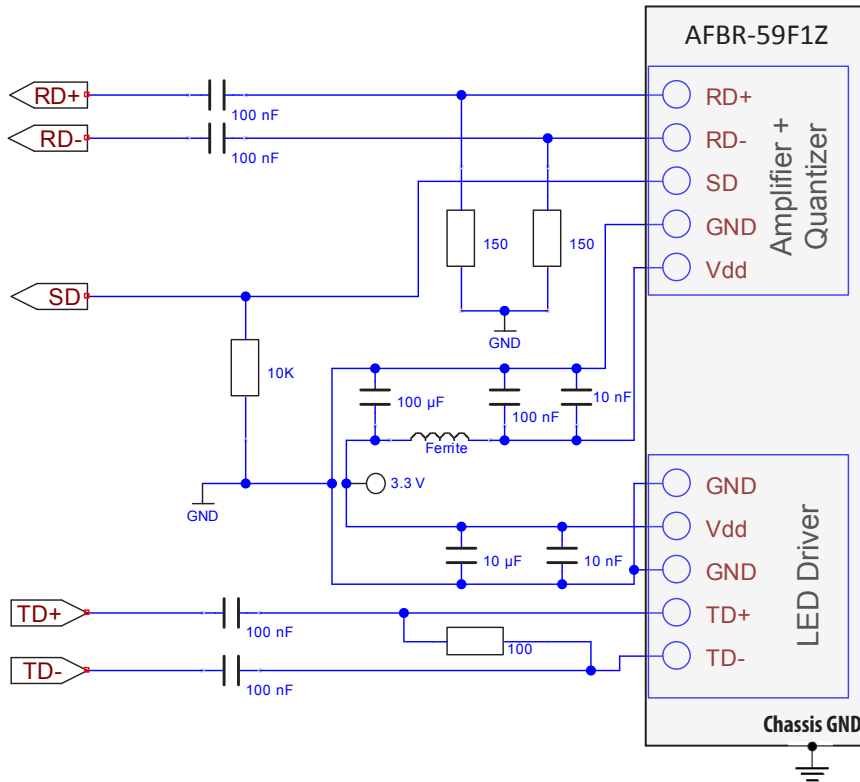

Figure 3. General Application Circuit

## Board layout- Decoupling circuit and Ground Planes

To achieve optimum performance from the AFBR-59F1Z transceiver module it is important to take note of the following recommendations; A power supply decoupling circuit should be used to filter out noise and assure optical product performance; A contiguous signal ground plane should be provided directly beneath transmitter and receiver for low inductance ground to signal return current; The shield posts should be connected to chassis ground or signal ground to provide optimum EMI and ESD performance. These recommendations are in keeping with good high frequency board layout practices. The optimum grounding strategy will depend on customer overall system architecture.

Figure 3 shows the minimum external circuitry between AFBR-59F1Z transceiver module and PHY chip. Please use the product information of the actual PHY chip for connecting to the AFBR-59F1Z.



**Figure 4. AFBR-59F1Z with dust plug**



**Figure 5. AFBR-59F1Z without dust plug**

For product information and a complete list of distributors, please go to our web site: [www.avagotech.com](http://www.avagotech.com)

Avago, Avago Technologies, and the A logo are trademarks of Avago Technologies in the United States and other countries. Data subject to change. Copyright © 2005-2015 Avago Technologies. All rights reserved.  
AV02-4107EN - February 16, 2015

