

# SMD MOLDED WOUND CHIP INDUCTOR

**AISM-1812H**



RoHS/RoHS II compliant



4.2 x 3.2 x 3.2mm

## FEATURES:

- High current version of AISM-1812 with high Q
- Exceptionally reliable over wide operating temperature and under humid environment
- Resilient to mechanical shocks
- Terminals constructed to withstand excessive pulling force
- Suitable for RoHS compliant reflow soldering

## APPLICATIONS:

- VCR, Video Camera
- LCD TV, portable VCR
- HDD

## STANDARD SPECIFICATIONS:

PARAMETERS	
ABRACON P/N:	AISM-1812H-xxx Series
Operating temperature	-40°C to +125°C
Storage temperature:	+5°C to +40°C, Humidity < 70%RH

Part No. AISM-1812H- Inductance Code	L(μH)	Tolerance	Q	Test Freq.	SRF(MHz)	DCR(Ω)	Idc(mA)
		%	(min)	(MHz)	(min)	(max)	(max)
AISM-1812H-1R0	1.0	K	10	7.96	100	0.11	1050
AISM-1812H-1R2	1.2	K	10	7.96	90	0.12	1000
AISM-1812H-1R5	1.5	K	10	7.96	80	0.15	950
AISM-1812H-1R8	1.8	K	10	7.96	70	0.16	900
AISM-1812H-2R2	2.2	K	10	7.96	65	0.18	850
AISM-1812H-2R7	2.7	K	10	7.96	60	0.20	800
AISM-1812H-3R3	3.3	K	10	7.96	45	0.22	750
AISM-1812H-3R9	3.9	K	10	7.96	40	0.24	700
AISM-1812H-4R7	4.7	K	10	7.96	35	0.27	650
AISM-1812H-5R6	5.6	K	10	7.96	30	0.30	650
AISM-1812H-6R8	6.8	K	10	7.96	28	0.35	600
AISM-1812H-8R2	8.2	K	10	7.96	25	0.40	600
AISM-1812H-100	10	K	10	2.52	22	0.50	550
AISM-1812H-120	12	K	10	2.52	21	0.60	500
AISM-1812H-150	15	K	10	2.52	20	0.70	450
AISM-1812H-180	18	K	10	2.52	19	0.80	400
AISM-1812H-220	22	K	10	2.52	18	0.90	370
AISM-1812H-270	27	K	10	2.52	16	1.20	330
AISM-1812H-330	33	K	10	2.52	14	1.40	300
AISM-1812H-390	39	K	10	2.52	12	1.60	280
AISM-1812H-470	47	K	10	2.52	11.5	1.90	260
AISM-1812H-560	56	K	10	2.52	11.0	2.20	240
AISM-1812H-680	68	K	10	2.52	10.0	2.60	220
AISM-1812H-820	82	K	10	2.52	9.0	3.50	200
AISM-1812H-101	100	K	20	0.796	8.0	4.00	180
AISM-1812H-121	120	K	20	0.796	7.5	4.50	160
AISM-1812H-151	150	K	20	0.796	7	6.50	140
AISM-1812H-181	180	K	20	0.796	6.5	7.50	120
AISM-1812H-221	220	K	20	0.796	5.5	9.00	120
AISM-1812H-271	270	K	20	0.796	5	11.00	100
AISM-1812H-331	330	K	20	0.796	4	13.00	90

## Test Conditions

Isat:  $\Delta L/L$  (initial)  $\geq$  -10%



5101 Hidden Creek Ln Spicewood TX 78669  
 Phone: 512-371-6159 | Fax: 512-351-8858  
 For terms and conditions of sales, please visit:  
[www.abracon.com](http://www.abracon.com)

REVISED: 1-21-21

ABRACON IS  
 ISO9001-2015  
 CERTIFIED

# SMD MOLDED WOUND CHIP INDUCTOR

AIMS-1812H



RoHS/RoHS II compliant



4.2 x 3.2 x 3.2mm

## OPTIONS & PART IDENTIFICATION:

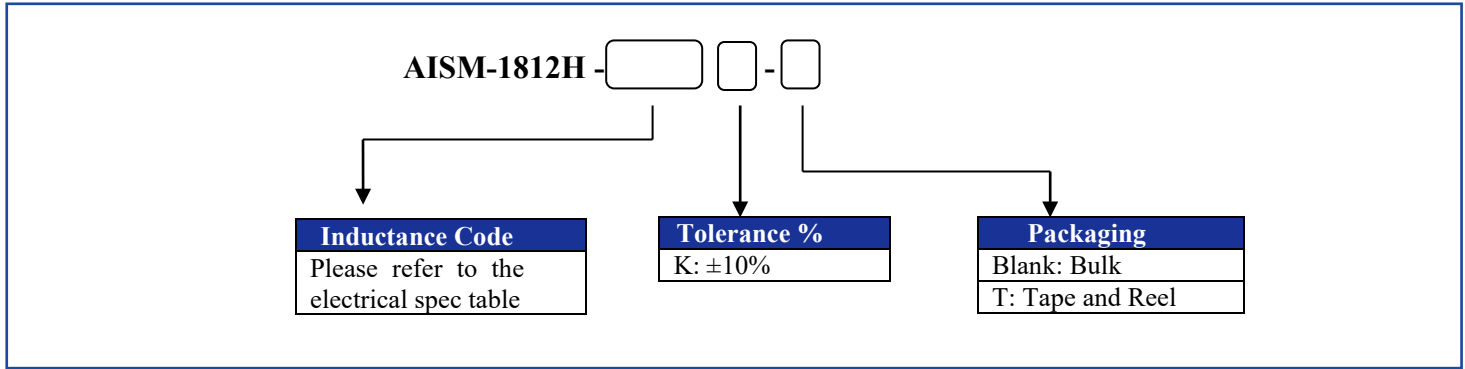

## OUTLINE DIMENSION:

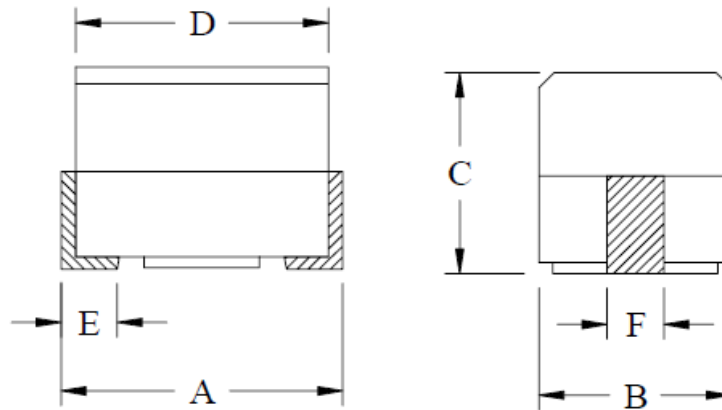

A	B	C	D	E	F
4.5±0.30	3.2±0.20	3.2±0.20	4.2±0.20	0.6±0.10	2.6±0.10

### Recommended Land Pattern

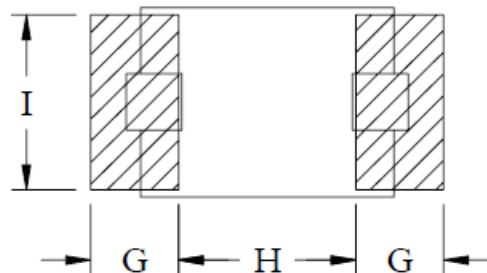

G	H	I
1.50	3.00	2.80

Dimension: mm

# SMD MOLDED WOUND CHIP INDUCTOR

AIMS-1812H



RoHS/RoHS II compliant



4.2 x 3.2 x 3.2mm

## REFLOW PROFILE:

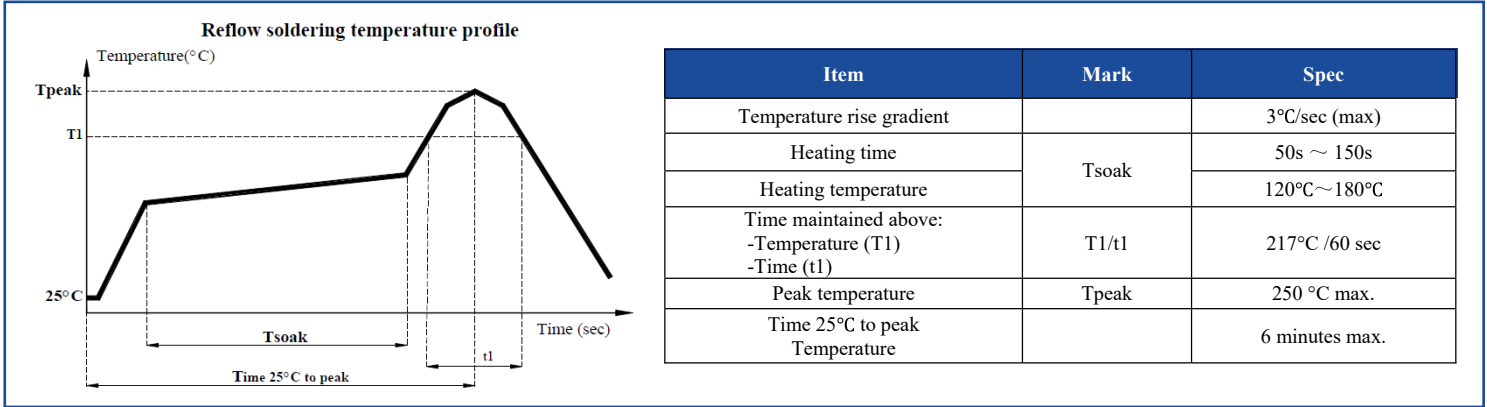

## TAPE & REEL:

Packaging: 2,000 pcs/reel

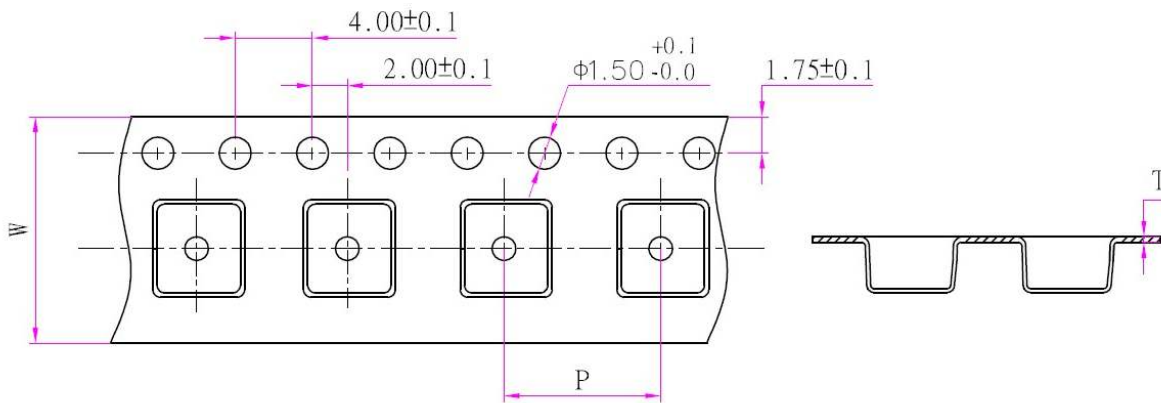

P	T	W
8.0	0.30	12.0

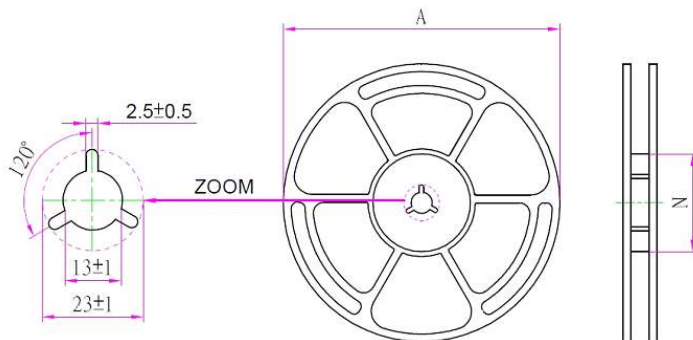

A	N
330	100

Dimensions: mm

**ATTENTION:** Abracon LLC's products are COTS – Commercial-Off-The-Shelf products; suitable for Commercial, Industrial and, where designated, Automotive Applications. Abracon's products are not specifically designed for Military, Aviation, Aerospace, Life-dependent Medical applications or any application requiring high reliability where component failure could result in loss of life and/or property. For applications requiring high reliability and/or presenting an extreme operating environment, written consent and authorization from Abracon LLC is required. Please contact Abracon LLC for more information.



5101 Hidden Creek Ln Spicewood TX 78669  
 Phone: 512-371-6159 | Fax: 512-351-8858  
 For terms and conditions of sales, please visit:  
[www.abracon.com](http://www.abracon.com)

REVISED: 1-21-21

ABRACON IS  
 ISO9001-2015  
 CERTIFIED