

© 1953 BY AMP INCORPORATED. ALL RIGHTS RESERVED. AMP PRODUCTS COVERED BY PATENTS AND OR PATENTS PENDING.

LOC		REVISIONS			
ZONE	LTR	DESCRIPTION	DATE	APPROVED	
G		REDRAWN & REVISED PG-5563	1-6-76	J.H.	
	H	REV. PER ECN P-7000	10/23/70	J.H.	
	J	REV. PER P-8347	9/6/79	J.H.	
	K	OBSOLETE 2--1 P-9222	3-1-82	D.M.	
	L	OBSOLETE 2--2 G-2881	3/8/88	J.H.	
	M	REV PER G-4680	7/2/88	J.H.	

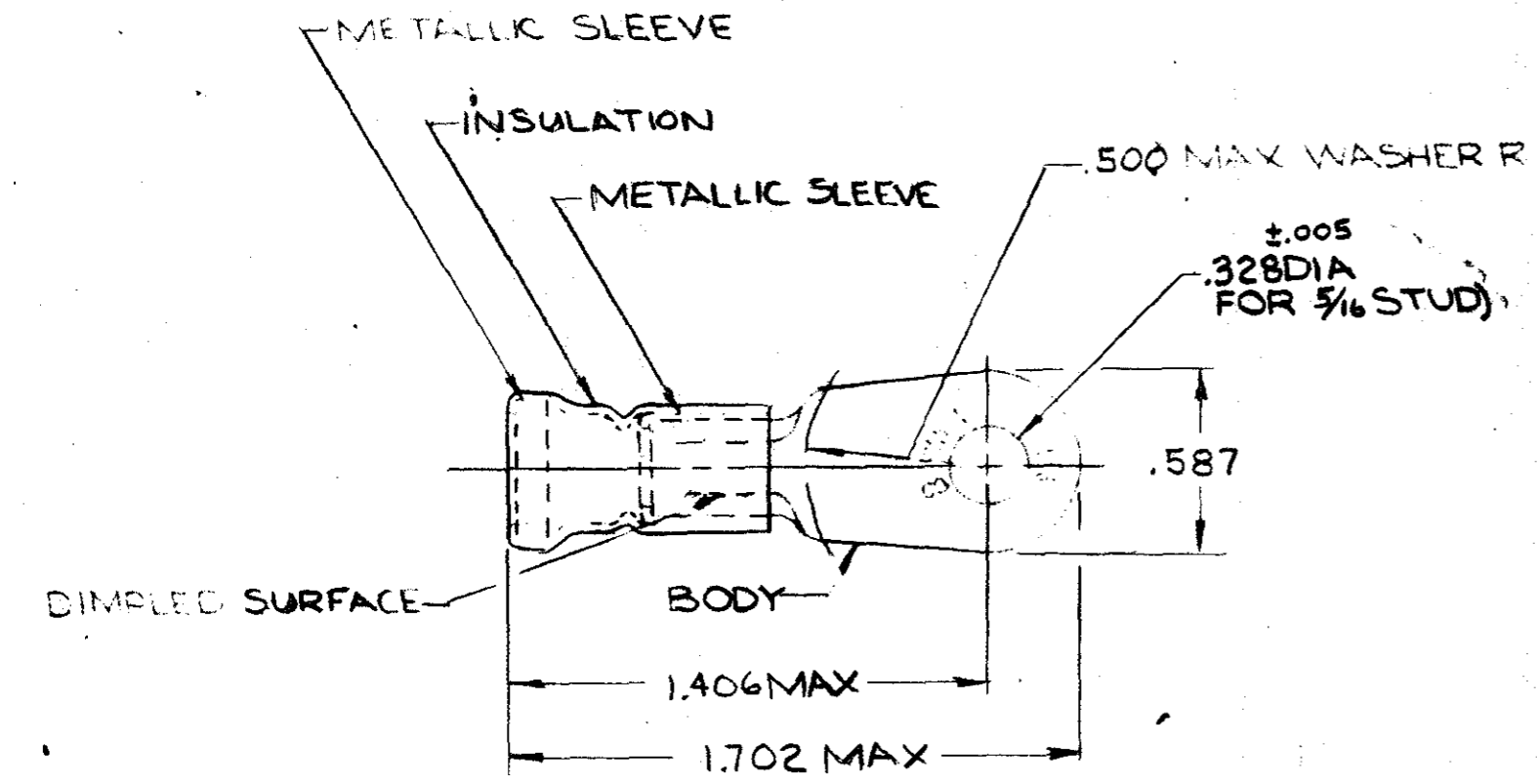

TONGUE MATERIAL THICKNESS = .040 ±.003 FOR .298 MAX WIRE INS DIA

TABLE I

1	WIRE TERMINAL	322003	BODY: COPPER (QQ-C-576) FINISH: (SEE TABLE II) INSULATION: PVC COLOR: RED METALLIC SLEEVE: COPPER (QQ-C-576) METALLIC BAND: STEEL QQ-S-698 (ASTM A109)
QTY	DESCRIPTION	PART NO.	MATERIAL & FINISH
UNLESS OTHERWISE SPECIFIED DIMENSIONS ARE IN INCHES. TOLERANCES ON: DECIMALS ±.008 ANGLES 1°		CONTRACT NO.	AMP INCORPORATED HARRISBURG, PENNSYLVANIA
MATERIAL		DR. J. Kaut 11-14-69	NAME WIRE TERMINAL
SEE TABLE I		CHK M. E. ... 1-6-70	AMPLI-BOND-RING TONGUE
		APPR. L. ... 1-7-70	WIRE SIZE: 8
		REL. M. ... 1-8-70	SIZE B
		DSGN APPR.	CODE IDENT NO. 00779
		OTHER APPR.	NUMBER 322003
			SCALE NTS.
			SHEET 1 OF 1

TABLE II

322003-1	GOLD PL (MIL-G-45204) TYPE II 00005 MIN EXT THK OVER NICKEL PL (QQ-N-290) 00003 MIN EXT THK.		OBSOLETE
322003	TIN PL (MIL-T-10727)	322003-2	OBSOLETE
PART NO.	FINISH	PART No. ON TAPE	

CUSTOMER DRAWING