

Transfer or duplication of this document as well as the utilisation or communication of its content are not permitted unless express consent is granted. Violations give rise to claims for damages. All rights reserved in case of patent, utility model or design patent registrations.

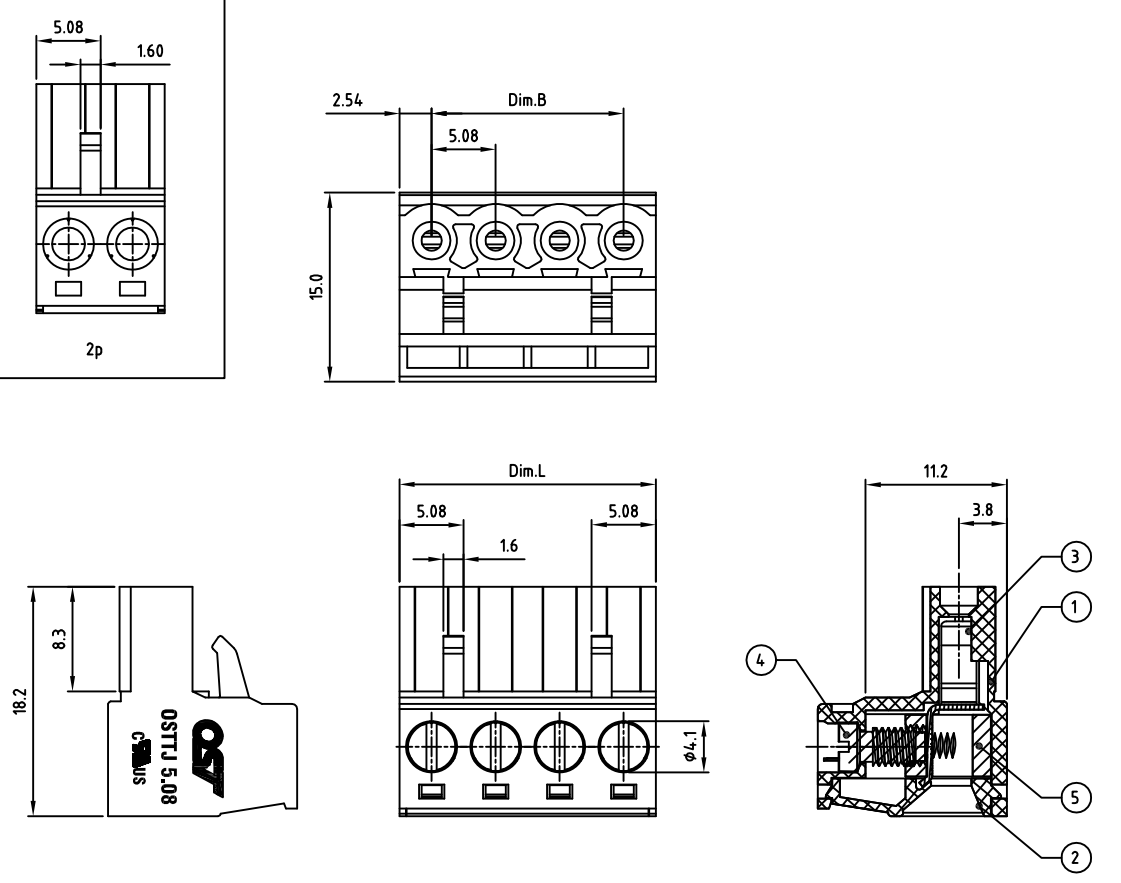

- Technical data**
- Nominal voltage: 300V/15A
PITCH:5.08mm
 - Connection capacity:
AWG 30-12
 - Insulation Withstanding Voltage:
AC 1600V/MIN
 - Insulation Resistance:
1000M Ω or more at DC500V
 - Tightening torque:
5.0kgf.cm (0.5N.m)
 - Screw thread: M3
 - Stripping length: 7-8mm
 - Operating temperature range: -40°C ~ 115°C
 - Undimensioned Tolerances:

Dim.L=Px5.08 Dim.B=(P-1)x5.08 P= number of poles		
	Dim B	Dim L
0-30mm	± 0.15	± 0.20
over 30mm-60mm	± 0.20	± 0.25
over 60mm-90mm	± 0.25	± 0.30
over 90mm	± 0.30	± 0.40

- Safety approval:
- RoHS Compliance

Part No.: **OSTTJXX5153**

No. of Poles	COLOR
02 2 Poles	0: Black
03 3 Poles	2: Red
...	3: Orange
24 24 Poles	4: Yellow
	5: Green (Standard)
	6: Blue
	8: Grey

Nonstandard colors
Mins could apply

5	CAGE	BRASS	M3.0x0.5, Ni PLATED	P
4	SCREW	Steel	M3.0x0.5, Zn Plated	P
3	WIRE GUARD	BRONZE (PhBz)	TIN PLATED	P
2	COVER	PA66 UL94V-0	ALL COLOR	1
1	BODY	PA66 UL94V-0	ALL COLOR	1
ITEM	NAME OF PART	MATERIAL	NOTES	Q'TY
DWG.	Marvin Zhang	DATE	2016.05.19	UNITS: MM SHEET: 1 OF 1 Tolerance
CHK.		DATE		SCALE: NONE 2.5:1 (:) REV.: A
APP.		DATE		TITLE: OSTTJ 5.08 Series "-"
				slot Screw
				PART NO. OSTTJXX5153
				DWG NO. OSTTJXX5153.dwg

	SIGN	DESCRIPTION	CHK.	DATE
--	------	-------------	------	------

OST
ON-SHORE TECHNOLOGY, INC.