

## SPIRIT1- low data rate transceiver - 868 MHz - daughterboard - range extender

Data brief

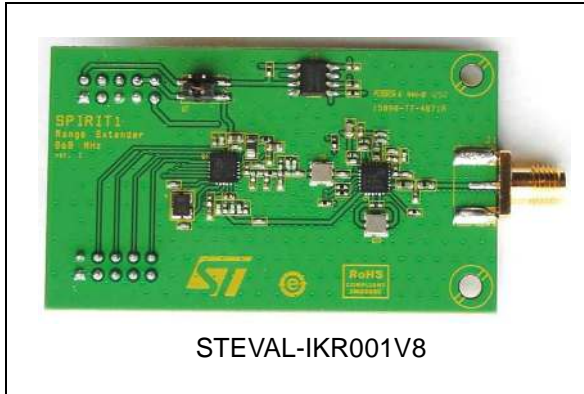

### Description

The STEVAL-IKR001V8D demonstration board is based on the SPIRIT1, a sub GHz low power, low data rate transceiver suitable for ISM bands and wireless M-BUS systems.

The STEVAL-IKR001V8D includes an external power amplifier from SkyWorks®, which allows the application to reach +27 dBm (500 mW) output power.

### Features

- SPIRIT1 low power sub GHz transceiver in a standalone RF module tuned for 868 MHz band with external power amplifier
- Associated SPIRIT1 development kit, including documentation, firmware for STM32L and GUI
- Suitable for wireless M-BUS systems
- Modulation schemes: 2-FSK, GFSK, MSK, GMSK, OOK, and ASK
- Air data rate from 1 to 500 kbps
- TCXO for narrow band requirements
- Max  $P_{OUT}$  +27 dBm
- Excellent receiver sensitivity (up to -123 dBm)
- TX power consumption @ +27 dBm: 350 mA
- SAW filter in reception path to prevent interference from out-of-band signals
- SkyWorks® SEXXXXSL power amplifier
- Low duty cycle RX/TX operation mode
- Automatic acknowledgment, re-transmission and timeout protocol engine
- AES 128-bit encryption co-processor
- SPI interface for microcontroller
- RoHS compliant

# 1 Schematic diagram

Figure 1. STEVAL-IKR001V8D circuit schematic (1 of 2)

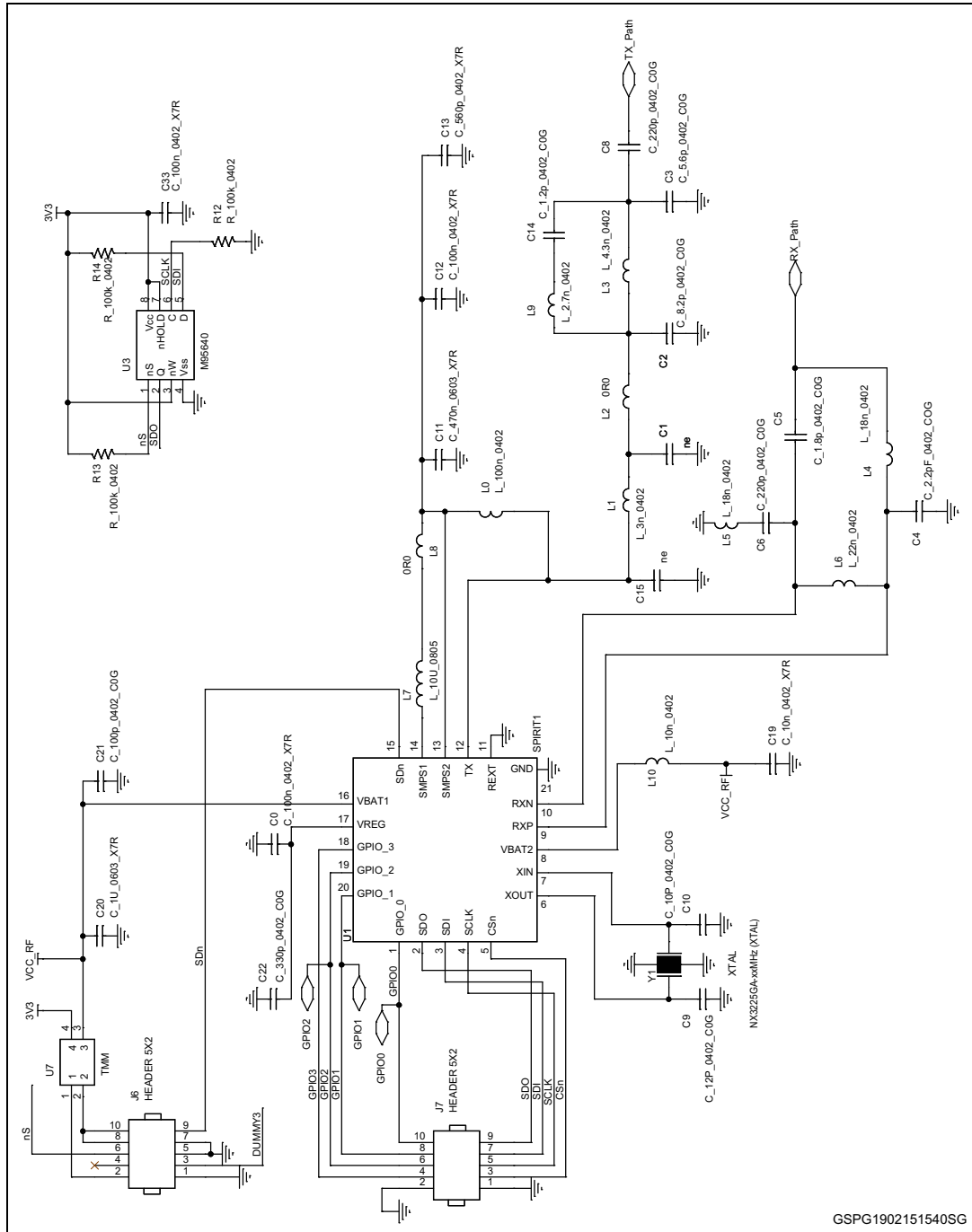
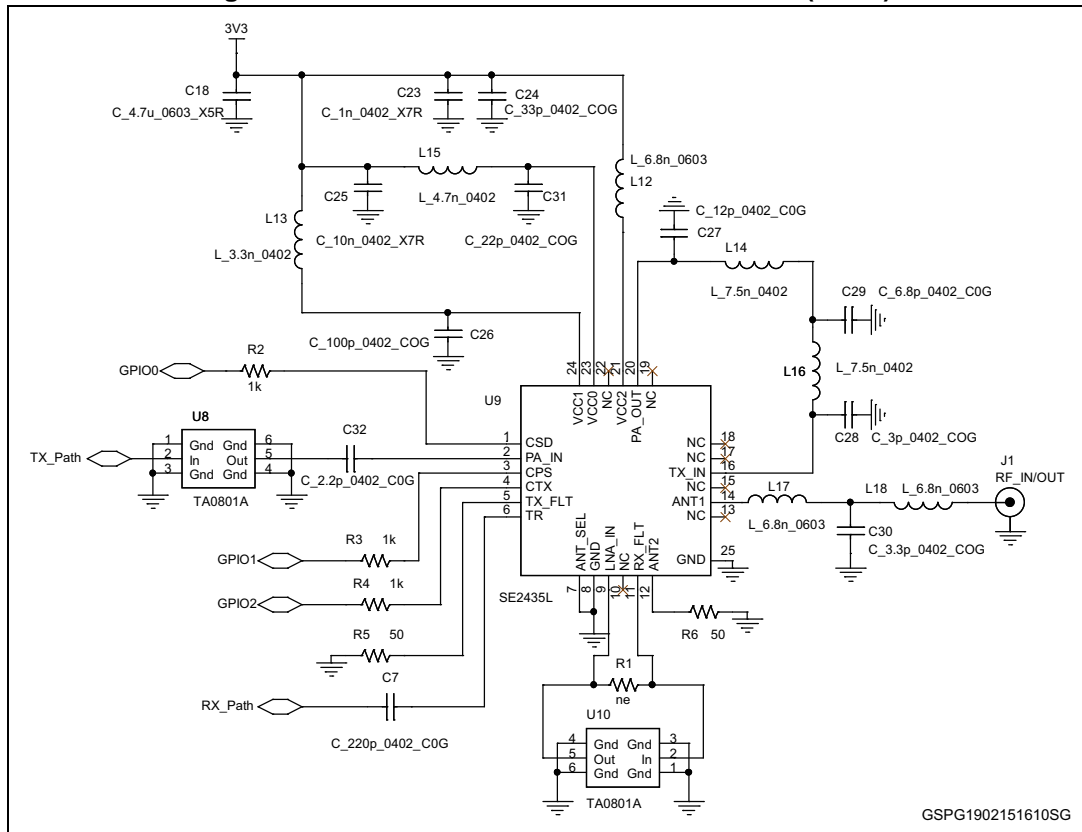

Figure 2. STEVAL-IKR001V8D circuit schematic (2 of 2)



GSPG1902151610SG

## 2 Revision history

Table 1. Document revision history

Date	Revision	Changes
25-Jul-2013	1	Initial release.
02-Apr-2014	2	Title has been modified.
23-Feb-2015	3	Updated: <i>Figure 1</i> Added: <i>Figure 2</i>

**IMPORTANT NOTICE – PLEASE READ CAREFULLY**

STMicroelectronics NV and its subsidiaries ("ST") reserve the right to make changes, corrections, enhancements, modifications, and improvements to ST products and/or to this document at any time without notice. Purchasers should obtain the latest relevant information on ST products before placing orders. ST products are sold pursuant to ST's terms and conditions of sale in place at the time of order acknowledgement.

Purchasers are solely responsible for the choice, selection, and use of ST products and ST assumes no liability for application assistance or the design of Purchasers' products.

No license, express or implied, to any intellectual property right is granted by ST herein.

Resale of ST products with provisions different from the information set forth herein shall void any warranty granted by ST for such product.

ST and the ST logo are trademarks of ST. All other product or service names are the property of their respective owners.

Information in this document supersedes and replaces information previously supplied in any prior versions of this document.

© 2015 STMicroelectronics – All rights reserved

