

NOTES:

1. MATERIALS AND FINISHES:
 BODY - BRASS, NICKEL PLATING
 CONTACT PIN - PHOSPHOR BRONZE, GOLD PLATING
 INSULATORS - PTFE, NATURAL
 LOCK RING - BRASS, NICKEL PLATING
 LOCKWASHER - PHOSPHOR BRONZE, NICKEL PLATING
 HEX NUT - BRASS, NICKEL PLATING
 FERRULE - BRASS, NICKEL PLATING

2. ELECTRICAL:
 A. IMPEDANCE: 75 OHM
 B. FREQUENCY RANGE: DC - 12 GHz
 C. RETURN LOSS (VSWR): -20 dB (1.2) DC - 6 GHz
 -15 dB (1.43) 6 - 12 GHz
 D. DIELECTRIC WITHSTANDING VOLTAGE: 1500 VRMS, MIN.

3. MECHANICAL:
 A. DURABILITY: 500 CYCLES MIN.
 B. TEMPERATURE RANGE: -65°C TO +165°C

4. CABLE ASSEMBLY INSTRUCTIONS
 A. TRIM CABLE AS SHOWN
 B. SLIDE INSULATOR DISC ONTO CABLE CENTER CONDUCTOR
 C. CRIMP CONTACT TO CABLE CENTER CONDUCTOR WITH A .068" HEX DIE
 D. CRIMP FERRULE WITH .324" HEX DIE

THIRD ANGLE PROJ.

REVISIONS

REV	DESCRIPTION	DATE	ECN	APPR
A	RELEASE TO MFG.	04-Jun-19	11721	SV

SHOWS CABLE ENTRY DIMENSIONS

6. PACKAGING:
 A. QUANTITY: SINGLE PACK
 B. MARKING: BAG TO BE MARKED
 "AMPHENOL, 31-70568-12G & DATE CODE"

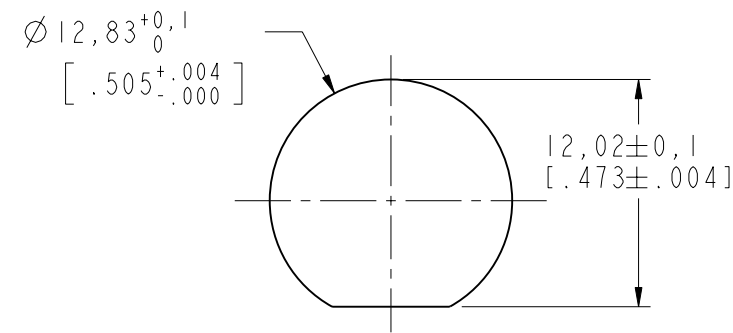

RECOMMENDED MOUNTING
 PANEL DIMENSIONS

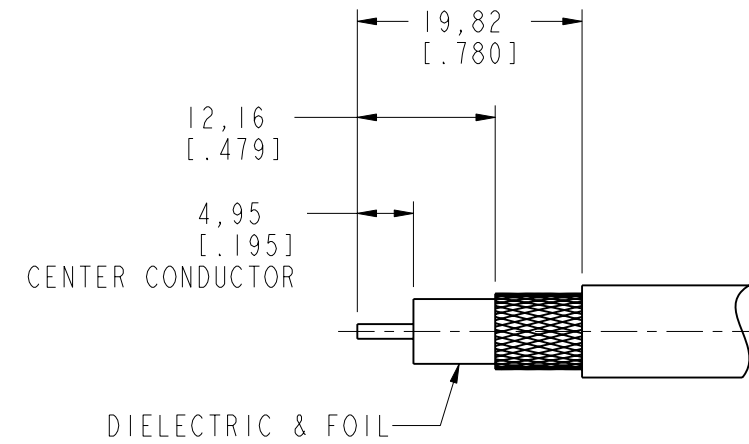

RECOMMENDED
 CABLE STRIPPING DIMENSIONS

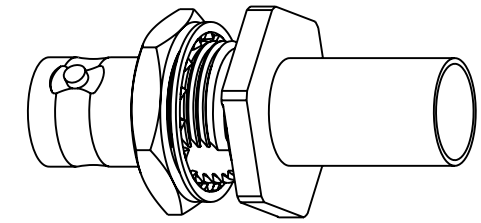

SCALE 1.500

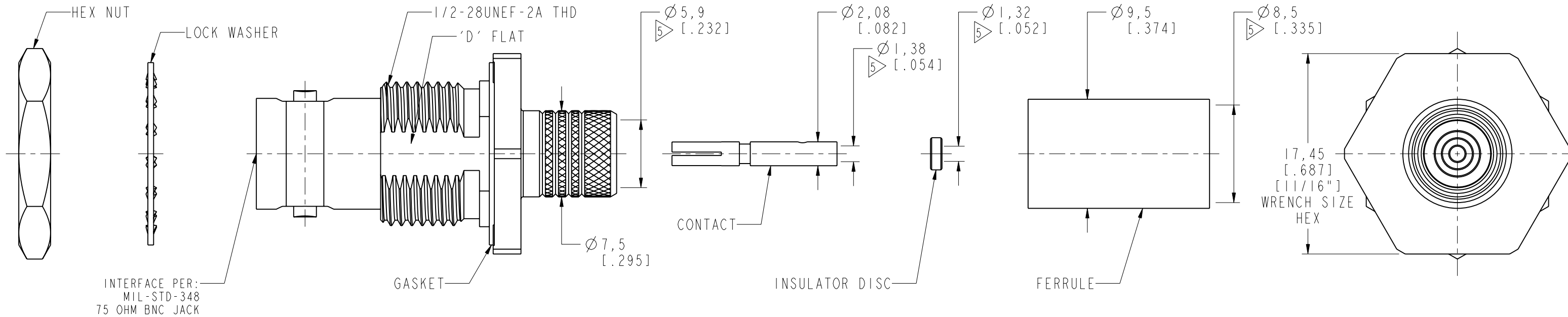

CUSTOMER OUTLINE DRAWING

ALL OTHER SHEETS ARE FOR INTERNAL USE ONLY

UNLESS OTHERWISE SPECIFIED, DIMENSIONS ARE IN METRIC AND TOLERANCES ARE: <0.5mm ± 0.05mm 0.5 - 6mm ± 0.1mm 6 - 30mm ± 0.2mm 30 - 120mm ± 0.3mm ANGLES ± 1°	MATERIAL SEE NOTES	DRAWN M. ZHANG	DATE 04-Jun-19	TITLE BNC BHD JACK FOR BELDEN 4794R CABLE	Amphenol RF www.amphenolrf.com
	REFERENCE EAR# 8870	ENGINEER S. VO	DATE 14-Feb-19		
NOTICE - These drawings, specifications, or other data (1) are, and remain the property of Amphenol corp. (2) must be returned upon request; and (3) are confidential and not to be disclosed to any person other than those to whom they are given by Amphenol Corp. the furnishing of these drawings, specifications, or other data by Amphenol Corp., or to any other person to anyone for any purpose is not to be regarded by implication or otherwise in any manner licensing, granting rights to permitting such holder or any other person to manufacture, use or sell any product, process or design, patented or otherwise, that may in any way be related to or disclosed by said drawings, specifications, or other data.	REF: CONFIGURATION LEVEL: In Work	APPROVED S. HSIEH	DATE 06-Jun-19	SCALE: 3.0:1.0 SHEET 2 OF 2	ITEM NO. 31-70568-12G
	FINISH	CAD FILE	DWG SIZE B	REV A	PART NO. 31-70568-12G