

PART NUMBER	REVISION	DESCRIPTION	FEED TYPE
2150409-1	B	FINE CRIMP HEIGHT ADJUST	MECHANICAL
2150409-2	B	FINE CRIMP HEIGHT ADJUST	PNEUMATIC
7-2150409-1	B	MECHANICAL AND CRIMP TOOLING KIT	MECHANICAL
7-2150409-2	B	PNEUMATIC AND CRIMP TOOLING KIT	PNEUMATIC
7-2150409-7	A	CRIMP TOOLING KIT	-

ATLANTIC VERSION TERMINATOR INTERFACE ADAPTER

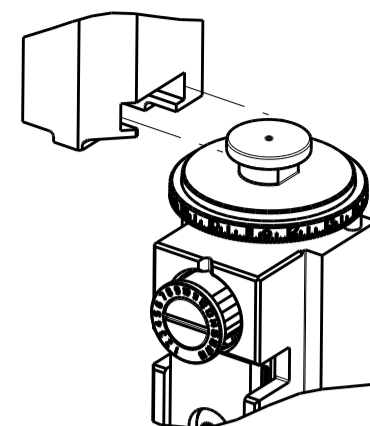

APPLICATOR DATA		
CRIMP	SIZE	TYPE
WIRE	2.97 mm [.117]	F
INSUL	4.01 mm [.158]	F

APPLICATOR INSTRUCTIONS 408-35043

TERMINAL DATA: HATKO TERMINAL HATKO CRIMP SPECIFICATION			
TERMINAL NAME: TERMINAL			
WIRE STRIP LENGTH 5.17-5.18 mm [.204-.204 IN]	INSULATION DIAMETER RANGE Ø 3.05 mm MAX [.120 IN MAX]		
TERMINAL APPLICATION SPECIFICATION	HATKO SPEC		
TERMINALS APPLIED			
TE TERMINAL	HATKO TERMINAL	TE TERMINAL	HATKO TERMINAL
2113425-1	0100104006	2113425-3	0500104006
2113425-2	0300104006		

WIRE SIZE	CRIMP HEIGHT mm [INCH]	CRIMP HEIGHT REFERENCE SETTING
2.50mm2	2.13 +/- 0.02 [.084 +/- .001]	6.7
1.50mm2	1.93 +/- 0.02 [.076 +/- .001]	8.0
1.00mm2	1.85 +/- 0.02 [.073 +/- .001]	8.4

- 1 RECOMMENDED SPARE PARTS
- 2 REFER TO SUPPLIED INSTRUCTION SHEET FOR CLEANING, LUBRICATION AND STORAGE OF APPLICATOR.
- 3 APPLY PART NUMBER 1-23419-5 LOCTITE TO THREADS OF ITEM 50. APPLY PART NUMBER 2-23419-6 LOCTITE TO THREADS OF ITEM 242.
- 4 CRIMP HEIGHT REFERENCE SETTING WAS THE SETTING USED WHEN THE APPLICATOR WAS QUALIFIED AT THE FACTORY. ADJUSTMENT MAY BE NECESSARY WHEN RUNNING APPLICATOR IN THE FIELD.
- 5. UNLESS SPECIFIED OTHERWISE TORQUE VALUES SHALL BE USED PER DOCUMENT, 101-35000.
- 6 TERMINAL LUBRICANT IS RECOMMENDED.

***WARNING**
ON INSTALLATION, SET WIRE DISC TO CRIMP HEIGHT REFERENCE SETTING FOR LARGEST WIRE SIZE. CRIMP HEIGHT REFERENCE SETTINGS GREATER THAN THE VALUE SHOWN MAY CAUSE DAMAGE TO THE CRIMP TOOLING, REFER TO THE INSTRUCTION SHEET FOR PROPER SETUP AND ADJUSTMENTS.

ATLANTIC VERSION
Shown on sheets 1 of 4 & 2 of 4
(Pacific version shown on sheets 3 of 4 & 4 of 4)

LOC	DIST	REVISIONS					
		P	LTN	DESCRIPTION	DATE	OWN	APVD
A	66	1		DEVELOPMENT	12FEB2014	YY	UG
		A		RELEASED	21MAR2014	YY	UG
		B		ECR-20-013680	25SEP2020	FZ	TE

-	1	-	1	-	2119641-1	FEED CAM, AIR FEED	248	
-	1	1	1	1	2119082-3	CAM, SNAIL, INSULATION ADJUSTMENT	244	
-	1	1	1	1	2079764-1	WASHER, WAVE SPRING, CREST-TO-CREST	243	
-	1	1	1	1	2119083-1	RETAINER, INSULATION DIAL	242	
-	-	1	-	1	2119580-1	MECHANICAL FEED ASSEMBLY	239	
-	1	-	1	-	2844940-3	AIR FEED MODULE	238	
-	1	1	1	1	1-18028-0	WASHER, FLAT, REG M8	192	
-	1	1	1	1	6-993111-6	PIN, SLOTTED SPRING 3.0 X 14.0	177	
-	1	1	1	1	8-22280-7	SPRING, COMPRESSION	176	
-	1	1	1	1	1752353-2	GUIDE PIN, HOLDDOWN	175	
-	1	1	1	1	1901680-2	GUIDE PIN, HOLDDOWN	174	
-	REF	REF	REF	REF	994970-2	COUNTER, MAGNETIC	164	
-	1	1	1	1	2119955-2	ASSY, LUBRICATOR, END FEED	84	
-	1	1	1	1	455888-4	SPACER, CRIMPER	82	
-	1	1	1	1	1803607-4	DOCUMENTATION PACKAGE	71	
-	2	2	2	2	2-18032-2	SCR, SET, FLT PNT, M3 X 10.0	70	
-	1	1	1	1	2119740-1	TAG, IDENTIFICATION	67	
-	2	2	2	2	2168078-1	SCREW, DRIVE, RH, RoHS, 2 x .188	66	
-	1	1	1	1	1901681-5	HOLDDOWN, TERMINAL	65	
-	2	2	2	2	2168400-8	SHCS, LOW HEAD, RoHS, M4 X 16	64	
-	1	1	1	1	2168083-2	SCR, SKT HD CAP, RoHS, M4 X 8.0	60	
-	1	1	1	1	5-18022-5	SCR, HEX HD CAP, M4 X 6.0	59	
-	-	1	-	1	2063961-1	FEED FINGER	58	
-	3	3	3	3	2168400-4	SHCS, LOW HEAD, RoHS, M4 X 8	57	
-	2	2	2	2	1-2168083-0	SCR, SKT HD CAP, RoHS, M4 X 10	56	
-	2	2	2	2	5018030-1	NUT, HEX, REG, RoHS, M3	54	
-	2	2	2	2	986965-8	NUT, LOCK, HEX, TORQUE (M4)	53	
-	1	1	1	1	1-5018030-0	NUT, HEX, REG, RoHS, M3.5	52	
-	1	-	1	-	2063961-1	FEED FINGER	51	
-	1	1	1	1	1-1976055-3	STANDOFF, HOLD-DOWN	50	
-	1	2	1	2	18023-9	SCR, SKT HD CAP M4 X 6.0	49	
-	-	1	-	1	2119652-1	FEED CAM, PRE FEED	48	
-	-	1	-	1	2119653-1	FEED CAM, POST FEED	47	
-	1	1	1	1	2119655-5	APPLICATOR BASIC ASSEMBLY, EF	46	
-	1	1	1	1	1803517-1	RAM ASSEMBLY, EF ATLANTIC	44	
-	1	1	1	1	1803602-1	SCR, BHSC, RoHS (M8 X 25)	41	
-	7	7	7	7	1-18028-2	WASHER, FLAT, REG M4	33	
-	2	2	2	2	2168083-9	SCR, SKT HD CAP, RoHS, M4 X 20	31	
-	2	2	2	2	2168083-2	SCR, SKT HD CAP, RoHS, M4 X 8.0	29	
-	1	1	1	1	240639-1	STRIPPER (MACHINING)	27	
-	2	2	2	2	1-2168083-5	SCR, SKT HD CAP, RoHS, M4 X 30	25	
-	1	1	1	1	1-1752371-2	PLATE, STRIP GUIDE	24	
-	1	1	1	1	240825-2	PLATE, STRIP HOLD DOWN	23	
-	2	2	2	2	2-22281-3	SPRING, COMPRESSION	22	
-	1	1	1	1	1803292-4	DRAG	20	
-	2	2	2	2	1901259-6	GUIDE, LOWER STRIP	18	
-	4	4	4	4	1-2079383-1	SCR, BHSC, RoHS (M6 X 12)	17	
-	1	1	1	1	1752360-1	SPACER, HOLD-DOWN	13	
-	1	1	1	1	240644-5	PLATE, REAR SHEAR	11	
-	-	-	-	-	-	-	10	
-	1	1	1	1	690482-4	PLATE, FRONT SHEAR	9	
-	1	2	2	1	1	4-1803001-3	ANVIL, COMBINATION, END FEED	8
-	1	1	1	1	1	1-2217206-0	BLADE, SLUG	7
-	-	-	-	-	-	-	6	
-	1	1	1	1	1	1-240641-2	SPACER	5
-	1	1	1	1	1	238011-2	BLOCK, CRIMPER SPACER	4
-	1	2	2	1	1	4-2119582-8	CRIMPER, INSULATION F PREMIUM	3
-	1	1	1	1	1	1-455888-1	SPACER, CRIMPER	2
-	1	2	2	1	1	2-1633588-2	CRIMPER, WIRE	1
-	77	72	71	2	-1	PART NO	DESCRIPTION	ITEM NO

DIMENSIONS:		TOLERANCES UNLESS OTHERWISE SPECIFIED:		DWG		CHK		APVD		NAME	
mm	0 PLC ±	1 PLC ±	2 PLC ±	3 PLC ±	4 PLC ±	Y. YIN	G. BAILEY	12FEB2014	12FEB2014	12FEB2014	TE Connectivity Harrisburg, PA 17105-3608
MATERIAL		FINISH		WEIGHT		SCALE		SHEET		REV	
						A 00779 ©=2150409		1 OF 4		B	

LOC		DIST		REVISIONS			
A	66	P	LTM	DESCRIPTION	DATE	OWN	APVD
		-	-	SEE SHEET 1	-	-	-

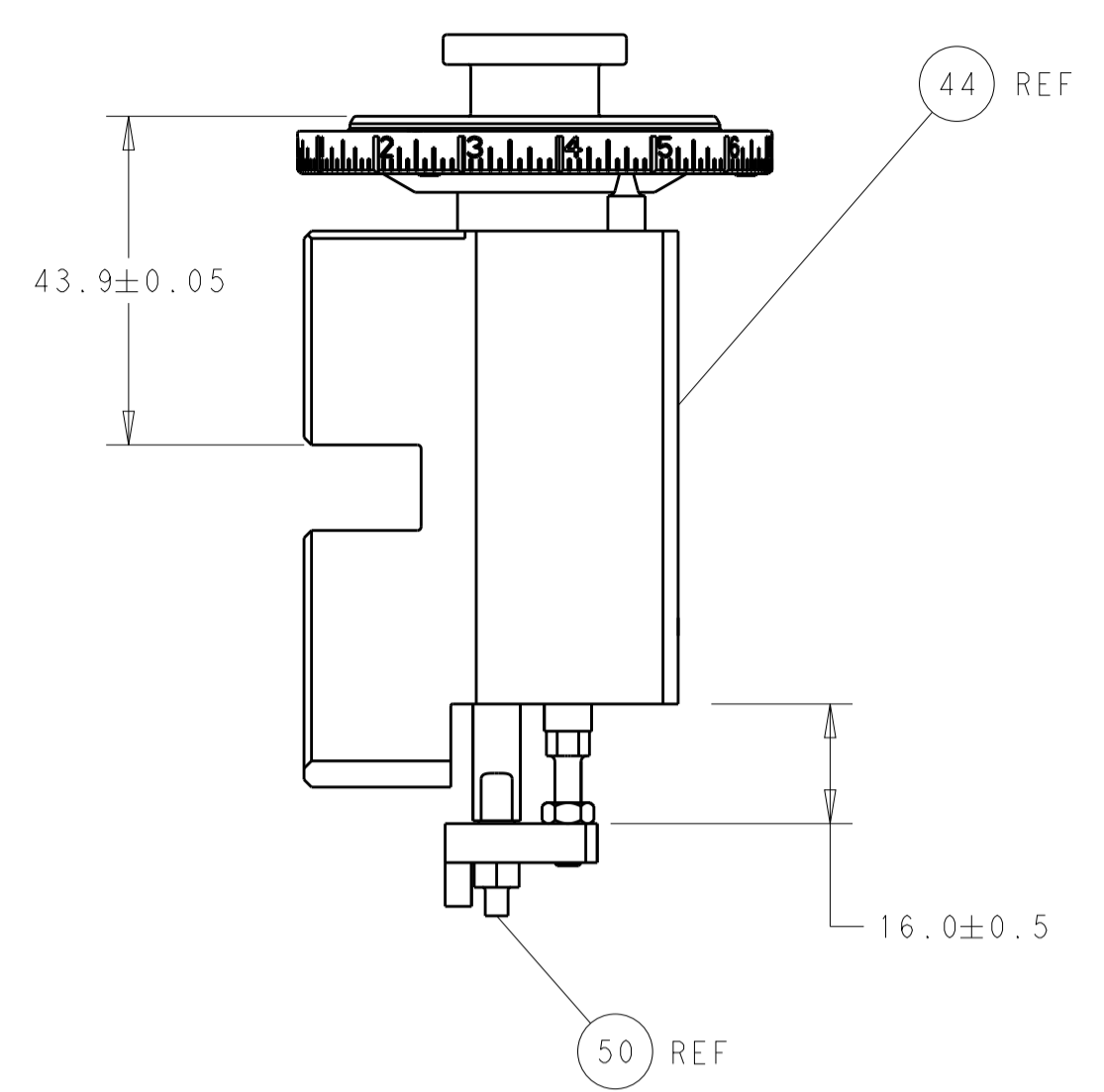

RAM AND HOLDDOWN SET-UP

FEED TYPE
MECHANICAL

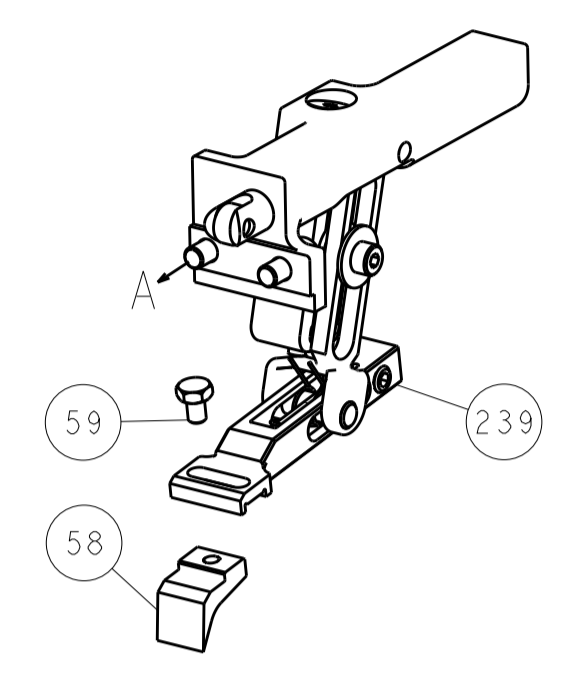

PNEUMATIC

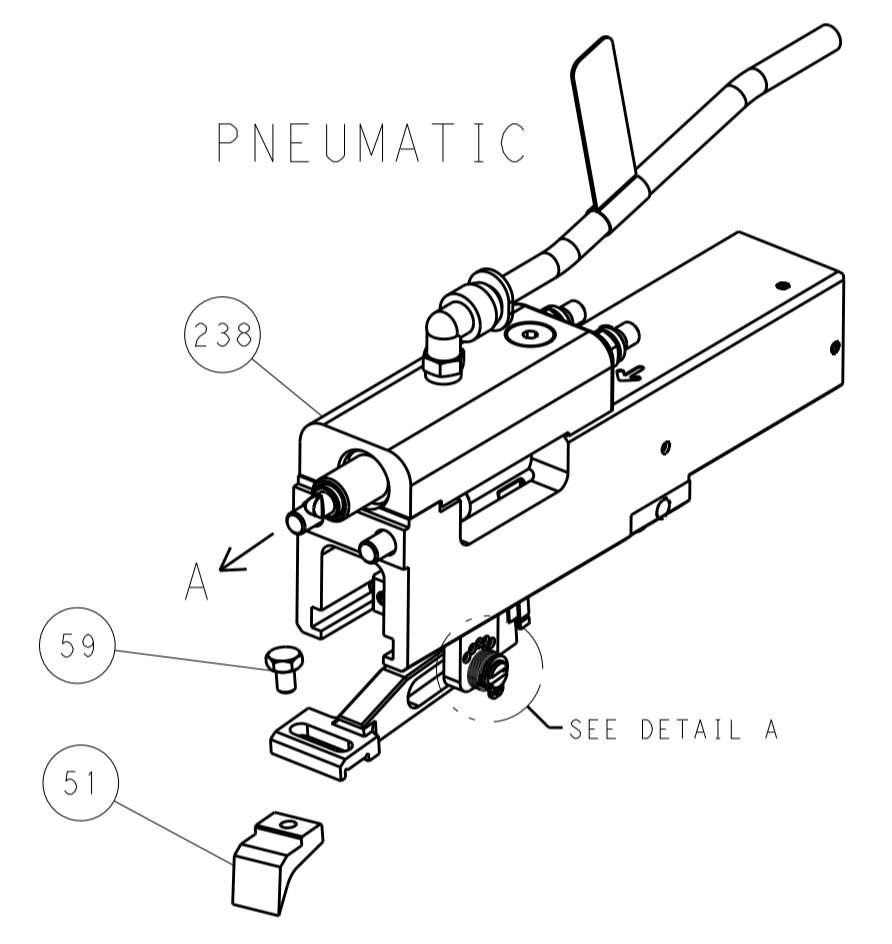

FEED SPRING
SETTING POSITION

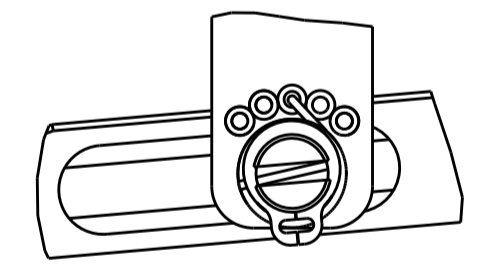

DETAIL A

CAM POSITIONS

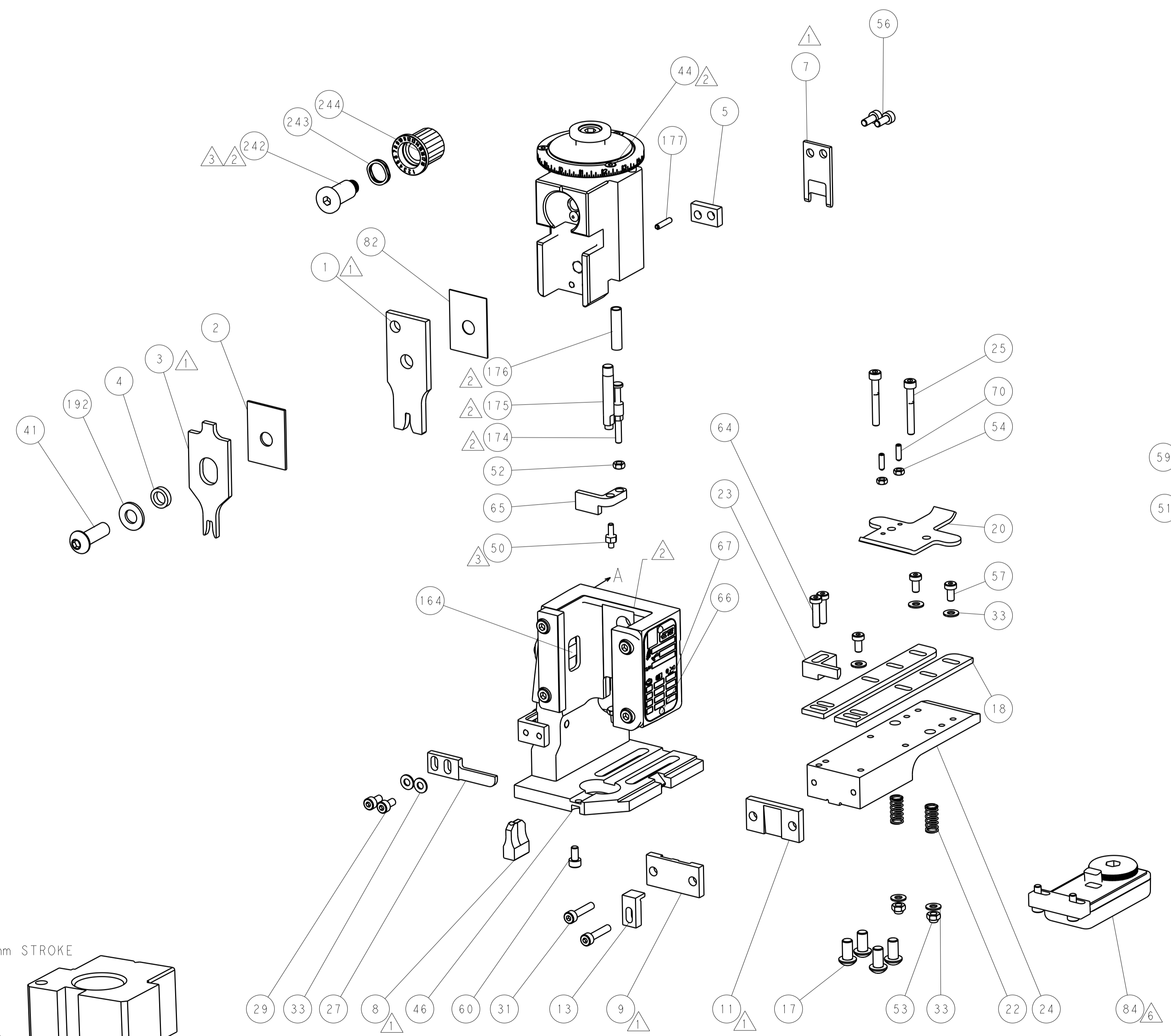
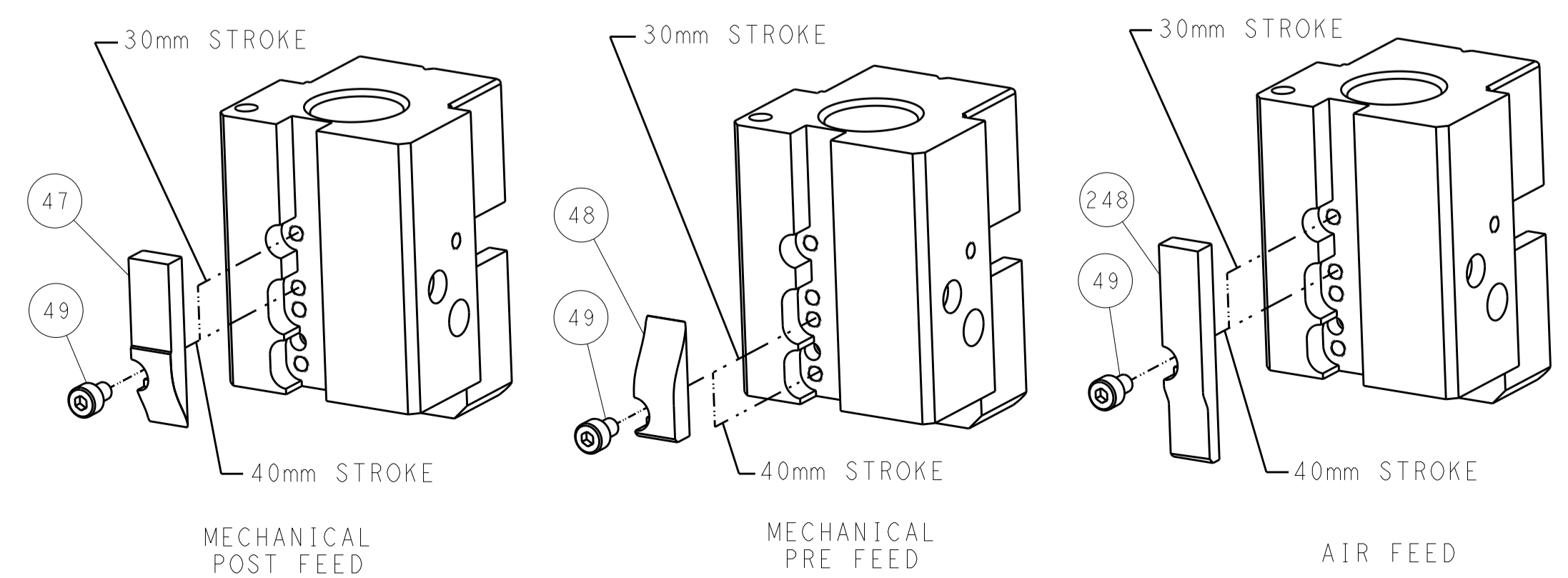

ATLANTIC VERSION
 Shown on sheets 1 of 4 & 2 of 4
 (Pacific version shown on sheets 3 of 4 & 4 of 4)

DIMENSIONS:		TOLERANCES UNLESS OTHERWISE SPECIFIED:		DWN Y. YIN 12FEB2014		TE Connectivity	
mm	0 PLC ±	1 PLC ±	2 PLC ±	3 PLC ±	4 PLC ±	5 PLC ±	Harrisburg, PA 17105-3608
MATERIAL:		FINISH:		APVD G. BAILEY 12FEB2014		NAME Ocean End Feed Applicator	
Customer Accessible Production Drawing		SCALE 1:1		SHEET 2 of 4		REV B	

PART NUMBER	REVISION	DESCRIPTION	FEED TYPE
2-2150409-1	B	FINE CRIMP HEIGHT ADJUST	MECHANICAL
2-2150409-2	B	FINE CRIMP HEIGHT ADJUST	PNEUMATIC
7-2150409-7	A	CRIMP TOOLING KIT	-

PACIFIC VERSION TERMINATOR
 INTERFACE ADAPTER

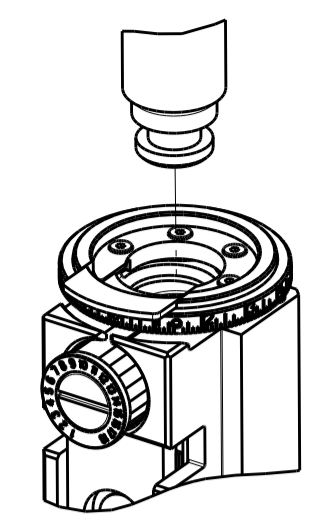

APPLICATOR DATA

CRIMP	SIZE	TYPE
WIRE	2.97 mm (.117)	F
INSUL	4.01 mm (.158)	F

APPLICATOR INSTRUCTIONS
 408-35043

TERMINAL DATA: HATKO TERMINAL HATKO CRIMP SPECIFICATION

TERMINAL NAME: TERMINAL

WIRE STRIP LENGTH	INSULATION DIAMETER RANGE
5.17-5.18 mm (.204-.204 IN)	3.05 mm MAX (.120 IN MAX)

TERMINAL APPLICATION SPECIFICATION HATKO SPEC

TERMINALS APPLIED

TE TERMINAL	HATKO TERMINAL	TE TERMINAL	HATKO TERMINAL
2113425-1	0100104006	2113425-3	0500104006
2113425-2	0300104006		

WIRE SIZE	CRIMP HEIGHT mm [INCH]	CRIMP HEIGHT REFERENCE SETTING
2.50mm2	2.13 +/- 0.02 [.084 +/- .001]	6.7
1.50mm2	1.93 +/- 0.02 [.076 +/- .001]	8.0
1.00mm2	1.85 +/- 0.02 [.073 +/- .001]	8.4

- 1 RECOMMENDED SPARE PARTS
- 2 REFER TO SUPPLIED INSTRUCTION SHEET FOR CLEANING, LUBRICATION AND STORAGE OF APPLICATOR.
- 3 APPLY PART NUMBER 1-23419-5 LOCTITE TO THREADS OF ITEM 50. APPLY PART NUMBER 2-23419-6 LOCTITE TO THREADS OF ITEM 242.
- 4 CRIMP HEIGHT REFERENCE SETTING WAS THE SETTING USED WHEN THE APPLICATOR WAS QUALIFIED AT THE FACTORY. ADJUSTMENT MAY BE NECESSARY WHEN RUNNING APPLICATOR IN THE FIELD.
- 5. UNLESS SPECIFIED OTHERWISE TORQUE VALUES SHALL BE USED PER DOCUMENT, 101-35000.
- 6 TERMINAL LUBRICANT IS RECOMMENDED.

***WARNING**
 ON INSTALLATION, SET WIRE DISC TO CRIMP HEIGHT REFERENCE SETTING FOR LARGEST WIRE SIZE. CRIMP HEIGHT REFERENCE SETTINGS GREATER THAN THE VALUE SHOWN MAY CAUSE DAMAGE TO THE CRIMP TOOLING, REFER TO THE INSTRUCTION SHEET FOR PROPER SETUP AND ADJUSTMENTS.

PACIFIC VERSION
 Shown on sheets 3 of 4 & 4 of 4
 (Atlantic version shown on sheets 1 of 4 & 2 of 4)

LOC	DIST	REV	DATE	BY	APPD
A	66				

REV	DATE	DESCRIPTION	ITEM NO
-	-	SEE SHEET 1	-
-	1 1	2119082-3 CAM, SNAIL, INSULATION ADJUSTMENT	244
-	1 1	2079764-1 WASHER, WAVE SPRING, CREST-TO-CREST	243
-	1 1	2119083-1 RETAINER, INSULATION DIAL	242
-	- 1	2119580-1 MECHANICAL FEED ASSEMBLY	239
-	1 -	2844940-3 AIR FEED MODULE	238
-	1 1	1-18028-0 WASHER, FLAT, REG M8	192
-	4 4	2079383-9 SCR, BHSC, RoHS (M6 X 20)	186
-	1 1	6-993111-6 PIN, SLOTTED SPRING 3.0 X 14.0	177
-	1 1	8-22280-7 SPRING, COMPRESSION	176
-	1 1	1752353-2 GUIDE PIN, HOLDDOWN	175
-	1 1	1901680-2 GUIDE PIN, HOLDDOWN	174
-	REF REF	994970-2 COUNTER, MAGNETIC	164
-	1 -	2119641-2 FEED CAM, AIR FEED	152
-	1 1	2168083-8 SCR, SKT HD CAP, RoHS, M4 X 16	144
-	- 1	2119653-2 FEED CAM, POST FEED	142
-	1 1	2119655-6 APPLICATOR BASIC ASSEMBLY, EF	141
-	1 1	1803518-1 RAM ASSEMBLY, EF PACIFIC	140
-	1 1	2119955-2 ASSY, LUBRICATOR, END FEED	84
-	1 1	455888-4 SPACER, CRIMPER	82
-	1 1	1803607-4 DOCUMENTATION PACKAGE	71
-	2 2	2-18032-2 SCR, SET, FLT PNT, M3 X 10.0	70
-	1 1	2119740-1 TAG, IDENTIFICATION	67
-	2 2	2168078-1 SCREW, DRIVE, RH, RoHS, 2 x .188	66
-	1 1	1901681-5 HOLDDOWN, TERMINAL	65
-	2 2	2168400-8 SHCS, LOW HEAD, RoHS, M4 X 16	64
-	1 1	5-18022-5 SCR, HEX HD CAP, M4 X 6.0	59
-	- 1	2063961-1 FEED FINGER	58
-	3 3	2168400-4 SHCS, LOW HEAD, RoHS, M4 X 8	57
-	2 2	1-2168083-0 SCR, SKT HD CAP, RoHS, M4 X 10	56
-	2 2	5018030-1 NUT, HEX, REG, RoHS, M3	54
-	2 2	986965-8 NUT, LOCK, HEX, TORQUE (M4)	53
-	1 1	1-5018030-0 NUT, HEX, REG, RoHS, M3.5	52
-	1 -	2063961-1 FEED FINGER	51
-	1 1	1-1976055-3 STANDOFF, HOLD-DOWN	50
-	1 2	18023-9 SCR, SKT HD CAP M4 X 6.0	49
-	- 1	2119652-1 FEED CAM, PRE FEED	48
-	1 1	1803602-1 SCR, BHSC, RoHS (M8 X 25)	41
-	7 7	1-18028-2 WASHER, FLAT, REG M4	33
-	2 2	2168083-9 SCR, SKT HD CAP, RoHS, M4 X 20	31
-	2 2	2168083-2 SCR, SKT HD CAP, RoHS, M4 X 8.0	29
-	1 1	240639-1 STRIPPER (MACHINING)	27
-	2 2	1-2168083-5 SCR, SKT HD CAP, RoHS, M4 X 30	25
-	1 1	1-1752371-2 PLATE, STRIP GUIDE	24
-	1 1	240825-2 PLATE, STRIP HOLD DOWN	23
-	2 2	2-22281-3 SPRING, COMPRESSION	22
-	1 1	1803292-4 DRAG	20
-	2 2	1901259-6 GUIDE, LOWER STRIP	18
-	1 1	1752360-1 SPACER, HOLD-DOWN	13
-	1 1	240644-5 PLATE, REAR SHEAR	11
-	- -	-	10
-	1 1	690482-4 PLATE, FRONT SHEAR	9
-	1 1 1	4-1803001-3 ANVIL, COMBINATION, END FEED	8
-	1 1	1-2217206-0 BLADE, SLUG	7
-	- -	-	6
-	1 1	1-240641-2 SPACER	5
-	1 1	238011-2 BLOCK, CRIMPER SPACER	4
-	1 1 1	4-2119582-8 CRIMPER, INSULATION F PREMIUM	3
-	1 1	1-455888-1 SPACER, CRIMPER	2
-	1 1 1	2-1633588-2 CRIMPER, WIRE	1
-	77-22-21	PART NO DESCRIPTION	ITEM NO

DIMENSIONS: mm		TOLERANCES UNLESS OTHERWISE SPECIFIED:		DWG Y. YIN 12FEB2014		CHK G. BAILEY 12FEB2014		APVD H. GUO 12FEB2014		NAME	
0 PLC ±		1 PLC ±		2 PLC ±		3 PLC ±		4 PLC ±		SIZE CAGE CODE DRAWING NO RESTRICTED TO	
MATERIAL		FINISH		WEIGHT		SCALE		SHEET 3 OF 4		REV B	

LOC		DIST		REVISIONS			
A	66	P	LTM	DESCRIPTION	DATE	DMN	APVD
				SEE SHEET 1			

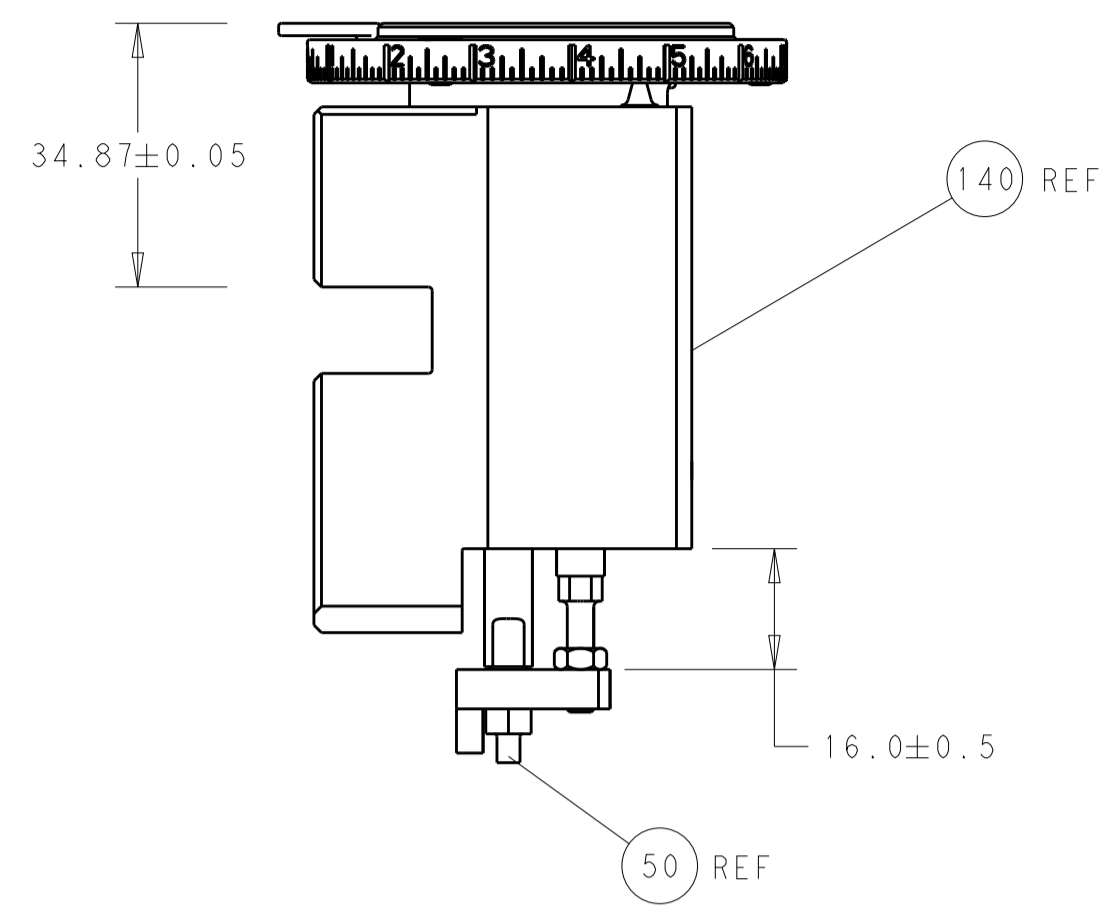

RAM AND HOLDDOWN SET-UP

FEED TYPE
MECHANICAL

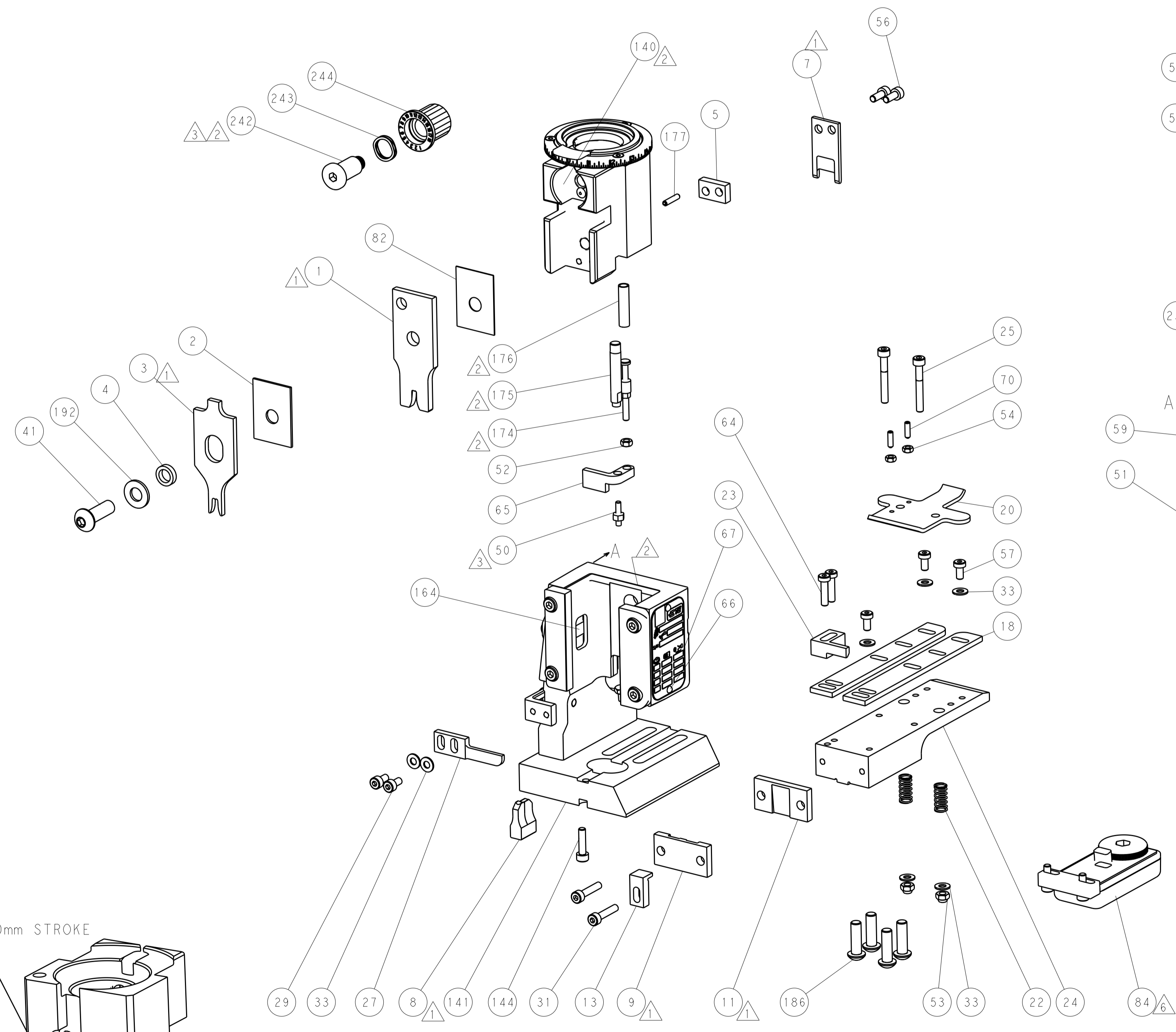
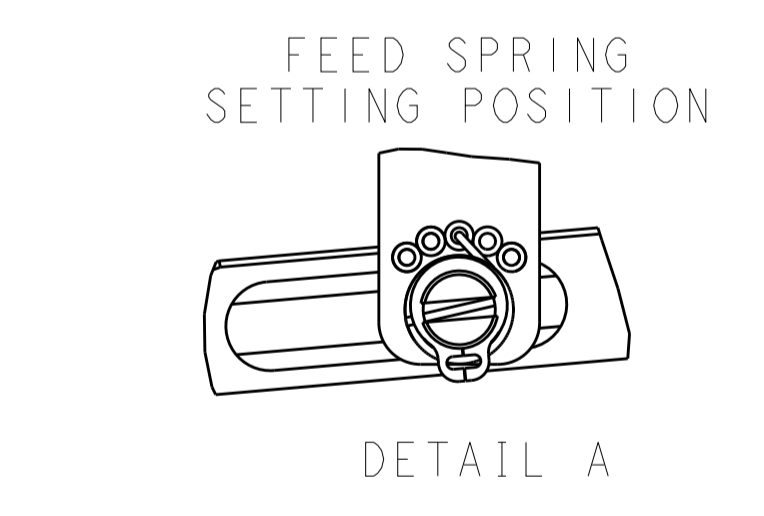
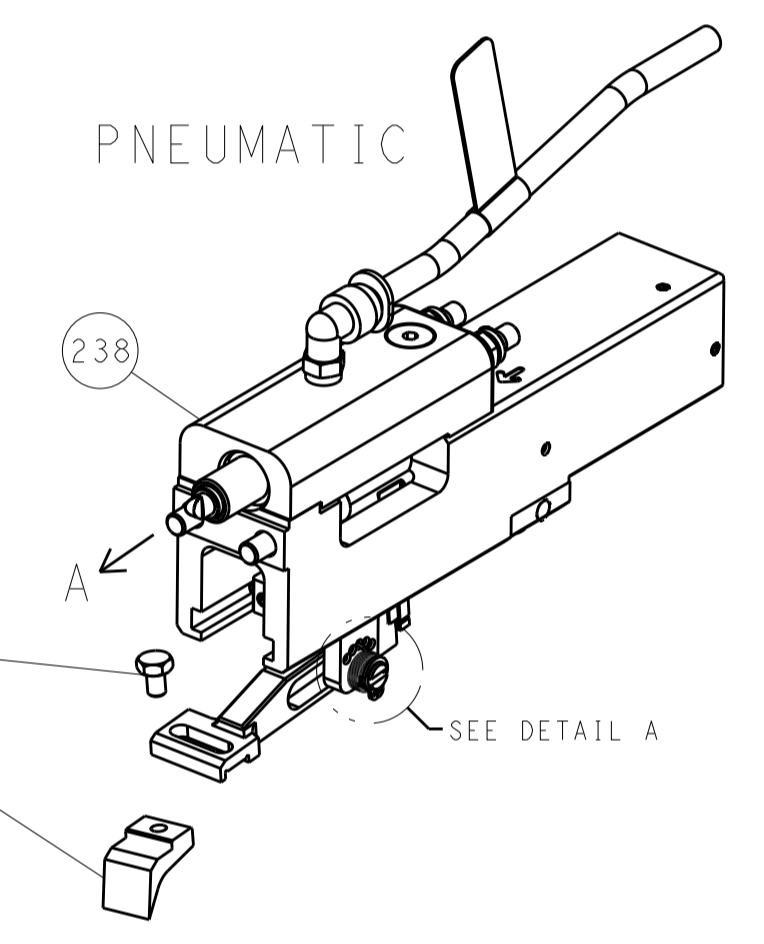
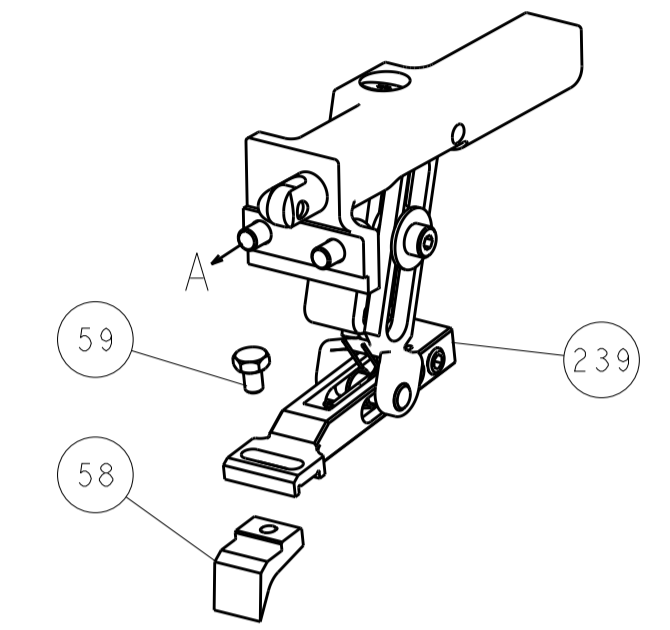

CAM POSITIONS

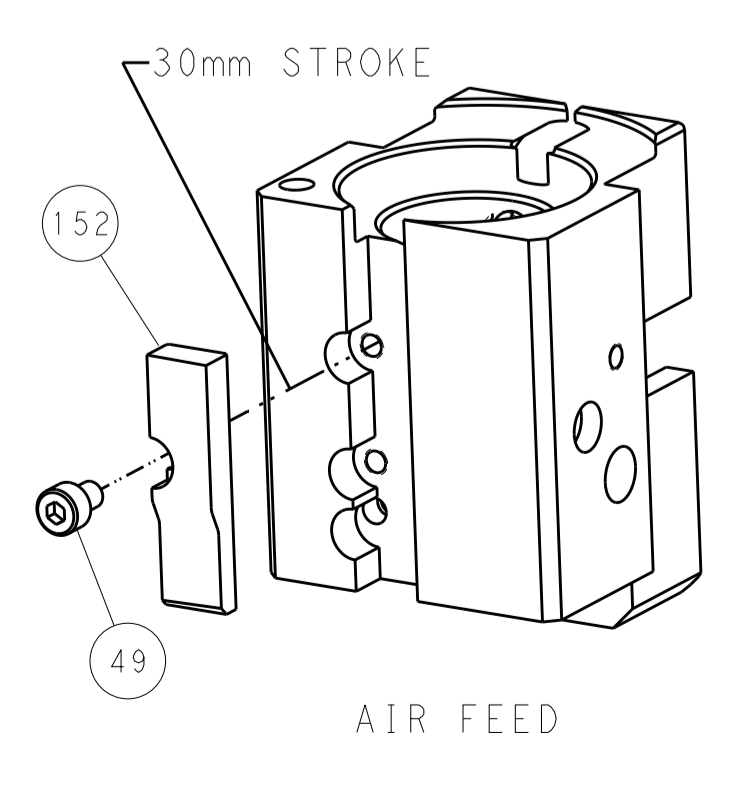
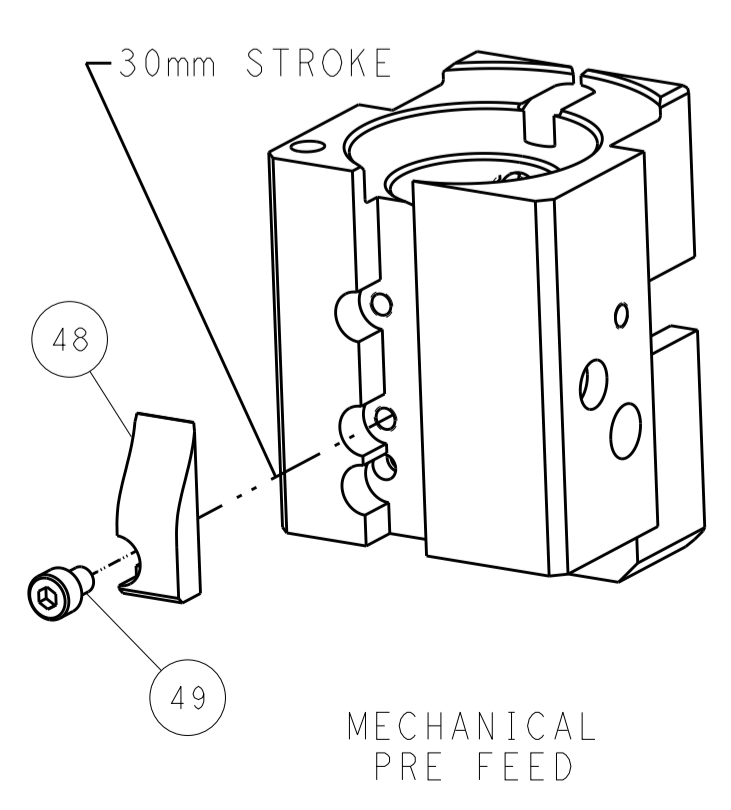
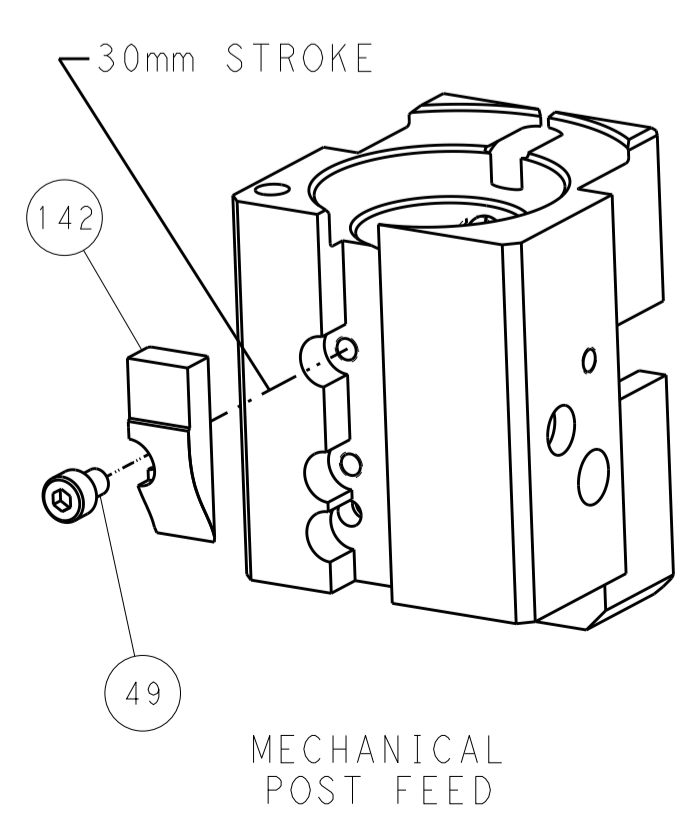

PACIFIC VERSION
 Shown on sheets 3 of 4 & 4 of 4
 (Atlantic version shown on sheets 1 of 4 & 2 of 4)

DIMENSIONS:		TOLERANCES UNLESS OTHERWISE SPECIFIED:		DWG: Y. YIN 12FEB2014		CHK: G. BAILEY 12FEB2014		APVD: H. GUO 12FEB2014		NAME: Ocean End Feed Applier	
mm	0 PLC	±		SIZE	CAGE CODE	DRAWING NO	RESTRICTED TO	STE TE Connectivity Harrisburg, PA 17105-3608			
	1 PLC	±		SCALE	1:1	SHEET 4 OF 4	REV B	Customer Accessible Production Drawing			
	2 PLC	±		A 00779 ©=2150409							
	3 PLC	±									
	4 PLC	±									
	ANGLES	±									
MATERIAL	FINISH										