

THIS DRAWING IS UNPUBLISHED. RELEASED FOR PUBLICATION  
 © COPYRIGHT - By - ALL RIGHTS RESERVED.

LOC	DIST	REVISIONS			
P	LTR	DESCRIPTION	DATE	DWN	APVD
AF	50				
	K2	REVISED PER ECO-11-004820	11MAR11	RK	HMR

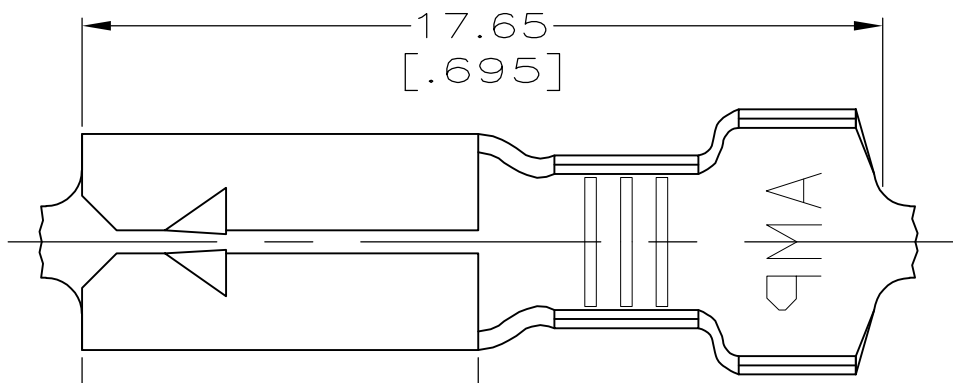

- 1 CONTINUOUS STRIP ON REEL.
- 2 0.002032 [.000080] MIN TIN PL PER ASTM-B545.
- 3 0.00508 [.000200] MIN SILVER PL OVER 0.00254 [.000100] MIN COPPER UNDEPLATE OR 0.00127 [.000050] MIN NICKEL UNDEPLATE.

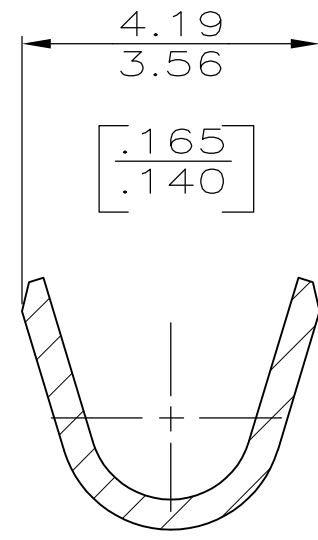
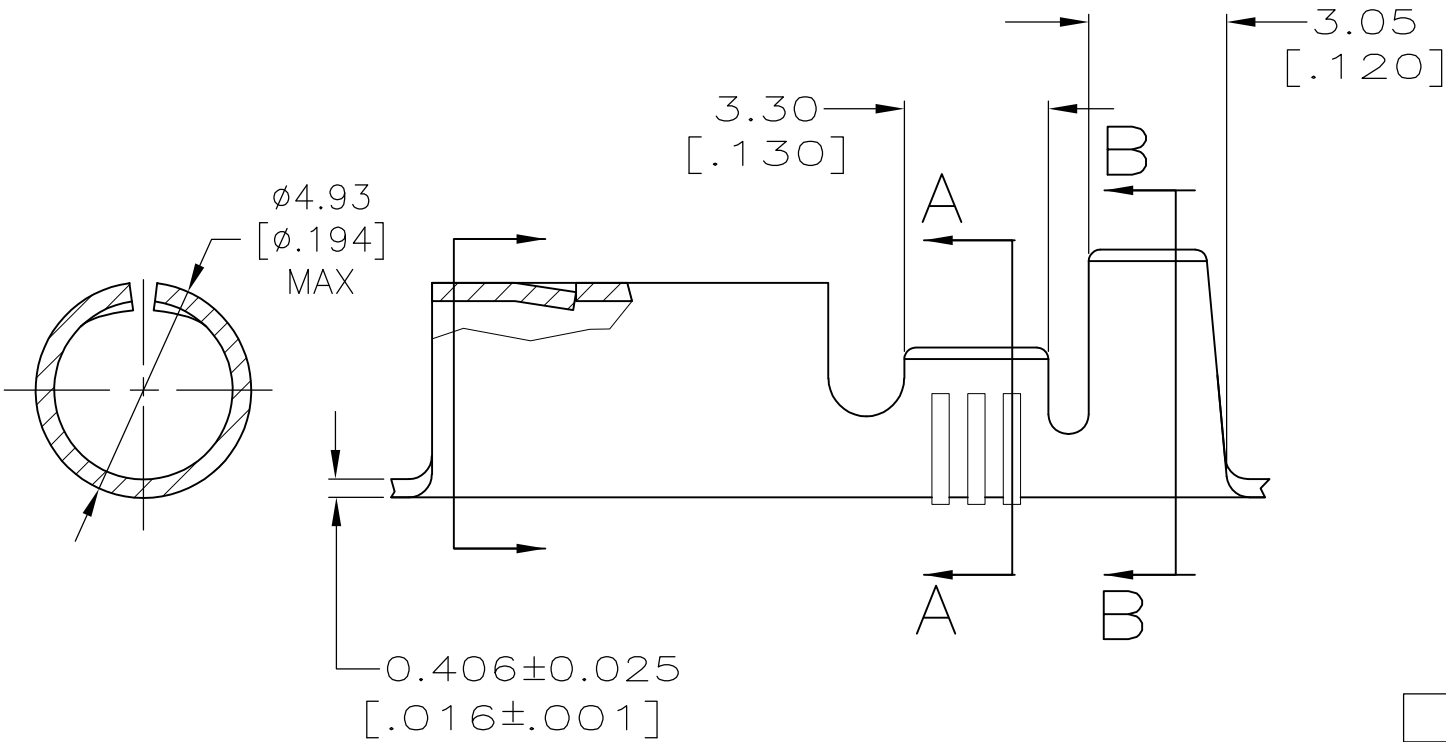

SECTION A-A  
SCALE 10:1

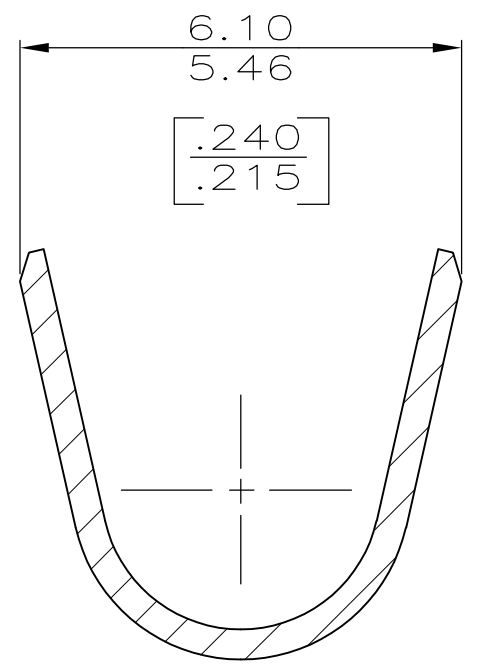

SECTION B-B  
SCALE 10:1

3	3.30-4.44 DIA	[18-14] AWG	42142-4
-	[.130-.175]		42142-2
2			42142-1
FINISH	INSULATION RANGE	WIRE RANGE	PART NO

THIS DRAWING IS A CONTROLLED DOCUMENT.		DWN PHILLIP M FORTNEY 29/AUG/95	<b>STE</b> TE Connectivity	
DIMENSIONS: mm [INCHES]		CHK JEFF R RUTH 29/AUG/95		
TOLERANCES UNLESS OTHERWISE SPECIFIED:		APVD GARY YETTER 29/AUG/95	NAME RECEPTACLE, SHUR PLUG, 3.96 [.156] DIA	
0 PLC ± -		PRODUCT SPEC	SIZE	
1 PLC ± -		APPLICATION SPEC	CAGE CODE	
2 PLC ± 0.25 [.010]		WEIGHT	DRAWING NO	
3 PLC ± -		CUSTOMER DRAWING	A300779	
4 PLC ± -			C-42142	
ANGLES ± -		SCALE	RESTRICTED TO	
FINISH		6:1	-	
4M BRASS		SHEET	1 OF 1	
SEE TABLE		REV	K2	