

THIS DRAWING IS UNPUBLISHED. RELEASED FOR PUBLICATION
 © COPYRIGHT BY TYCO ELECTRONICS CORPORATION. ALL RIGHTS RESERVED.

LOC		DIST		REVISIONS			
P	LTR	DESCRIPTION		DATE	DWN	APVD	
HC	00	A	REV PER ECO 06-002539	07APR06	GB	JH	

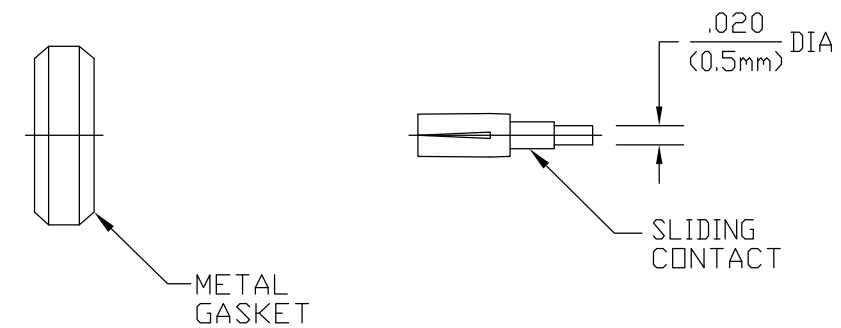
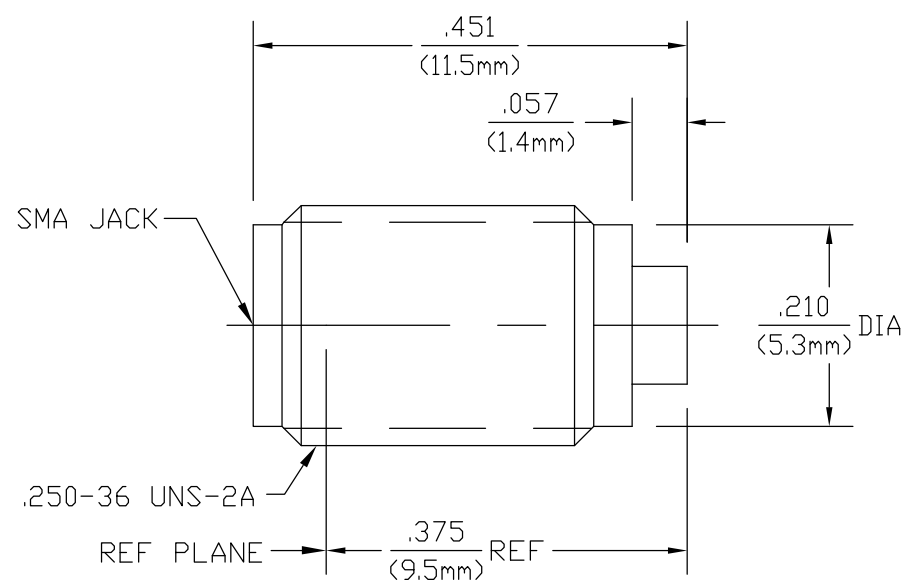
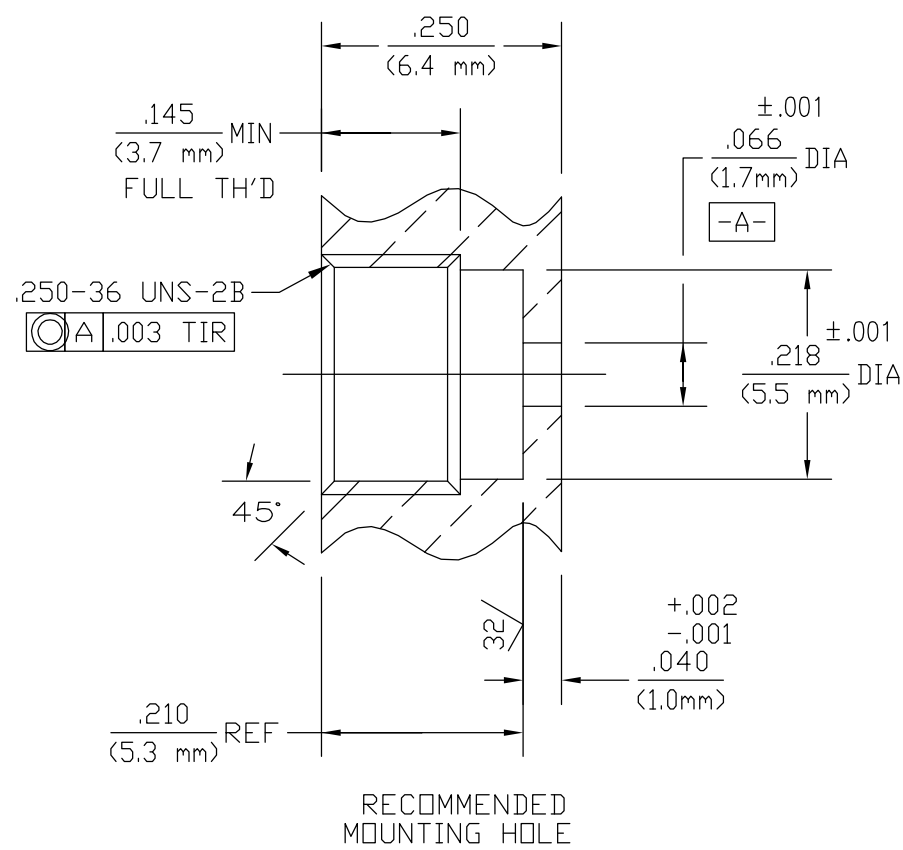

6053252-1
 PART NUMBER

COMPONENT	MATERIAL	FINISH
HOUSING	STAINLESS STEEL PER ASTM-A484 AND ASTM-A582, TYPE 303	PASSIVATE PER ASTM A380
DIELECTRIC	TFE FLUOROCARBON PER ASTM D 1710	N/A
CENTER CONTACT SLIDING CONTACT	BERYLLIUM COPPER PER ASTM B196	GOLD PLATE PER ASTM B 488
CONTACT EXT. BUSHING	IRON-NICKEL-COBALT ALLOY PER MIL-I-23011 CLASS 1 (KOVAR)	GOLD PLATE PER ASTM B 488
HERMETIC SEAL	GLASS BEAD	N/A
METAL GASKET	SAE C12L14	SILVER PLATE PER ASTM B 700

ELECTRICAL	MECHANICAL	ENVIRONMENTAL
Nominal Impedance (Ohms) 50	Interface Dimensions MIL-STD-348A, Fig. 310.2	TEMPERATURE RATING -65°C TO +165°C
Frequency Range (GHz) DC - 18	Mating Characteristics:	Vibration - MIL-STD-202, Method 204, Condition D, 20G's
Volt Rating (VRMS MAX) N/A	Insertion (MAX lbs) 3.0	Shock - MIL-STD-202, Method 107, Condition B
VSWR 1.04 +.009 *f(GHz)	Withdrawal (MIN Oz) 1.0	Thermal Shock MIL-STD-202, Method 107, Condition B
Insertion Loss (dB MAX) .05√f(GHz)	Force To Engage (In-lbs MAX) 2.0	Moisture Resistance - MIL-STD-202, Method 106
RF Leakage (dB MIN) -[100 - f(GHz)]	Force To Disengage (In-lbs MAX) 2.0	Corrosion - MIL-STD-202, Method 101, Condition B, 5% salt spray
Corona, 70,000 Ft (VRMS MIN) 333	Center Contact Captivation	Leak Test Per MIL-STD-202, Method 112, Condition C, Procedure 1 1*10 ⁻⁸ cc/sec
Dielectric Withstanding Voltage (VRMS MIN) 1000 @ sea level	Axial 6.0 lbs	
Contact Resistance (Milliohms MAX)	Radial N/A	
Center Contact 10.0	Weight (Grams) I.B.D.	
Outer Contact 2.0		
RF High Potential (VRMS MIN @ 5 MHz) 1,000 @ sea level		
I.R.(Megohms) 5,000 MIN		

THIS DRAWING IS A CONTROLLED DOCUMENT.		DWN V.MICHAUD 01OCT75	tyco Tyco Electronics Corporation Harrisburg, PA 17105-3608	
DIMENSIONS: INCHES (mm)		CHK -	NAME	
TOLERANCES UNLESS OTHERWISE SPECIFIED:		APVD D.S.S. 02OCT75	SMA HERMETICALLY SEALED ENVIRONMENTALLY DURABLE JACK RECEPTACLE, W/SLIDING CONTACT (2058-5269-02)	
0 PLC ± -		PRODUCT SPEC	SIZE A2	CAGE CODE 00779
1 PLC ± -		APPLICATION SPEC	DRAWING NO C=6053252	RESTRICTED TO
2 PLC ± -		408-4867	SCALE 5:1	SHEET 1 of 1
3 PLC ± .005		WEIGHT -	REV A	
4 PLC ± -		CUSTOMER DRAWING		
ANGLES ± -				
FINISH				
SEE NOTES				