

SERIES 800 SWITCHES

PUSHBUTTON SWITCHES - SUB-MINIATURE

TACT SWITCHES

NAVIGATION SWITCHES

PUSHBUTTON SWITCHES

TOGGLE SWITCHES

ROCKER SWITCHES

SLIDE SWITCHES

SNAP-ACTION SWITCHES

DIP SWITCHES

KEYLOCK SWITCHES

ROTARY SWITCHES

DETECTOR SWITCHES

CAP OPTIONS



FEATURES & BENEFITS

- ▶ Subminiature design
- ▶ Butt contact design
- ▶ Snap-in panel mount option

APPLICATIONS/MARKETS

- ▶ Telecommunications
- ▶ Networking
- ▶ Computers/servers
- ▶ Performance audio
- ▶ Instrumentation
- ▶ Low power on/off designs
- ▶ External hard drives and modems

SPECIFICATIONS

Contact Rating:	1A @ 250 VAC 3A @ 120 VAC or 28 VDC
Life Expectancy:	50,000 cycles typical
Contact Resistance:	10mΩ max. typical @ 2-4 VDC 100mA for both silver and gold plated contacts
Insulation Resistance:	1,000MΩ min.
Dielectric Strength:	1,000 V rms @ sea level
Actuation Force:	200 ± 50 gf
Operating Temperature:	-30°C to +85°C

MATERIALS

Case:	DAP
Plunger:	Glass filled nylon or glass filled polyester
Bushing:	Nickel plated brass
Housing:	Stainless steel
Contacts:	Silver or Gold plated copper alloy

HOW TO ORDER

SERIES	MODEL NO.	BUSHING	TERMINATION	CONTACT MATERIAL	SEAL	HARDWARE	CAP	CAP COLOR
800	SP9 SP8	B5 B6 B7 B8* B9* B10	M1 M2 M6 M61 M7 VS2	Q = Silver R = Gold	E = Epoxy Sealed at Base of Terminal	H = Hardware	See Cap Options	

Example Ordering Number
800-SP9-B5-M1-Q-E-H

*Note: C2 cap not available on B8 or B9 bushing.

Specifications subject to change without notice.

BUSHING OPTIONS

B5 THD

B6 NON-THD

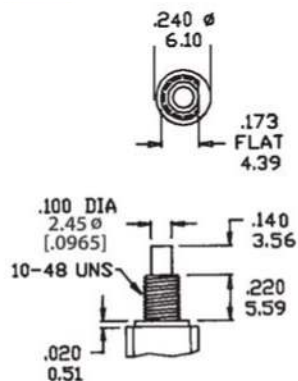

B7 NON-THD

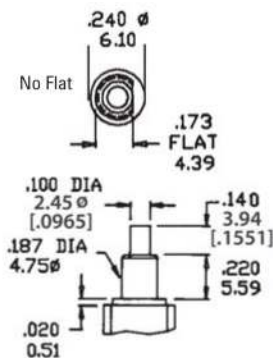

B8 NON-THD

B9 THD

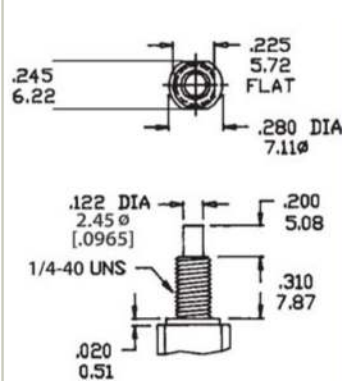

B10 NON-THD

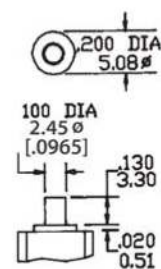

M1

SPST



Model No.	Type	
SP-9	OFF	(ON)
() = Momentary		

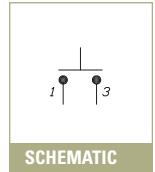
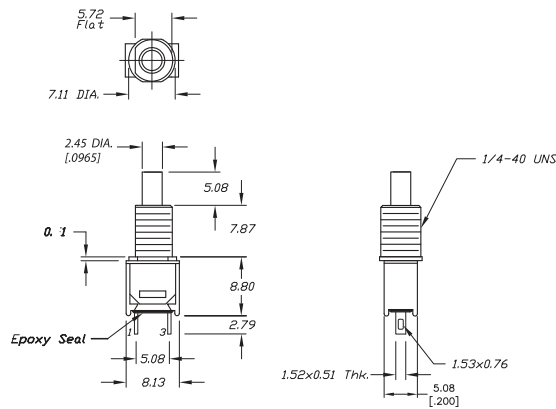

M1

SPDT



Model No.	Type	
SP-8	ON	(ON)
Term. Comm	2-1	2-3
() = Momentary		

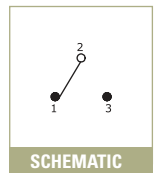
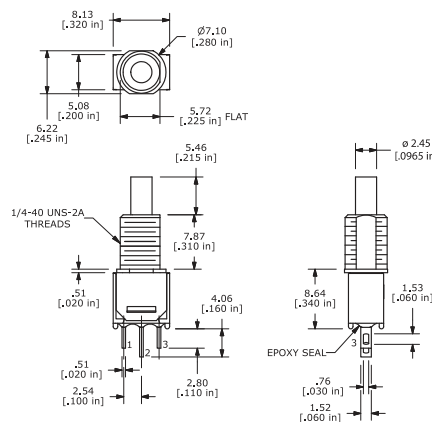

M2

SPST

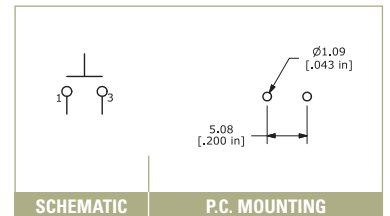
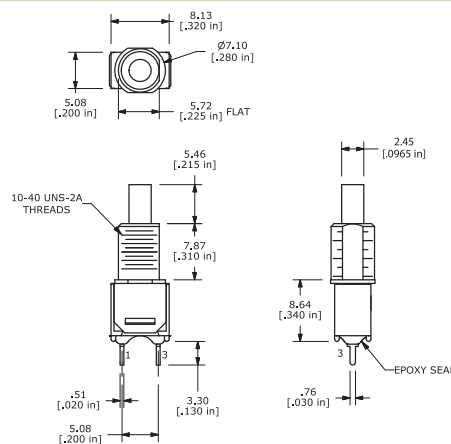

M2

SPDT

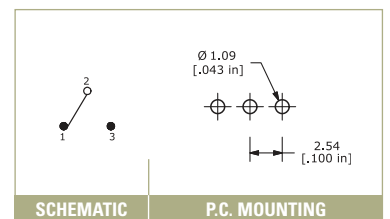
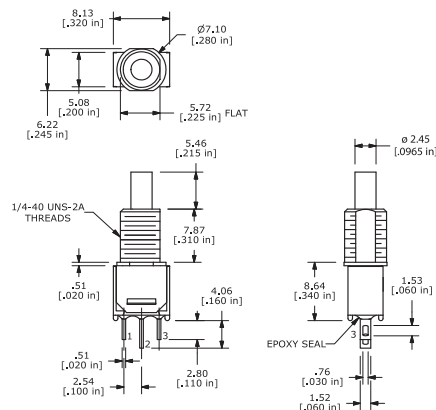

SERIES 800 SWITCHES

PUSHBUTTON SWITCHES - SUB-MINIATURE

TACT
SWITCHES

NAVIGATION
SWITCHES

PUSHBUTTON
SWITCHES

TOGGLE
SWITCHES

ROCKER
SWITCHES

SLIDE
SWITCHES

SNAP-ACTION
SWITCHES

DIP
SWITCHES

KEYLOCK
SWITCHES

ROTARY
SWITCHES

DETECTOR
SWITCHES

CAP
OPTIONS

M6

SPST

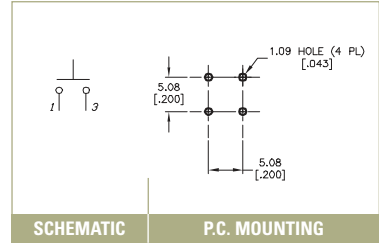
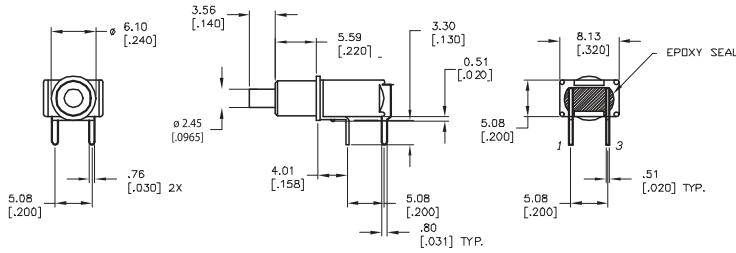

SCHEMATIC

P.C. MOUNTING

M6

SPDT

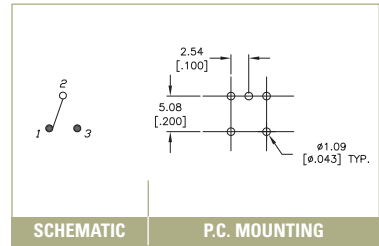
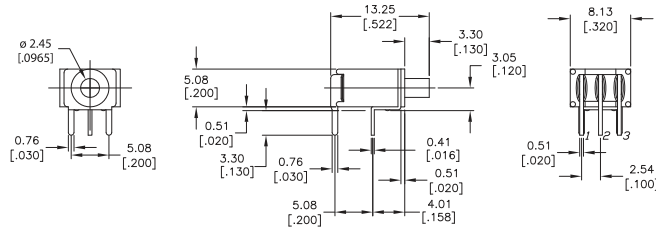

SCHEMATIC

P.C. MOUNTING

M61

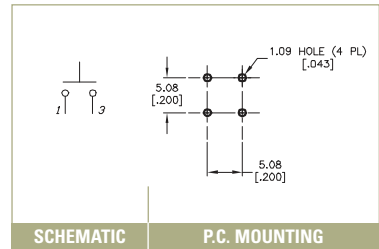
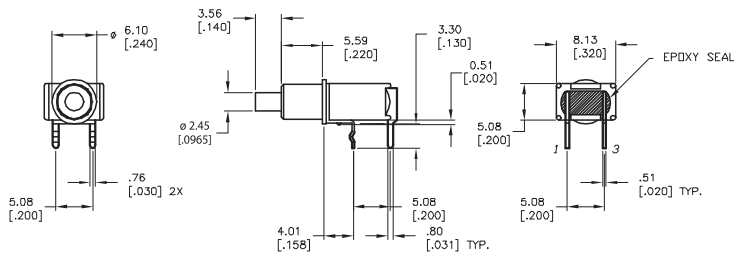

SCHEMATIC

P.C. MOUNTING



M7

SPST

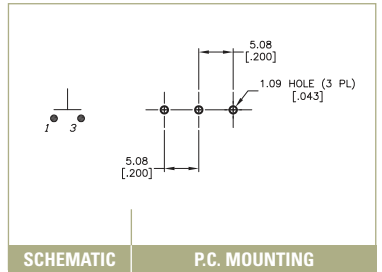
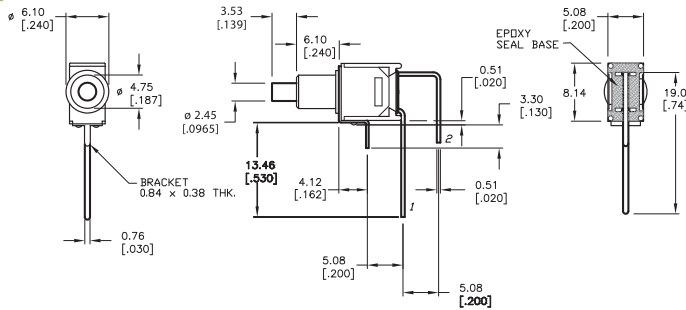

SCHEMATIC

P.C. MOUNTING

M7

SPDT

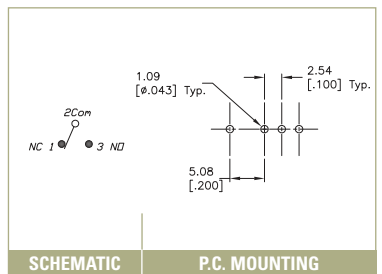
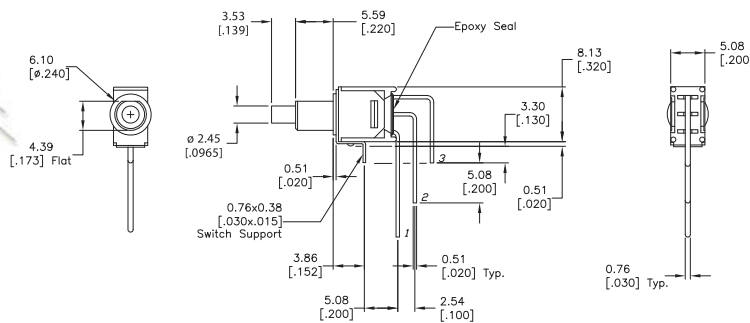

SCHEMATIC

P.C. MOUNTING

VS2

SPST

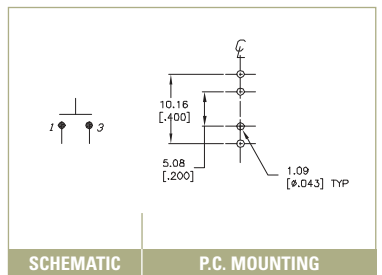
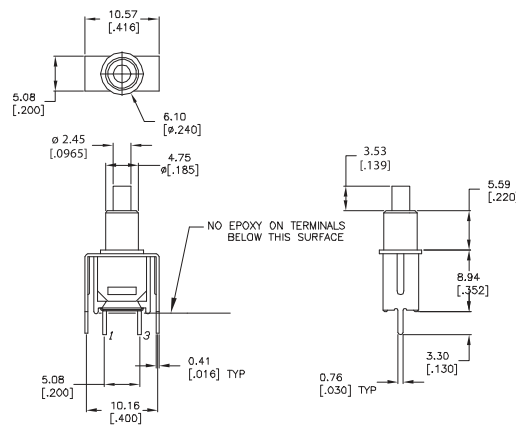

SCHEMATIC

P.C. MOUNTING

VS2

SPDT

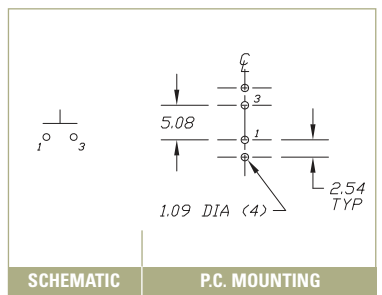
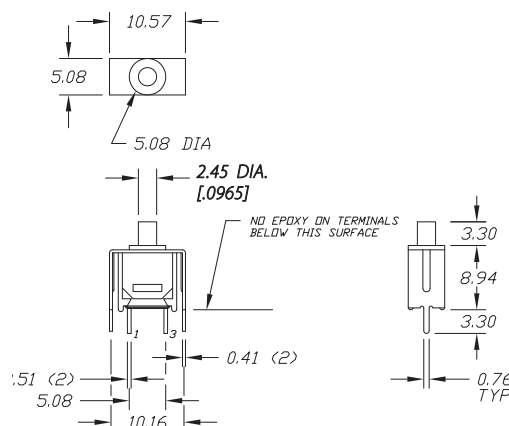

SCHEMATIC

P.C. MOUNTING

SERIES 800 SWITCHES

PUSHBUTTON SWITCHES - SUB-MINIATURE PANEL MOUNT



HOW TO ORDER

SERIES
800

MODEL NO.
SP9
DP8

TERMINATION
M1

CONTACT MATERIAL
Q = Silver
R = Gold

SEAL
E

E = Epoxy
Sealed at
Base of
Terminal

CAP
OP1

CAP COLOR
BLK = Black
RED = Red
WHT = White

FRAME COLOR
BLK = Black
RED = Red
WHT = White



Example Ordering Number

800-SP9-M1-Q-E-OP1-BLK-BLK

Specifications subject to change without notice.

OP1

PANEL MOUNT

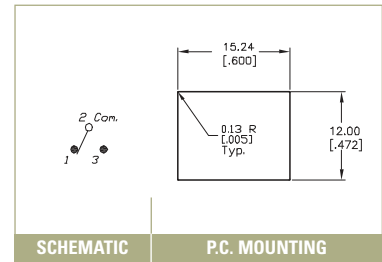
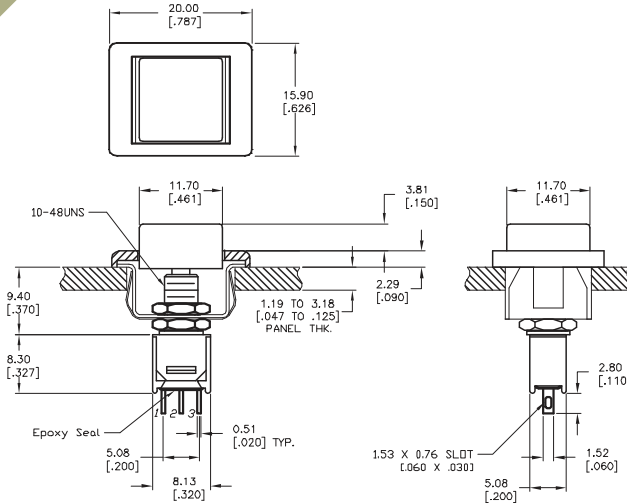

CONTACT MATERIAL OPTIONS

Q

Fixed Terminal:	Silver plated copper alloy
Moving Contact:	Silver plated copper alloy
Rating:	3 AMPS @ 120 VAC; 1 AMP @ 250VAC

R

Fixed Terminal:	Copper alloy with gold plate over nickel plate
Moving Contact:	Copper alloy with gold plate over nickel plate
Rating:	0.4 VA max. @ 20 VAC or DC max.