



MC68HC908AS32A

Advance Information

*M68HC08
Microcontrollers*

*MC68HC908AS32A/D
Rev. 0, 5/2002*

WWW.MOTOROLA.COM/SEMICONDUCTORS

MC68HC908AS32A

Advance Information — Rev 0.0

Motorola reserves the right to make changes without further notice to any products herein. Motorola makes no warranty, representation or guarantee regarding the suitability of its products for any particular purpose, nor does Motorola assume any liability arising out of the application or use of any product or circuit, and specifically disclaims any and all liability, including without limitation consequential or incidental damages. "Typical" parameters which may be provided in Motorola data sheets and/or specifications can and do vary in different applications and actual performance may vary over time. All operating parameters, including "Typicals" must be validated for each customer application by customer's technical experts. Motorola does not convey any license under its patent rights nor the rights of others. Motorola products are not designed, intended, or authorized for use as components in systems intended for surgical implant into the body, or other applications intended to support or sustain life, or for any other application in which the failure of the Motorola product could create a situation where personal injury or death may occur. Should Buyer purchase or use Motorola products for any such unintended or unauthorized application, Buyer shall indemnify and hold Motorola and its officers, employees, subsidiaries, affiliates, and distributors harmless against all claims, costs, damages, and expenses, and reasonable attorney fees arising out of, directly or indirectly, any claim of personal injury or death associated with such unintended or unauthorized use, even if such claim alleges that Motorola was negligent regarding the design or manufacture of the part. Motorola, Inc. is an Equal Opportunity/Affirmative Action Employer.



List of Paragraphs

List of Paragraphs	5
Table of Contents	7
List of Figures	17
List of Tables	23
Section 1. General Description	25
Section 2. Memory Map	37
Section 3. RAM	49
Section 4. FLASH Memory	51
Section 5. EEPROM Memory	63
Section 6. Central Processor Unit (CPU)	83
Section 7. System Integration Module (SIM)	101
Section 8. Clock Generator Module (CGM)	123
Section 9. Configuration Register (CONFIG-1)	151
Section 10. Configuration Register (CONFIG-2)	155
Section 11. Break Module (BRK)	157
Section 12. Monitor ROM (MON)	163
Section 13. Computer Operating Properly (COP)	175
Section 14. Low Voltage Inhibit (LVI)	181
Section 15. External Interrupt Module (IRQ)	187
Section 16. Serial Communications Interface (SCI)	195

List of Paragraphs

Section 17. Serial Peripheral Interface (SPI)	235
Section 18. Timer Interface Module B (TIMB)	267
Section 19. Programmable Interrupt Timer (PIT)	293
Section 20. Input/Output Ports	303
Section 21. Keyboard Module (KBD)	323
Section 22. Timer Interface Module A (TIMA)	331
Section 23. Analog-to-Digital Converter (ADC)	361
Section 24. Byte Data Link Controller (BDLC)	373
Section 25. Electrical Specification	419
Glossary	435

Table of Contents

List of Paragraphs

Table of Contents

List of Figures

List of Tables

Section 1. General Description

1.1	Contents	25
1.2	Introduction	26
1.3	Features	26
1.4	MCU Block Diagram	27
1.5	Pin Assignments	29
1.6	Ordering Information	36

Section 2. Memory Map

2.1	Contents	37
2.2	Introduction	37
2.3	I/O Section	41
2.4	Additional Status and Control Registers	45
2.5	Vector Addresses and Priority	46

Section 3. RAM

3.1	Contents	49
3.2	Introduction	49
3.3	Functional Description	49

Section 4. FLASH Memory

4.1	Contents	51
4.2	Introduction	51
4.3	Functional Description	52
4.4	FLASH Control and Block Protect Registers	52
4.5	FLASH Block Protection	56
4.6	FLASH Mass Erase Operation	57
4.7	FLASH Page Erase Operation	58
4.8	FLASH Program Operation	59
4.9	Low-Power Modes	62

Section 5. EEPROM Memory

5.1	Contents	63
5.2	Introduction	64
5.3	Features	64
5.4	EEPROM Register Summary	65
5.5	Functional Description	66
5.6	EEPROM Register Descriptions	73
5.7	Low-Power Modes	81

Section 6. Central Processor Unit (CPU)

6.1	Contents	83
6.2	Introduction	83
6.3	Features	84
6.4	CPU registers	84
6.5	Arithmetic/logic unit (ALU)	89
6.6	Low-power modes	90
6.7	CPU during break interrupts	90
6.8	Instruction Set Summary	91
6.9	Opcode Map	99

Section 7. System Integration Module (SIM)

7.1	Contents	101
7.2	Introduction	102
7.3	SIM Bus Clock Control and Generation	104
7.4	Reset and System Initialization	106
7.5	SIM Counter	110
7.6	Program Exception Control	111
7.7	Low-Power Modes	116
7.8	SIM Registers	119

Section 8. Clock Generator Module (CGM)

8.1	Contents	123
8.2	Introduction	124
8.3	Features	124
8.4	Functional Description	125
8.5	I/O Signals	135

8.6	CGM Registers	137
8.7	Interrupts	143
8.8	Low-Power Modes	143
8.9	CGM During Break Interrupts	144
8.10	Acquisition/Lock Time Specifications	144

Section 9. Configuration Register (CONFIG-1)

9.1	Contents	151
9.2	Introduction	151
9.3	Functional Description	151

Section 10. Configuration Register (CONFIG-2)

10.1	Contents	155
10.2	Introduction	155
10.3	Functional Description	155

Section 11. Break Module (BRK)

11.1	Contents	157
11.2	Introduction	157
11.3	Features	157
11.4	Functional Description	158
11.5	Low-Power Modes	160
11.6	Break Module Registers	161

Section 12. Monitor ROM (MON)

12.1	Contents	163
12.2	Introduction	163
12.3	Features	163

12.4	Functional Description	164
------	------------------------------	-----

Section 13. Computer Operating Properly (COP)

13.1	Contents	175
13.2	Introduction	175
13.3	Functional Description	176
13.4	I/O Signals	177
13.5	COP Control Register	179
13.6	Interrupts	179
13.7	Monitor Mode	179
13.8	Low-Power Modes	179
13.9	COP Module During Break Interrupts	180

Section 14. Low Voltage Inhibit (LVI)

14.1	Contents	181
14.2	Introduction	181
14.3	Features	181
14.4	Functional Description	182
14.5	LVI Status Register	184
14.6	LVI Interrupts	185
14.7	Low-Power Modes	185

Section 15. External Interrupt Module (IRQ)

15.1	Contents	187
15.2	Introduction	187
15.3	Features	187
15.4	Functional Description	188

15.5	$\overline{\text{IRQ}}$ Pin	191
15.6	IRQ Module During Break Interrupts	192
15.7	IRQ Status and Control Register	192

Section 16. Serial Communications Interface (SCI)

16.1	Contents	195
16.2	Introduction	196
16.3	Features	196
16.4	Pin Name Conventions	197
16.5	Functional Description	197
16.6	Low-Power Modes	215
16.7	SCI During Break Module Interrupts	216
16.8	I/O Signals	216
16.9	I/O Registers	217

Section 17. Serial Peripheral Interface (SPI)

17.1	Contents	235
17.2	Introduction	236
17.3	Features	236
17.4	Pin Name and Register Name Conventions	237
17.5	Functional Description	238
17.6	Transmission Formats	242
17.7	Error Conditions	247
17.8	Interrupts	251
17.9	Queuing Transmission Data	252
17.10	Resetting the SPI	254
17.11	Low-Power Modes	255

17.12	SPI During Break Interrupts	255
17.13	I/O Signals	256
17.14	I/O Registers.	259

Section 18. Timer Interface Module B (TIMB)

18.1	Contents	267
18.2	Introduction	268
18.3	Features	268
18.4	Functional Description	271
18.5	Interrupts.	278
18.6	Low-Power Modes	279
18.7	TIMB During Break Interrupts.	279
18.8	I/O Signals	280
18.9	I/O Registers.	281

Section 19. Programmable Interrupt Timer (PIT)

19.1	Contents	293
19.2	Introduction	293
19.3	Features	294
19.4	Functional Description	294
19.5	PIT Counter Prescaler	296
19.6	Low-Power Modes	296
19.7	PIT During Break Interrupts	297
19.8	I/O Registers.	297

Section 20. Input/Output Ports

20.1	Contents	303
20.2	Introduction	304
20.3	Port A	305
20.4	Port B	307
20.5	Port C	310
20.6	Port D	313
20.7	Port E	316
20.8	Port F	320

Section 21. Keyboard Module (KBD)

21.1	Contents	323
21.2	Introduction	323
21.3	Features	324
21.4	Functional Description	324
21.5	Keyboard Initialization	327
21.6	Low-Power Modes	328
21.7	Keyboard Module During Break Interrupts	328
21.8	I/O Registers	329

Section 22. Timer Interface Module A (TIMA)

22.1	Contents	331
22.2	Introduction	332
22.3	Features	332
22.4	Functional Description	335
22.5	Interrupts	344
22.6	Low-Power Modes	345

22.7	TIMA During Break Interrupts	345
22.8	I/O Signals	346
22.9	I/O Registers	347

Section 23. Analog-to-Digital Converter (ADC)

23.1	Contents	361
23.2	Introduction	362
23.3	Features	362
23.4	Functional Description	362
23.5	Interrupts	365
23.6	Low-Power Modes	365
23.7	I/O Signals	366
23.8	I/O Registers	367

Section 24. Byte Data Link Controller (BDLC)

24.1	Contents	373
24.2	Introduction	374
24.3	Features	374
24.4	Functional Description	375
24.5	BDLC MUX Interface	380
24.6	BDLC Protocol Handler	396
24.7	BDLC CPU Interface	402
24.8	Low-Power Modes	417

Section 25. Electrical Specification

25.1	Contents	419
25.2	Electrical Specifications	420
25.3	Mechanical Specifications	434

Glossary

List of Figures

Figure	Title	Page
1-1	MCU Block Diagram for the MC68HC908AS32A (52-pin PLCC)	28
1-2	MC68HC908AS32A (52-Pin PLCC)	29
1-3	Power supply bypassing	30
2-1	Memory Map (Continued)	40
2-2	I/O Data, Status and Control Registers	41
2-3	Additional Status and Control Registers	45
4-1	FLASH Control Register (FLCR)	53
4-2	FLASH Block Protect Register (FLBPR)	54
4-3	FLASH Block Protect Start Address	54
4-4	FLASH Programming Algorithm Flowchart	61
5-1	EEPROM Register Summary	65
5-2	EEPROM Control Register (EECR)	73
5-3	EEPROM Array Configuration Register (EEACR)	75
5-4	EEPROM Nonvolatile Register (EENVR)	77
5-5	EEDIV Divider High Register (EEDIVH)	78
5-6	EEDIV Divider Low Register (EEDIVL)	78
5-7	EEPROM Divider Non-Volatile Register High (EEDIVHNVR)	80
5-8	EEPROM Divider Non-Volatile Register Low (EEDIVLNVR)	80
6-1	CPU registers	84
6-2	Accumulator (A)	85
6-3	Index register (H:X)	85
6-4	Stack pointer (SP)	86
6-5	Program counter (PC)	87
6-6	Condition code register (CCR)	87
7-1	SIM Block Diagram	103
7-2	SIM I/O Register Summary	103
7-3	CGM Clock Signals	105
7-4	External Reset Timing	107

List of Figures

7-5	Internal Reset Timing	107
7-6	Sources of Internal Reset	108
7-7	POR Recovery	109
7-8	Interrupt Entry	112
7-9	Interrupt Processing	113
7-10	Interrupt Recovery	114
7-11	Interrupt Recognition Example	115
7-12	Wait Mode Entry Timing	117
7-13	Wait Recovery from Interrupt or Break	117
7-14	Wait Recovery from Internal Reset	118
7-15	Stop Mode Entry Timing	119
7-16	Stop Mode Recovery from Interrupt or Break	119
7-17	SIM Break Status Register (SBSR)	120
7-18	SIM Reset Status Register (SRSR)	121
7-19	SIM Break Flag Control Register (SBFCR)	122
8-1	CGM Block Diagram	126
8-2	I/O Register Summary	127
8-3	CGM External Connections	135
8-4	PLL Control Register (PCTL)	137
8-5	PLL Bandwidth Control Register (PBWC)	139
8-6	PLL Programming Register (PPG)	141
9-1	Configuration Register (CONFIG-1)	152
10-1	Configuration Register (CONFIG-2)	155
11-1	Break Module Block Diagram	158
11-2	I/O Register Summary	159
11-3	Break Status and Control Register (BSCR)	161
11-4	Break Address Registers (BRKH and BRKL)	162
12-1	Monitor Mode Circuit	165
12-2	Monitor Data Format	167
12-3	Sample Monitor Waveforms	167
12-4	Read Transaction	168
12-5	Break Transaction	168
12-6	Monitor Mode Entry Timing	173
13-1	COP Block Diagram	177
13-2	COP Control Register (COPCTL)	179
14-1	LVI Module Block Diagram	183
14-2	LVI I/O Register Summary	183
14-3	LVI Status Register (LVISR)	184

15-1	IRQ Block Diagram	188
15-2	IRQ Interrupt Flowchart	190
15-3	IRQ Status and Control Register (ISCR)	192
16-1	SCI Module Block Diagram	198
16-2	SCI I/O Register Summary	199
16-3	SCI Data Formats	200
16-4	SCI Transmitter	202
16-5	SCI Transmitter I/O Register Summary	203
16-6	SCI Receiver Block Diagram	206
16-7	SCI I/O Receiver Register Summary	207
16-8	Receiver Data Sampling	209
16-9	Slow Data	211
16-10	Fast Data	212
16-11	SCI Control Register 1 (SCC1)	218
16-12	SCI Control Register 2 (SCC2)	221
16-13	SCI Control Register 3 (SCC3)	224
16-14	SCI Status Register 1 (SCS1)	226
16-15	Flag Clearing Sequence	228
16-16	SCI Status Register 2 (SCS2)	230
16-17	SCI Data Register (SCDR)	231
16-18	SCI Baud Rate Register (SCBR)	231
17-1	SPI Module Block Diagram	239
17-2	Full-Duplex Master-Slave Connections	240
17-3	Transmission Format (CPHA = 0)	243
17-4	Transmission Format (CPHA = 1)	244
17-5	Transmission Start Delay (Master)	246
17-6	Missed Read of Overflow Condition	248
17-7	Clearing SPRF When OVRF Interrupt Is Not Enabled	249
17-8	SPI Interrupt Request Generation	252
17-9	SPRF/SPTE CPU Interrupt Timing	253
17-10	CPHA/ \overline{SS} Timing	258
17-11	SPI Control Register (SPCR)	260
17-12	SPI Status and Control Register (SPSCR)	263
17-13	SPI Data Register (SPDR)	266
18-1	TIMB Block Diagram	269
18-2	TIMB I/O Register Summary	270
18-3	PWM Period and Pulse Width	275
18-4	TIMB Status and Control Register (TBSC)	281

List of Figures

18-5	TIMB Counter Registers (TBCNTH and TBCNTL)	284
18-6	TIMB Counter Modulo Registers (TBMODH and TBMODL)	285
18-7	TIMB Channel Status and Control Registers (TBSC0–TBSC1)	286
18-8	CHxMAX Latency	290
18-9	TIMB Channel Registers (TBCH0H/L–TBCH1H/L)	291
19-1	PIT Block Diagram	294
19-2	PIT I/O Register Summary	295
19-3	PIT Status and Control Register (PSC)	298
19-4	PIT Counter Registers (PCNTH–PCNTL)	300
19-5	PIT Counter Modulo Registers (PMDH–PMDL)	301
20-1	I/O Port Register Summary	304
20-2	Port A Data Register (PTA)	305
20-3	Data Direction Register A (DDRA)	305
20-4	Port A I/O Circuit	306
20-5	Port B Data Register (PTB)	307
20-6	Data Direction Register B (DDRB)	308
20-7	Port B I/O Circuit	309
20-8	Port C Data Register (PTC)	310
20-9	Data Direction Register C (DDRC)	311
20-10	Port C I/O Circuit	312
20-11	Port D Data Register (PTD)	313
20-12	Data Direction Register D (DDRD)	314
20-13	Port D I/O Circuit	315
20-14	Port E Data Register (PTE)	316
20-15	Data Direction Register E (DDRE)	318
20-16	Port E I/O Circuit	319
20-17	Port F Data Register (PTF)	320
20-18	Data Direction Register F (DDRF)	321
20-19	Port F I/O Circuit	321
21-1	Keyboard Module Block Diagram	325
21-2	I/O Register Summary	325
21-3	Keyboard Status and Control Register (KBSCR)	329
21-4	Keyboard Interrupt Enable Register (KBIER)	330
22-1	TIMA Block Diagram	333
22-2	TIMA I/O Register Summary	334
22-3	PWM Period and Pulse Width	340
22-4	TIMA Status and Control Register (TASC)	347

22-5	TIMA Counter Registers (TACNTH and TACNTL)	350
22-6	TIMA Counter Modulo Registers (TAMODH and TAMODL)	351
22-7	TIMA Channel Status and Control Registers (TASC0–TASC5)	352
22-8	CHxMAX Latency	357
22-9	TIMA Channel Registers (TACH0H/L–TACH5H/L)	358
23-1	ADC Block Diagram	363
23-2	ADC Status and Control Register (ADSCR)	367
23-3	ADC Data Register (ADR)	370
23-4	ADC Input Clock Register (ADICLK)	370
24-1	BDLC Block Diagram	376
24-2	BDLC Operating Modes State Diagram	377
24-3	BDLC Block Diagram	380
24-4	BDLC Rx Digital Filter Block Diagram	381
24-5	J1850 Bus Message Format (VPW)	383
24-6	J1850 VPW Symbols with Nominal Symbol Times	388
24-7	J1850 VPW Received Passive Symbol Times	391
24-8	J1850 VPW Received Passive EOF and IFS Symbol Times	392
24-9	J1850 VPW Received Active Symbol Times	393
24-10	J1850 VPW Received BREAK Symbol Times	394
24-11	J1850 VPW Bitwise Arbitrations	395
24-12	BDLC Block Diagram	396
24-13	BDLC Protocol Handler Outline	397
24-14	BDLC Block Diagram	402
24-15	BDLC Analog and Roundtrip Delay Register (BARD)	403
24-16	BDLC Control Register 1 (BCR1)	404
24-17	BDLC Control Register 2 (BCR2)	407
24-18	Types of In-Frame Response (IFR)	410
24-19	BDLC State Vector Register (BSVR)	414
24-20	BDLC Data Register (BDR)	416
25-1	SPI Master Timing Diagram	426
25-2	SPI Slave Timing Diagram	427
25-3	BDLC Variable Pulse Width Modulation (VPW) Symbol Timing	433

List of Figures

List of Tables

Table	Title	Page
1-1	External Pins Summary	33
1-3	Clock Source Summary	35
1-2	Clock Signal Naming Conventions	35
1-4	MC Order Numbers	36
2-1	Vector Addresses	46
5-1	EEPROM Array Address Blocks	68
5-2	Example Selective Bit Programming Description	69
5-3	EEPROM Program/Erase Mode Select	73
5-4	EEPROM Block Protect and Security Summary	76
6-1	Instruction Set Summary	91
6-2	Opcode Map	100
7-1	I/O Register Address Summary	104
7-2	Signal Name Conventions	104
7-3	PIN Bit Set Timing	106
8-1	I/O Register Address Summary	127
8-2	Variable Definitions	131
8-3	VCO Frequency Multiplier (N) Selection	142
11-1	I/O Register Address Summary	159
12-1	Mode Selection	166
12-2	Mode Differences	167
12-3	READ (Read Memory) Command	169
12-4	WRITE (Write Memory) Command	170
12-5	IREAD (Indexed Read) Command	170
12-6	IWRITE (Indexed Write) Command	171
12-7	READSP (Read Stack Pointer) Command	171
12-8	RUN (Run User Program) Command	172
12-9	MC68HC908AS60A Monitor Baud Rate Selection	172
14-1	LVIOUT Bit Indication	185
15-1	IRQ I/O Register Summary	189
16-1	Pin Name Conventions	197

List of Tables

16-2	SCI I/O Register Address Summary	199
16-3	SCI Transmitter I/O Address Summary	203
16-4	SCI Receiver I/O Address Summary	207
16-5	Start Bit Verification	209
16-6	Data Bit Recovery	210
16-7	Stop Bit Recovery	210
16-8	Character Format Selection	220
16-9	SCI Baud Rate Prescaling	232
16-10	SCI Baud Rate Selection	232
16-11	SCI Baud Rate Selection Examples	233
17-1	Pin Name Conventions	237
17-2	I/O Register Addresses	237
17-3	SPI I/O Register Summary	238
17-4	SPI Interrupts	251
17-5	SPI Configuration	259
17-6	SPI Master Baud Rate Selection	265
18-1	Prescaler Selection	283
18-2	Mode, Edge, and Level Selection	289
19-1	PIT I/O Register Address Summary	295
19-2	Prescaler Selection	299
20-1	Port A Pin Functions	306
20-2	Port B Pin Functions	309
20-3	Port C Pin Functions	312
20-4	Port D Pin Functions	315
20-5	Port E Pin Functions	319
20-6	Port F Pin Functions	322
21-1	I/O Register Address Summary	325
22-1	Prescaler Selection	349
22-2	Mode, Edge, and Level Selection	356
23-1	Mux Channel Select	368
23-2	ADC Clock Divide Ratio	371
24-1	BDLC I/O Register Summary	376
24-2	BDLC J1850 Bus Error Summary	401
24-3	BDLC Transceiver Delay	404
24-4	BDLC Rate Selection	406
24-5	BDLC Transmit In-Frame Response Control Bit Priority Encoding	409
24-6	BDLC Interrupt Sources	415

Section 1. General Description

1.1 Contents

1.2	Introduction	1.226
1.3	Features	26
1.4	MCU Block Diagram	27
1.5	Pin Assignments	29
1.5.1	Power Supply Pins (V_{DD} and V_{SS})	30
1.5.2	Oscillator Pins (OSC1 and OSC2)	31
1.5.3	External Reset Pin (RST)	31
1.5.4	External Interrupt Pin (IRQ)	31
1.5.5	External Filter Capacitor Pin (CGMXFC)	31
1.5.6	External Filter Capacitor Pin (CGMXFC)	31
1.5.7	External Filter Capacitor Pin (CGMXFC)	31
1.5.8	ADC Reference High Voltage Pin (VREFH)	32
1.5.9	Port A Input/Output (I/O) Pins (PTA7–PTA0)	32
1.5.10	Port B I/O Pins (PTB7/ATD7–PTB0/ATD0)	32
1.5.11	Port C I/O Pins (PTC4–PTC0)	32
1.5.12	Port D I/O Pins (PTD6–PTD0/ATD8)	32
1.5.13	Port E I/O Pins (PTE7/SPSCK–PTE0/TxD)	32
1.5.14	Port F I/O Pins (PTF3–PTF0/TACH2)	33
1.5.15	BDLC Transmit Pin (BDTxD)	33
1.5.16	BDLC Receive Pin (BDRxD)	33
1.6	Ordering Information	36
1.6.1	MC Order Numbers	36

1.2 Introduction

The MC68HC908AS60A is a member of the low-cost, high-performance M68HC08 Family of 8-bit microcontroller units (MCUs). The M68HC08 Family is based on the customer-specified integrated circuit (CSIC) design strategy. All MCUs in the family use the enhanced M68HC08 central processor unit (CPU08) and are available with a variety of modules, memory sizes and types, and package types.

1.3 Features

Features of the MC68HC908AS60A include:

- High-Performance M68HC08 Architecture
- Fully Upward-Compatible Object Code with M6805, M146805, and M68HC05 Families
- 8.4 MHz Internal Bus Frequency
- 32,256 bytes of FLASH Electrically Erasable Read-Only Memory (FLASH)
- FLASH Data Security
- 512 bytes of On-Chip Electrically Erasable Programmable Read-Only Memory with Security Option (EEPROM)
- 1 Kbyte of On-Chip RAM
- Clock Generator Module (CGM)
- Serial Peripheral Interface Module (SPI)
- Serial Communications Interface Module (SCI)
- 8-Bit, 15-Channel Analog-to-Digital Converter (ADC-15)
- 16-Bit, 6-Channel Timer Interface Module (TIMA-6)
- Programmable Interrupt Timer (PIT)
- System Protection Features
 - Computer Operating Properly (COP) with Optional Reset
 - Low-Voltage Detection with Optional Reset

- Illegal Opcode Detection with Optional Reset
- Illegal Address Detection with Optional Reset
- Low-Power Design (Fully Static with Stop and Wait Modes)
- Master Reset Pin and Power-On Reset
- SAE J1850 Byte Data Link Controller Digital Module

Features of the CPU08 include:

- Enhanced HC05 Programming Model
- Extensive Loop Control Functions
- 16 Addressing Modes (Eight More Than the HC05)
- 16-Bit Index Register and Stack Pointer
- Memory-to-Memory Data Transfers
- Fast 8×8 Multiply Instruction
- Fast 16/8 Divide Instruction
- Binary-Coded Decimal (BCD) Instructions
- Optimization for Controller Applications
- C Language Support

1.4 MCU Block Diagram

Figure 1-1 shows the structure of the MC68HC908AS60A.

General Description

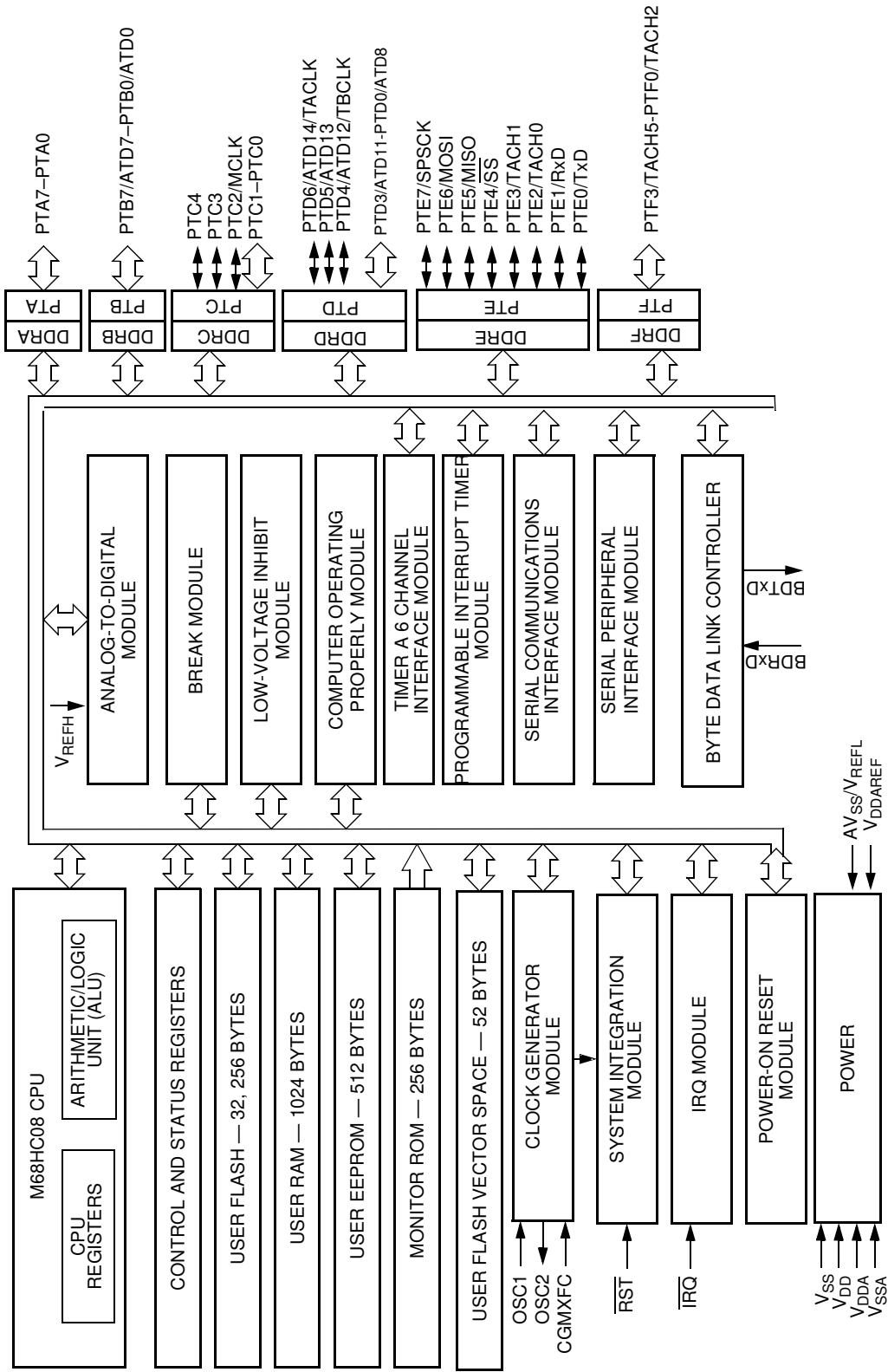

Figure 1-1. MCU Block Diagram for the MC68HC908AS32A (52-pin PLCC)

1.5 Pin Assignments

Figure 1-2 shows MC68HC908AS60A 52-pin PLCC pin assignments.

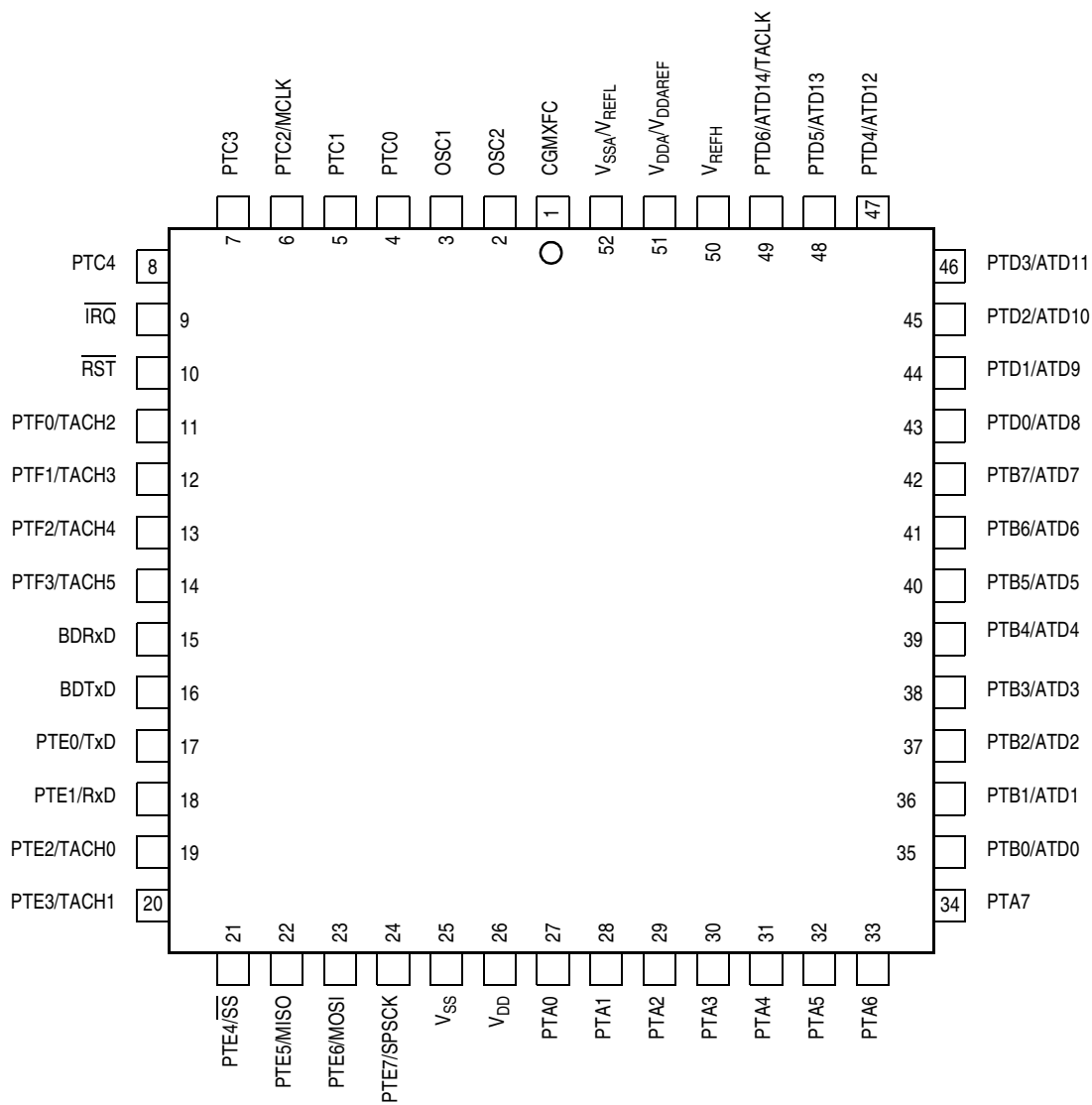

Figure 1-2. MC68HC908AS32A (52-Pin PLCC)

NOTE: The following pin descriptions are just a quick reference. For a more detailed representation, see [Input/Output Ports](#) on page 303.

1.5.1 Power Supply Pins (V_{DD} and V_{SS})

V_{DD} and V_{SS} are the power supply and ground pins. The MCU operates from a single power supply.

Fast signal transitions on MCU pins place high, short-duration current demands on the power supply. To prevent noise problems, take special care to provide power supply bypassing at the MCU as shown in [Figure 1-3](#). Place the C1 bypass capacitor as close to the MCU as possible. Use a high-frequency response ceramic capacitor for C1. C2 is an optional bulk current bypass capacitor for use in applications that require the port pins to source high current levels.

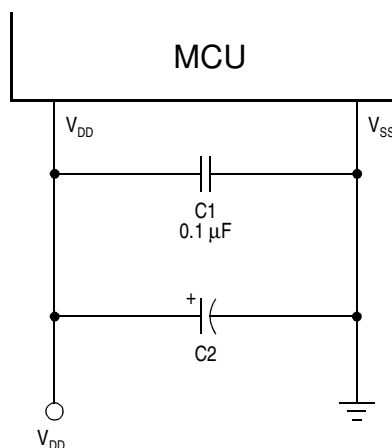

NOTE: Component values shown represent typical applications.

Figure 1-3. Power supply bypassing

V_{SS} is also the ground for the port output buffers and the ground return for the serial clock in the Serial Peripheral Interface module (SPI). See [Serial Peripheral Interface \(SPI\)](#) on page 235.

NOTE: V_{SS} must be grounded for proper MCU operation.

1.5.2 Oscillator Pins (OSC1 and OSC2)

The OSC1 and OSC2 pins are the connections for the on-chip oscillator circuit. See [Clock Generator Module \(CGM\)](#) on page 123.

1.5.3 External Reset Pin ($\overline{\text{RST}}$)

A logic 0 on the $\overline{\text{RST}}$ pin forces the MCU to a known startup state. $\overline{\text{RST}}$ is bidirectional, allowing a reset of the entire system. It is driven low when any internal reset source is asserted. See [System Integration Module \(SIM\)](#) on page 101 for more information.

1.5.4 External Interrupt Pin ($\overline{\text{IRQ}}$)

$\overline{\text{IRQ}}$ is an asynchronous external interrupt pin. See [External Interrupt Module \(IRQ\)](#) on page 187.

1.5.5 External Filter Capacitor Pin (CGMXFC)

CGMXFC is an external filter capacitor connection for the Clock Generator Module (CGM). See [Clock Generator Module \(CGM\)](#) on page 123.

1.5.6 Analog Power Supply Pin ($V_{\text{DDA}}/V_{\text{DDAREF}}$)

$V_{\text{DDA}}/V_{\text{DDAREF}}$ is the power supply pin for the analog portion of the Analog-to-Digital Converter (ADC) and the Clock Generator Module (CGM). See [Analog-to-Digital Converter \(ADC\)](#) on page 361. See [Clock Generator Module \(CGM\)](#) on page 123.

1.5.7 Analog Ground Pin ($V_{\text{SSA}}/V_{\text{REFL}}$)

The $V_{\text{SSA}}/V_{\text{REFL}}$ pin provides both the analog ground connection and the reference low voltage for the Analog-to-Digital Converter (ADC) as well as the ground connection for the Clock Generator Module (CGM). See [Analog-to-Digital Converter \(ADC\)](#) on page 361. See [Clock Generator Module \(CGM\)](#) on page 123.

1.5.8 ADC Reference High Voltage Pin (V_{REFH})

V_{REFH} provides the reference high voltage for the Analog-to-Digital Converter (ADC). See [Analog-to-Digital Converter \(ADC\)](#) on page 361.

1.5.9 Port A Input/Output (I/O) Pins (PTA7–PTA0)

PTA7–PTA0 are general-purpose bidirectional I/O port pins. See [Input/Output Ports](#) on page 303.

1.5.10 Port B I/O Pins (PTB7/ATD7–PTB0/ATD0)

Port B is an 8-bit special function port that shares all eight pins with the Analog-to-Digital Converter (ADC). See [Analog-to-Digital Converter \(ADC\)](#) on page 361 and [Input/Output Ports](#) on page 303.

1.5.11 Port C I/O Pins (PTC4–PTC0)

PTC4–PTC3 and PTC1–PTC0 are general-purpose bidirectional I/O port pins. PTC2/MCLK is a special function port that shares its pin with the system clock which has a frequency equivalent to the system clock. See [Input/Output Ports](#) on page 303.

1.5.12 Port D I/O Pins (PTD6–PTD0/ATD8)

Port D is an 7-bit special-function port that shares seven of its pins with the Analog-to-Digital Converter module (ADC-15), one of its pins with the Timer Interface Module A (TIMA). See [Timer Interface Module A \(TIMA\)](#) on page 331, [Analog-to-Digital Converter \(ADC\)](#) on page 361 and [Input/Output Ports](#) on page 303.

1.5.13 Port E I/O Pins (PTE7/SPSCK–PTE0/TxD)

Port E is an 8-bit special function port that shares two of its pins with the Timer Interface Module A (TIMA), four of its pins with the Serial Peripheral Interface module (SPI), and two of its pins with the Serial

Communication Interface module (SCI). See [Serial Communications Interface \(SCI\)](#) on page 195, [Serial Peripheral Interface \(SPI\)](#) on page 235, [Timer Interface Module A \(TIMA\)](#) on page 331, and [Input/Output Ports](#) on page 303.

1.5.14 Port F I/O Pins (PTF3–PTF0/TACH2)

Port F is a 4-bit special function port that shares four of its pins with the Timer Interface Module A (TIMA-6). See [Timer Interface Module A \(TIMA\)](#) on page 331, and [Input/Output Ports](#) on page 303.

1.5.15 BDLC Transmit Pin (BDTxD)

This pin is the digital output from the BDLC module (BDTxD). See [Electrical Specification](#) on page 419.

1.5.16 BDLC Receive Pin (BDRxD)

This pin is the digital input to the CAN module (BDRxD). See [Electrical Specification](#) on page 419.

Table 1-1. External Pins Summary

Pin Name	Function	Driver Type	Hysteresis ⁽¹⁾	Reset State
PTA7–PTA0	General-Purpose I/O	Dual State	No	Input Hi-Z
PTB7/ATD7–PTB0/ATD0	General-Purpose I/O ADC Channel	Dual State	No	Input Hi-Z
PTC4–PTC0	General-Purpose I/O	Dual State	No	Input Hi-Z
PTD6/ATD14/TACLK ADC Channel	General-Purpose I/O ADC Channel/Timer External Input Clock	Dual State	No	Input Hi-Z
PTD5/ATD13 ADC Channel	General-Purpose I/O ADC Channel	Dual State	No	Input Hi-Z
PTD4/ATD12/TBCLK ADC Channel	General-Purpose I/O ADC Channel/Timer External Input Clock	Dual State	No	Input Hi-Z
PTD3/ATD11–PTD0/ATD8 ADC Channels	General-Purpose I/O ADC Channel	Dual State	No	Input Hi-Z
PTE7/SPSCK	General-Purpose I/O SPI Clock	Dual State Open Drain	Yes	Input Hi-Z

Table 1-1. External Pins Summary (Continued)

Pin Name	Function	Driver Type	Hysteresis ⁽¹⁾	Reset State
PTE6/MOSI	General-Purpose I/O SPI Data Path	Dual State Open Drain	Yes	Input Hi-Z
PTE5/MISO	General-Purpose I/O SPI Data Path	Dual State Open Drain	Yes	Input Hi-Z
PTE4/ \overline{SS}	General-Purpose I/O SPI Slave Select	Dual State	Yes	Input Hi-Z
PTE3/TACH1	General-Purpose I/O Timer A Channel 1	Dual State	Yes	Input Hi-Z
PTE2/TACH0	General-Purpose I/O Timer A Channel 0	Dual State	Yes	Input Hi-Z
PTE1/RxD	General-Purpose I/O SCI Receive Data	Dual State	Yes	Input Hi-Z
PTE0/TxD	General-Purpose I/O SCI Transmit Data	Dual State	No	Input Hi-Z
PTF3/TACH5	General-Purpose I/O Timer A Channel 5	Dual State	Yes	Input Hi-Z
PTF2/TACH4	General-Purpose I/O Timer A Channel 4	Dual State	Yes	Input Hi-Z
PTF1/TACH3	General-Purpose I/O Timer A Channel 3	Dual State	Yes	Input Hi-Z
PTF0/TACH2	General-Purpose I/O Timer A Channel 2	Dual State	Yes	Input Hi-Z
V _{DD}	Chip Power Supply	N/A	N/A	N/A
V _{SS}	Chip Ground	N/A	N/A	N/A
V _{DDA} /V _{DDAREF}	ADC Analog Power Supply CGM Analog Power Supply	N/A	N/A	N/A
V _{SSA} /V _{REFL}	ADC Ground/ADC Reference Low Voltage CGM Analog Ground	N/A	N/A	N/A
V _{REFH}	A/D Reference High Voltage	N/A	N/A	N/A
OSC1	External Clock In	N/A	N/A	Input Hi-Z
OSC2	External Clock Out	N/A	N/A	Output
CGMXFC	PLL Loop Filter Cap	N/A	N/A	N/A
\overline{IRQ}	External Interrupt Request	N/A	N/A	Input Hi-Z
\overline{RST}	Reset	N/A	N/A	Output Low
BDRxD	BDLC Serial Input	N/A	Yes	Input Hi-Z
BDTxD	BDLC Serial Output	Output	No	Output

1. Hysteresis is not 100% tested but is typically a minimum of 300mV.

Table 1-2. Clock Signal Naming Conventions

Clock Signal Name	Description
CGMXCLK	Buffered version of OSC1 from Clock Generation Module (CGM)
CGMOUT	PLL-based or OSC1-based clock output from Clock Generator Module (CGM)
Bus Clock	CGMOUT divided by two
SPSCK	SPI serial clock
TACLK	External clock input for TIMA

Table 1-3. Clock Source Summary

Module	Clock Source
ADC	CGMXCLK or Bus Clock
CAN	CGMXCLK or CGMOUT
COP	CGMXCLK
CPU	Bus Clock
FLASH	Bus Clock
EEPROM	CGMXCLK or Bus Clock
RAM	Bus Clock
SPI	Bus Clock/SPSCK
SCI	CGMXCLK
TIMA	Bus Clock or PTD6/ATD14/TACLK
PIT	Bus Clock
SIM	CGMOUT and CGMXCLK
IRQ	Bus Clock
BRK	Bus Clock
LVI	Bus Clock
CGM	OSC1 and OSC2

1.6 Ordering Information

This section contains instructions for ordering the MC68HC908AS32A.

1.6.1 MC Order Numbers

Table 1-4. MC Order Numbers

MC Order Number	Operating Temperature Range
MC68HC908AS32ACFN (52-Pin PLCC)	-40C to + 85C
MC68HC908AS32AVFN (52-Pin PLCC)	-40C to + 105C
MC68HC908AS32AMFN (52-Pin PLCC)	-40C to + 125C

Section 2. Memory Map

2.1 Contents

2.2	Introduction	37
2.3	I/O Section	41
2.4	Additional Status and Control Registers	45
2.5	Vector Addresses and Priority	46

2.2 Introduction

The CPU08 can address 64K bytes of memory space. The memory map, shown in **Figure 2-1**, includes:

- 32,256 Bytes of FLASH EEPROM
- 1024 Bytes of RAM
- 512 Bytes of EEPROM with Protect Option
- 52 Bytes of User-Defined Vectors
- 256 Bytes of Monitor ROM

The following definitions apply to the memory map representation of reserved and unimplemented locations.

- **Reserved** — Accessing a reserved location can have unpredictable effects on MCU operation.
- **Unused** — These locations are reserved in the memory map for future use, accessing an unused location can have unpredictable effects on MCU operation.
- **Unimplemented** — Accessing an unimplemented location can cause an illegal address reset (within the constraints as outlined in the **Memory Map**).

Memory Map

MC68HC908AS32A

\$0000	I/O REGISTERS (80 BYTES)	\$0000
↓		↓
\$004F	RAM (1024 BYTES)	\$004F
↓		↓
\$0050	UNIMPLEMENTED (944 BYTES)	\$0050
↓		↓
\$044F		↓
\$0450	EEPROM (512 BYTES)	\$0450
↓		↓
\$07FF		↓
\$0800	UNIMPLEMENTED (1536 BYTES)	\$0800
↓		↓
\$09FF		↓
\$0A00	UNIMPLEMENTED (28,672 BYTES)	\$0A00
↓		↓
\$0FFF		↓
\$1000	FLASH (32,256 BYTES)	\$1000
↓		↓
\$7FFF		↓
\$8000	SIM BREAK STATUS REGISTER (SBSR)	\$8000
↓		↓
\$FDFF	SIM RESET STATUS REGISTER (SRSR)	\$FDFF
\$FE00		↓
\$FE01	RESERVED	\$FE01
\$FE02		↓
\$FE03	SIM BREAK FLAG CONTROL REGISTER (SBFCR)	\$FE03
\$FE04		↓
\$FE08	RESERVED	\$FE04
↓		↓
\$FE09	CONFIGURATION WRITE-ONCE REGISTER 2 (CONFIG-2)	\$FE08
		↓
		\$FE09

\$FE0A	RESERVED	\$FE0A
\$FE0B	RESERVED	\$FE0B
\$FE0C	BREAK ADDRESS REGISTER HIGH (BRKH)	\$FE0C
\$FE0D	BREAK ADDRESS REGISTER LOW (BRKL)	\$FE0D
\$FE0E	BREAK STATUS AND CONTROL REGISTER (BSCR)	\$FE0E
\$FE0F	LVI STATUS REGISTER (LVISR)	\$FE0F
\$FE10	EEPROM EEDIVH NON-VOLATILE REGISTER (EEDIVHNVR)	\$FE10
\$FE11	EEPROM EEDIVL NON-VOLATILE REGISTER (EEDIVLNVR)	\$FE11
\$FE12	RESERVED	\$FE12
↓		↓
\$FE19		\$FE19
\$FE1A	EEPROM EE DIVIDER HIGH REGISTER (EEDIVH)	\$FE1A
\$FE1B	EEPROM EE DIVIDER LOW REGISTER (EEDIVL)	\$FE1B
\$FE1C	EEPROM NON-VOLATILE REGISTER (EENVR)	\$FE1C
\$FE1D	EEPROM CONTROL REGISTER (EECR)	\$FE1D
\$FE1E	RESERVED	\$FE1E
\$FE1F	EEPROM ARRAY CONFIGURATION REGISTER (EEACR)	\$FE1F
\$FE20	MONITOR ROM (256 BYTES)	\$FE20
↓		↓
\$FF1F		\$FF1F
\$FF20	UNIMPLEMENTED (80 BYTES)	\$FF20
↓		↓
\$FF7F		\$FF7F
\$FF80	FLASH BLOCK PROTECT REGISTER (FLBPR)	\$FF80
\$FF81	RESERVED (7 BYTES)	\$FF82
↓		↓
\$FF87		\$FF87
\$FF88	FLASH CONTROL REGISTER (FLCR)	\$FF88
\$FF89	RESERVED	\$FF89
\$FF8A	RESERVED	\$FF8A

Memory Map

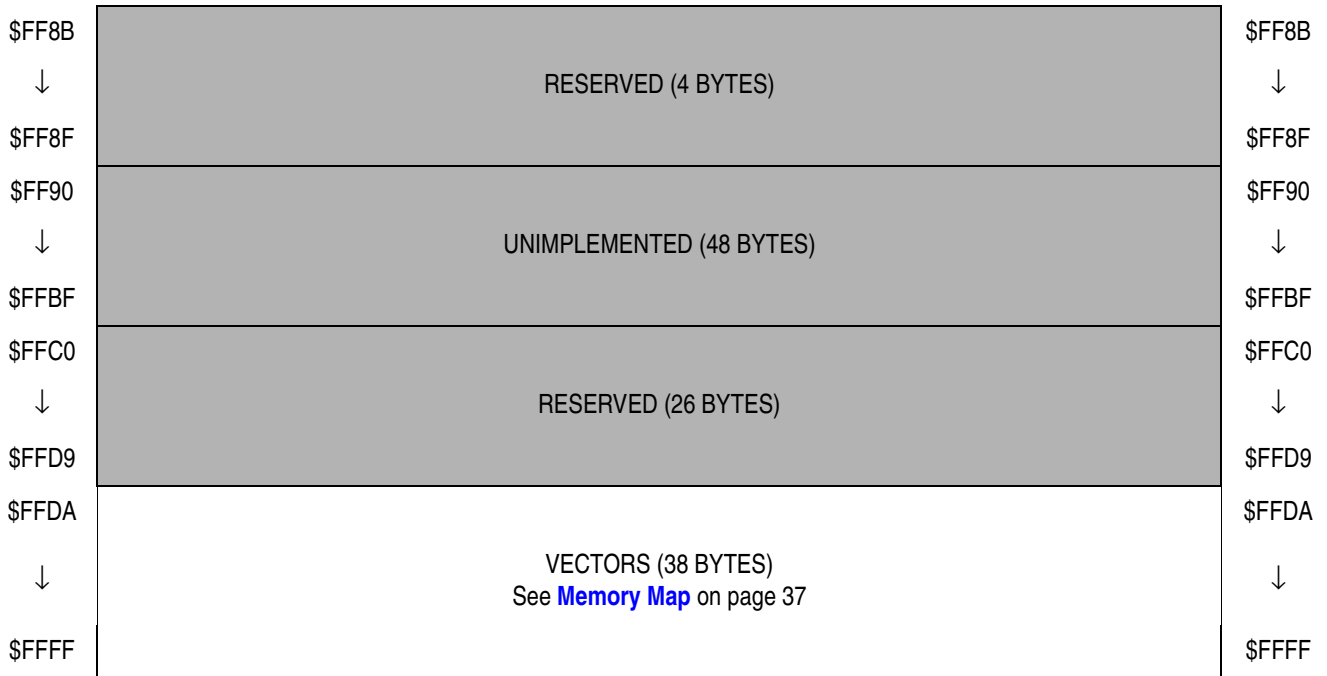

Figure 2-1. Memory Map (Continued)

2.3 I/O Section

Addresses \$0000–\$004F, shown in [Figure 2-2](#), contain the I/O Data, Status and Control Registers.

Addr.	Register Name		Bit 7	6	5	4	3	2	1	Bit 0
\$0000	Port A Data Register (PTA)	Read:	PTA7	PTA6	PTA5	PTA4	PTA3	PTA2	PTA1	PTA0
		Write:								
\$0001	Port B Data Register (PTB)	Read:	PTB7	PTB6	PTB5	PTB4	PTB3	PTB2	PTB1	PTB0
		Write:								
\$0002	Port C Data Register (PTC)	Read:	0	0	0	PTC4	PTC3	PTC2	PTC1	PTC0
		Write:								
\$0003	Port D Data Register (PTD)	Read:	0	PTD6	PTD5	PTD4	PTD3	PTD2	PTD1	PTD0
		Write:								
\$0004	Data Direction Register A (DDRA)	Read:	DDRA7	DDRA6	DDRA5	DDRA4	DDRA3	DDRA2	DDRA1	DDRA0
		Write:								
\$0005	Data Direction Register B (DDRB)	Read:	DDRB7	DDRB6	DDRB5	DDRB4	DDRB3	DDRB2	DDRB1	DDRB0
		Write:								
\$0006	Data Direction Register C (DDRC)	Read:	MCLKEN	0	0	DDRC4	DDRC3	DDRC2	DDRC1	DDRC0
		Write:								
\$0007	Data Direction Register D (DDRD)	Read:	0	DDRD6	DDRD5	DDRD4	DDRD3	DDR2	DDRD1	DDRD0
		Write:								
\$0008	Port E Data Register (PTE)	Read:	PTE7	PTE6	PTE5	PTE4	PTE3	PTE2	PTE1	PTE0
		Write:								
\$0009	Port F Data Register (PTF)	Read:	0	0	0	0	PTF3	PTF2	PTF1	PTF0
		Write:								
\$000C	Data Direction Register E (DDRE)	Read:	DDRE7	DDRE6	DDRE5	DDRE4	DDRE3	DDRE2	DDRE1	DDRE0
		Write:								
\$000D	Data Direction Register F (DDRF)	Read:	0	0	0	0	DDRF3	DDRF2	DDRF1	DDRF0
		Write:								
\$0010	SPI Control Register (SPCR)	Read:	SPRIE	R	SPMSTR	CPOL	CPHA	SPWOM	SPE	SPTIE
		Write:								
\$0011	SPI Status and Control Register (SPSCR)	Read:	SPRF	0	OVRF	MODF	SPTIE	0	SPR1	SPR0
		Write:								
\$0012	SPI Data Register (SPDR)	Read:	R7	R6	R5	R4	R3	R2	R1	R0
		Write:	T7	T6	T5	T4	T3	T2	T1	T0
\$0013	SCI Control Register 1 (SCC1)	Read:	LOOPS	ENSCI	TXINV	M	WAKE	ILTY	PEN	PTY
		Write:								

Figure 2-2. I/O Data, Status and Control Registers (Sheet 1 of 4)

Memory Map

Addr.	Register Name		Bit 7	6	5	4	3	2	1	Bit 0
\$0014	SCI Control Register 2 (SCC2)	Read:	SCTIE	TCIE	SCRIE	ILIE	TE	RE	RWU	SBK
		Write:								
\$0015	SCI Control Register 3 (SCC3)	Read:	R8	T8	R	R	ORIE	NEIE	FEIE	PEIE
		Write:								
\$0016	SCI Status Register 1 (SCS1)	Read:	SCTE	TC	SCRf	IDLE	OR	NF	FE	PE
		Write:								
\$0017	SCI Status Register 2 (SCS2)	Read:	0	0	0	0	0	0	BKF	RPF
		Write:								
\$0018	SCI Data Register (SCDR)	Read:	R7	R6	R5	R4	R3	R2	R1	R0
		Write:	T7	T6	T5	T4	T3	T2	T1	T0
\$0019	SCI Baud Rate Register (SCBR)	Read:	0	0	SCP1	SCP0	0	SCR2	SCR1	SCR0
		Write:								
\$001A	IRQ Status and Control Register (ISCR)	Read:	0	0	0	0	IRQF	0	IMASK	MODE
		Write:						ACK		
\$001C	PLL Control Register (PCTL)	Read:	PLLIE	PLLf	PLLON	BCS	1	1	1	1
		Write:								
\$001D	PLL Bandwidth Control Register (PBWC)	Read:	AUTO	LOCK	ACQ	XLD	0	0	0	0
		Write:								
\$001E	PLL Programming Register (PPG)	Read:	MUL7	MUL6	MUL5	MUL4	VRS7	VRS6	VRS5	VRS4
		Write:								
\$001F	Configuration Write-Once Register (CONFIG-1)	Read:	LVISTOP	R	LVIRST	LVIPWR	SSREC	COPL	STOP	COPD
		Write:								
\$0020	Timer A Status and Control Register (TASC)	Read:	TOF	TOIE	TSTOP	0	0	PS2	PS1	PS0
		Write:	0			TRST				
\$0022	Timer A Counter Register High (TACNTH)	Read:	Bit 15	14	13	12	11	10	9	Bit 8
		Write:								
\$0023	Timer A Counter Register Low (TACNTL)	Read:	Bit 7	6	5	4	3	2	1	Bit 0
		Write:								
\$0024	Timer A Modulo Register High (TAMODH)	Read:	Bit 15	14	13	12	11	10	9	Bit 8
		Write:								
\$0025	Timer A Modulo Register Low (TAMODL)	Read:	Bit 7	6	5	4	3	2	1	Bit 0
		Write:								
\$0026	Timer A Channel 0 Status and Control Register (TASC0)	Read:	CH0F	CH0IE	MS0B	MS0A	ELS0B	ELS0A	TOV0	CH0MAX
		Write:	0							
\$0027	Timer A Channel 0 Register High (TACH0H)	Read:	Bit 15	14	13	12	11	10	9	Bit 8
		Write:								

Figure 2-2. I/O Data, Status and Control Registers (Sheet 2 of 4)

Addr.	Register Name		Bit 7	6	5	4	3	2	1	Bit 0
\$0028	Timer A Channel 0 Register Low (TACH0L)	Read:	Bit 7	6	5	4	3	2	1	Bit 0
		Write:								
\$0029	Timer A Channel 1 Status and Control Register (TASC1)	Read:	CH1F	CH1IE	0	MS1A	ELS1B	ELS1A	TOV1	CH1MAX
		Write:	0							
\$002A	Timer A Channel 1 Register High (TACH1H)	Read:	Bit 15	14	13	12	11	10	9	Bit 8
		Write:								
\$002B	Timer A Channel 1 Register Low (TACH1L)	Read:	Bit 7	6	5	4	3	2	1	Bit 0
		Write:								
\$002C	Timer A Channel 2 Status and Control Register (TASC2)	Read:	CH2F	CH2IE	MS2B	MS2A	ELS2B	ELS2A	TOV2	CH2MAX
		Write:	0							
\$002D	Timer A Channel 2 Register High (TACH2H)	Read:	Bit 15	14	13	12	11	10	9	Bit 8
		Write:								
\$002E	Timer A Channel 2 Register Low (TACH2L)	Read:	Bit 7	6	5	4	3	2	1	Bit 0
		Write:								
\$002F	Timer A Channel 3 Status and Control Register (TASC3)	Read:	CH3F	CH3IE	0	MS3A	ELS3B	ELS3A	TOV3	CH3MAX
		Write:	0							
\$0030	Timer A Channel 3 Register High (TACH3H)	Read:	Bit 15	14	13	12	11	10	9	Bit 8
		Write:								
\$0031	Timer A Channel 3 Register Low (TACH3L)	Read:	Bit 7	6	5	4	3	2	1	Bit 0
		Write:								
\$0032	Timer A Channel 4 Status and Control Register (TASC4)	Read:	CH4F	CH4IE	MS4B	MS4A	ELS4B	ELS4A	TOV4	CH4MAX
		Write:	0							
\$0033	Timer A Channel 4 Register High (TACH4H)	Read:	Bit 15	14	13	12	11	10	9	Bit 8
		Write:								
\$0034	Timer A Channel 4 Register Low (TACH4L)	Read:	Bit 7	6	5	4	3	2	1	Bit 0
		Write:								
\$0035	Timer A Channel 5 Status and Control Register (TASC5)	Read:	CH5F	CH5IE	0	MS5A	ELS5B	ELS5A	TOV5	CH5MAX
		Write:	0							
\$0036	Timer A Channel 5 Register High (TACH5H)	Read:	Bit 15	14	13	12	11	10	9	Bit 8
		Write:								
\$0037	Timer A Channel 5 Register Low (TACH5L)	Read:	Bit 7	6	5	4	3	2	1	Bit 0
		Write:								
\$0038	Analog-to-Digital Status and Control Register (ADSCR)	Read:	COCO	AIEN	ADCO	ADCH4	ADCH3	ADCH2	ADCH1	ADCH0
		Write:	R							
\$0039	Analog-to-Digital Data Register (ADR)	Read:	AD7	AD6	AD5	AD4	AD3	AD2	AD1	AD0
		Write:								

Figure 2-2. I/O Data, Status and Control Registers (Sheet 3 of 4)

Memory Map

Addr.	Register Name		Bit 7	6	5	4	3	2	1	Bit 0
\$003A	Analog-to-Digital Input Clock Register (ADICLK)	Read:	ADIV2	ADIV1	ADIV0	ADICLK	0	0	0	0
		Write:								
\$003B	BDLC Analog and Roundtrip Delay Register (BARD)	Read:	ATE	RXPOL	0	0	BO3	BO2	BO1	BO0
		Write:			R	R				
\$003C	BDLC Control Register 1 (BCR1)	Read:	IMSG	CLKS	R1	R0	0	0	IE	WCM
		Write:					R	R		
\$003D	BDLC Control Register 2 (BCR2)	Read:	ALOOP	DLOOP	RX4XE	NBFS	TEOD	TSIFR	TMIFR1	TMIFR0
\$003E	BDLC State Vector Register (BSVR)	Read:	0	0	I3	I2	I1	I0	0	0
		Write:	R	R	R	R	R	R	R	R
\$003F	BDLC Data Register (BDR)	Read:	BD7	BD6	BD5	BD4	BD3	BD2	BD1	BD0
		Write:								
\$004B	PIT Status and Control Register (PSC)	Read:	POF	PIE	PSTOP	0	0	PPS2	PPS1	PPS0
		Write:	0			PRST				
\$004C	PIT Counter Register High (PCNTH)	Read:	Bit 15	14	13	12	11	10	9	Bit 8
		Write:								
\$004D	PIT Counter Register Low (PCNTL)	Read:	Bit 7	6	5	4	3	2	1	Bit 0
		Write:								
\$004E	PIT Modulo Register High (PMDH)	Read:	Bit 15	14	13	12	11	10	9	Bit 8
		Write:								
\$004F	PIT Modulo Register Low (PMDL)	Read:	Bit 7	6	5	4	3	2	1	Bit 0
		Write:								

= Unimplemented

R = Reserved

Figure 2-2. I/O Data, Status and Control Registers (Sheet 4 of 4)

2.4 Additional Status and Control Registers

Selected addresses in the range \$FE00 to \$FF88 contain additional Status and Control registers as shown in [Figure 2-3](#). A noted exception is the COP Control Register (COPCTL at address \$FFFF).

Addr.	Register Name		Bit 7	6	5	4	3	2	1	Bit 0
\$FE00	SIM Break Status Register (SBSR)	Read: Write:	R	R	R	R	R	R	BW	R
\$FE01	SIM Reset Status Register (SRSR)	Read: Write:	POR	PIN	COP	ILOP	ILAD	0	LVI	0
\$FE03	SIM Break Flag Control Register (SBFCR)	Read: Write:	BCFE	R	R	R	R	R	R	R
\$FE09	Configuration Write-Once Register (CONFIG-2)	Read: Write:	EEDIVCLK	R	R	R	AS32A	R	R	R
\$FE0C	Break Address Register High (BRKH)	Read: Write:	Bit 15	14	13	12	11	10	9	Bit 8
\$FE0D	Break Address Register Low (BRKL)	Read: Write:	Bit 7	6	5	4	3	2	1	Bit 0
\$FE0E	Break Status and Control Register (BRKSCR)	Read: Write:	BRKE	BRKA	0	0	0	0	0	0
\$FE0F	LVI Status Register (LVISR)	Read: Write:	LVIOUT	0	0	0	0	0	0	0
\$FE10	EEDIV Hi Non-volatile Register (EEDIVHNVR)	Read: Write:	EEDIVSECD					EEDIV10	EEDIV9	EEDIV8
\$FE11	EEDIV Lo Non-volatile Register (EEDIVLNVR)	Read: Write:	EEDIV7	EEDIV6	EEDIV5	EEDIV4	EEDIV3	EEDIV2	EEDIV1	EEDIV0
\$FE1A	EEDIV Divider High Register (EEDIVH)	Read: Write:	EEDIVSECD					EEDIV10	EEDIV9	EEDIV8
\$FE1B	EEDIV Divider Low Register (EEDIVL)	Read: Write:	EEDIV7	EEDIV6	EEDIV5	EEDIV4	EEDIV3	EEDIV2	EEDIV1	EEDIV0
\$FE1C	EEPROM Nonvolatile Register (EENVR)	Read: Write:				EERPRTCT	EEBP3	EEBP2	EEBP1	EEBP0
\$FE1D	EEPROM Control Register (EECR)	Read: Write:		0	EEOFF	EERAS1	EERAS0	EELAT	AUTO	EEPGM
\$FE1F	EEPROM Array Configuration Register (EEACR)	Read: Write:				EERPRTCT	EEBP3	EEBP2	EEBP1	EEBP0

Figure 2-3. Additional Status and Control Registers (Sheet 1 of 2)

Memory Map

Addr.	Register Name		Bit 7	6	5	4	3	2	1	Bit 0
\$FF80	FLASH Block Protect Register (FLBPR)	Read:	BPR7	BPR6	BPR5	BPR4	BPR3	BPR2	BPR1	BPR0
		Write:								
\$FF88	FLASH Control Register (FLCR)	Read:	0	0	0	0	HVEN	VERF	ERASE	PGM
		Write:								
\$FFFF	COP Control Register (COPCTL)	Read:	LOW BYTE OF RESET VECTOR							
		Write:	WRITING TO \$FFFF CLEARS COP COUNTER							



= Unimplemented

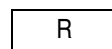

= Reserved

Figure 2-3. Additional Status and Control Registers (Sheet 2 of 2)

2.5 Vector Addresses and Priority

Addresses in the range \$FFDA to \$FFFF contain the user-specified vector locations. The vector addresses are shown in [Table 2-1](#). It is recommended that all vector addresses are defined.

Table 2-1. Vector Addresses

		Vector	
		MC68HC908AS32A	
Address			
\$FFDA	Lowest Priority 	PIT Vector (High)	
\$FFDB		PIT Vector (Low)	
\$FFDC		BDLC Vector (High)	
\$FFDD		BDLC Vector (Low)	
\$FFDE		ADC Vector (High)	
\$FFDF		ADC Vector (Low)	
\$FFE0		SCI Transmit Vector (High)	
\$FFE1		SCI Transmit Vector (Low)	
\$FFE2		SCI Receive Vector (High)	
\$FFE3		SCI Receive Vector (Low)	
\$FFE4		SCI Error Vector (High)	
\$FFE5		SCI Error Vector (Low)	
\$FFE6		SPI Transmit Vector (High)	

Table 2-1. Vector Addresses

		Vector
Address	MC68HC908AS32A	
\$FFE7		SPI Transmit Vector (Low)
\$FFE8		SPI Receive Vector (High)
\$FFE9		SPI Receive Vector (Low)
\$FFEA		TIMA Overflow Vector (High)
\$FFEB		TIMA Overflow Vector (Low)
\$FFEC		TIMA Channel 5 Vector (High)
\$FFED		TIMA Channel 5 Vector (Low)
\$FFEE		TIMA Channel 4 Vector (High)
\$FFEF		TIMA Channel 4 Vector (Low)
\$FFF0		TIMA Channel 3 Vector (High)
\$FFF1		TIMA Channel 3 Vector (Low)
\$FFF2		TIMA Channel 2 Vector (High)
\$FFF3		TIMA Channel 2 Vector (Low)
\$FFF4		TIMA Channel 1 Vector (High)
\$FFF5		TIMA Channel 1 Vector (Low)
\$FFF6		TIMA Channel 0 Vector (High)
\$FFF7		TIMA Channel 0 Vector (Low)
\$FFF8		PLL Vector (High)
\$FFF9		PLL Vector (Low)
\$FFFA		IRQ1 Vector (High)
\$FFFFB		IRQ1 Vector (Low)
\$FFFC		SWI Vector (High)
\$FFFD		SWI Vector (Low)
\$FFFE		Reset Vector (High)
\$FFFF		Reset Vector (Low)

Highest Priority

Section 3. RAM

3.1 Contents

3.2	Introduction	49
3.3	Functional Description	49

3.2 Introduction

This section describes the 1024 bytes of random-access memory (RAM).

3.3 Functional Description

Address \$0050 through \$044F is the RAM location. The 16-bit stack pointer allows the stack RAM to be anywhere in the 64K-byte memory space.

NOTE: *For correct operation, the stack pointer must point only to RAM locations.*

Within page zero are 176 bytes of RAM. Because the location of the stack RAM is programmable, all page zero RAM locations can be used for input/output (I/O) control and user data or code. When the stack pointer is moved from its reset location at \$00FF, direct addressing mode instructions can access all page zero RAM locations efficiently. Page zero RAM, therefore, provides ideal locations for frequently accessed global variables.

Before processing an interrupt, the CPU uses five bytes of the stack to save the contents of the CPU registers.

NOTE: *For M68HC05, M6805, and M146805 compatibility, the H register is not stacked.*

During a subroutine call, the CPU uses two bytes of the stack to store the return address. The stack pointer decrements during pushes and increments during pulls.

NOTE: *Be careful when using nested subroutines. The CPU could overwrite data in the RAM during a subroutine or during the interrupt stacking operation.*

Section 4. FLASH Memory

4.1 Contents

4.2	Introduction	51
4.3	Functional Description	52
4.4	FLASH Control and Block Protect Registers	52
4.4.1	FLASH Control Register	53
4.4.2	FLASH Block Protect Register	54
4.5	FLASH Block Protection	56
4.6	FLASH Mass Erase Operation	57
4.7	FLASH Page Erase Operation	58
4.8	FLASH Program Operation	59
4.9	Low-Power Modes	62
4.9.1	WAIT Mode	62
4.9.2	STOP Mode	62

4.2 Introduction

This section describes the operation of the embedded FLASH memory. This memory can be read, programmed and erased from a single external supply. The program and erase operations are enabled through the use of an internal charge pump.

4.3 Functional Description

The FLASH memory is an array of 32,256 bytes with one byte of block protection and an additional 38 bytes of user vectors. An erased bit reads as a logic 1 and a programmed bit reads as a logic 0.

Memory in the FLASH array is organized into rows within pages. There are two rows of memory per page with 64 bytes per row. The minimum erase block size is a single page, 128 bytes. Programming is performed on a per-row basis, 64 bytes at a time. Program and erase operations are facilitated through control bits in the FLASH Control Register (FLCR). Details for these operations appear later in this section.

The FLASH memory map consists of:

- \$8000–\$FDFF: User Memory (32,256 bytes)
- \$FF80: FLASH Block Protect Register (FLBPR)
- \$FF88: FLASH Control Register (FLCR)
- \$FFCC–\$FFFF: these locations are reserved for user-defined interrupt and reset vectors (Please see [Vector Addresses and Priority](#) on page 46 for details)

Programming tools are available from Motorola. Contact your local Motorola representative for more information.

NOTE: *A security feature prevents viewing of the FLASH contents.⁽¹⁾*

4.4 FLASH Control and Block Protect Registers

The FLASH array has two registers that control its operation, the FLASH Control Register (FLCR) and the FLASH Block Protect Register (FLBPR).

1. No security feature is absolutely secure. However, Motorola's strategy is to make reading or copying the FLASH difficult for unauthorized users.

4.4.1 FLASH Control Register

The FLASH Control Register (FLCR) controls FLASH program and erase operations.

Address: \$FF88

	Bit 7	6	5	4	3	2	1	Bit 0
Read:	0	0	0	0	HVEN	MASS	ERASE	PGM
Write:								
Reset:	0	0	0	0	0	0	0	0

Figure 4-1. FLASH Control Register (FLCR)

HVEN — High-Voltage Enable Bit

This read/write bit enables the charge pump to drive high voltages for program and erase operations in the array. HVEN can only be set if either PGM = 1 or ERASE = 1 and the proper sequence for program or erase is followed.

- 1 = High voltage enabled to array and charge pump on
- 0 = High voltage disabled to array and charge pump off

MASS — Mass Erase Control Bit

Setting this read/write bit configures the FLASH array for mass or page erase operation.

- 1 = Mass erase operation selected
- 0 = Page erase operation selected

ERASE — Erase Control Bit

This read/write bit configures the memory for erase operation. ERASE is interlocked with the PGM bit such that both bits cannot be set at the same time.

- 1 = Erase operation selected
- 0 = Erase operation unselected

PGM — Program Control Bit

This read/write bit configures the memory for program operation. PGM is interlocked with the ERASE bit such that both bits cannot be equal to 1 or set to 1 at the same time.

- 1 = Program operation selected
- 0 = Program operation unselected

4.4.2 FLASH Block Protect Register

The FLASH Block Protect Register (FLBPR) is implemented as a byte within the FLASH memory and therefore can only be written during a FLASH programming sequence. The value in this register determines the starting location of the protected range within the FLASH memory.

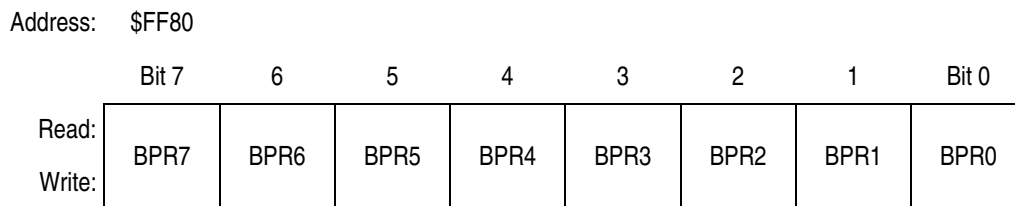

Figure 4-2. FLASH Block Protect Register (FLBPR)

FLBPR[7:0] — Block Protect Register Bit7 to Bit0

These eight bits represent bits [14:7] of a 16-bit memory address. Bit-15 is logic 1 and bits [6:0] are logic 0s.

The resultant 16-bit address is used for specifying the start address of the FLASH memory for block protection. FLASH is protected from this start address to the end of FLASH memory at \$FFFF. With this mechanism, the protect start address can be \$XX00 and \$XX80 (128 byte page boundaries) within the FLASH array.



Figure 4-3. FLASH Block Protect Start Address

FLASH Protected Ranges:

FLBPR[7:0]	Protected Range
\$FF	No Protection
\$FE	\$FF00 – \$FFFF
\$FD	\$FE80 – \$FFFF
↓	↓
\$0B	\$8580 – \$FFFF
\$0A	\$8500 – \$FFFF
\$09	\$8480 – \$FFFF
\$08	\$8400 – \$FFFF
↓	↓
\$04	\$8200 – \$FFFF
\$03	\$8180 – \$FFFF
\$02	\$8100 – \$FFFF
\$01	\$8080 – \$FFFF
\$00	\$8000 – \$FFFF

Decreasing the value in FLBPR by one increases the protected range by one page (128 bytes). However, programming the block protect register with \$FE protects a range twice that size, 256 bytes, in the corresponding array. \$FE means that locations \$FF00–\$FFFF are protected in FLASH.

The FLASH memory does not exist at some locations. The block protection range configuration is unaffected if FLASH memory does not exist in that range. Refer to the memory map and make sure that the desired locations are protected.

4.5 FLASH Block Protection

Due to the ability of the on-board charge pump to erase and program the FLASH memory in the target application, provision is made for protecting blocks of memory from unintentional erase or program operations due to system malfunction. This protection is done by using the FLASH Block Protection Register (FLBPR). FLBPR determines the range of the FLASH memory which is to be protected. The range of the protected area starts from a location defined by FLBPR and ends at the bottom of the FLASH memory (\$FFFF). When the memory is protected, the HVEN bit can not be set in either ERASE or PROGRAM operations.

NOTE: *In performing a program or erase operation, the FLASH Block Protect Register must be read after setting the PGM or ERASE bit and before asserting the HVEN bit.*

When the FLASH Block Protect Register is programmed with all 0's, the entire memory is protected from being programmed and erased. When all the bits are erased (all 1's), the entire memory is accessible for program and erase.

When bits within FLBPR are programmed (logic 0), they lock a block of memory address ranges as shown in [FLASH Block Protect Register](#) on page 54. If FLBPR is programmed with any value other than \$FF, the protected block of FLASH memory can not be erased or programmed.

NOTE: *The vector locations and the FLASH Block Protect Registers are located in the same page. FLBPR is not protected with special hardware or software; therefore, if this page is not protected by FLBPR and the vector locations are erased by either a page or a mass erase operation, FLBPR will also be erased.*

4.6 FLASH Mass Erase Operation

Use this step-by-step procedure to erase the entire FLASH memory to read as logic 1:

1. Set both the ERASE bit and the MASS bit in the FLASH Control Register (FLCR).
2. Read the FLASH Block Protect Register (FLBPR).
3. Write to any FLASH address within the FLASH array with any data.

NOTE: *If the address written to in Step 3 is within address space protected by the FLASH Block Protect Register (FLBPR), no erase will occur.*

4. Wait for a time, t_{NVS} .
5. Set the HVEN bit.
6. Wait for a time, t_{MERASE} .
7. Clear the ERASE bit.
8. Wait for a time, t_{NVHL} .
9. Clear the HVEN bit.
10. Wait for a time, t_{RCV} , after which the memory can be accessed in normal read mode.

NOTE: **A.** *Programming and erasing of FLASH locations can not be performed by code being executed from the same FLASH array.*

B. *While these operations must be performed in the order shown, other unrelated operations may occur between the steps. Care must be taken however to ensure that these operations do not access any address within the FLASH array memory space such as the COP Control Register (COPCTL) at \$FFFF.*

C. *It is highly recommended that interrupts be disabled during program/erase operations.*

4.7 FLASH Page Erase Operation

Use this step-by-step procedure to erase a page (128 bytes) of FLASH memory to read as logic 1:

1. Set the ERASE bit and clear the MASS bit in the FLASH Control Register (FLCR).
2. Read the FLASH Block Protect Register (FLBPR).
3. Write any data to any FLASH address within the address range of the page (128 byte block) to be erased.
4. Wait for time, t_{NVS} .
5. Set the HVEN bit.
6. Wait for time, t_{ERASE} .
7. Clear the ERASE bit.
8. Wait for time, t_{NVH} .
9. Clear the HVEN bit.
10. Wait for a time, t_{RCV} , after which the memory can be accessed in normal read mode.

NOTE: *A. Programming and erasing of FLASH locations can not be performed by code being executed from the same FLASH array.*

B. While these operations must be performed in the order shown, other unrelated operations may occur between the steps. Care must be taken however to ensure that these operations do not access any address within the FLASH array memory space such as the COP Control Register (COPCTL) at \$FFFF.

C. It is highly recommended that interrupts be disabled during program/erase operations.

4.8 FLASH Program Operation

Programming of the FLASH memory is done on a row basis. A row consists of 64 consecutive bytes with address ranges as follows:

- \$XX00 to \$XX3F
- \$XX40 to \$XX7F
- \$XX80 to \$XXBF
- \$XXC0 to \$XXFF

During the programming cycle, make sure that all addresses being written to fit within one of the ranges specified above. Attempts to program addresses in different row ranges in one programming cycle will fail. Use this step-by-step procedure to program a row of FLASH memory.

NOTE: *In order to avoid program disturbs, the row must be erased before any byte on that row is programmed.*

1. Set the PGM bit in the FLASH Control Register (FLCR). This configures the memory for program operation and enables the latching of address and data programming.
2. Read the FLASH Block Protect Register (FLBPR).
3. Write to any FLASH address within the row address range desired with any data.
4. Wait for time, t_{NVS} .
5. Set the HVEN bit.
6. Wait for time, t_{PGS} .
7. Write data byte to the FLASH address to be programmed.
8. Wait for time, t_{PROG} .
9. Repeat step 7 and 8 until all the bytes within the row are programmed.
10. Clear the PGM bit.
11. Wait for time, t_{NVH} .

12. Clear the HVEN bit.
13. Wait for a time, t_{RCV} , after which the memory can be accessed in normal read mode.

The FLASH Programming Algorithm Flowchart is shown in [Figure 4-4](#).

NOTE: **A.** *Programming and erasing of FLASH locations can not be performed by code being executed from the same FLASH array.*

B. *While these operations must be performed in the order shown, other unrelated operations may occur between the steps. Care must be taken however to ensure that these operations do not access any address within the FLASH array memory space such as the COP Control Register (COPCTL) at \$FFFF.*

C. *It is highly recommended that interrupts be disabled during program/erase operations.*

D. *Do not exceed t_{PROG} maximum or t_{HV} maximum. t_{HV} is defined as the cumulative high voltage programming time to the same row before next erase. t_{HV} must satisfy this condition: $t_{NVS} + t_{NVH} + t_{PGS} + (t_{PROG} \times 64) \leq t_{HV} \text{ max}$. Please also see [FLASH Memory Characteristics](#) on page 431.*

E. *The time between each FLASH address change (step 7 to step 7), or the time between the last FLASH address programmed to clearing the PGM bit (step 7 to step 10) must not exceed the maximum programming time, $t_{PROG} \text{ max}$.*

F. *Be cautious when programming the FLASH array to ensure that non-FLASH locations are not used as the address that is written to when selecting either the desired row address range in step 3 of the algorithm or the byte to be programmed in step 7 of the algorithm. This applies particularly to:*

- \$FFDA-\$FFFF (38 bytes)

**Algorithm for programming
a row (64 bytes) of FLASH memory**

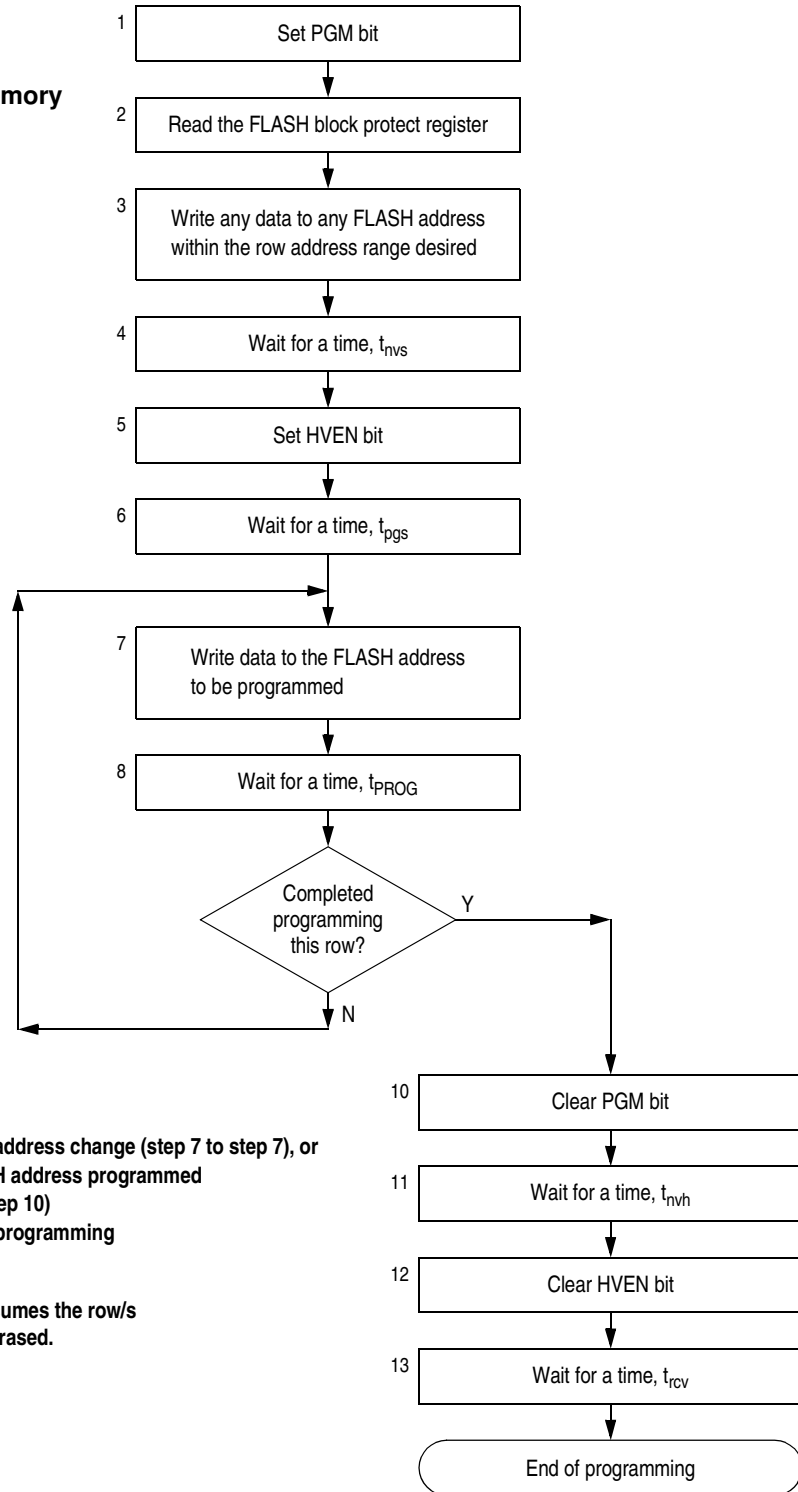

NOTE:

The time between each FLASH address change (step 7 to step 7), or the time between the last FLASH address programmed to clearing PGM bit (step 7 to step 10) must not exceed the maximum programming time, $t_{PROG\ max}$.

This row program algorithm assumes the row/s to be programmed are initially erased.

Figure 4-4. FLASH Programming Algorithm Flowchart

4.9 Low-Power Modes

The WAIT and STOP instructions will place the MCU in low power consumption standby modes.

4.9.1 WAIT Mode

Putting the MCU into wait mode while the FLASH is in read mode does not affect the operation of the FLASH memory directly; however, no memory activity will take place since the CPU is inactive.

The WAIT instruction should not be executed while performing a program or erase operation on the FLASH. Wait mode will suspend any FLASH program/erase operations and leave the memory in a Standby Mode.

4.9.2 STOP Mode

Putting the MCU into stop mode while the FLASH is in read mode does not affect the operation of the FLASH memory directly; however, no memory activity will take place since the CPU is inactive.

The STOP instruction should not be executed while performing a program or erase operation on the FLASH. Stop mode will suspend any FLASH program/erase operations and leave the memory in a Standby Mode.

NOTE: *Standby Mode is the power saving mode of the FLASH module, in which all internal control signals to the FLASH are inactive and the current consumption of the FLASH is minimum.*

Section 5. EEPROM Memory

5.1 Contents

5.2	Introduction	64
5.3	Features	64
5.4	EEPROM Register Summary	65
5.5	Functional Description	66
5.5.1	EEPROM Configuration	66
5.5.2	EEPROM Timebase Requirements	67
5.5.3	EEPROM Program/Erase Protection	67
5.5.4	EEPROM Block Protection	68
5.5.5	EEPROM Programming and Erasing	69
5.6	EEPROM Register Descriptions	73
5.6.1	EEPROM Control Register	73
5.6.2	EEPROM Array Configuration Register	75
5.6.3	EEPROM Nonvolatile Register	77
5.6.4	EEPROM Timebase Divider Register	78
5.6.5	EEPROM Timebase Divider Non-Volatile Register	80
5.7	Low-Power Modes	81
5.7.1	Wait Mode	81
5.7.2	Stop Mode	81

5.2 Introduction

This section describes the 512 bytes of electrically erasable programmable read-only memory (EEPROM) residing at address range \$0800 to \$09FF.

5.3 Features

Features of the EEPROM include the following:

- 512 bytes Non-Volatile Memory
- Byte, Block, or Bulk Erasable
- Non-Volatile EEPROM Configuration and Block Protection Options
- On-chip Charge Pump for Programming/Erasing
- Security Option
- AUTO Bit Driven Programming/Erasing Time Feature

5.4 EEPROM Register Summary

The EEPROM Register Summary is shown in [Figure 5-1](#).

Addr.	Register Name	Bit 7	6	5	4	3	2	1	Bit 0	
\$FE10	EEDIV Non-volatile Register High (EEDIVHNVR)*	Read:	EEDIVSECD	R	R	R	R	EEDIV10	EEDIV9	EEDIV8
		Write:								
		Reset:	Unaffected by reset; \$FF when blank							
\$FE11	EEDIV Non-volatile Register Low (EEDIVLNVR)*	Read:	EEDIV7	EEDIV6	EEDIV5	EEDIV4	EEDIV3	EEDIV2	EEDIV1	EEDIV0
		Write:								
		Reset:	Unaffected by reset; \$FF when blank							
\$FE1A	EE Divider Register High (EEDIVH)	Read:	EEDIVSECD	0	0	0	0	EEDIV10	EEDIV9	EEDIV8
		Write:								
		Reset:	Contents of EEDIVHNVR (\$FE10), Bits [6:3] = 0							
\$FE1B	EE Divider Register Low (EEDIVL)	Read:	EEDIV7	EEDIV6	EEDIV5	EEDIV4	EEDIV3	EEDIV2	EEDIV1	EEDIV0
		Write:								
		Reset:	Contents of EEDIVLNVR (\$FE11)							
\$FE1C	EEPROM Non-volatile Register (EENVR)*	Read:	UNUSED	UNUSED	UNUSED	EEPRTCT	EEBP3	EEBP2	EEBP1	EEBP0
		Write:								
		Reset:	Unaffected by reset; \$FF when blank; factory programmed \$F0							
\$FE1D	EEPROM Control Register (EECR)	Read:	UNUSED	0	EEOFF	EERAS1	EERAS0	EELAT	AUTO	EEPGM
		Write:								
		Reset:	0	0	0	0	0	0	0	0
\$FE1F	EEPROM Array Configuration Register (EEACR)	Read:	UNUSED	UNUSED	UNUSED	EEPRTCT	EEBP3	EEBP2	EEBP1	EEBP0
		Write:								
		Reset:	Contents of EENVR (\$FE1C)							

* Non-volatile EEPROM register; write by programming.

= Unimplemented R = Reserved UNUSED = Unused

Figure 5-1. EEPROM Register Summary

5.5 Functional Description

The 512 bytes of EEPROM are located at \$0800-\$09FF and can be programmed or erased without an additional external high voltage supply. The program and erase operations are enabled through the use of an internal charge pump. For each byte of EEPROM, the write/erase endurance is 10,000 cycles.

5.5.1 EEPROM Configuration

The 8-bit EEPROM Non-Volatile Register (EENVR) and the 16-bit EEPROM Timebase Divider Non-Volatile Register (EEDIVNVR) contain the default settings for the following EEPROM configurations:

- EEPROM Timebase Reference
- EEPROM Security Option
- EEPROM Block Protection

EENVR and EEDIVNVR are non-volatile EEPROM registers. They are programmed and erased in the same way as EEPROM bytes. The contents of these registers are loaded into their respective volatile registers during a MCU reset. The values in these read/write volatile registers define the EEPROM configurations.

For EENVR, the corresponding volatile register is the EEPROM Array Configuration Register (EEACR). For the EEDIVNVR (two 8-bit registers: EEDIVHNVR and EEDIVLNVR), the corresponding volatile register is the EEPROM Divider Register (EEDIV: EEDIVH and EEDIVL).

5.5.2 EEPROM Timebase Requirements

A 35 μ s timebase is required by the EEPROM control circuit for program and erase of EEPROM content. This timebase is derived from dividing the CGMXCLK or bus clock (selected by EEDIVCLK bit in CONFIG-2 Register) using a timebase divider circuit controlled by the 16-bit EEPROM Timebase Divider EEDIV Register (EEDIVH and EEDIVL).

As the CGMXCLK or bus clock is user selected, the EEPROM Timebase Divider Register must be configured with the appropriate value to obtain the 35 μ s. The timebase divider value is calculated by using the following formula:

$$\text{EEDIV} = \text{INT}[\text{Reference Frequency}(\text{Hz}) \times 35 \times 10^{-6} + 0.5]$$

This value is written to the EEPROM Timebase Divider Register (EEDIVH and EEDIVL) or programmed into the EEPROM Timebase Divider Non-Volatile Register prior to any EEPROM program or erase operations(see **EEPROM Configuration** on page 66 and **EEPROM Timebase Requirements** on page 67).

5.5.3 EEPROM Program/Erase Protection

The EEPROM has a special feature that designates the 16 bytes of addresses from \$08F0 to \$08FF to be permanently secured. This program/erase protect option is enabled by programming the EEPRTCT bit in the EEPROM Non-Volatile Register (EENVR) to a logic zero.

Once the EEPRTCT bit is programmed to 0 for the first time:

- Programming and erasing of secured locations \$08F0 to \$08FF is permanently disabled.
- Secured locations \$08F0 to \$08FF can be read as normal.
- Programming and erasing of EENVR is permanently disabled.
- Bulk and Block Erase operations are disabled for the unprotected locations \$0800-\$08EF, \$0900-\$09FF.

- Single byte program and erase operations are still available for locations \$0800-\$08EF and \$0900-\$09FF for all bytes that are not protected by the EEPROM Block Protect EEBPx bits (see [EEPROM Block Protection](#) on page 68 and [EEPROM Array Configuration Register](#) on page 75)

NOTE: *Once armed, the protect option is permanently enabled. As a consequence, all functions in the EENVR will remain in the state they were in immediately before the security was enabled.*

5.5.4 EEPROM Block Protection

The 512 bytes of EEPROM are divided into four 128-byte blocks. Each of these blocks can be protected from erase/program operations by setting the EEBPx bit in the EENVR. [Table 5-1](#) shows the address ranges for the blocks.

Table 5-1. EEPROM Array Address Blocks

Block Number (EEBPx)	Address Range
EEBP0	\$0800–\$087F
EEBP1	\$0880–\$08FF
EEBP2	\$0900–\$097F
EEBP3	\$0980–\$09FF

These bits are effective after a reset or a upon read of the EENVR register. The block protect configuration can be modified by erasing/programming the corresponding bits in the EENVR register and then reading the EENVR register. Please see [EEPROM Array Configuration Register](#) on page 75 for more information.

NOTE: *Once EEDIVSECD in the EEDIVHNVR is programmed to 0 and after a system reset, the EEDIV security feature is permanently enabled because the EEDIVSECD bit in the EEDIVH is always loaded with 0 thereafter. Once this security feature is armed, erase and program mode are disabled for EEDIVHNVR and EEDIVLNVR. Modifications to the EEDIVH and EEDIVL registers are also disabled. Therefore, be cautious on programming a value into the EEDIVHNVR.*

5.5.5 EEPROM Programming and Erasing

The unprogrammed or erase state of an EEPROM bit is a logic 1. The factory default for all bytes within the EEPROM array is \$FF.

The programming operation changes an EEPROM bit from logic 1 to logic 0 (programming cannot change a bit from logic 0 to a logic 1). In a single programming operation, the minimum EEPROM programming size is one bit; the maximum is eight bits (one byte).

The erase operation changes an EEPROM bit from logic 0 to logic 1. In a single erase operation, the minimum EEPROM erase size is one byte; the maximum is the entire EEPROM array.

The EEPROM can be programmed such that one or multiple bits are programmed (written to a logic 0) at a time. However, the user may never program the same bit location more than once before erasing the entire byte. In other words, the user is not allowed to program a logic 0 to a bit that is already programmed (bit state is already logic 0).

For some applications it might be advantageous to track more than 10K events with a single byte of EEPROM by programming one bit at a time. For that purpose, a special selective bit programming technique is available. An example of this technique is illustrated in [Table 5-2](#).

Table 5-2. Example Selective Bit Programming Description

Description	Program Data in Binary	Result in Binary
Original state of byte (erased)	n/a	1111:1111
First event is recorded by programming bit position 0	1111:1110	1111:1110
Second event is recorded by programming bit position 1	1111:1101	1111:1100
Third event is recorded by programming bit position 2	1111:1011	1111:1000
Fourth event is recorded by programming bit position 3	1111:0111	1111:0000
Events five through eight are recorded in a similar fashion		

Note that none of the bit locations are actually programmed more than once although the byte was programmed eight times.

When this technique is utilized, a program/erase cycle is defined as multiple program sequences (up to eight) to a unique location followed by a single erase operation.

Program/Erase Using AUTO Bit

An additional feature available for EEPROM program and erase operations is the AUTO mode. When enabled, AUTO mode will activate an internal timer that will automatically terminate the program/erase cycle and clear the EEPGM bit. Please see [EEPROM Programming](#) on page 70, [EEPROM Erasing](#) on page 71 and [EEPROM Control Register](#) on page 73 for more information.

EEPROM Programming

The unprogrammed or erase state of an EEPROM bit is a logic 1. Programming changes the state to a logic 0. Only EEPROM bytes in the non-protected blocks and the EENVR register can be programmed.

Use the following procedure to program a byte of EEPROM:

1. Clear EERAS1 and EERAS0 and set EELAT in the EECR.^(A)

NOTE: *If using the AUTO mode, also set the AUTO bit during Step 1.*

2. Write the desired data to the desired EEPROM address.^(B)
3. Set the EEPGM bit.^(C) Go to Step 7 if AUTO is set.
4. Wait for time, t_{EEPGM} , to program the byte.
5. Clear EEPGM bit.
6. Wait for time, t_{EEFPV} , for the programming voltage to fall. Go to Step 8.
7. Poll the EEPGM bit until it is cleared by the internal timer.^(D)
8. Clear EELAT bits.^(E)

NOTE: *A. EERAS1 and EERAS0 must be cleared for programming. Setting the EELAT bit configures the address and data buses to latch data for programming the array. Only data with a valid EEPROM address will be latched. If EELAT is set, other writes to the EECR will be allowed after a valid EEPROM write.*

B. If more than one valid EEPROM write occurs, the last address and data will be latched overriding the previous address and data. Once data is written to the desired address, do not read EEPROM locations other than the written location. (Reading an EEPROM location returns the latched data and causes the read address to be latched).

C. The EEPGM bit cannot be set if the EELAT bit is cleared or a non-valid EEPROM address is latched. This is to ensure proper programming sequence. Once EEPGM is set, do not read any EEPROM locations; otherwise, the current program cycle will be unsuccessful. When EEPGM is set, the on-board programming sequence will be activated.

D. The delay time for the EEPGM bit to be cleared in AUTO mode is less than t_{EEPGM} . However, on other MCUs, this delay time may be different. For forward compatibility, software should not make any dependency on this delay time.

E. Any attempt to clear both EEPGM and EELAT bits with a single instruction will only clear EEPGM. This is to allow time for removal of high voltage from the EEPROM array.

EEPROM Erasing

The programmed state of an EEPROM bit is logic 0. Erasing changes the state to a logic 1. Only EEPROM bytes in the non-protected blocks and the EENVR register can be erased.

Use the following procedure to erase a byte, block or the entire EEPROM array:

1. Configure EERAS1 and EERAS0 for byte, block or bulk erase; set EELAT in EECR.^(A)

NOTE: If using the AUTO mode, also set the AUTO bit in Step 1.

2. Byte erase: write any data to the desired address.^(B)

Block erase: write any data to an address within the desired block.^(B)

Bulk erase: write any data to an address within the array.^(B)

3. Set the EEPGM bit.^(C) Go to Step 7 if AUTO is set.

4. Wait for a time: t_{EEBYTE} for byte erase; $t_{EEBLOCK}$ for block erase; t_{EEBULK} for bulk erase.
5. Clear EEPGM bit.
6. Wait for a time, t_{EEFPV} , for the erasing voltage to fall. Go to Step 8.
7. Poll the EEPGM bit until it is cleared by the internal timer.^(D)
8. Clear EELAT bits.^(E)

NOTE: **A.** Setting the EELAT bit configures the address and data buses to latch data for erasing the array. Only valid EEPROM addresses will be latched. If EELAT is set, other writes to the EECR will be allowed after a valid EEPROM write.

B. If more than one valid EEPROM write occurs, the last address and data will be latched overriding the previous address and data. Once data is written to the desired address, do not read EEPROM locations other than the written location. (Reading an EEPROM location returns the latched data and causes the read address to be latched).

C. The EEPGM bit cannot be set if the EELAT bit is cleared or a non-valid EEPROM address is latched. This is to ensure proper programming sequence. Once EEPGM is set, do not read any EEPROM locations; otherwise, the current program cycle will be unsuccessful. When EEPGM is set, the on-board programming sequence will be activated.

D. The delay time for the EEPGM bit to be cleared in AUTO mode is less than $t_{EEBYTE}/t_{EEBLOCK}/t_{EEBULK}$. However, on other MCUs, this delay time may be different. For forward compatibility, software should not make any dependency on this delay time.

E. Any attempt to clear both EEPGM and EELAT bits with a single instruction will only clear EEPGM. This is to allow time for removal of high voltage from the EEPROM array.

5.6 EEPROM Register Descriptions

Four I/O registers and three non-volatile registers control program, erase and options of the EEPROM array.

5.6.1 EEPROM Control Register

This read/write register controls programming/erasing of the array.

Address: \$FE1D

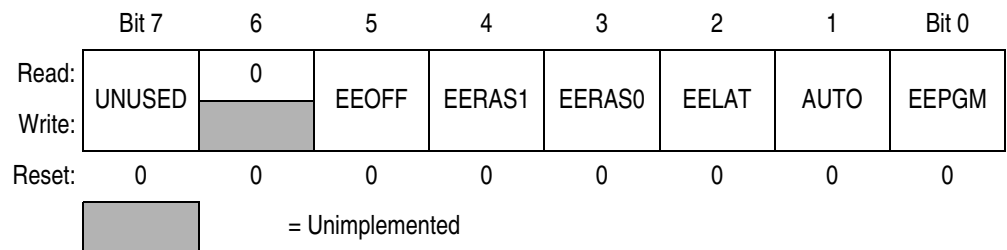

Figure 5-2. EEPROM Control Register (ECCR)

Bit 7— Unused bit

This read/write bit is software programmable but has no functionality.

EEOFF — EEPROM power down

This read/write bit disables the EEPROM module for lower power consumption. Any attempts to access the array will give unpredictable results. Reset clears this bit.

1 = Disable EEPROM array

0 = Enable EEPROM array

EERAS1 and EERAS0 — Erase/Program Mode Select Bits

These read/write bits set the erase modes. Reset clears these bits.

Table 5-3. EEPROM Program/Erase Mode Select

EEBPx	EERAS1	EERAS0	MODE
0	0	0	Byte Program
0	0	1	Byte Erase
0	1	0	Block Erase
0	1	1	Bulk Erase
1	X	X	No Erase/Program

X = don't care

EELAT — EEPROM Latch Control

This read/write bit latches the address and data buses for programming the EEPROM array. EELAT cannot be cleared if EEPGM is still set. Reset clears this bit.

- 1 = Buses configured for EEPROM programming or erase operation
- 0 = Buses configured for normal operation

AUTO — Automatic termination of program/erase cycle

When AUTO is set, EEPGM is cleared automatically after the program/erase cycle is terminated by the internal timer.

(See note D for [EEPROM Programming](#) on page 70, [EEPROM Erasing](#) on page 71 and [EEPROM Memory Characteristics](#) on page 430)

- 1 = Automatic clear of EEPGM is enabled
- 0 = Automatic clear of EEPGM is disabled

EEPGM — EEPROM Program/Erase Enable

This read/write bit enables the internal charge pump and applies the programming/erasing voltage to the EEPROM array if the EELAT bit is set and a write to a valid EEPROM location has occurred. Reset clears the EEPGM bit.

- 1 = EEPROM programming/erasing power switched on
- 0 = EEPROM programming/erasing power switched off

NOTE: *Writing logic 0s to both the EELAT and EEPGM bits with a single instruction will clear EEPGM only to allow time for the removal of high voltage.*

5.6.2 EEPROM Array Configuration Register

The EEPROM array configuration register configures EEPROM security and EEPROM block protection.

This read-only register is loaded with the contents of the EEPROM non-volatile register (EENVR) after a reset.

Address: \$FE1F

	Bit 7	6	5	4	3	2	1	Bit 0
Read:	UNUSED	UNUSED	UNUSED	EEPRTCT	EEBP3	EEBP2	EEBP1	EEBP0
Write:								
Reset:	Contents of EENVR (\$FE1C)							

Figure 5-3. EEPROM Array Configuration Register (EEACR)

Bit 7:5 — Unused Bits

These read/write bits are software programmable but have no functionality.

EEPRTCT — EEPROM Protection Bit

The EEPRTCT bit is used to enable the security feature in the EEPROM (see [EEPROM Program/Erase Protection](#)).

1 = EEPROM security disabled

0 = EEPROM security enabled

This feature is a write-once feature. Once the protection is enabled it may not be disabled.

EEBP[3:0] — EEPROM Block Protection Bits

These bits prevent blocks of EEPROM array from being programmed or erased.

1 = EEPROM array block is protected

0 = EEPROM array block is unprotected

Block Number (EEBPx)	Address Range
EEBP0	\$0800–\$087F
EEBP1	\$0880–\$08FF
EEBP2	\$0900–\$097F
EEBP3	\$0980–\$09FF

Table 5-4. EEPROM Block Protect and Security Summary

Address Range	EEBPx	EEPRTCT = 1	EEPRTCT = 0
\$0800 - \$087F	EEBP0 = 0	Byte Programming Available Bulk, Block and Byte Erasing Available	Byte Programming Available Only Byte Erasing Available
	EEBP0 = 1	Protected	Protected
\$0880 - \$08EF	EEBP1 = 0	Byte Programming Available Bulk, Block and Byte Erasing Available	Byte Programming Available Only Byte Erasing Available
	EEBP1 = 1	Protected	Protected
\$08F0 - \$08FF	EEBP1 = 0	Byte Programming Available Bulk, Block and Byte Erasing Available	Secured (No Programming or Erasing)
	EEBP1 = 1	Protected	
\$0900 - \$097F	EEBP2 = 0	Byte Programming Available Bulk, Block and Byte Erasing Available	Byte Programming Available Only Byte Erasing Available
	EEBP2 = 1	Protected	Protected
\$0980 - \$09FF	EEBP3 = 0	Byte Programming Available Bulk, Block and Byte Erasing Available	Byte Programming Available Only Byte Erasing Available
	EEBP3 = 1	Protected	Protected

5.6.3 EEPROM Nonvolatile Register

The contents of this register is loaded into the EEPROM array configuration register (EEACR) after a reset.

This register is erased and programmed in the same way as an EEPROM byte. (See [EEPROM Control Register](#) on page 73 for individual bit descriptions).

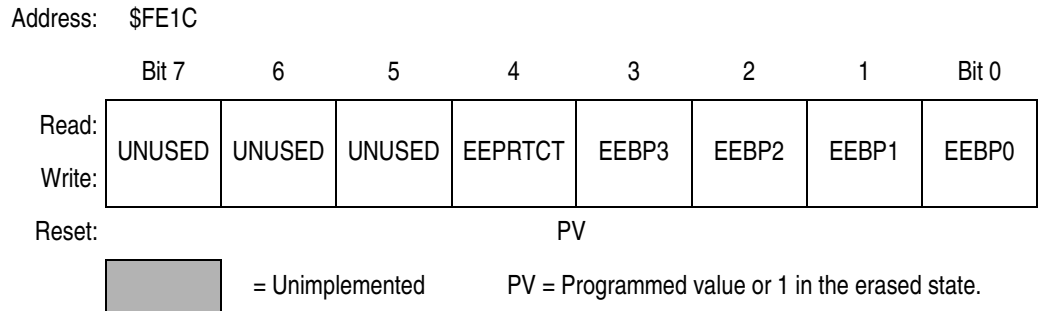

Figure 5-4. EEPROM Nonvolatile Register (EENVR)

NOTE: *The EENVR will leave the factory programmed with \$F0 such that the full array is available and unprotected.*

5.6.4 EEPROM Timebase Divider Register

The 16-bit EEPROM timebase divider register consists of two 8-bit registers: EEDIVH and EEDIVL. The 11-bit value in this register is used to configure the timebase divider circuit to obtain the 35 μ s timebase for EEPROM control.

These two read/write registers are respectively loaded with the contents of the EEPROM timebase divider on-volatile registers (EEDIVHNVR and EEDIVLNVR) after a reset.

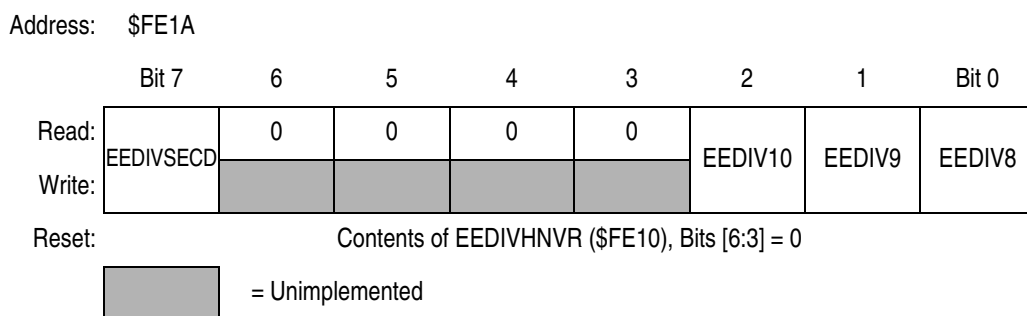

Figure 5-5. EEDIV Divider High Register (EEDIVH)

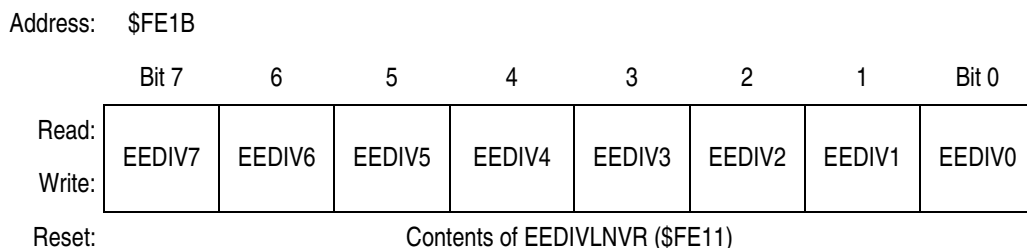

Figure 5-6. EEDIV Divider Low Register (EEDIVL)

EEDIVSECD — EEPROM Divider Security Disable

This bit enables/disables the security feature of the EEDIV registers. When EEDIV security feature is enabled, the state of the registers EEDIVH and EEDIVL are locked (including EEDIVSECD bit). The EEDIVHNVR and EEDIVLNVR non-volatile memory registers are also protected from being erased/programmed.

1 = EEDIV security feature disabled

0 = EEDIV security feature enabled

EEDIV[10:0] — EEPROM timebase prescaler

These prescaler bits store the value of EEDIV which is used as the divisor to derive a timebase of 35 μ s from the selected reference clock source (CGMXCLK or bus block in the CONFIG-2 register) for the EEPROM related internal timer and circuits. EEDIV[10:0] bits are readable at any time. They are writable when EELAT = 0 and EEDIVSECD = 1.

The EEDIV value is calculated by the following formula:

$$EEDIV = \text{INT}[\text{Reference Frequency(Hz)} \times 35 \times 10^{-6} + 0.5]$$

Where the result inside the bracket is rounded down to the nearest integer value

For example, if the reference frequency is 4.9152MHz, the EEDIV value is 172

NOTE: *Programming/erasing the EEPROM with an improper EEDIV value may result in data lost and reduce endurance of the EEPROM device.*

5.6.5 EEPROM Timebase Divider Non-Volatile Register

The 16-bit EEPROM timebase divider non-volatile register consists of two 8-bit registers: EEDIVHNVR and EEDIVLNVR. The contents of these two registers are respectively loaded into the EEPROM timebase divider registers, EEDIVH and EEDIVL, after a reset.

These two registers are erased and programmed in the same way as an EEPROM byte.

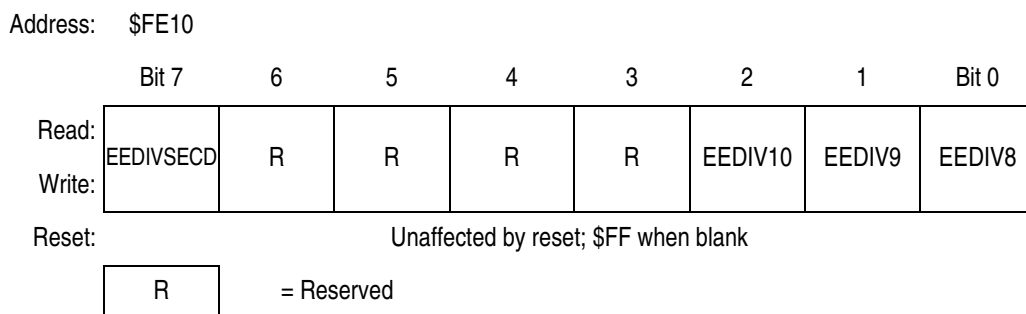

Figure 5-7. EEPROM Divider Non-Volatile Register High (EEDIVHNVR)

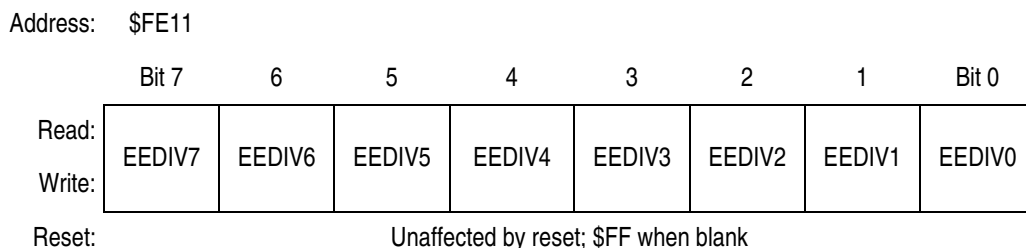

Figure 5-8. EEPROM Divider Non-Volatile Register Low (EEDIVLNVR)

These two registers are protected from erase and program operations if the EEDIVSECD is set to logic 1 in the EEDIVH (see [EEPROM Timebase Divider Register](#)) or programmed to a logic 1 in the EEDIVHNVR.

NOTE: *Once EEDIVSECD in the EEDIVHNVR is programmed to 0 and after a system reset, the EEDIV security feature is permanently enabled because the EEDIVSECD bit in the EEDIVH is always loaded with 0*

thereafter. Once this security feature is armed, erase and program mode are disabled for EEDIVHNVR and EEDIVLNVR. Modifications to the EEDIVH and EEDIVL registers are also disabled. Therefore, care should be taken before programming a value into the EEDIVHNVR.

5.7 Low-Power Modes

The WAIT and STOP instructions can put the MCU in low power-consumption standby modes.

5.7.1 Wait Mode

The WAIT instruction does not affect the EEPROM. It is possible to start the program or erase sequence on the EEPROM and put the MCU in wait mode.

5.7.2 Stop Mode

The STOP instruction reduces the EEPROM power consumption to a minimum. The STOP instruction should not be executed while a programming or erasing sequence is in progress.

If stop mode is entered while EELAT and EEPGM are set, the programming sequence will be stopped and the programming voltage to the EEPROM array removed. The programming sequence will be restarted after leaving stop mode; access to the EEPROM is only possible after the programming sequence has completed.

If stop mode is entered while EELAT and EEPGM is cleared, the programming sequence will be terminated abruptly.

In either case, the data integrity of the EEPROM is not guaranteed.

Section 6. Central Processor Unit (CPU)

6.1 Contents

6.2	Introduction	83
6.3	Features	84
6.4	CPU registers	84
6.4.1	Accumulator (A)	85
6.4.2	Index register (H:X)	85
6.4.3	Stack pointer (SP)	86
6.4.4	Program counter (PC)	86
6.4.5	Condition code register (CCR)	87
6.5	Arithmetic/logic unit (ALU)	89
6.6	Low-power modes	90
6.6.1	WAIT mode	90
6.6.2	STOP mode	90
6.7	CPU during break interrupts	90
6.8	Instruction Set Summary	91
6.9	Opcode Map	99

6.2 Introduction

This section describes the central processor unit (CPU8). The M68HC08 CPU is an enhanced and fully object-code-compatible version of the M68HC05 CPU. The *CPU08 Reference Manual* (Motorola document number CPU08RM/AD) contains a description of the CPU instruction set, addressing modes, and architecture.

6.3 Features

Features of the CPU include the following:

- Full upward, object-code compatibility with M68HC05 family
- 16-bit stack pointer with stack manipulation instructions
- 16-bit index register with X-register manipulation instructions
- 8.4MHz CPU internal bus frequency
- 64K byte program/data memory space
- 16 addressing modes
- Memory-to-memory data moves without using accumulator
- Fast 8-bit by 8-bit multiply and 16-bit by 8-bit divide instructions
- Enhanced binary-coded decimal (BCD) data handling
- Low-power STOP and WAIT Modes

6.4 CPU registers

Figure 6-1 shows the five CPU registers. CPU registers are not part of the memory map.

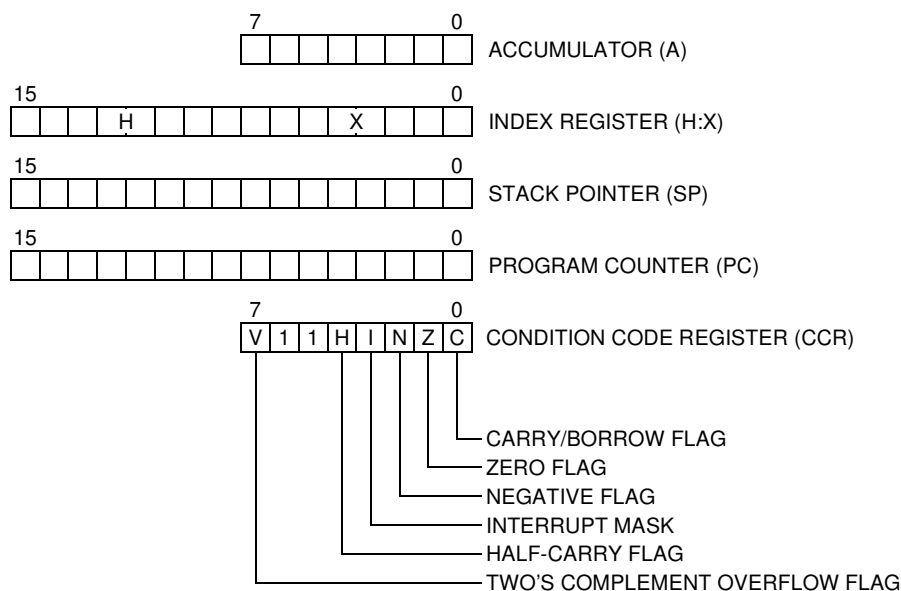

Figure 6-1. CPU registers

6.4.1 Accumulator (A)

The accumulator is a general-purpose 8-bit register. The CPU uses the accumulator to hold operands and the results of arithmetic/logic operations.

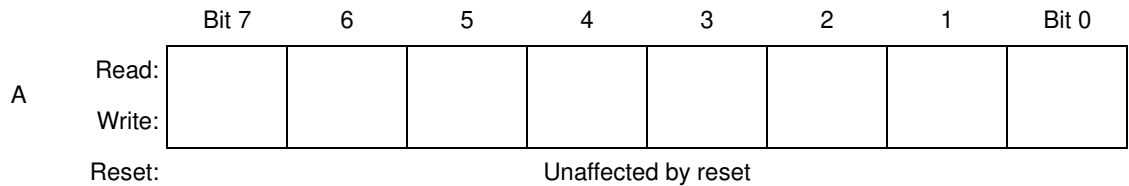

Figure 6-2. Accumulator (A)

6.4.2 Index register (H:X)

The 16-bit index register allows indexed addressing of a 64K byte memory space. H is the upper byte of the index register and X is the lower byte. H:X is the concatenated 16-bit index register.

In the indexed addressing modes, the CPU uses the contents of the index register to determine the conditional address of the operand.

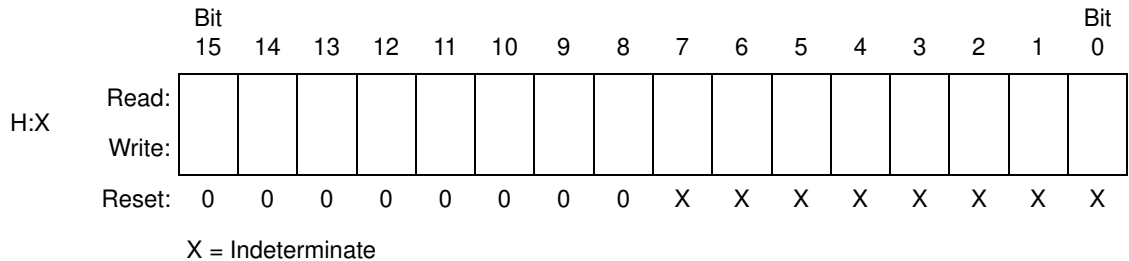

Figure 6-3. Index register (H:X)

The index register can also be used as a temporary data storage location.

6.4.3 Stack pointer (SP)

The stack pointer is a 16-bit register that contains the address of the next location on the stack. During a reset, the stack pointer is preset to \$00FF. The reset stack pointer (RSP) instruction sets the least significant byte to \$FF and does not affect the most significant byte. The stack pointer decrements as data is pushed onto the stack and increments as data is pulled from the stack.

In the stack pointer 8-bit offset and 16-bit offset addressing modes, the stack pointer can function as an index register to access data on the stack. The CPU uses the contents of the stack pointer to determine the conditional address of the operand.

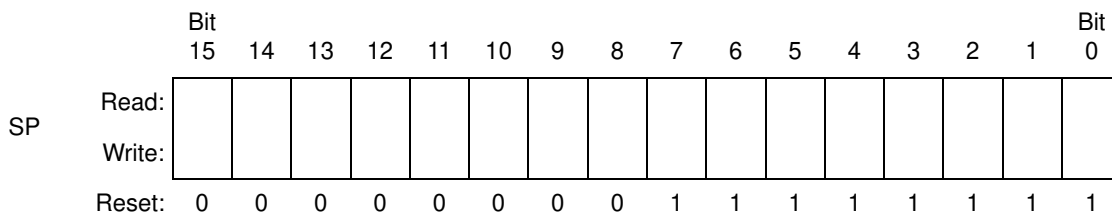

Figure 6-4. Stack pointer (SP)

NOTE: *The location of the stack is arbitrary and may be relocated anywhere in RAM. Moving the SP out of page zero (\$0000 to \$00FF) frees direct address (page zero) space. For correct operation, the stack pointer must point only to RAM locations.*

6.4.4 Program counter (PC)

The program counter is a 16-bit register that contains the address of the next instruction or operand to be fetched.

Normally, the program counter automatically increments to the next sequential memory location every time an instruction or operand is fetched. Jump, branch, and interrupt operations load the program counter with an address other than that of the next sequential location.

During reset, the program counter is loaded with the reset vector address located at \$FFFE and \$FFFF. The vector address is the address of the first instruction to be executed after exiting the reset state.

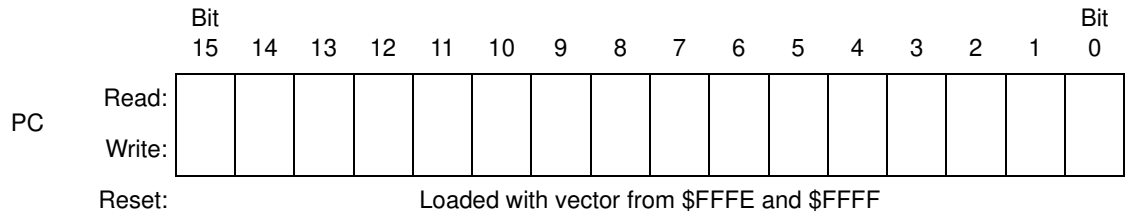

Figure 6-5. Program counter (PC)

6.4.5 Condition code register (CCR)

The 8-bit condition code register contains the interrupt mask and five flags that indicate the results of the instruction just executed. Bits 6 and 5 are set permanently to '1'. The following paragraphs describe the functions of the condition code register.

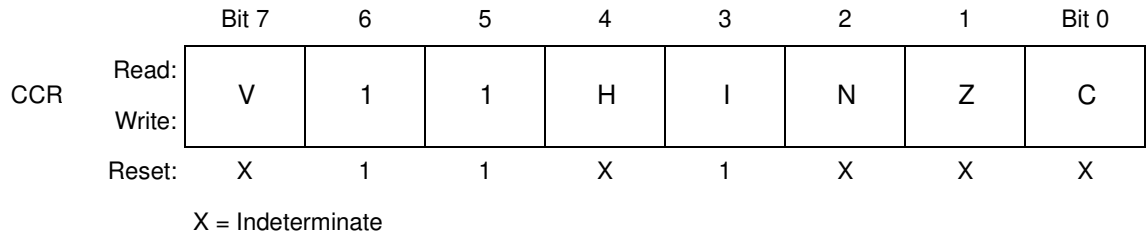

Figure 6-6. Condition code register (CCR)

V — Overflow flag

The CPU sets the overflow flag when a two's complement overflow occurs. The signed branch instructions BGT, BGE, BLE, and BLT use the overflow flag.

- 1 = Overflow
- 0 = No overflow

H — Half-carry flag

The CPU sets the half-carry flag when a carry occurs between accumulator bits 3 and 4 during an ADD or ADC operation. The half-carry flag is required for binary-coded decimal (BCD) arithmetic operations. The DAA instruction uses the states of the H and C flags to determine the appropriate correction factor.

1 = Carry between bits 3 and 4

0 = No carry between bits 3 and 4

I — Interrupt mask

When the interrupt mask is set, all maskable CPU interrupts are disabled. CPU interrupts are enabled when the interrupt mask is cleared. When a CPU interrupt occurs, the interrupt mask is set automatically after the CPU registers are saved on the stack, but before the interrupt vector is fetched.

1 = Interrupts disabled

0 = Interrupts enabled

NOTE: *To maintain M6805 compatibility, the upper byte of the index register (H) is not stacked automatically. If the interrupt service routine modifies H, then the user must stack and unstack H using the PSHH and PULH instructions.*

After the I bit is cleared, the highest-priority interrupt request is serviced first.

A return from interrupt (RTI) instruction pulls the CPU registers from the stack and restores the interrupt mask from the stack. After any reset, the interrupt mask is set and can only be cleared by the clear interrupt mask software instruction (CLI).

N — Negative flag

The CPU sets the negative flag when an arithmetic operation, logic operation, or data manipulation produces a negative result, setting bit 7 of the result.

- 1 = Negative result
- 0 = Non-negative result

Z — Zero flag

The CPU sets the zero flag when an arithmetic operation, logic operation, or data manipulation produces a result of \$00.

- 1 = Zero result
- 0 = Non-zero result

C — Carry/borrow flag

The CPU sets the carry/borrow flag when an addition operation produces a carry out of bit 7 of the accumulator or when a subtraction operation requires a borrow. Some instructions - such as bit test and branch, shift, and rotate - also clear or set the carry/borrow flag.

- 1 = Carry out of bit 7
- 0 = No carry out of bit 7

6.5 Arithmetic/logic unit (ALU)

The ALU performs the arithmetic and logic operations defined by the instruction set.

Refer to the *CPU08 Reference Manual* (Motorola document number CPU08RM/AD) for a description of the instructions and addressing modes and more detail about CPU architecture.

6.6 Low-power modes

The WAIT and STOP instructions put the MCU in low-power consumption standby modes.

6.6.1 WAIT mode

The WAIT instruction:

- clears the interrupt mask (I bit) in the condition code register, enabling interrupts. After exit from WAIT mode by interrupt, the I bit remains clear. After exit by reset, the I bit is set.
- Disables the CPU clock

6.6.2 STOP mode

The STOP instruction:

- clears the interrupt mask (I bit) in the condition code register, enabling external interrupts. After exit from STOP mode by external interrupt, the I bit remains clear. After exit by reset, the I bit is set.
- Disables the CPU clock

After exiting STOP mode, the CPU clock begins running after the oscillator stabilization delay.

6.7 CPU during break interrupts

If the break module is enabled, a break interrupt causes the CPU to execute the software interrupt instruction (SWI) at the completion of the current CPU instruction. See [Break Module \(BRK\)](#). The program counter vectors to \$FFFC–\$FFFD (\$FEFC–\$FEFD in monitor mode).

A return-from-interrupt instruction (RTI) in the break routine ends the break interrupt and returns the MCU to normal operation if the break interrupt has been deasserted.

6.8 Instruction Set Summary

Table 6-1 provides a summary of the M68HC08 instruction set.

Table 6-1. Instruction Set Summary

Source Form	Operation	Description	Effect on CCR					Address Mode	Opcode	Operand	Cycles	
			V	H	I	N	Z					C
ADC #opr ADC opr ADC opr ADC opr,X ADC opr,X ADC ,X ADC opr,SP ADC opr,SP	Add with Carry	$A \leftarrow (A) + (M) + (C)$	↑	↑	-	↑	↑	↑	IMM DIR EXT IX2 IX1 IX SP1 SP2	A9 B9 C9 D9 E9 F9 9E E9 9E D9	ii dd hh ll ee ff ff ff ff ff	2 3 4 4 3 2 4 5
ADD #opr ADD opr ADD opr ADD opr,X ADD opr,X ADD ,X ADD opr,SP ADD opr,SP	Add without Carry	$A \leftarrow (A) + (M)$	↑	↑	-	↑	↑	↑	IMM DIR EXT IX2 IX1 IX SP1 SP2	AB BB CB DB EB FB 9E EB 9E DB	ii dd hh ll ee ff ff ff ff ff	2 3 4 4 3 2 4 5
AIS #opr	Add Immediate Value (Signed) to SP	$SP \leftarrow (SP) + (16 \ll M)$	-	-	-	-	-	-	IMM	A7	ii	2
AIX #opr	Add Immediate Value (Signed) to H:X	$H:X \leftarrow (H:X) + (16 \ll M)$	-	-	-	-	-	-	IMM	AF	ii	2
AND #opr AND opr AND opr AND opr,X AND opr,X AND ,X AND opr,SP AND opr,SP	Logical AND	$A \leftarrow (A) \& (M)$	0	-	-	↑	↑	-	IMM DIR EXT IX2 IX1 IX SP1 SP2	A4 B4 C4 D4 E4 F4 9E E4 9E D4	ii dd hh ll ee ff ff ff ff ff	2 3 4 4 3 2 4 5
ASL opr ASLA ASLX ASL opr,X ASL ,X ASL opr,SP	Arithmetic Shift Left (Same as LSL)		↑	-	-	↑	↑	↑	DIR INH INH IX1 IX SP1	38 48 58 68 78 9E 68	dd ff ff	4 1 1 4 3 5
ASR opr ASRA ASRX ASR opr,X ASR opr,X ASR opr,SP	Arithmetic Shift Right		↑	-	-	↑	↑	↑	DIR INH INH IX1 IX SP1	37 47 57 67 77 9E 67	dd ff ff	4 1 1 4 3 5

Table 6-1. Instruction Set Summary (Continued)

Source Form	Operation	Description	Effect on CCR						Address Mode	Opcode	Operand	Cycles
			V	H	I	N	Z	C				
BCC <i>rel</i>	Branch if Carry Bit Clear	$PC \leftarrow (PC) + 2 + rel ? (C) = 0$	-	-	-	-	-	-	REL	24	rr	3
BCLR <i>n, opr</i>	Clear Bit <i>n</i> in <i>M</i>	$M_n \leftarrow 0$	-	-	-	-	-	-	DIR (b0) DIR (b1) DIR (b2) DIR (b3) DIR (b4) DIR (b5) DIR (b6) DIR (b7)	11 13 15 17 19 1B 1D 1F	dd dd dd dd dd dd dd	4 4 4 4 4 4 4 4
BCS <i>rel</i>	Branch if Carry Bit Set (Same as BLO)	$PC \leftarrow (PC) + 2 + rel ? (C) = 1$	-	-	-	-	-	-	REL	25	rr	3
BEQ <i>rel</i>	Branch if Equal	$PC \leftarrow (PC) + 2 + rel ? (Z) = 1$	-	-	-	-	-	-	REL	27	rr	3
BGE <i>opr</i>	Branch if Greater Than or Equal To (Signed Operands)	$PC \leftarrow (PC) + 2 + rel ? (N \oplus V) = 0$	-	-	-	-	-	-	REL	90	rr	3
BGT <i>opr</i>	Branch if Greater Than (Signed Operands)	$PC \leftarrow (PC) + 2 + rel ? (Z) (N \oplus V) = 0$	-	-	-	-	-	-	REL	92	rr	3
BHCC <i>rel</i>	Branch if Half Carry Bit Clear	$PC \leftarrow (PC) + 2 + rel ? (H) = 0$	-	-	-	-	-	-	REL	28	rr	3
BHCS <i>rel</i>	Branch if Half Carry Bit Set	$PC \leftarrow (PC) + 2 + rel ? (H) = 1$	-	-	-	-	-	-	REL	29	rr	3
BHI <i>rel</i>	Branch if Higher	$PC \leftarrow (PC) + 2 + rel ? (C) (Z) = 0$	-	-	-	-	-	-	REL	22	rr	3
BHS <i>rel</i>	Branch if Higher or Same (Same as BCC)	$PC \leftarrow (PC) + 2 + rel ? (C) = 0$	-	-	-	-	-	-	REL	24	rr	3
BIH <i>rel</i>	Branch if \overline{IRQ} Pin High	$PC \leftarrow (PC) + 2 + rel ? \overline{IRQ} = 1$	-	-	-	-	-	-	REL	2F	rr	3
BIL <i>rel</i>	Branch if \overline{IRQ} Pin Low	$PC \leftarrow (PC) + 2 + rel ? \overline{IRQ} = 0$	-	-	-	-	-	-	REL	2E	rr	3
BIT # <i>opr</i> BIT <i>opr</i> BIT <i>opr</i> BIT <i>opr</i> , <i>X</i> BIT <i>opr</i> , <i>X</i> BIT , <i>X</i> BIT <i>opr</i> , <i>SP</i> BIT <i>opr</i> , <i>SP</i>	Bit Test	(<i>A</i>) & (<i>M</i>)	0	-	-	↕	↕	-	IMM DIR EXT IX2 IX1 IX SP1 SP2	A5 B5 C5 D5 E5 F5 9E E5 9E D5	ii dd hh ll ee ff ff ff ff ff ff	2 3 4 4 4 3 2 4 5
BLE <i>opr</i>	Branch if Less Than or Equal To (Signed Operands)	$PC \leftarrow (PC) + 2 + rel ? (Z) (N \oplus V) = 1$	-	-	-	-	-	-	REL	93	rr	3
BLO <i>rel</i>	Branch if Lower (Same as BCS)	$PC \leftarrow (PC) + 2 + rel ? (C) = 1$	-	-	-	-	-	-	REL	25	rr	3
BLS <i>rel</i>	Branch if Lower or Same	$PC \leftarrow (PC) + 2 + rel ? (C) (Z) = 1$	-	-	-	-	-	-	REL	23	rr	3
BLT <i>opr</i>	Branch if Less Than (Signed Operands)	$PC \leftarrow (PC) + 2 + rel ? (N \oplus V) = 1$	-	-	-	-	-	-	REL	91	rr	3

Table 6-1. Instruction Set Summary (Continued)

Source Form	Operation	Description	Effect on CCR						Address Mode	Opcode	Operand	Cycles
			V	H	I	N	Z	C				
BMC <i>rel</i>	Branch if Interrupt Mask Clear	$PC \leftarrow (PC) + 2 + rel ? (I) = 0$	-	-	-	-	-	-	REL	2C	rr	3
BMI <i>rel</i>	Branch if Minus	$PC \leftarrow (PC) + 2 + rel ? (N) = 1$	-	-	-	-	-	-	REL	2B	rr	3
BMS <i>rel</i>	Branch if Interrupt Mask Set	$PC \leftarrow (PC) + 2 + rel ? (I) = 1$	-	-	-	-	-	-	REL	2D	rr	3
BNE <i>rel</i>	Branch if Not Equal	$PC \leftarrow (PC) + 2 + rel ? (Z) = 0$	-	-	-	-	-	-	REL	26	rr	3
BPL <i>rel</i>	Branch if Plus	$PC \leftarrow (PC) + 2 + rel ? (N) = 0$	-	-	-	-	-	-	REL	2A	rr	3
BRA <i>rel</i>	Branch Always	$PC \leftarrow (PC) + 2 + rel$	-	-	-	-	-	-	REL	20	rr	3
BRCLR <i>n,opr,rel</i>	Branch if Bit <i>n</i> in M Clear	$PC \leftarrow (PC) + 3 + rel ? (Mn) = 0$	-	-	-	-	-	↓	DIR (b0)	01	dd	5
									DIR (b1)		rr	
									DIR (b2)		dd	
									DIR (b3)		rr	
									DIR (b4)		dd	
									DIR (b5)		rr	
									DIR (b6)		dd	
									DIR (b7)		rr	
BRN <i>rel</i>	Branch Never	$PC \leftarrow (PC) + 2$	-	-	-	-	-	-	REL	21	rr	3
BRSET <i>n,opr,rel</i>	Branch if Bit <i>n</i> in M Set	$PC \leftarrow (PC) + 3 + rel ? (Mn) = 1$	-	-	-	-	-	↓	DIR (b0)	00	dd	5
									DIR (b1)		rr	
									DIR (b2)		dd	
									DIR (b3)		rr	
									DIR (b4)		dd	
									DIR (b5)		rr	
									DIR (b6)		dd	
									DIR (b7)		rr	
BSET <i>n,opr</i>	Set Bit <i>n</i> in M	$Mn \leftarrow 1$	-	-	-	-	-	-	DIR (b0)	10	dd	4
									DIR (b1)		dd	
									DIR (b2)		dd	
									DIR (b3)		dd	
									DIR (b4)		dd	
									DIR (b5)		dd	
									DIR (b6)		dd	
									DIR (b7)		dd	

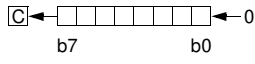
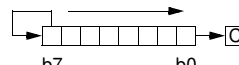
Table 6-1. Instruction Set Summary (Continued)

Source Form	Operation	Description	Effect on CCR						Address Mode	Opcode	Operand	Cycles
			V	H	I	N	Z	C				
BSR <i>rel</i>	Branch to Subroutine	PC ← (PC) + 2; push (PCL) SP ← (SP) - 1; push (PCH) SP ← (SP) - 1 PC ← (PC) + <i>rel</i>	-	-	-	-	-	-	REL	AD	rr	4
CBEQ <i>opr,rel</i> CBEQA # <i>opr,rel</i> CBEQX # <i>opr,rel</i> CBEQ <i>opr,X+,rel</i> CBEQ <i>X+,rel</i> CBEQ <i>opr,SP,rel</i>	Compare and Branch if Equal	PC ← (PC) + 3 + <i>rel</i> ? (A) - (M) = \$00 PC ← (PC) + 3 + <i>rel</i> ? (A) - (M) = \$00 PC ← (PC) + 3 + <i>rel</i> ? (X) - (M) = \$00 PC ← (PC) + 3 + <i>rel</i> ? (A) - (M) = \$00 PC ← (PC) + 2 + <i>rel</i> ? (A) - (M) = \$00 PC ← (PC) + 4 + <i>rel</i> ? (A) - (M) = \$00	-	-	-	-	-	-	DIR IMM IMM IX1+ IX+ SP1	31 41 51 61 71 9E 61	dd rr ii rr ii rr ff rr rr rr ff rr	5 4 4 4 5 4 6
CLC	Clear Carry Bit	C ← 0	-	-	-	-	-	0	INH	98		1
CLI	Clear Interrupt Mask	I ← 0	-	-	0	-	-	-	INH	9A		2
CLR <i>opr</i> CLRA CLR X CLR H CLR <i>opr,X</i> CLR ,X CLR <i>opr,SP</i>	Clear	M ← \$00 A ← \$00 X ← \$00 H ← \$00 M ← \$00 M ← \$00 M ← \$00	0	-	-	0	1	-	DIR INH INH INH IX1 IX SP1	3F 4F 5F 8C 6F 7F 9E 6F	dd ff ff ff	3 1 1 1 3 2 4
CMP # <i>opr</i> CMP <i>opr</i> CMP <i>opr</i> CMP <i>opr,X</i> CMP <i>opr,X</i> CMP ,X CMP <i>opr,SP</i> CMP <i>opr,SP</i>	Compare A with M	(A) - (M)	↑	-	-	↑	↑	↑	IMM DIR EXT IX2 IX1 IX SP1 SP2	A1 B1 C1 D1 E1 F1 9E E1 9E D1	ii dd hh ll ee ff ff ff ff ff ff ee ff ff	2 3 4 4 3 2 4 5
COM <i>opr</i> COMA COM X COM <i>opr,X</i> COM ,X COM <i>opr,SP</i>	Complement (One's Complement)	M ← (M) = \$FF - (M) A ← (A) = \$FF - (M) X ← (X) = \$FF - (M) M ← (M) = \$FF - (M) M ← (M) = \$FF - (M) M ← (M) = \$FF - (M)	0	-	-	↑	↑	1	DIR INH INH IX1 IX SP1	33 43 53 63 73 9E 63	dd ff ff	4 1 1 4 3 5
CPHX # <i>opr</i> CPHX <i>opr</i>	Compare H:X with M	(H:X) - (M:M + 1)	↑	-	-	↑	↑	↑	IMM DIR	65 75	ii ii+1 dd	3 4
CPX # <i>opr</i> CPX <i>opr</i> CPX <i>opr</i> CPX ,X CPX <i>opr,X</i> CPX <i>opr,X</i> CPX <i>opr,SP</i> CPX <i>opr,SP</i>	Compare X with M	(X) - (M)	↑	-	-	↑	↑	↑	IMM DIR EXT IX2 IX1 IX SP1 SP2	A3 B3 C3 D3 E3 F3 9E E3 9E D3	ii dd hh ll ee ff ff ff ff ff ff ee ff ff	2 3 4 4 3 2 4 5

Table 6-1. Instruction Set Summary (Continued)

Source Form	Operation	Description	Effect on CCR						Address Mode	Opcode	Operand	Cycles
			V	H	I	N	Z	C				
DAA	Decimal Adjust A	$(A)_{10}$	U	-	-	↑	↑	↓	INH	72		2
DBNZ <i>opr,rel</i> DBNZA <i>rel</i> DBNZX <i>rel</i> DBNZ <i>opr,X,rel</i> DBNZ <i>X,rel</i> DBNZ <i>opr,SP,rel</i>	Decrement and Branch if Not Zero	$A \leftarrow (A) - 1$ or $M \leftarrow (M) - 1$ or $X \leftarrow (X) - 1$ $PC \leftarrow (PC) + 3 + rel ? (result) \neq 0$ $PC \leftarrow (PC) + 2 + rel ? (result) \neq 0$ $PC \leftarrow (PC) + 2 + rel ? (result) \neq 0$ $PC \leftarrow (PC) + 3 + rel ? (result) \neq 0$ $PC \leftarrow (PC) + 2 + rel ? (result) \neq 0$ $PC \leftarrow (PC) + 4 + rel ? (result) \neq 0$							DIR INH INH IX1 IX SP1	3B 4B 5B 6B 7B 9E 6B	dd rr rr rr ff rr rr ff rr	5 3 3 5 4 6
DEC <i>opr</i> DECA DECX DEC <i>opr,X</i> DEC <i>,X</i> DEC <i>opr,SP</i>	Decrement	$M \leftarrow (M) - 1$ $A \leftarrow (A) - 1$ $X \leftarrow (X) - 1$ $M \leftarrow (M) - 1$ $M \leftarrow (M) - 1$ $M \leftarrow (M) - 1$	↑			↑	↓		DIR INH INH IX1 IX SP1	3A 4A 5A 6A 7A 9E 6A	dd ff ff	4 1 1 4 3 5
DIV	Divide	$A \leftarrow (H:A)/(X)$ $H \leftarrow \text{Remainder}$					↑	↓	INH	52		7
EOR # <i>opr</i> EOR <i>opr</i> EOR <i>opr</i> EOR <i>opr,X</i> EOR <i>opr,X</i> EOR <i>,X</i> EOR <i>opr,SP</i> EOR <i>opr,SP</i>	Exclusive OR M with A	$A \leftarrow (A \oplus M)$	0			↑	↓		IMM DIR EXT IX2 IX1 IX SP1 SP2	A8 B8 C8 D8 E8 F8 9E E8 9E D8	ii dd hh ll ll ee ff ff ff ff ee ff	2 3 4 4 3 2 4 5
INC <i>opr</i> INCA INCX INC <i>opr,X</i> INC <i>,X</i> INC <i>opr,SP</i>	Increment	$M \leftarrow (M) + 1$ $A \leftarrow (A) + 1$ $X \leftarrow (X) + 1$ $M \leftarrow (M) + 1$ $M \leftarrow (M) + 1$ $M \leftarrow (M) + 1$	↑			↑	↓		DIR INH INH IX1 IX SP1	3C 4C 5C 6C 7C 9E 6C	dd ff ff	4 1 1 4 3 5
JMP <i>opr</i> JMP <i>opr</i> JMP <i>opr,X</i> JMP <i>opr,X</i> JMP <i>,X</i>	Jump	$PC \leftarrow \text{Jump Address}$							DIR EXT IX2 IX1 IX	BC CC DC EC FC	dd hh ll ee ff ff ff	2 3 4 3 2
JSR <i>opr</i> JSR <i>opr</i> JSR <i>opr,X</i> JSR <i>opr,X</i> JSR <i>,X</i>	Jump to Subroutine	$PC \leftarrow (PC) + n (n = 1, 2, \text{ or } 3)$ Push (PCL); $SP \leftarrow (SP) - 1$ Push (PCH); $SP \leftarrow (SP) - 1$ $PC \leftarrow \text{Unconditional Address}$							DIR EXT IX2 IX1 IX	BD CD DD ED FD	dd hh ll ee ff ff ff	4 5 6 5 4

Table 6-1. Instruction Set Summary (Continued)

Source Form	Operation	Description	Effect on CCR					Address Mode	Opcode	Operand	Cycles	
			V	H	I	N	Z					C
LDA #opr LDA opr LDA opr,X LDA opr,X LDA ,X LDA opr,SP LDA opr,SP	Load A from M	$A \leftarrow (M)$	0	-	-	↑	↓	-	IMM DIR EXT IX2 IX1 IX SP1 SP2	A6 B6 C6 D6 E6 F6 9E E6 9E D6	ii dd hh ll ee ff ff ff ff ff	2 3 4 4 3 2 4 4 5
LDHX #opr LDHX opr	Load H:X from M	$H:X \leftarrow (M:M + 1)$	0	-	-	↑	↓	-	IMM DIR	45 55	ii jj dd	3 4
LDX #opr LDX opr LDX opr LDX opr,X LDX opr,X LDX ,X LDX opr,SP LDX opr,SP	Load X from M	$X \leftarrow (M)$	0	-	-	↑	↓	-	IMM DIR EXT IX2 IX1 IX SP1 SP2	AE BE CE DE EE FE 9E EE 9E DE	ii dd hh ll ee ff ff ff ff ff	2 3 4 4 3 2 4 4 5
LSL opr LSLA LSLX LSL opr,X LSL ,X LSL opr,SP	Logical Shift Left (Same as ASL)		↑	-	-	↑	↓	↓	DIR INH INH IX1 IX SP1	38 48 58 68 78 9E 68	dd ff ff	4 1 1 4 3 5
LSR opr LSRA LSRX LSR opr,X LSR ,X LSR opr,SP	Logical Shift Right		↓	-	0	↓	↓	↓	DIR INH INH IX1 IX SP1	34 44 54 64 74 9E 64	dd ff ff	4 1 1 4 3 5
MOV opr,opr MOV opr,X+ MOV #opr,opr MOV X+,opr	Move	$(M)_{\text{Destination}} \leftarrow (M)_{\text{Source}}$ $H:X \leftarrow (H:X) + 1$ (IX+D, DIX+)	0	-	-	↑	↓	-	DD DIX+ IMD IX+D	4E 5E 6E 7E	dd dd dd ii dd dd	5 4 4 4
MUL	Unsigned multiply	$X:A \leftarrow (X) \times (A)$	-	0	-	-	-	0	INH	42		5
NEG opr NEGA NEGX NEG opr,X NEG ,X NEG opr,SP	Negate (Two's Complement)	$M \leftarrow -(M) = \$00 - (M)$ $A \leftarrow -(A) = \$00 - (A)$ $X \leftarrow -(X) = \$00 - (X)$ $M \leftarrow -(M) = \$00 - (M)$ $M \leftarrow -(M) = \$00 - (M)$	↑	-	-	↓	↓	↓	DIR INH INH IX1 IX SP1	30 40 50 60 70 9E 60	dd ff ff	4 1 1 4 3 5
NOP	No Operation	None	-	-	-	-	-	-	INH	9D		1
NSA	Nibble Swap A	$A \leftarrow (A[3:0]:A[7:4])$	-	-	-	-	-	-	INH	62		3

Table 6-1. Instruction Set Summary (Continued)

Source Form	Operation	Description	Effect on CCR					Address Mode	Opcode	Operand	Cycles	
			V	H	I	N	Z					C
ORA #opr ORA opr ORA opr ORA opr,X ORA opr,X ORA ,X ORA opr,SP ORA opr,SP	Inclusive OR A and M	$A \leftarrow (A) (M)$	0	-	-	↑	↓	-	IMM DIR EXT IX2 IX1 IX SP1 SP2	AA BA CA DA EA FA 9E EA 9E DA	ii dd hh ll ee ff ff ff ff ee ff ff	2 3 4 4 3 2 4 5
PSHA	Push A onto Stack	Push (A); $SP \leftarrow (SP) - 1$	-	-	-	-	-	-	INH	87		2
PSHH	Push H onto Stack	Push (H); $SP \leftarrow (SP) - 1$	-	-	-	-	-	-	INH	8B		2
PSHX	Push X onto Stack	Push (X); $SP \leftarrow (SP) - 1$	-	-	-	-	-	-	INH	89		2
PULA	Pull A from Stack	$SP \leftarrow (SP + 1)$; Pull (A)	-	-	-	-	-	-	INH	86		2
PULH	Pull H from Stack	$SP \leftarrow (SP + 1)$; Pull (H)	-	-	-	-	-	-	INH	8A		2
PULX	Pull X from Stack	$SP \leftarrow (SP + 1)$; Pull (X)	-	-	-	-	-	-	INH	88		2
ROL opr ROLA ROLX ROL opr,X ROL ,X ROL opr,SP	Rotate Left through Carry		↑	-	-	↑	↓	↓	DIR INH INH IX1 IX SP1	39 49 59 69 79 9E 69	dd ff ff	4 1 1 4 3 5
ROR opr RORA RORX ROR opr,X ROR ,X ROR opr,SP	Rotate Right through Carry		↓	-	-	↓	↑	↑	DIR INH INH IX1 IX SP1	36 46 56 66 76 9E 66	dd ff ff	4 1 1 4 3 5
RSP	Reset Stack Pointer	$SP \leftarrow \$FF$	-	-	-	-	-	-	INH	9C		1
RTI	Return from Interrupt	$SP \leftarrow (SP) + 1$; Pull (CCR) $SP \leftarrow (SP) + 1$; Pull (A) $SP \leftarrow (SP) + 1$; Pull (X) $SP \leftarrow (SP) + 1$; Pull (PCH) $SP \leftarrow (SP) + 1$; Pull (PCL)	↑	↑	↑	↑	↑	↑	INH	80		7
RTS	Return from Subroutine	$SP \leftarrow SP + 1$; Pull (PCH) $SP \leftarrow SP + 1$; Pull (PCL)	-	-	-	-	-	-	INH	81		4
SBC #opr SBC opr SBC opr SBC opr,X SBC opr,X SBC ,X SBC opr,SP SBC opr,SP	Subtract with Carry	$A \leftarrow (A) - (M) - (C)$	↑	-	-	↑	↓	↓	IMM DIR EXT IX2 IX1 IX SP1 SP2	A2 B2 C2 D2 E2 F2 9E E2 9E D2	ii dd hh ll ee ff ff ff ff ee ff ff	2 3 4 4 3 2 4 5
SEC	Set Carry Bit	$C \leftarrow 1$	-	-	-	-	-	1	INH	99		1

Table 6-1. Instruction Set Summary (Continued)

Source Form	Operation	Description	Effect on CCR						Address Mode	Opcode	Operand	Cycles
			V	H	I	N	Z	C				
SEI	Set Interrupt Mask	$I \leftarrow 1$	-	-	1	-	-	-	INH	9B		2
STA <i>opr</i> STA <i>opr</i> STA <i>opr,X</i> STA <i>opr,X</i> STA <i>,X</i> STA <i>opr,SP</i> STA <i>opr,SP</i>	Store A in M	$M \leftarrow (A)$	0	-	-	↓	↓	-	DIR EXT IX2 IX1 IX SP1 SP2	B7 C7 D7 E7 F7 9E E7 9E D7	hh ll ee ff ff ff ff ff ff	3 4 4 3 2 4 5
STHX <i>opr</i>	Store H:X in M	$(M:M + 1) \leftarrow (H:X)$	0	-	-	↓	↓	-	DIR	35	dd	4
STOP	Enable \overline{IRQ} Pin; Stop Oscillator	$I \leftarrow 0$; Stop Oscillator	-	-	0	-	-	-	INH	8E		1
STX <i>opr</i> STX <i>opr</i> STX <i>opr,X</i> STX <i>opr,X</i> STX <i>,X</i> STX <i>opr,SP</i> STX <i>opr,SP</i>	Store X in M	$M \leftarrow (X)$	0	-	-	↓	↓	-	DIR EXT IX2 IX1 IX SP1 SP2	BF CF DF EF FF 9E EF 9E DF	hh ll ee ff ff ff ff ff ff	3 4 4 3 2 4 5
SUB # <i>opr</i> SUB <i>opr</i> SUB <i>opr</i> SUB <i>opr,X</i> SUB <i>opr,X</i> SUB <i>,X</i> SUB <i>opr,SP</i> SUB <i>opr,SP</i>	Subtract	$A \leftarrow (A) - (M)$	↓	-	-	↓	↓	↓	IMM DIR EXT IX2 IX1 IX SP1 SP2	A0 B0 C0 D0 E0 F0 9E E0 9E D0	ii dd hh ll ee ff ff ff ff ff	2 3 4 4 3 2 4 5
SWI	Software Interrupt	PC \leftarrow (PC) + 1; Push (PCL) SP \leftarrow (SP) - 1; Push (PCH) SP \leftarrow (SP) - 1; Push (X) SP \leftarrow (SP) - 1; Push (A) SP \leftarrow (SP) - 1; Push (CCR) SP \leftarrow (SP) - 1; I \leftarrow 1 PCH \leftarrow Interrupt Vector High Byte PCL \leftarrow Interrupt Vector Low Byte	-	-	1	-	-	-	INH	83		9
TAP	Transfer A to CCR	$CCR \leftarrow (A)$	↓	↓	↓	↓	↓	↓	INH	84		2
TAX	Transfer A to X	$X \leftarrow (A)$	-	-	-	-	-	-	INH	97		1
TPA	Transfer CCR to A	$A \leftarrow (CCR)$	-	-	-	-	-	-	INH	85		1
TST <i>opr</i> TSTA TSTX TST <i>opr,X</i> TST <i>,X</i> TST <i>opr,SP</i>	Test for Negative or Zero	$(A) - \$00$ or $(X) - \$00$ or $(M) - \$00$	0	-	-	↓	↓	-	DIR INH INH IX1 IX SP1	3D 4D 5D 6D 7D 9E 6D	dd ff ff	3 1 1 3 2 4
TSX	Transfer SP to H:X	$H:X \leftarrow (SP) + 1$	-	-	-	-	-	-	INH	95		2

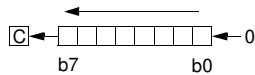
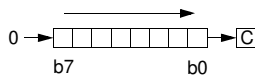
Table 6-1. Instruction Set Summary (Continued)

Source Form	Operation	Description	Effect on CCR						Address Mode	Opcode	Operand	Cycles
			V	H	I	N	Z	C				
TXA	Transfer X to A	$A \leftarrow (X)$	-	-	-	-	-	-	INH	9F		1
TXS	Transfer H:X to SP	$(SP) \leftarrow (H:X) - 1$	-	-	-	-	-	-	INH	94		2

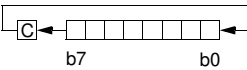
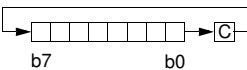
A Accumulator	Any bit
C Carry/borrow bit	Operand (one or two bytes)
CCR Condition code register	Program counter
dd Direct address of operand	Program counter high byte
dd r Direct address of operand and relative offset of branch instruction	Program counter low byte
DDD Direct to direct addressing mode	Relative addressing mode
DIR Direct addressing mode	Relative program counter offset byte
DIX+ Direct to indexed with post increment addressing mode	Relative program counter offset byte
ee ff High and low bytes of offset in indexed, 16-bit offset addressing	Stack pointer, 8-bit offset addressing mode
EXT Extended addressing mode	Stack pointer 16-bit offset addressing mode
ff Offset byte in indexed, 8-bit offset addressing	Stack pointer
H Half-carry bit	Undefined
H Index register high byte	Overflow bit
hh ll High and low bytes of operand address in extended addressing	Index register low byte
I Interrupt mask	Zero bit
ii Immediate operand byte	Logical AND
IMD Immediate source to direct destination addressing mode	Logical OR
IMM Immediate addressing mode	Logical EXCLUSIVE OR
INH Inherent addressing mode	Contents of
IX Indexed, no offset addressing mode	Negation (two's complement)
IX+ Indexed, no offset, post increment addressing mode	Immediate value
IX+D Indexed with post increment to direct addressing mode	Sign extend
IX1 Indexed, 8-bit offset addressing mode	Loaded with
IX1+ Indexed, 8-bit offset, post increment addressing mode	If
IX2 Indexed, 16-bit offset addressing mode	Concatenated with
MMemory location	Set or cleared
N Negative bit	Not affected

6.9 Opcode Map

The opcode map is provided in [Table 6-2](#).

Central Processor Unit (CPU)

Table 6-2. Opcode Map

Bit Manipulation			Branch				Read-Modify-Write				Control				Register/Memory				
DIR	DIR	REL	DIR	DIR	INH	INH	IX1	SP1	IX	INH	INH	IMM	DIR	EXT	IX2	SP2	IX1	SP1	IX
0	1	2	3	4	5	6	9E6	7	8	9	A	B	C	D	9ED	E	9EE	F	
BRSET0	BSET0	BRA	NEG	NEGX	NEG	NEG	NEG	RTI	BGE	3	SUB	SUB	SUB	SUB	SUB	SUB	SUB	SUB	SUB
3	DIR	2	DIR	1	INH	1	SP1	1	INH	2	IMM	2	EXT	3	IX2	4	IX1	3	IX
BRCLR0	BCLR0	BRN	CBEQ	CBEQX	CBEQ	CBEQ	SP1	2	INH	4	IMM	3	EXT	4	IX2	5	IX1	4	IX
3	DIR	2	DIR	3	IMM	3	IX1+	2	INH	2	IMM	2	EXT	3	IX2	4	IX1	3	IX
BRSET1	BSET1	BHI	MUL	DIV	NSA	NSA	INH	1	INH	7	SBC	SBC	SBC	SBC	SBC	SBC	SBC	SBC	SBC
3	DIR	2	REL	1	INH	1	INH	1	INH	2	IMM	2	EXT	3	IX2	4	IX1	3	IX
BRCLR1	BCLR1	BLS	COM	COMX	COM	COM	SP1	5	INH	9	CPX	CPX	CPX	CPX	CPX	CPX	CPX	CPX	CPX
3	DIR	2	DIR	1	INH	2	SP1	3	INH	2	IMM	2	EXT	3	IX2	4	IX1	3	IX
BRSET2	BSET2	BCC	LSR	LSRX	LSR	LSR	SP1	5	INH	2	AND	AND	AND	AND	AND	AND	AND	AND	AND
3	DIR	2	DIR	1	INH	2	SP1	3	INH	1	IMM	2	EXT	3	IX2	4	IX1	3	IX
BRCLR2	BCLR2	BCS	LDHX	LDHX	CPHX	CPHX	INH	4	INH	2	IMM	2	EXT	3	IX2	4	IX1	3	IX
3	DIR	2	REL	2	DIR	3	IMM	3	INH	1	IMM	2	EXT	3	IX2	4	IX1	3	IX
BRSET3	BSET3	BNE	ROR	RORX	ROR	ROR	SP1	5	INH	2	LDA	LDA	LDA	LDA	LDA	LDA	LDA	LDA	LDA
3	DIR	2	DIR	1	INH	4	SP1	3	INH	2	IMM	2	EXT	3	IX2	4	IX1	3	IX
BRCLR3	BCLR3	BEQ	ASR	ASRX	ASR	ASR	SP1	5	INH	2	IMM	2	EXT	3	IX2	4	IX1	3	IX
3	DIR	2	DIR	1	INH	4	SP1	3	INH	1	IMM	2	EXT	3	IX2	4	IX1	3	IX
BRSET4	BSET4	BHCC	LSL	LSLX	LSL	LSL	SP1	5	INH	2	IMM	2	EXT	3	IX2	4	IX1	3	IX
3	DIR	2	REL	1	INH	4	SP1	3	INH	1	IMM	2	EXT	3	IX2	4	IX1	3	IX
BRCLR4	BCLR4	BHCS	ROL	ROLX	ROL	ROL	SP1	5	INH	2	IMM	2	EXT	3	IX2	4	IX1	3	IX
3	DIR	2	REL	1	INH	4	SP1	3	INH	1	IMM	2	EXT	3	IX2	4	IX1	3	IX
BRSET5	BSET5	BPL	DEC	DECX	DEC	DEC	SP1	5	INH	2	IMM	2	EXT	3	IX2	4	IX1	3	IX
3	DIR	2	DIR	1	INH	4	SP1	3	INH	1	IMM	2	EXT	3	IX2	4	IX1	3	IX
BRCLR5	BCLR5	BMI	DBNZ	DBNZX	DBNZ	DBNZ	SP1	5	INH	2	IMM	2	EXT	3	IX2	4	IX1	3	IX
3	DIR	2	DIR	2	INH	3	SP1	4	INH	1	IMM	2	EXT	3	IX2	4	IX1	3	IX
BRSET6	BSET6	BMC	INC	INCX	INC	INC	SP1	5	INH	2	IMM	2	EXT	3	IX2	4	IX1	3	IX
3	DIR	2	REL	1	INH	4	SP1	3	INH	1	IMM	2	EXT	3	IX2	4	IX1	3	IX
BRCLR6	BCLR6	BMS	TST	TSTX	TST	TST	SP1	5	INH	2	IMM	2	EXT	3	IX2	4	IX1	3	IX
3	DIR	2	REL	1	INH	4	SP1	3	INH	1	IMM	2	EXT	3	IX2	4	IX1	3	IX
BRSET7	BSET7	BIL	MOV	MOVX	MOV	MOV	SP1	5	INH	2	IMM	2	EXT	3	IX2	4	IX1	3	IX
3	DIR	2	REL	2	DIR	3	IMD	4	INH	1	IMM	2	EXT	3	IX2	4	IX1	3	IX
BRCLR7	BCLR7	BIH	CLR	CLRX	CLR	CLR	SP1	5	INH	2	IMM	2	EXT	3	IX2	4	IX1	3	IX
3	DIR	2	REL	1	INH	4	SP1	3	INH	1	IMM	2	EXT	3	IX2	4	IX1	3	IX

MSB
LSB
0 1 2 3 4 5 6 7 8 9 A B C D E F

INH Inherent
IMM Immediate
DIR Direct
EXT Extended
DD Direct-Direct
IX+D Indexed-Direct
* Pre-byte for stack pointer indexed instructions

REL Relative
IX Indexed, No Offset
IX1 Indexed, 8-Bit Offset
IX2 Indexed, 16-Bit Offset
IMD Immediate-Direct
DIX+ Direct-Indexed

SP1 Stack Pointer, 8-Bit Offset
SP2 Stack Pointer, 16-Bit Offset
IX+ Indexed, No Offset with Post Increment
IX1+ Indexed, 1-Byte Offset with Post Increment

MSB	0
LSB	5

High Byte of Opcode in Hexadecimal
Cycles
Opcode Mnemonic
Number of Bytes / Addressing Mode

Low Byte of Opcode in Hexadecimal
BRSET0
DIR

Section 7. System Integration Module (SIM)

7.1 Contents

7.2	Introduction	102
7.3	SIM Bus Clock Control and Generation	104
7.3.1	Bus Timing	104
7.3.2	Clock Startup from POR or LVI Reset	105
7.3.3	Clocks in Stop Mode and Wait Mode	105
7.4	Reset and System Initialization	106
7.4.1	External Pin Reset	106
7.4.2	Active Resets from Internal Sources	107
7.4.2.1	Power-On Reset	108
7.4.2.2	Computer Operating Properly (COP) Reset	109
7.4.2.3	Illegal Opcode Reset	109
7.4.2.4	Illegal Address Reset	109
7.4.2.5	Low-Voltage Inhibit (LVI) Reset	110
7.5	SIM Counter	110
7.5.1	SIM Counter During Power-On Reset	110
7.5.2	SIM Counter During Stop Mode Recovery	111
7.5.3	SIM Counter and Reset States	111
7.6	Program Exception Control	111
7.6.1	Interrupts	112
7.6.2	Reset	115
7.6.3	Break Interrupts	116
7.6.4	Status Flag Protection in Break Mode	116
7.7	Low-Power Modes	116
7.7.1	Wait Mode	117
7.7.2	Stop Mode	118
7.8	SIM Registers	119
7.8.1	SIM Break Status Register	120

7.8.2	SIM Reset Status Register	121
7.8.3	SIM Break Flag Control Register	122

7.2 Introduction

This section describes the system integration module (SIM), which supports up to 32 external and/or internal interrupts. Together with the central processor unit (CPU), the SIM controls all MCU activities. A block diagram of the SIM is shown in **Figure 7-1**. **Figure 7-2** is a summary of the SIM input/output (I/O) registers. The SIM is a system state controller that coordinates CPU and exception timing. The SIM is responsible for:

- Bus clock generation and control for CPU and peripherals
 - Stop/wait/reset/break entry and recovery
 - Internal clock control
- Master reset control, including power-on reset (POR) and computer operating properly (COP) timeout
- Interrupt control:
 - Acknowledge timing
 - Arbitration control timing
 - Vector address generation
- CPU enable/disable timing

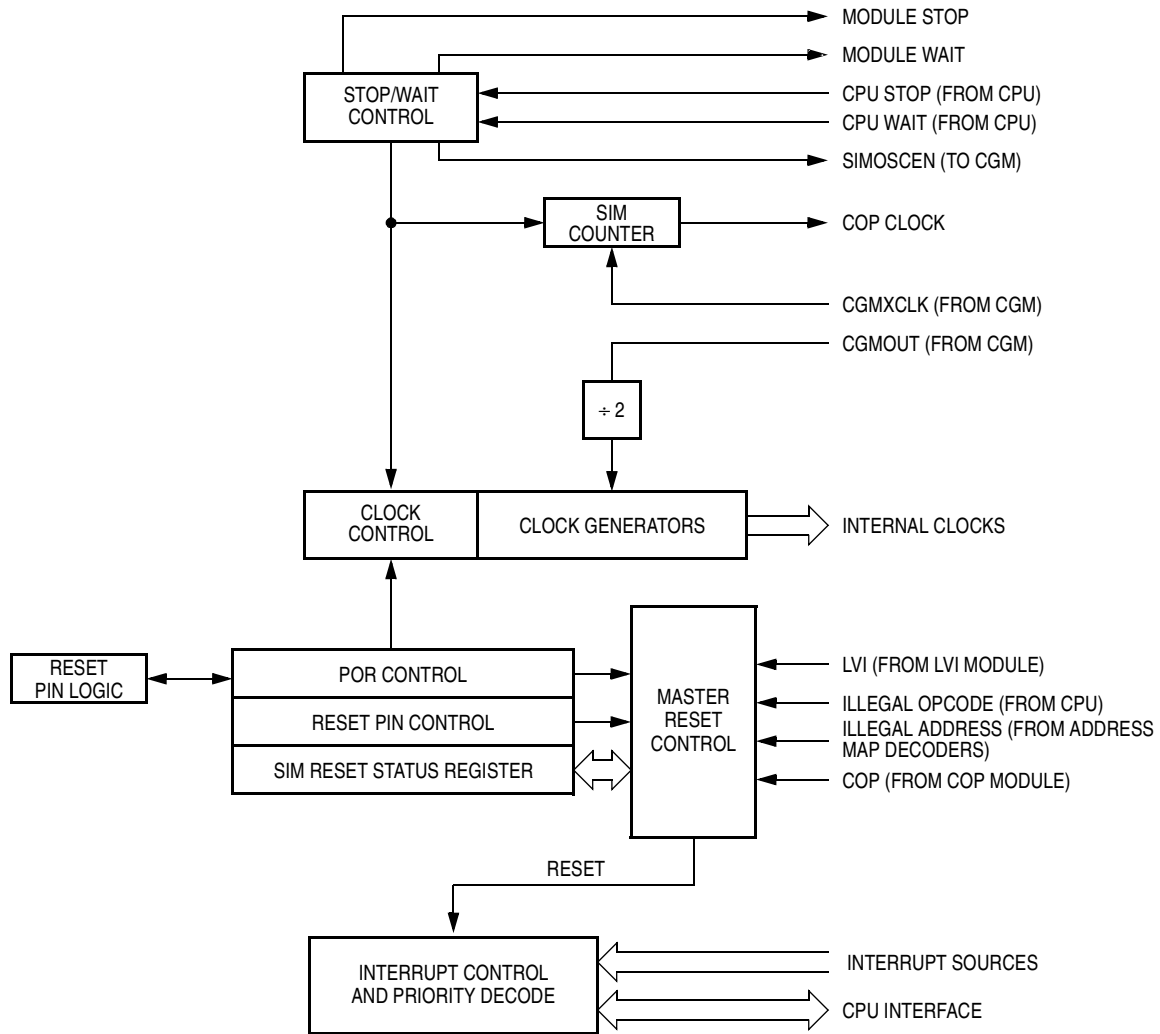

Figure 7-1. SIM Block Diagram

Register Name	Bit 7	6	5	4	3	2	1	Bit 0
SIM Break Status Register (SBSR)	R	R	R	R	R	R	BW	R
SIM Reset Status Register (SRSR)	POR	PIN	COP	ILOP	ILAD	0	LVI	0
SIM Break Flag Control Register (SBFCR)	BCFE	R	R	R	R	R	R	R

R = Reserved

Figure 7-2. SIM I/O Register Summary

Table 7-1. I/O Register Address Summary

Register	SBSR	SRSR	SBFCR
Address	\$FE00	\$FE01	\$FE03

Table 7-2 shows the internal signal names used in this section.

Table 7-2. Signal Name Conventions

Signal Name	Description
CGMXCLK	Buffered Version of OSC1 from Clock Generator Module (CGM)
CGMVCLK	PLL Output
CGMOUT	PLL-Based or OSC1-Based Clock Output from CGM Module (Bus Clock = CGMOUT Divided by Two)
IAB	Internal Address Bus
IDB	Internal Data Bus
PORRST	Signal from the Power-On Reset Module to the SIM
IRST	Internal Reset Signal
R/W	Read/Write Signal

7.3 SIM Bus Clock Control and Generation

The bus clock generator provides system clock signals for the CPU and peripherals on the MCU. The system clocks are generated from an incoming clock, CGMOUT, as shown in [Figure 7-3](#). This clock can come from either an external oscillator or from the on-chip PLL. (See [Clock Generator Module \(CGM\)](#) on page 123).

7.3.1 Bus Timing

In user mode, the internal bus frequency is either the crystal oscillator output (CGMXCLK) divided by four or the PLL output (CGMVCLK) divided by four. (See [Clock Generator Module \(CGM\)](#) on page 123).

7.3.2 Clock Startup from POR or LVI Reset

When the power-on reset module or the low-voltage inhibit module generates a reset, the clocks to the CPU and peripherals are inactive and held in an inactive phase until after 4096 CGMXCLK cycles. The $\overline{\text{RST}}$ pin is driven low by the SIM during this entire period. The bus clocks start upon completion of the timeout.

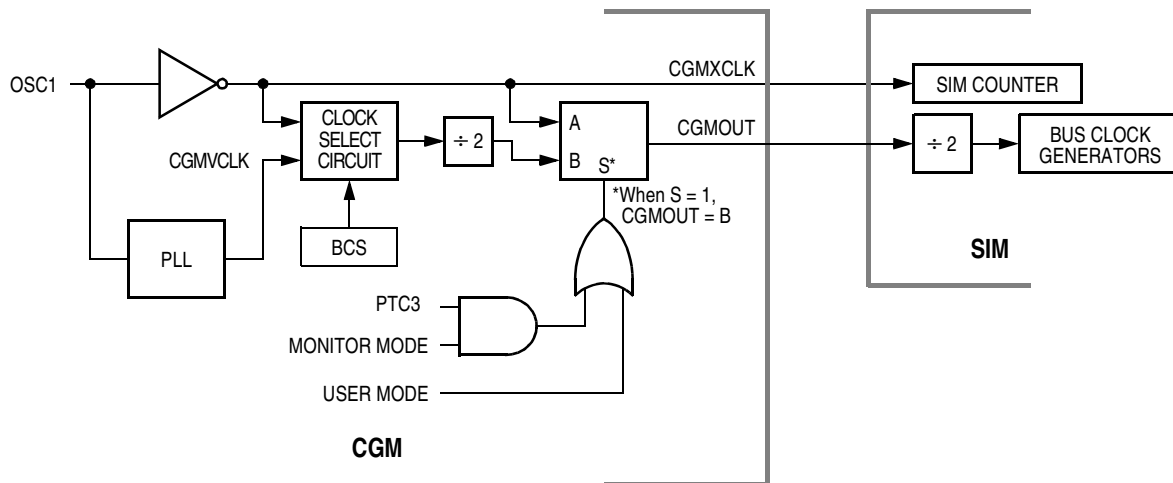

Figure 7-3. CGM Clock Signals

7.3.3 Clocks in Stop Mode and Wait Mode

Upon exit from stop mode by an interrupt, break, or reset, the SIM allows CGMXCLK to clock the SIM counter. The CPU and peripheral clocks do not become active until after the stop delay timeout. This timeout is selectable as 4096 or 32 CGMXCLK cycles. See [Stop Mode](#) on page 118.

In wait mode, the CPU clocks are inactive. Refer to the wait mode subsection of each module to see if the module is active or inactive in wait mode. Some modules can be programmed to be active in wait mode.

7.4 Reset and System Initialization

The MCU has these reset sources:

- Power-on reset module (POR)
- External reset pin ($\overline{\text{RST}}$)
- Computer operating properly module (COP)
- Low-voltage inhibit module (LVI)
- Illegal opcode
- Illegal address

All of these resets produce the vector \$FFFE–FFFF (\$FEFE–FEFF in monitor mode) and assert the internal reset signal (IRST). IRST causes all registers to be returned to their default values and all modules to be returned to their reset states.

An internal reset clears the SIM counter (see [SIM Counter](#) on page 110), but an external reset does not. Each of the resets sets a corresponding bit in the SIM reset status register (SRSR) (see [SIM Registers](#) on page 119).

7.4.1 External Pin Reset

Pulling the asynchronous $\overline{\text{RST}}$ pin low halts all processing. The PIN bit of the SIM reset status register (SRSR) is set as long as $\overline{\text{RST}}$ is held low for a minimum of 67 CGMXCLK cycles, assuming that neither the POR nor the LVI was the source of the reset. See [Table 7-3](#) for details. [Figure 7-4](#) shows the relative timing.

Table 7-3. PIN Bit Set Timing

Reset Type	Number of Cycles Required to Set PIN
POR/LVI	4163 (4096 + 64 + 3)
All others	67 (64 + 3)

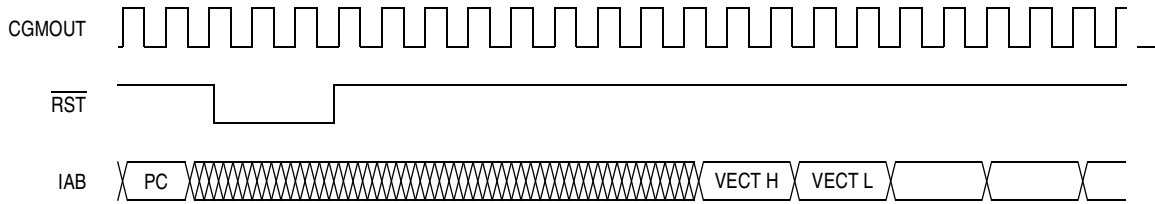

Figure 7-4. External Reset Timing

7.4.2 Active Resets from Internal Sources

All internal reset sources actively pull the $\overline{\text{RST}}$ pin low for 32 CGMXCLK cycles to allow resetting of external peripherals. The internal reset signal IRST continues to be asserted for an additional 32 cycles (see [Figure 7-5](#)). An internal reset can be caused by an illegal address, illegal opcode, COP timeout, LVI, or POR (see [Figure 7-6](#)). Note that for LVI or POR resets, the SIM cycles through 4096 CGMXCLK cycles during which the SIM forces the $\overline{\text{RST}}$ pin low. The internal reset signal then follows the sequence from the falling edge of $\overline{\text{RST}}$ shown in [Figure 7-5](#).

The COP reset is asynchronous to the bus clock.

The active reset feature allows the part to issue a reset to peripherals and other chips within a system built around the MCU.

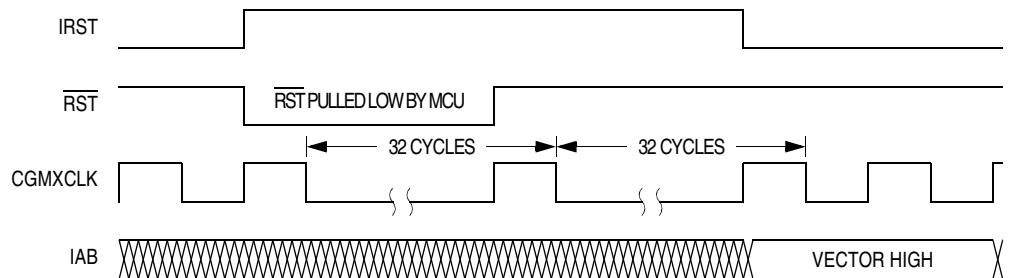

Figure 7-5. Internal Reset Timing

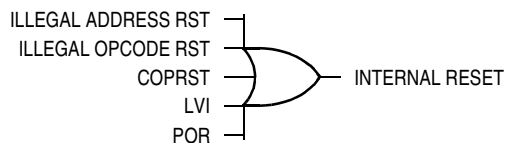

Figure 7-6. Sources of Internal Reset

7.4.2.1 Power-On Reset

When power is first applied to the MCU, the power-on reset module (POR) generates a pulse to indicate that power-on has occurred. The external reset pin (\overline{RST}) is held low while the SIM counter counts out 4096 CGMXCLK cycles. Another sixty-four CGMXCLK cycles later, the CPU and memories are released from reset to allow the reset vector sequence to occur.

At power-on, the following events occur:

- A POR pulse is generated.
- The internal reset signal is asserted.
- The SIM enables CGMOUT.
- Internal clocks to the CPU and modules are held inactive for 4096 CGMXCLK cycles to allow stabilization of the oscillator.
- The \overline{RST} pin is driven low during the oscillator stabilization time.
- The POR bit of the SIM reset status register (SRSR) is set and all other bits in the register are cleared.

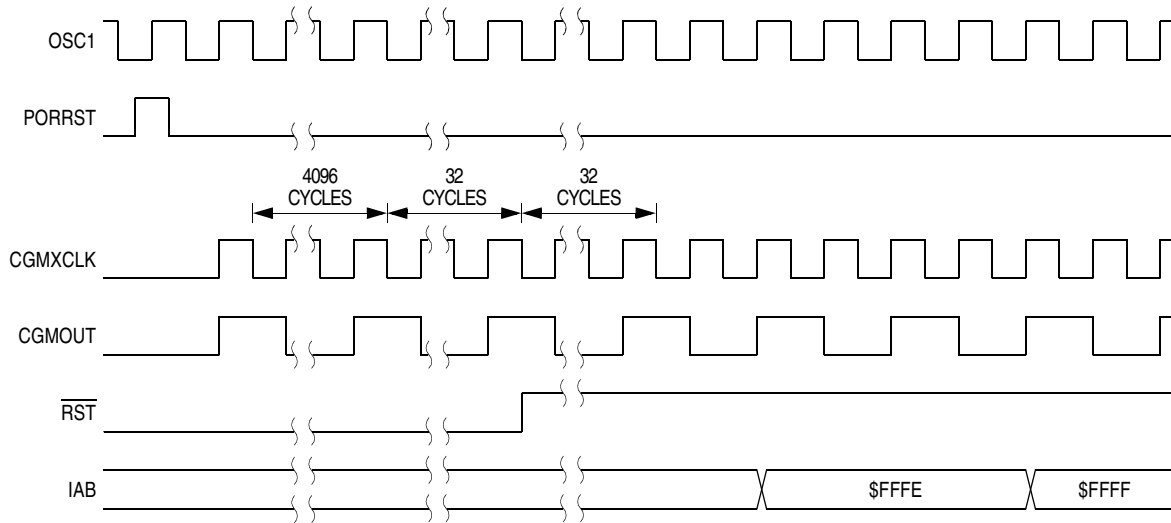

Figure 7-7. POR Recovery

7.4.2.2 Computer Operating Properly (COP) Reset

The overflow of the COP counter causes an internal reset and sets the COP bit in the SIM reset status register (SRSR) if the COPD bit in the CONFIG-1 register is at logic zero.

See [Computer Operating Properly \(COP\)](#) on page 175.

7.4.2.3 Illegal Opcode Reset

The SIM decodes signals from the CPU to detect illegal instructions. An illegal instruction sets the ILOP bit in the SIM reset status register (SRSR) and causes a reset.

If the stop enable bit, STOP, in the CONFIG-1 register is logic zero, the SIM treats the STOP instruction as an illegal opcode and causes an illegal opcode reset.

7.4.2.4 Illegal Address Reset

An opcode fetch from an unmapped address generates an illegal address reset. The SIM verifies that the CPU is fetching an opcode prior to asserting the ILAD bit in the SIM reset status register SRSR) and

resetting the MCU. A data fetch from an unmapped address does not generate a reset. The SIM actively pulls down the $\overline{\text{RST}}$ pin for all internal reset sources.

NOTE: *Extra care should be exercised if code in this part has been migrated from older HC08 devices since the illegal address reset specification may be different. Also, extra care should be exercised when using this emulation part for development of code to be run in ROM AZ, AB or AS family parts with a smaller memory size since some legal addresses will become illegal addresses on the smaller ROM memory map device and may as a result generate unwanted resets.*

7.4.2.5 Low-Voltage Inhibit (LVI) Reset

The low-voltage inhibit module (LVI) asserts its output to the SIM when the V_{DD} voltage falls to the V_{LVII} voltage. The LVI bit in the SIM reset status register (SRSR) is set and a chip reset is asserted if the LVIPWRD and LVIRSTD bits in the CONFIG-1 register are at logic zero. The $\overline{\text{RST}}$ pin will be held low until the SIM counts 4096 CGMXCLK cycles after V_{DD} rises above V_{LVIR} . Another sixty-four CGMXCLK cycles later, the CPU is released from reset to allow the reset vector sequence to occur. See [Low Voltage Inhibit \(LVI\)](#) on page 181.

7.5 SIM Counter

The SIM counter is used by the power-on reset module (POR) and in stop mode recovery to allow the oscillator time to stabilize before enabling the internal bus (IBUS) clocks. The SIM counter also serves as a prescaler for the computer operating properly module (COP). The SIM counter overflow supplies the clock for the COP module. The SIM counter is 12 bits long and is clocked by the falling edge of CGMXCLK.

7.5.1 SIM Counter During Power-On Reset

The power-on reset module (POR) detects power applied to the MCU. At power-on, the POR circuit asserts the signal PORRST. Once the SIM

is initialized, it enables the clock generation module (CGM) to drive the bus clock state machine.

7.5.2 SIM Counter During Stop Mode Recovery

The SIM counter also is used for stop mode recovery. The STOP instruction clears the SIM counter. After an interrupt or reset, the SIM senses the state of the short stop recovery bit, SSREC, in the CONFIG-1 register. If the SSREC bit is a logic one, then the stop recovery is reduced from the normal delay of 4096 CGMXCLK cycles down to 32 CGMXCLK cycles. This is ideal for applications using canned oscillators that do not require long start-up times from stop mode. External crystal applications should use the full stop recovery time, that is, with SSREC cleared.

7.5.3 SIM Counter and Reset States

External reset has no effect on the SIM counter. See [Stop Mode](#) on page 118 for details. The SIM counter is free-running after all reset states. See [Active Resets from Internal Sources](#) on page 107 for counter control and internal reset recovery sequences.

7.6 Program Exception Control

Normal, sequential program execution can be changed in three different ways:

- Interrupts
 - Maskable hardware CPU interrupts
 - Non-maskable software interrupt instruction (SWI)
- Reset
- Break interrupts

7.6.1 Interrupts

At the beginning of an interrupt, the CPU saves the CPU register contents on the stack and sets the interrupt mask (I bit) to prevent additional interrupts. At the end of an interrupt, the RTI instruction recovers the CPU register contents from the stack so that normal processing can resume. [Figure 7-8](#) shows interrupt entry timing. [Figure 7-10](#) shows interrupt recovery timing.

Interrupts are latched, and arbitration is performed in the SIM at the start of interrupt processing. The arbitration result is a constant that the CPU uses to determine which vector to fetch. Once an interrupt is latched by the SIM, no other interrupt can take precedence, regardless of priority, until the latched interrupt is serviced (or the I bit is cleared), see [Figure 7-9](#).

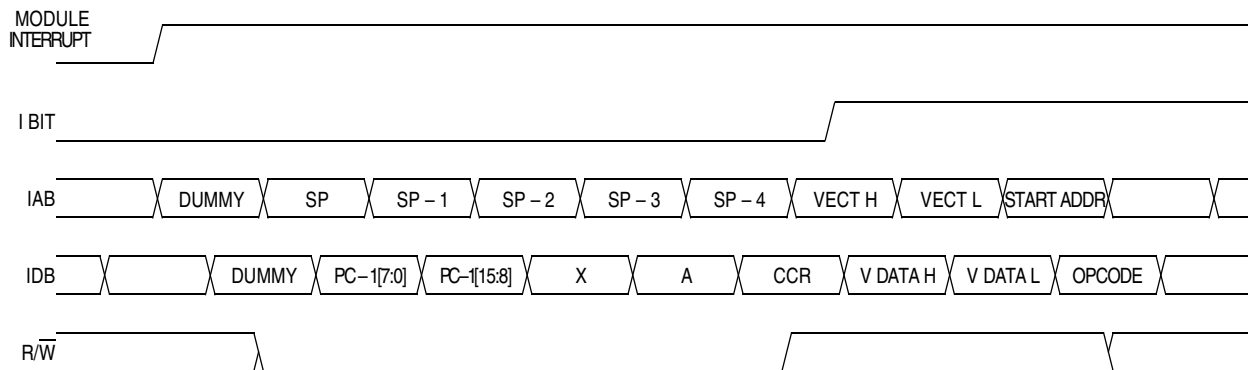

Figure 7-8. Interrupt Entry

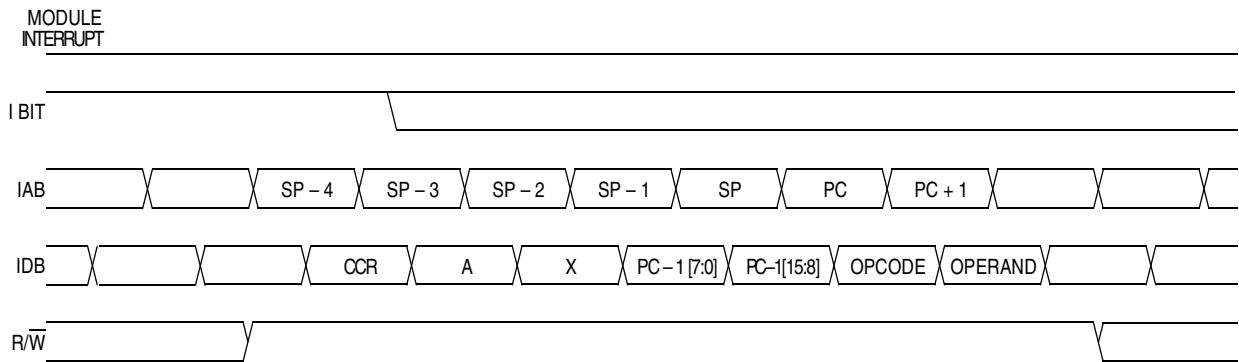

Figure 7-10. Interrupt Recovery

Hardware Interrupts

A hardware interrupt does not stop the current instruction. Processing of a hardware interrupt begins after completion of the current instruction. When the current instruction is complete, the SIM checks all pending hardware interrupts. If interrupts are not masked (I bit clear in the condition code register), and if the corresponding interrupt enable bit is set, the SIM proceeds with interrupt processing; otherwise, the next instruction is fetched and executed.

If more than one interrupt is pending at the end of an instruction execution, the highest priority interrupt is serviced first. [Figure 7-11](#) demonstrates what happens when two interrupts are pending. If an interrupt is pending upon exit from the original interrupt service routine, the pending interrupt is serviced before the LDA instruction is executed.

The LDA opcode is prefetched by both the INT1 and INT2 RTI instructions. However, in the case of the INT1 RTI prefetch, this is a redundant operation.

NOTE: *To maintain compatibility with the M68HC05, M6805 and M146805 Families the H register is not pushed on the stack during interrupt entry. If the interrupt service routine modifies the H register or uses the indexed addressing mode, software should save the H register and then restore it prior to exiting the routine.*

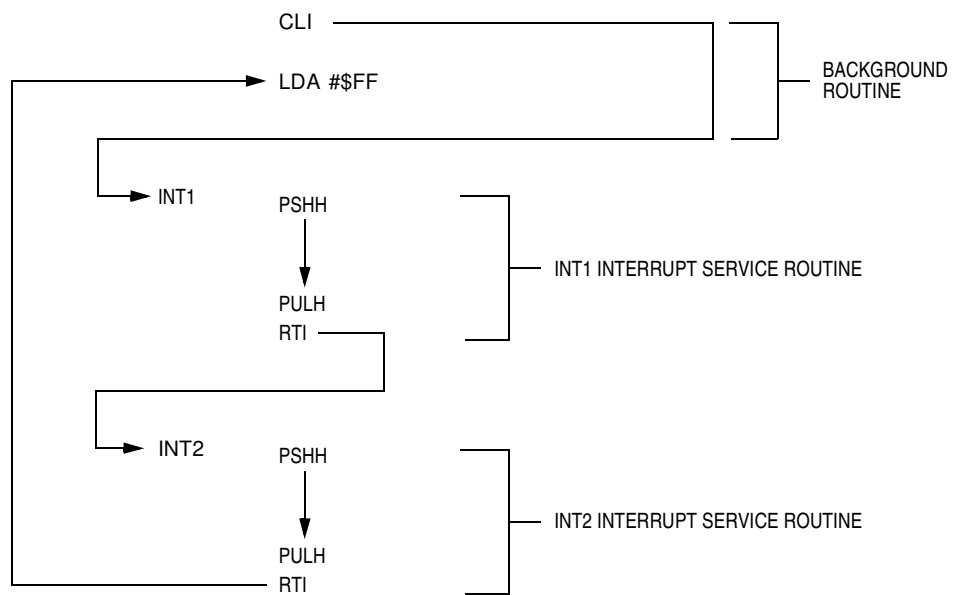

Figure 7-11. Interrupt Recognition Example

SWI Instruction

The SWI instruction is a non-maskable instruction that causes an interrupt regardless of the state of the interrupt mask (I bit) in the condition code register.

NOTE: *A software interrupt pushes PC onto the stack. A software interrupt does **not** push PC – 1, as a hardware interrupt does.*

7.6.2 Reset

All reset sources always have higher priority than interrupts and cannot be arbitrated.

7.6.3 Break Interrupts

The break module can stop normal program flow at a software-programmable break point by asserting its break interrupt output. See [Break Module \(BRK\)](#) on page 157. The SIM puts the CPU into the break state by forcing it to the SWI vector location. Refer to the break interrupt subsection of each module to see how each module is affected by the break state.

7.6.4 Status Flag Protection in Break Mode

The SIM controls whether status flags contained in other modules can be cleared during break mode. The user can select whether flags are protected from being cleared by properly initializing the break clear flag enable bit (BCFE) in the SIM break flag control register (SBFCR).

Protecting flags in break mode ensures that set flags will not be cleared while in break mode. This protection allows registers to be freely read and written during break mode without losing status flag information.

Setting the BCFE bit enables the clearing mechanisms. Once cleared in break mode, a flag remains cleared even when break mode is exited. Status flags with a two-step clearing mechanism — for example, a read of one register followed by the read or write of another — are protected, even when the first step is accomplished prior to entering break mode. Upon leaving break mode, execution of the second step will clear the flag as normal.

7.7 Low-Power Modes

Executing the WAIT or STOP instruction puts the MCU in a low power-consumption mode for standby situations. The SIM holds the CPU in a non-clocked state. The operation of each of these modes is described below. Both STOP and WAIT clear the interrupt mask (I) in the condition code register, allowing interrupts to occur.

7.7.1 Wait Mode

In wait mode, the CPU clocks are inactive while one set of peripheral clocks continue to run. **Figure 7-12** shows the timing for wait mode entry.

A module that is active during wait mode can wake up the CPU with an interrupt if the interrupt is enabled. Stacking for the interrupt begins one cycle after the WAIT instruction during which the interrupt occurred. Refer to the wait mode subsection of each module to see if the module is active or inactive in wait mode. Some modules can be programmed to be active in wait mode.

Wait mode can also be exited by a reset or break. A break interrupt during wait mode sets the SIM break wait bit, BW, in the SIM break status register (SBSR). If the COP disable bit, COPD, in the configuration register is logic 0, then the computer operating properly module (COP) is enabled and remains active in wait mode.

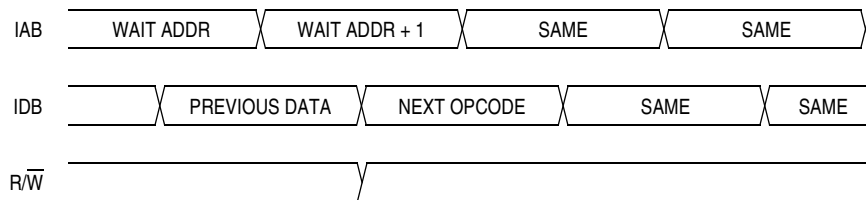

NOTE: Previous data can be operand data or the WAIT opcode, depending on the last instruction.

Figure 7-12. Wait Mode Entry Timing

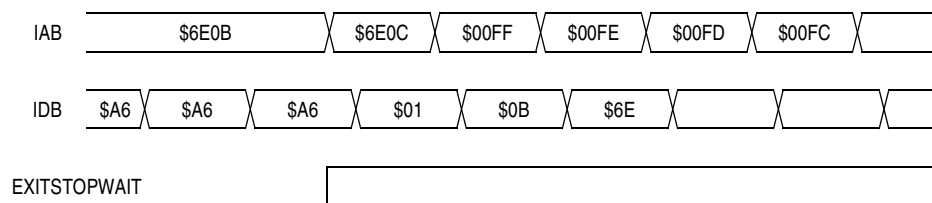

NOTE: EXITSTOPWAIT = $\overline{\text{RST}}$ pin OR CPU interrupt OR break interrupt

Figure 7-13. Wait Recovery from Interrupt or Break

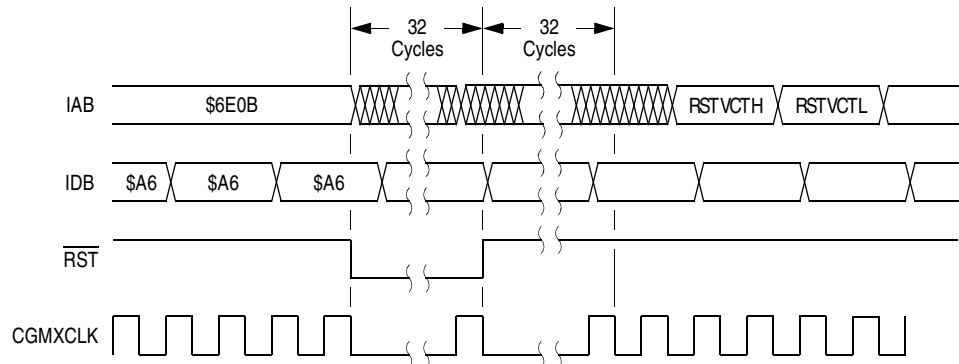

Figure 7-14. Wait Recovery from Internal Reset

7.7.2 Stop Mode

In stop mode, the SIM counter is reset and the system clocks are disabled. An interrupt request from a module can cause an exit from stop mode. Stacking for interrupts begins after the selected stop recovery time has elapsed. Reset also causes an exit from stop mode.

The SIM disables the clock generator module outputs (CGMOUT and CGMXCLK) in stop mode, stopping the CPU and peripherals. Stop recovery time is selectable using the SSREC bit in the configuration register (CONFIG-1). If SSREC is set, stop recovery is reduced from the normal delay of 4096 CGMXCLK cycles down to 32. This is ideal for applications using canned oscillators that do not require long startup times from stop mode.

NOTE: *External crystal applications should use the full stop recovery time by clearing the SSREC bit.*

The break module is inactive in Stop mode. The STOP instruction does not affect break module register states.

The SIM counter is held in reset from the execution of the STOP instruction until the beginning of stop recovery. It is then used to time the recovery period. [Figure 7-15](#) shows stop mode entry timing.

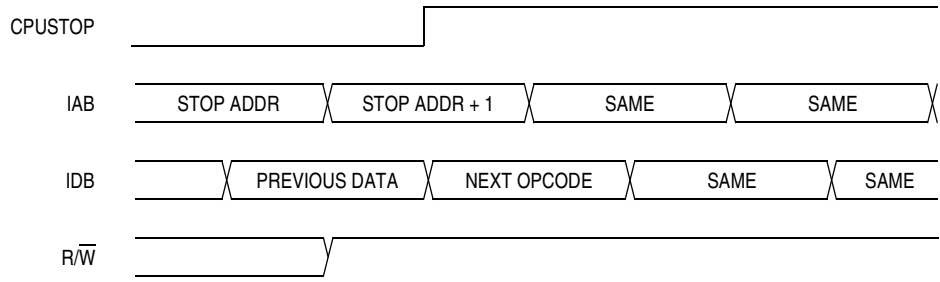

NOTE: Previous data can be operand data or the STOP opcode, depending on the last instruction.

Figure 7-15. Stop Mode Entry Timing

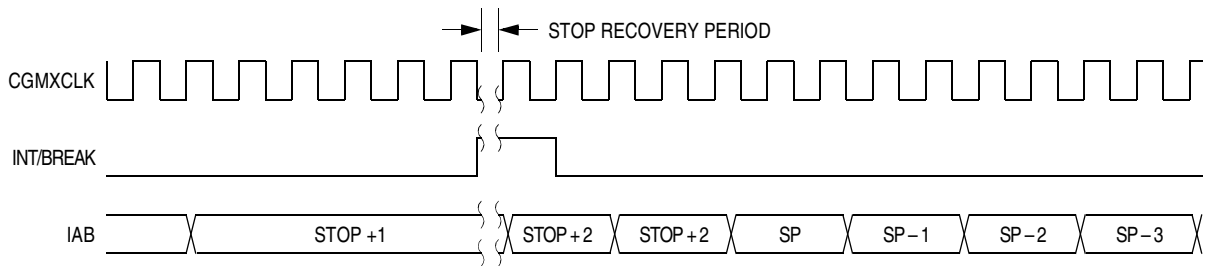

Figure 7-16. Stop Mode Recovery from Interrupt or Break

7.8 SIM Registers

The SIM has three memory mapped registers.

7.8.1 SIM Break Status Register

The SIM break status register contains a flag to indicate that a break caused an exit from wait mode.

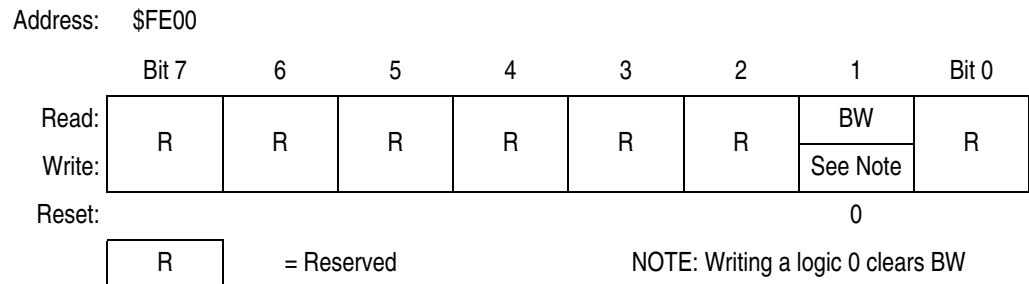

Figure 7-17. SIM Break Status Register (SBSR)

BW — SIM Break Wait

This status bit is useful in applications requiring a return to wait mode after exiting from a break interrupt. Clear BW by writing a logic 0 to it. Reset clears BW.

1 = Wait mode was exited by break interrupt

0 = Wait mode was not exited by break interrupt

BW can be read within the break state SWI routine. The user can modify the return address on the stack by subtracting one from it. The following code is an example of this. Writing zero to the BW bit clears it.

```

; This code works if the H register has been pushed onto the stack in the break
; service routine software. This code should be executed at the end of the
; break service routine software.
HIBYTE EQU 5
LOBYTE EQU 6
; If not BW, do RTI
BRCLR BW,SBSR, RETURN ; See if wait mode was exited by break.
;
TST LOBYTE,SP ; If RETURNLO is not zero,
BNE DOLO ; then just decrement low byte.
DEC HIBYTE,SP ; Else deal with high byte, too.
DOLO DEC LOBYTE,SP ; Point to WAIT/STOP opcode.
RETURN PULH ; Restore H register.
RTI

```

7.8.2 SIM Reset Status Register

This register contains six flags that show the source of the last reset. The status register will automatically clear after reading it. A power-on reset sets the POR bit and clears all other bits in the register.

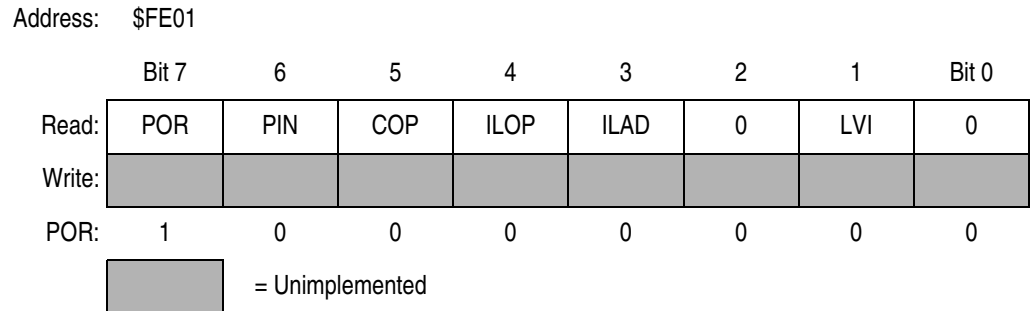

Figure 7-18. SIM Reset Status Register (SRSR)

POR — Power-On Reset Bit

- 1 = Last reset caused by POR circuit
- 0 = Read of SRSR

PIN — External Reset Bit

- 1 = Last reset caused by external reset pin (\overline{RST})
- 0 = POR or read of SRSR

COP — Computer Operating Properly Reset Bit

- 1 = Last reset caused by COP counter
- 0 = POR or read of SRSR

ILOP — Illegal Opcode Reset Bit

- 1 = Last reset caused by an illegal opcode
- 0 = POR or read of SRSR

ILAD — Illegal Address Reset Bit (opcode fetches only)

- 1 = Last reset caused by an opcode fetch from an illegal address
- 0 = POR or read of SRSR

LVI — Low-Voltage Inhibit Reset Bit

- 1 = Last reset was caused by the LVI circuit
- 0 = POR or read of SRSR

7.8.3 SIM Break Flag Control Register

The SIM break control register contains a bit that enables software to clear status bits while the MCU is in a break state.

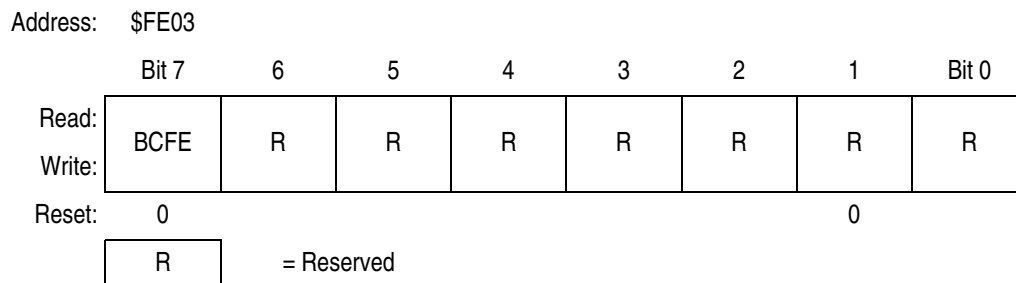

Figure 7-19. SIM Break Flag Control Register (SBFCR)

BCFE — Break Clear Flag Enable Bit

This read/write bit enables software to clear status bits by accessing status registers while the MCU is in a break state. To clear status bits during the break state, the BCFE bit must be set.

1 = Status bits clearable during break

0 = Status bits not clearable during break

Section 8. Clock Generator Module (CGM)

8.1 Contents

8.2	Introduction	124
8.3	Features	124
8.4	Functional Description	125
8.4.1	Crystal Oscillator Circuit	125
8.4.2	Phase-Locked Loop Circuit (PLL)	127
8.4.2.1	Circuits	127
8.4.2.2	Acquisition and Tracking Modes	129
8.4.2.3	Manual and Automatic PLL Bandwidth Modes	129
8.4.2.4	Programming the PLL	131
8.4.2.5	Special Programming Exceptions	133
8.4.3	Base Clock Selector Circuit	133
8.4.4	CGM External Connections	134
8.5	I/O Signals	135
8.5.1	Crystal Amplifier Input Pin (OSC1)	135
8.5.2	Crystal Amplifier Output Pin (OSC2)	135
8.5.3	External Filter Capacitor Pin (CGMXFC)	135
8.5.4	Analog Power Pin (V_{DDA})	136
8.5.5	Oscillator Enable Signal (SIMOSCEN)	136
8.5.6	Crystal Output Frequency Signal (CGMXCLK)	136
8.5.7	CGM Base Clock Output (CGMOUT)	136
8.5.8	CGM CPU Interrupt (CGMINT)	136
8.6	CGM Registers	137
8.6.1	PLL Control Register	137
8.6.2	PLL Bandwidth Control Register	139
8.6.3	PLL Programming Register	141
8.7	Interrupts	143
8.8	Low-Power Modes	143

8.8.1	Wait Mode	143
8.8.2	Stop Mode	144
8.9	CGM During Break Interrupts	144
8.10	Acquisition/Lock Time Specifications	144
8.10.1	Acquisition/Lock Time Definitions	144
8.10.2	Parametric Influences on Reaction Time	146
8.10.3	Choosing a Filter Capacitor	147
8.10.4	Reaction Time Calculation	147

8.2 Introduction

The CGM generates the crystal clock signal, CGMXCLK, which operates at the frequency of the crystal. The CGM also generates the base clock signal, CGMOUT, from which the system clocks are derived. CGMOUT is based on either the crystal clock divided by two or the phase-locked loop (PLL) clock, CGMVCLK, divided by two. The PLL is a frequency generator designed for use with 1-MHz to 8-MHz crystals or ceramic resonators. The PLL can generate an 8-MHz bus frequency without using high frequency crystals.

8.3 Features

Features of the CGM include:

- Phase-Locked Loop with Output Frequency in Integer Multiples of the Crystal Reference
- Programmable Hardware Voltage-Controlled Oscillator (VCO) for Low-Jitter Operation
- Automatic Bandwidth Control Mode for Low-Jitter Operation
- Automatic Frequency Lock Detector
- CPU Interrupt on Entry or Exit from Locked Condition

8.4 Functional Description

The CGM consists of three major submodules:

- Crystal oscillator circuit — The crystal oscillator circuit generates the constant crystal frequency clock, CGMXCLK.
- Phase-locked loop (PLL) — The PLL generates the programmable VCO frequency clock CGMVCLK.
- Base clock selector circuit — This software-controlled circuit selects either CGMXCLK divided by two or the VCO clock, CGMVCLK, divided by two as the base clock, CGMOUT. The system clocks are derived from CGMOUT.

Figure 8-1 shows the structure of the CGM.

8.4.1 Crystal Oscillator Circuit

The crystal oscillator circuit consists of an inverting amplifier and an external crystal. The OSC1 pin is the input to the amplifier and the OSC2 pin is the output. The SIMOSCEN signal enables the crystal oscillator circuit.

The CGMXCLK signal is the output of the crystal oscillator circuit and runs at a rate equal to the crystal frequency. CGMXCLK is then buffered to produce CGMRCLK, the PLL reference clock.

CGMXCLK can be used by other modules which require precise timing for operation. The duty cycle of CGMXCLK is not guaranteed to be 50% and depends on external factors, including the crystal and related external components.

An externally generated clock also can feed the OSC1 pin of the crystal oscillator circuit. Connect the external clock to the OSC1 pin and let the OSC2 pin float.

Clock Generator Module (CGM)

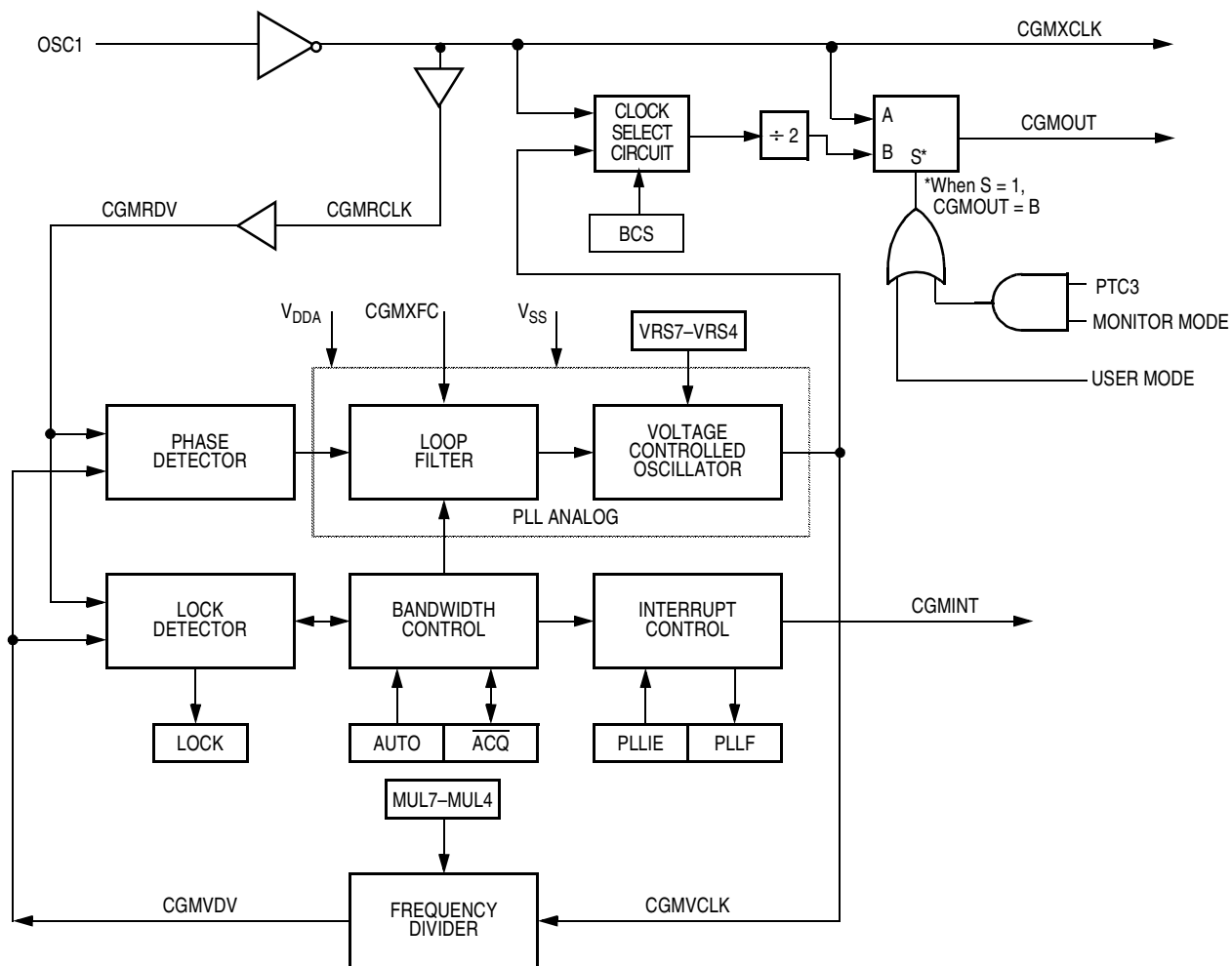

Figure 8-1. CGM Block Diagram

Register Name	Bit 7	6	5	4	3	2	1	Bit 0
PLL Control Register (PCTL)	Read:	PLLIE	PLLF	PLLON	BCS	1	1	1
	Write:							
	Reset:	0	0	1	0	1	1	1
PLL Bandwidth Control Register (PBWC)	Read:	AUTO	LOCK	$\overline{\text{ACQ}}$	XLD	0	0	0
	Write:							
	Reset:	0	0	0	0	0	0	0
PLL Programming Register (PPG)	Read:	MUL7	MUL6	MUL5	MUL4	VRS7	VRS6	VRS5
	Write:							
	Reset:	0	1	1	0	0	1	1

 = Unimplemented

Figure 8-2. I/O Register Summary

Table 8-1. I/O Register Address Summary

Register	PCTL	PBWC	PPG
Address	\$001C	\$001D	\$001E

8.4.2 Phase-Locked Loop Circuit (PLL)

The PLL is a frequency generator that can operate in either acquisition mode or tracking mode, depending on the accuracy of the output frequency. The PLL can change between acquisition and tracking modes either automatically or manually.

8.4.2.1 Circuits

The PLL consists of these circuits:

- Voltage-controlled oscillator (VCO)
- Modulo VCO frequency divider
- Phase detector

- Loop filter
- Lock detector

The operating range of the VCO is programmable for a wide range of frequencies and for maximum immunity to external noise, including supply and CGMXFC noise. The VCO frequency is bound to a range from roughly one-half to twice the center-of-range frequency, f_{CGMVRS} . Modulating the voltage on the CGMXFC pin changes the frequency within this range. By design, f_{CGMVRS} is equal to the nominal center-of-range frequency, f_{NOM} , (4.9152 MHz) times a linear factor L or $(L)f_{\text{NOM}}$.

CGMRCLK is the PLL reference clock, a buffered version of CGMXCLK. CGMRCLK runs at a frequency, f_{CGMRCLK} , and is fed to the PLL through a buffer. The buffer output is the final reference clock, CGMRDV, running at a frequency $f_{\text{CGMRDV}} = f_{\text{CGMRCLK}}$.

The VCO's output clock, CGMVCLK, running at a frequency f_{CGMVCLK} , is fed back through a programmable modulo divider. The modulo divider reduces the VCO clock by a factor, N . The divider's output is the VCO feedback clock, CGMVDV, running at a frequency $f_{\text{CGMVDV}} = f_{\text{CGMVCLK}}/N$. See **Programming the PLL** for more information.

The phase detector then compares the VCO feedback clock, CGMVDV, with the final reference clock, CGMRDV. A correction pulse is generated based on the phase difference between the two signals. The loop filter then slightly alters the dc voltage on the external capacitor connected to CGMXFC based on the width and direction of the correction pulse. The filter can make fast or slow corrections depending on its mode, as described in **Acquisition and Tracking Modes** on page 129. The value of the external capacitor and the reference frequency determines the speed of the corrections and the stability of the PLL.

The lock detector compares the frequencies of the VCO feedback clock, CGMVDV, and the final reference clock, CGMRDV. Therefore, the speed of the lock detector is directly proportional to the final reference frequency, f_{CGMRDV} . The circuit determines the mode of the PLL and the lock condition based on this comparison.

8.4.2.2 Acquisition and Tracking Modes

The PLL filter is manually or automatically configurable into one of two operating modes:

- Acquisition mode — In acquisition mode, the filter can make large frequency corrections to the VCO. This mode is used at PLL startup or when the PLL has suffered a severe noise hit and the VCO frequency is far off the desired frequency. When in acquisition mode, the \overline{ACQ} bit is clear in the PLL bandwidth control register. See [PLL Bandwidth Control Register](#) on page 139.
- Tracking mode — In tracking mode, the filter makes only small corrections to the frequency of the VCO. PLL jitter is much lower in tracking mode, but the response to noise is also slower. The PLL enters tracking mode when the VCO frequency is nearly correct, such as when the PLL is selected as the base clock source. See [Base Clock Selector Circuit](#) on page 133. The PLL is automatically in tracking mode when it's not in acquisition mode or when the \overline{ACQ} bit is set.

8.4.2.3 Manual and Automatic PLL Bandwidth Modes

The PLL can change the bandwidth or operational mode of the loop filter manually or automatically.

In automatic bandwidth control mode (AUTO = 1), the lock detector automatically switches between acquisition and tracking modes. Automatic bandwidth control mode also is used to determine when the VCO clock, CGMVCLK, is safe to use as the source for the base clock, CGMOUT. See [PLL Bandwidth Control Register](#) on page 139. If PLL CPU interrupt requests are enabled, the software can wait for a PLL CPU interrupt request and then check the LOCK bit. If CPU interrupts are disabled, software can poll the LOCK bit continuously (during PLL startup, usually) or at periodic intervals. In either case, when the LOCK bit is set, the VCO clock is safe to use as the source for the base clock. See [Base Clock Selector Circuit](#) on page 133. If the VCO is selected as the source for the base clock and the LOCK bit is clear, the PLL has suffered a severe noise hit and the software must take appropriate action, depending on the application. See [Interrupts](#) on page 143.

These conditions apply when the PLL is in automatic bandwidth control mode:

- The \overline{ACQ} bit (See **8.6.2 PLL Bandwidth Control Register**.) is a read-only indicator of the mode of the filter. See **Acquisition and Tracking Modes** on page 129.
- The \overline{ACQ} bit is set when the VCO frequency is within a certain tolerance, Δ_{trk} , and is cleared when the VCO frequency is out of a certain tolerance, Δ_{unt} . See **Electrical Specifications** on page 420.
- The LOCK bit is a read-only indicator of the locked state of the PLL.
- The LOCK bit is set when the VCO frequency is within a certain tolerance, Δ_{Lock} , and is cleared when the VCO frequency is out of a certain tolerance, Δ_{unl} . See **Electrical Specifications** on page 420.
- CPU interrupts can occur if enabled ($PLLIE = 1$) when the PLL's lock condition changes, toggling the LOCK bit. See **PLL Control Register** on page 137.

The PLL also can operate in manual mode ($AUTO = 0$). Manual mode is used by systems that do not require an indicator of the lock condition for proper operation. Such systems typically operate well below f_{busmax} and require fast startup. The following conditions apply when in manual mode:

- \overline{ACQ} is a writable control bit that controls the mode of the filter. Before turning on the PLL in manual mode, the \overline{ACQ} bit must be clear.
- Before entering tracking mode ($\overline{ACQ} = 1$), software must wait a given time, t_{acq} (see **Electrical Specifications** on page 420), after turning on the PLL by setting PLLON in the PLL control register (PCTL).
- Software must wait a given time, t_{al} , after entering tracking mode before selecting the PLL as the clock source to CGMOUT ($BCS = 1$).
- The LOCK bit is disabled.
- CPU interrupts from the CGM are disabled.

8.4.2.4 Programming the PLL

Use this 9-step procedure to program the PLL. The table below lists the variables used and their meaning (Please also reference [Figure 8-1](#) on page 126).

Table 8-2. Variable Definitions

Variable	Definition
f_{BUSDES}	Desired Bus Clock Frequency
f_{VCLKDES}	Desired VCO Clock Frequency
f_{CGMRCLK}	Chosen Reference Crystal Frequency
f_{CGMVCLK}	Calculated VCO Clock Frequency
f_{BUS}	Calculated Bus Clock Frequency
f_{NOM}	Nominal VCO Center Frequency
f_{CGMVRS}	Shifted VCO Center Frequency

1. Choose the desired bus frequency, f_{BUSDES} .
Example: $f_{\text{BUSDES}} = 8 \text{ MHz}$
2. Calculate the desired VCO frequency, f_{VCLKDES} .
$$f_{\text{VCLKDES}} = 4 \times f_{\text{BUSDES}}$$

Example: $f_{\text{VCLKDES}} = 4 \times 8 \text{ MHz} = 32 \text{ MHz}$
3. Using a reference frequency, f_{RCLK} , equal to the crystal frequency, calculate the VCO frequency multiplier, N. Round the result to the nearest integer.

$$N = \frac{f_{\text{VCLKDES}}}{f_{\text{CGMRCLK}}}$$

$$\text{Example: } N = \frac{32 \text{ MHz}}{4 \text{ MHz}} = 8$$

4. Calculate the VCO frequency, f_{CGMVCLK} .

$$f_{\text{CGMVCLK}} = N \times f_{\text{CGMRCLK}}$$

$$\text{Example: } f_{\text{CGMVCLK}} = 8 \times 4 \text{ MHz} = 32 \text{ MHz}$$

5. Calculate the bus frequency, f_{BUS} , and compare f_{BUS} with f_{BUSDES} .

$$f_{\text{BUS}} = \frac{f_{\text{CGMVCLK}}}{4}$$

$$\text{Example: } f_{\text{BUS}} = \frac{32 \text{ MHz}}{4} = 8 \text{ MHz}$$

6. If the calculated f_{bus} is not within the tolerance limits of your application, select another f_{BUSDES} or another f_{RCLK} .
7. Using the value 4.9152 MHz for f_{NOM} , calculate the VCO linear range multiplier, L. The linear range multiplier controls the frequency range of the PLL.

$$L = \text{round}\left(\frac{f_{\text{CGMVCLK}}}{f_{\text{NOM}}}\right)$$

$$\text{Example: } L = \frac{32 \text{ MHz}}{4.9152 \text{ MHz}} = 7$$

8. Calculate the VCO center-of-range frequency, f_{CGMVRS} . The center-of-range frequency is the midpoint between the minimum and maximum frequencies attainable by the PLL.

$$f_{\text{CGMVRS}} = L \times f_{\text{NOM}}$$

$$\text{Example: } f_{\text{CGMVRS}} = 7 \times 4.9152 \text{ MHz} = 34.4 \text{ MHz}$$

NOTE: For proper operation, $|f_{\text{CGMVRS}} - f_{\text{CGMVCLK}}| \leq \frac{f_{\text{NOM}}}{2}$.

Exceeding the recommended maximum bus frequency or VCO frequency can crash the MCU.

9. Program the PLL registers accordingly:
 - a. In the upper four bits of the PLL programming register (PPG), program the binary equivalent of N.
 - b. In the lower four bits of the PLL programming register (PPG), program the binary equivalent of L.

8.4.2.5 Special Programming Exceptions

The programming method described in [Programming the PLL](#) on page 131, does not account for two possible exceptions. A value of 0 for N or L is meaningless when used in the equations given. To account for these exceptions:

- A 0 value for N is interpreted the same as a value of 1.
- A 0 value for L disables the PLL and prevents its selection as the source for the base clock. See [Base Clock Selector Circuit](#) on page 133.

8.4.3 Base Clock Selector Circuit

This circuit is used to select either the crystal clock, CGMXCLK, or the VCO clock, CGMVCLK, as the source of the base clock, CGMOUT. The two input clocks go through a transition control circuit that waits up to three CGMXCLK cycles and three CGMVCLK cycles to change from one clock source to the other. During this time, CGMOUT is held in stasis. The output of the transition control circuit is then divided by two to correct the duty cycle. Therefore, the bus clock frequency, which is one-half of the base clock frequency, is one-fourth the frequency of the selected clock (CGMXCLK or CGMVCLK).

The BCS bit in the PLL control register (PCTL) selects which clock drives CGMOUT. The VCO clock cannot be selected as the base clock source if the PLL is not turned on. The PLL cannot be turned off if the VCO clock is selected. The PLL cannot be turned on or off simultaneously with the selection or deselection of the VCO clock. The VCO clock also cannot be selected as the base clock source if the factor L is programmed to a 0. This value would set up a condition inconsistent with the operation of the PLL, so that the PLL would be disabled and the crystal clock would be forced as the source of the base clock.

8.4.4 CGM External Connections

In its typical configuration, the CGM requires seven external components. Five of these are for the crystal oscillator and two are for the PLL.

The crystal oscillator is normally connected in a Pierce oscillator configuration, as shown in [Figure 8-3](#). [Figure 8-3](#) shows only the logical representation of the internal components and may not represent actual circuitry. The oscillator configuration uses five components:

- Crystal, X_1
- Fixed capacitor, C_1
- Tuning capacitor, C_2 (can also be a fixed capacitor)
- Feedback resistor, R_B
- Series resistor, R_S (optional)

The series resistor (R_S) may not be required for all ranges of operation, especially with high-frequency crystals. Refer to the crystal manufacturer's data for more information.

[Figure 8-3](#) also shows the external components for the PLL:

- Bypass capacitor, C_{BYP}
- Filter capacitor, C_F

Routing should be done with great care to minimize signal cross talk and noise. (See [Acquisition/Lock Time Specifications](#) on page 144 for routing information and more information on the filter capacitor's value and its effects on PLL performance).

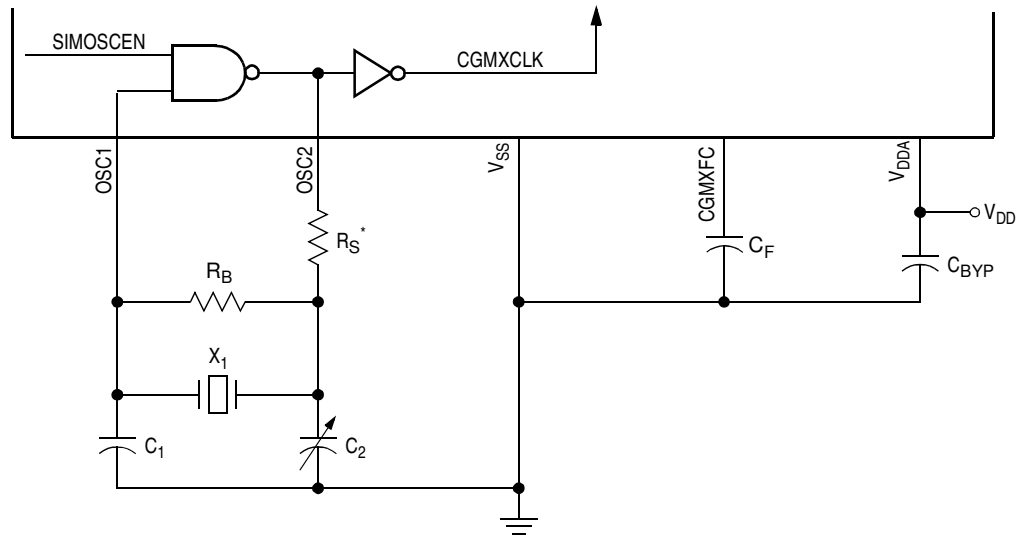

* R_S can be 0 (shorted) when used with higher-frequency crystals. Refer to manufacturer's data.

Figure 8-3. CGM External Connections

8.5 I/O Signals

The following paragraphs describe the CGM input/output (I/O) signals.

8.5.1 Crystal Amplifier Input Pin (OSC1)

The OSC1 pin is an input to the crystal oscillator amplifier.

8.5.2 Crystal Amplifier Output Pin (OSC2)

The OSC2 pin is the output of the crystal oscillator inverting amplifier.

8.5.3 External Filter Capacitor Pin (CGMXFC)

The CGMXFC pin is required by the loop filter to filter out phase corrections. A small external capacitor is connected to this pin.

NOTE: To prevent noise problems, C_F should be placed as close to the CGMXFC pin as possible with minimum routing distances and no routing of other signals across the C_F connection.

8.5.4 Analog Power Pin (V_{DDA})

V_{DDA} is a power pin used by the analog portions of the PLL. Connect the V_{DDA} pin to the same voltage potential as the V_{DD} pin.

NOTE: *Route V_{DDA} carefully for maximum noise immunity and place bypass capacitors as close as possible to the package.*

8.5.5 Oscillator Enable Signal (SIMOSCEN)

The SIMOSCEN signal enables the oscillator and PLL.

8.5.6 Crystal Output Frequency Signal (CGMXCLK)

CGMXCLK is the crystal oscillator output signal. It runs at the full speed of the crystal ($f_{CGMXCLK}$) and comes directly from the crystal oscillator circuit. [Figure 8-3](#) shows only the logical relation of CGMXCLK to OSC1 and OSC2 and may not represent the actual circuitry. The duty cycle of CGMXCLK is unknown and may depend on the crystal and other external factors. Also, the frequency and amplitude of CGMXCLK can be unstable at startup.

8.5.7 CGM Base Clock Output (CGMOUT)

CGMOUT is the clock output of the CGM. This signal is used to generate the MCU clocks. CGMOUT is a 50% duty cycle clock running at twice the bus frequency. CGMOUT is software programmable to be either the oscillator output, CGMXCLK, divided by two or the VCO clock, CGMVCLK, divided by two.

8.5.8 CGM CPU Interrupt (CGMINT)

CGMINT is the CPU interrupt signal generated by the PLL lock detector.

8.6 CGM Registers

Three registers control and monitor operation of the CGM:

- PLL control register (PCTL)
- PLL bandwidth control register (PBWC)
- PLL programming register (PPG)

8.6.1 PLL Control Register

The PLL control register contains the interrupt enable and flag bits, the on/off switch, and the base clock selector bit.

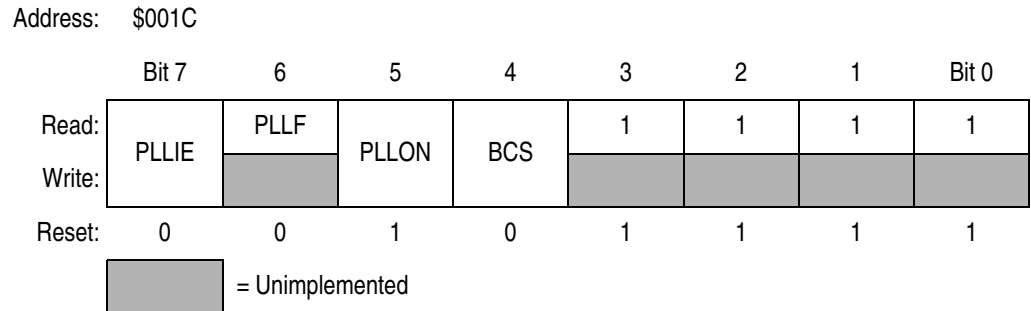

Figure 8-4. PLL Control Register (PCTL)

PLLIE — PLL Interrupt Enable Bit

This read/write bit enables the PLL to generate a CPU interrupt request when the LOCK bit toggles, setting the PLL flag, PLLF. When the AUTO bit in the PLL bandwidth control register (PBWC) is clear, PLLIE cannot be written and reads as logic 0. Reset clears the PLLIE bit.

- 1 = PLL CPU interrupt requests enabled
- 0 = PLL CPU interrupt requests disabled

PLLF — PLL Flag Bit

This read-only bit is set whenever the LOCK bit toggles. PLLF generates a CPU interrupt request if the PLLIE bit also is set. PLLF always reads as logic 0 when the AUTO bit in the PLL bandwidth control register (PBWC) is clear. Clear the PLLF bit by reading the PLL control register. Reset clears the PLLF bit.

1 = Change in lock condition

0 = No change in lock condition

NOTE: *Do not inadvertently clear the PLLF bit. Be aware that any read or read-modify-write operation on the PLL control register clears the PLLF bit.*

PLLON — PLL On Bit

This read/write bit activates the PLL and enables the VCO clock, CGMVCLK. PLLON cannot be cleared if the VCO clock is driving the base clock, CGMOUT (BCS = 1). See [Base Clock Selector Circuit](#) on page 133. Reset sets this bit so that the loop can stabilize as the MCU is powering up.

1 = PLL on

0 = PLL off

BCS — Base Clock Select Bit

This read/write bit selects either the crystal oscillator output, CGMXCLK, or the VCO clock, CGMVCLK, as the source of the CGM output, CGMOUT. CGMOUT frequency is one-half the frequency of the selected clock. BCS cannot be set while the PLLON bit is clear. After toggling BCS, it may take up to three CGMXCLK and three CGMVCLK cycles to complete the transition from one source clock to the other. During the transition, CGMOUT is held in stasis. See [Base Clock Selector Circuit](#) on page 133. Reset and the STOP instruction clear the BCS bit.

1 = CGMVCLK divided by two drives CGMOUT

0 = CGMXCLK divided by two drives CGMOUT

NOTE: *PLLON and BCS have built-in protection that prevents the base clock selector circuit from selecting the VCO clock as the source of the base clock if the PLL is off. Therefore, PLLON cannot be cleared when BCS is set, and BCS cannot be set when PLLON is clear. If the PLL is off*

(*PLLON = 0*), selecting *CGMVCLK* requires two writes to the PLL control register. See **Base Clock Selector Circuit** on page 133.

PCTL3–PCTL0 — Unimplemented

These bits provide no function and always read as logic 1s.

8.6.2 PLL Bandwidth Control Register

The PLL bandwidth control register:

- Selects automatic or manual (software-controlled) bandwidth control mode
- Indicates when the PLL is locked
- In automatic bandwidth control mode, indicates when the PLL is in acquisition or tracking mode
- In manual operation, forces the PLL into acquisition or tracking mode

Address: \$001D

	Bit 7	6	5	4	3	2	1	Bit 0
Read:	AUTO	LOCK	$\overline{\text{ACQ}}$	XLD	0	0	0	0
Write:								
Reset:	0	0	0	0	0	0	0	0

= Unimplemented

Figure 8-5. PLL Bandwidth Control Register (PBWC)

AUTO — Automatic Bandwidth Control Bit

This read/write bit selects automatic or manual bandwidth control. When initializing the PLL for manual operation (AUTO = 0), clear the \overline{ACQ} bit before turning on the PLL. Reset clears the AUTO bit.

1 = Automatic bandwidth control

0 = Manual bandwidth control

LOCK — Lock Indicator Bit

When the AUTO bit is set, LOCK is a read-only bit that becomes set when the VCO clock, CGMVCLK, is locked (running at the programmed frequency). When the AUTO bit is clear, LOCK reads as logic 0 and has no meaning. Reset clears the LOCK bit.

1 = VCO frequency correct or locked

0 = VCO frequency incorrect or unlocked

\overline{ACQ} — Acquisition Mode Bit

When the AUTO bit is set, \overline{ACQ} is a read-only bit that indicates whether the PLL is in acquisition mode or tracking mode. When the AUTO bit is clear, \overline{ACQ} is a read/write bit that controls whether the PLL is in acquisition or tracking mode.

In automatic bandwidth control mode (AUTO = 1), the last-written value from manual operation is stored in a temporary location and is recovered when manual operation resumes. Reset clears this bit, enabling acquisition mode.

1 = Tracking mode

0 = Acquisition mode

XLD — Crystal Loss Detect Bit

When the VCO output, CGMVCLK, is driving CGMOUT, this read/write bit can indicate whether the crystal reference frequency is active or not.

1 = Crystal reference not active

0 = Crystal reference active

To check the status of the crystal reference, do the following:

1. Write a logic 1 to XLD.
2. Wait $N \times 4$ cycles. N is the VCO frequency multiplier.
3. Read XLD.

The crystal loss detect function works only when the BCS bit is set, selecting CGMVCLK to drive CGMOUT. When BCS is clear, XLD always reads as logic 0.

Bits 3–0 — Reserved for Test

These bits enable test functions not available in user mode. To ensure software portability from development systems to user applications, software should write 0s to bits 3–0 when writing to PBWC.

8.6.3 PLL Programming Register

The PLL programming register contains the programming information for the modulo feedback divider and the programming information for the hardware configuration of the VCO.

Address: \$001E

	Bit 7	6	5	4	3	2	1	Bit 0
Read:	MUL7	MUL6	MUL5	MUL4	VRS7	VRS6	VRS5	VRS4
Write:								
Reset:	0	1	1	0	0	1	1	0

Figure 8-6. PLL Programming Register (PPG)

MUL7–MUL4 — Multiplier Select Bits

These read/write bits control the modulo feedback divider that selects the VCO frequency multiplier, N. (See [Circuits](#) on page 127 and [Programming the PLL](#) on page 131). A value of \$0 in the multiplier select bits configures the modulo feedback divider the same as a value of \$1. Reset initializes these bits to \$6 to give a default multiply value of 6.

Table 8-3. VCO Frequency Multiplier (N) Selection

MUL7:MUL6:MUL5:MUL4	VCO Frequency Multiplier (N)
0000	1
0001	1
0010	2
0011	3
↓	↓
1101	13
1110	14
1111	15

NOTE: *The multiplier select bits have built-in protection that prevents them from being written when the PLL is on (PLLON = 1).*

VRS7–VRS4 — VCO Range Select Bits

These read/write bits control the hardware center-of-range linear multiplier L, which controls the hardware center-of-range frequency, f_{VRS} . (See [Circuits](#) on page 127, [Programming the PLL](#) on page 131, and [PLL Control Register](#) on page 137.) VRS7–VRS4 cannot be written when the PLLON bit in the PLL control register (PCTL) is set. See [Special Programming Exceptions](#) on page 133. A value of \$0 in the VCO range select bits disables the PLL and clears the BCS bit in the PCTL. (See [Base Clock Selector Circuit](#) on page 133 and [Special Programming Exceptions](#) on page 133 for more information.) Reset initializes the bits to \$6 to give a default range multiply value of 6.

NOTE: *The VCO range select bits have built-in protection that prevents them from being written when the PLL is on (PLLON = 1) and prevents selection of the VCO clock as the source of the base clock (BCS = 1) if the VCO range select bits are all clear.*

The VCO range select bits must be programmed correctly. Incorrect programming can result in failure of the PLL to achieve lock.

8.7 Interrupts

When the AUTO bit is set in the PLL bandwidth control register (PBWC), the PLL can generate a CPU interrupt request every time the LOCK bit changes state. The PLLIE bit in the PLL control register (PCTL) enables CPU interrupt requests from the PLL. PLLF, the interrupt flag in the PCTL, becomes set whether CPU interrupt requests are enabled or not. When the AUTO bit is clear, CPU interrupt requests from the PLL are disabled and PLLF reads as logic 0.

Software should read the LOCK bit after a PLL CPU interrupt request to see if the request was due to an entry into lock or an exit from lock. When the PLL enters lock, the VCO clock, CGMVCLK, divided by two can be selected as the CGMOUT source by setting BCS in the PCTL. When the PLL exits lock, the VCO clock frequency is corrupt, and appropriate precautions should be taken. If the application is not frequency sensitive, CPU interrupt requests should be disabled to prevent PLL interrupt service routines from impeding software performance or from exceeding stack limitations.

NOTE: *Software can select the CGMVCLK divided by two as the CGMOUT source even if the PLL is not locked (LOCK = 0). Therefore, software should make sure the PLL is locked before setting the BCS bit.*

8.8 Low-Power Modes

The WAIT and STOP instructions put the MCU in low power-consumption standby modes.

8.8.1 Wait Mode

The CGM remains active in wait mode. Before entering wait mode, software can disengage and turn off the PLL by clearing the BCS and PLLON bits in the PLL control register (PCTL). Less power-sensitive applications can disengage the PLL without turning it off. Applications that require the PLL to wake the MCU from wait mode also can deselect the PLL output without turning off the PLL.

8.8.2 Stop Mode

The STOP instruction disables the CGM and holds low all CGM outputs (CGMXCLK, CGMOUT, and CGMINT).

If CGMOUT is being driven by CGMVCLK and a STOP instruction is executed; the PLL will clear the BCS bit in the PLL control register, causing CGMOUT to be driven by CGMXCLK. When the MCU recovers from STOP, the crystal clock divided by two drives CGMOUT and BCS remains clear.

8.9 CGM During Break Interrupts

The BCFE bit in the break flag control register (BFCR) enables software to clear status bits during the break state. See [Break Module \(BRK\)](#) on page 157.

To allow software to clear status bits during a break interrupt, write a logic 1 to the BCFE bit. If a status bit is cleared during the break state, it remains cleared when the MCU exits the break state.

To protect the PLLF bit during the break state, write a logic 0 to the BCFE bit. With BCFE at logic 0 (its default state), software can read and write the PLL control register during the break state without affecting the PLLF bit.

8.10 Acquisition/Lock Time Specifications

The acquisition and lock times of the PLL are, in many applications, the most critical PLL design parameters. Proper design and use of the PLL ensures the highest stability and lowest acquisition/lock times.

8.10.1 Acquisition/Lock Time Definitions

Typical control systems refer to the acquisition time or lock time as the reaction time, within specified tolerances, of the system to a step input. In a PLL, the step input occurs when the PLL is turned on or when it suffers a noise hit. The tolerance is usually specified as a percent of the

step input or when the output settles to the desired value plus or minus a percent of the frequency change. Therefore, the reaction time is constant in this definition, regardless of the size of the step input. For example, consider a system with a 5% acquisition time tolerance. If a command instructs the system to change from 0 Hz to 1 MHz, the acquisition time is the time taken for the frequency to reach $1\text{ MHz} \pm 50\text{ kHz}$. Fifty kHz = 5% of the 1-MHz step input. If the system is operating at 1 MHz and suffers a -100 kHz noise hit, the acquisition time is the time taken to return from 900 kHz to $1\text{ MHz} \pm 5\text{ kHz}$. Five kHz = 5% of the 100-kHz step input.

Other systems refer to acquisition and lock times as the time the system takes to reduce the error between the actual output and the desired output to within specified tolerances. Therefore, the acquisition or lock time varies according to the original error in the output. Minor errors may not even be registered. Typical PLL applications prefer to use this definition because the system requires the output frequency to be within a certain tolerance of the desired frequency regardless of the size of the initial error.

The discrepancy in these definitions makes it difficult to specify an acquisition or lock time for a typical PLL. Therefore, the definitions for acquisition and lock times for this module are:

- Acquisition time, t_{acq} , is the time the PLL takes to reduce the error between the actual output frequency and the desired output frequency to less than the tracking mode entry tolerance, Δ_{trk} . Acquisition time is based on an initial frequency error, $(f_{\text{des}} - f_{\text{orig}})/f_{\text{des}}$, of not more than $\pm 100\%$. In automatic bandwidth control mode (see [Manual and Automatic PLL Bandwidth Modes](#) on page 129), acquisition time expires when the $\overline{\text{ACQ}}$ bit becomes set in the PLL bandwidth control register (PBWC).
- Lock time, t_{lock} , is the time the PLL takes to reduce the error between the actual output frequency and the desired output frequency to less than the lock mode entry tolerance, Δ_{lock} . Lock time is based on an initial frequency error, $(f_{\text{des}} - f_{\text{orig}})/f_{\text{des}}$, of not more than $\pm 100\%$. In automatic bandwidth control mode, lock time

expires when the LOCK bit becomes set in the PLL bandwidth control register (PBWC). (See [Manual and Automatic PLL Bandwidth Modes](#) on page 129).

Obviously, the acquisition and lock times can vary according to how large the frequency error is and may be shorter or longer in many cases.

8.10.2 Parametric Influences on Reaction Time

Acquisition and lock times are designed to be as short as possible while still providing the highest possible stability. These reaction times are not constant, however. Many factors directly and indirectly affect the acquisition time.

The most critical parameter which affects the reaction times of the PLL is the reference frequency, f_{CGMRDV} (please reference [Figure 8-1](#)). This frequency is the input to the phase detector and controls how often the PLL makes corrections. For stability, the corrections must be small compared to the desired frequency, so several corrections are required to reduce the frequency error. Therefore, the slower the reference the longer it takes to make these corrections. This parameter is also under user control via the choice of crystal frequency f_{CGMXCLK} .

Another critical parameter is the external filter capacitor. The PLL modifies the voltage on the VCO by adding or subtracting charge from this capacitor. Therefore, the rate at which the voltage changes for a given frequency error (thus a change in charge) is proportional to the capacitor size. The size of the capacitor also is related to the stability of the PLL. If the capacitor is too small, the PLL cannot make small enough adjustments to the voltage and the system cannot lock. If the capacitor is too large, the PLL may not be able to adjust the voltage in a reasonable time. See [Choosing a Filter Capacitor](#) on page 147.

Also important is the operating voltage potential applied to V_{DDA} . The power supply potential alters the characteristics of the PLL. A fixed value is best. Variable supplies, such as batteries, are acceptable if they vary within a known range at very slow speeds. Noise on the power supply is not acceptable, because it causes small frequency errors which continually change the acquisition time of the PLL.

Temperature and processing also can affect acquisition time because the electrical characteristics of the PLL change. The part operates as specified as long as these influences stay within the specified limits. External factors, however, can cause drastic changes in the operation of the PLL. These factors include noise injected into the PLL through the filter capacitor, filter capacitor leakage, stray impedances on the circuit board, and even humidity or circuit board contamination.

8.10.3 Choosing a Filter Capacitor

As described in [Parametric Influences on Reaction Time](#) on page 146, the external filter capacitor, C_F , is critical to the stability and reaction time of the PLL. The PLL is also dependent on reference frequency and supply voltage. The value of the capacitor must, therefore, be chosen with supply potential and reference frequency in mind. For proper operation, the external filter capacitor must be chosen according to this equation:

$$C_F = C_{\text{fact}} \left(\frac{V_{\text{DDA}}}{f_{\text{CGMRDV}}} \right)$$

For acceptable values of C_{fact} , (see [Electrical Specifications](#) on page 420). For the value of V_{DDA} , choose the voltage potential at which the MCU is operating. If the power supply is variable, choose a value near the middle of the range of possible supply values.

This equation does not always yield a commonly available capacitor size, so round to the nearest available size. If the value is between two different sizes, choose the higher value for better stability. Choosing the lower size may seem attractive for acquisition time improvement, but the PLL may become unstable. Also, always choose a capacitor with a tight tolerance ($\pm 20\%$ or better) and low dissipation.

8.10.4 Reaction Time Calculation

The actual acquisition and lock times can be calculated using the equations below. These equations yield nominal values under the following conditions:

- Correct selection of filter capacitor, C_F (see [Choosing a Filter Capacitor](#) on page 147).
- Room temperature operation
- Negligible external leakage on CGMXFC
- Negligible noise

The K factor in the equations is derived from internal PLL parameters. K_{acq} is the K factor when the PLL is configured in acquisition mode, and K_{trk} is the K factor when the PLL is configured in tracking mode. (See [Acquisition and Tracking Modes](#) on page 129).

$$t_{acq} = \left(\frac{V_{DDA}}{f_{CGMRDV}} \right) \left(\frac{8}{K_{ACQ}} \right)$$

$$t_{al} = \left(\frac{V_{DDA}}{f_{CGMRDV}} \right) \left(\frac{4}{K_{TRK}} \right)$$

$$t_{Lock} = t_{ACQ} + t_{AL}$$

Note the inverse proportionality between the lock time and the reference frequency.

In automatic bandwidth control mode, the acquisition and lock times are quantized into units based on the reference frequency. (See [Manual and Automatic PLL Bandwidth Modes](#) on page 129). A certain number of clock cycles, n_{ACQ} , is required to ascertain that the PLL is within the tracking mode entry tolerance, Δ_{TRK} , before exiting acquisition mode. A certain number of clock cycles, n_{TRK} , is required to ascertain that the PLL is within the lock mode entry tolerance, Δ_{Lock} . Therefore, the acquisition time, t_{ACQ} , is an integer multiple of n_{ACQ}/f_{CGMRDV} , and the acquisition to lock time, t_{AL} , is an integer multiple of n_{TRK}/f_{CGMRDV} . Also, since the average frequency over the entire measurement period must be within the specified tolerance, the total time usually is longer than t_{Lock} as calculated above.

In manual mode, it is usually necessary to wait considerably longer than t_{Lock} before selecting the PLL clock (see **Base Clock Selector Circuit** on page 133), because the factors described in **Parametric Influences on Reaction Time** on page 146, may slow the lock time considerably.

When defining a limit in software for the maximum lock time, the value must allow for variation due to all of the factors mentioned in this section, especially due to the C_F capacitor and application specific influences.

The calculated lock time is only an indication and it is the customer's responsibility to allow enough of a guard band for their application. Prior to finalizing any software and while determining the maximum lock time, take into account all device to device differences. Typically, applications set the maximum lock time as an order of magnitude higher than the measured value. This is considered sufficient for all such device to device variation.

Motorola recommends measuring the lock time of the application system by utilizing dedicated software, running in FLASH, EEPROM or RAM. This should toggle a port pin when the PLL is first configured and switched on, then again when it goes from acquisition to lock mode and finally again when the PLL lock bit is set. The resultant waveform can be captured on an oscilloscope and used to determine the typical lock time for the microcontroller and the associated external application circuit.

e.g.

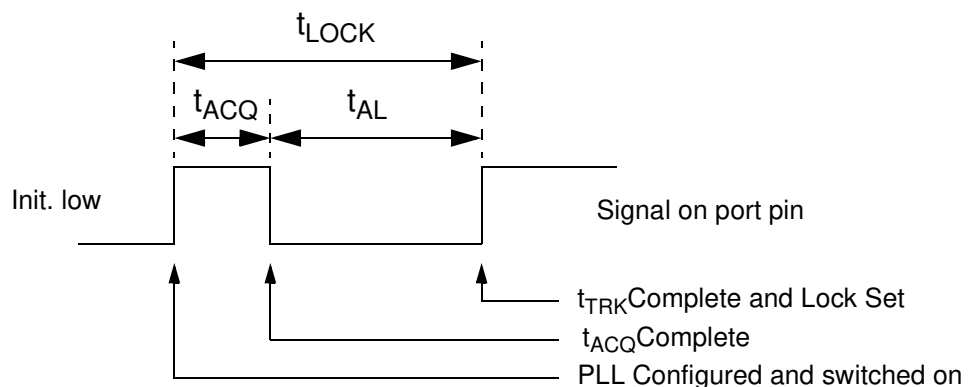

NOTE: The filter capacitor should be fully discharged prior to making any measurements.

Section 9. Configuration Register (CONFIG-1)

9.1 Contents

9.2	Introduction	151
9.3	Functional Description	151

9.2 Introduction

This section describes the configuration register (CONFIG-1), which contains bits that configure these options:

- Resets caused by the LVI module
- Power to the LVI module
- LVI enabled during stop mode
- Stop mode recovery time (32 CGMXCLK cycles or 4096 CGMXCLK cycles)
- Computer operating properly module (COP)
- Stop instruction enable/disable.

9.3 Functional Description

The configuration register is a write-once register. Out of reset, the configuration register will read the default value. Once the register is written, further writes will have no effect until a reset occurs.

NOTE: *If the LVI module and the LVI reset signal are enabled, a reset occurs when V_{DD} falls to a voltage, LVI_{TRIPF} , and remains at or below that level*

Configuration Register (CONFIG-1)

for at least nine consecutive CPU cycles. Once an LVI reset occurs, the MCU remains in reset until V_{DD} rises to a voltage, LVI_{TRIPR} .

Address: \$001F

	Bit 7	6	5	4	3	2	1	Bit 0
Read:	LVISTOP	R	LVIRST	LVIPWR	SSREC	COPL	STOP	COPD
Write:								
Reset:	0	1	1	1	0	0	0	0

R

 = Reserved

Figure 9-1. Configuration Register (CONFIG-1)

LVISTOP — LVI Stop Mode Enable Bit

LVISTOP enables the LVI module in stop mode. (See [Low Voltage Inhibit \(LVI\)](#) on page 181).

- 1 = LVI enabled during stop mode
- 0 = LVI disabled during stop mode

NOTE: To have the LVI enabled in stop mode, the LVIPWR must be at a logic 1 and the LVISTOP bit must be at a logic 1. Take note that by enabling the LVI in stop mode, the stop I_{DD} current will be higher.

LVIRST — LVI Reset Enable Bit

LVIRST enables the reset signal from the LVI module. (See [Low Voltage Inhibit \(LVI\)](#) on page 181).

- 1 = LVI module resets enabled
- 0 = LVI module resets disabled

LVIPWR — LVI Power Enable Bit

LVIPWR enables the LVI module. (See [Low Voltage Inhibit \(LVI\)](#) on page 181).

- 1 = LVI module power enabled
- 0 = LVI module power disabled

SSREC — Short Stop Recovery Bit

SSREC enables the CPU to exit stop mode with a delay of 32 CGMXCLK cycles instead of a 4096-CGMXCLK cycle delay. (See [System Integration Module \(SIM\)](#) on page 101).

- 1 = Stop mode recovery after 32 CGMXCLK cycles
- 0 = Stop mode recovery after 4096 CGMXCLK cycles

NOTE: *If using an external crystal oscillator, do not set the SSREC bit.*

COPL — COP Long Timeout

COPL enables the shorter COP timeout period. (See [Computer Operating Properly \(COP\)](#) on page 175).

- 1 = COP timeout period is $2^{13} - 2^4$ CGMXCLK cycles
- 0 = COP timeout period is $2^{18} - 2^4$ CGMXCLK cycles

STOP — STOP Instruction Enable Bit

STOP enables the STOP instruction.

- 1 = STOP instruction enabled
- 0 = STOP instruction treated as illegal opcode

COPD — COP Disable Bit

COPD disables the COP module. (See [Computer Operating Properly \(COP\)](#) on page 175).

- 1 = COP module disabled
- 0 = COP module enabled

Configuration Register (CONFIG-1)

Section 10. Configuration Register (CONFIG-2)

10.1 Contents

10.2 Introduction155

10.3 Functional Description155

10.2 Introduction

This section describes the configuration register (CONFIG-2). This register contains bits that configure these options:

- Configures the device to either the MC68HC08AZxx emulator or the MC68HC08ASxx emulator

10.3 Functional Description

The configuration register is a write-once register. Out of reset, the configuration register will read the default. Once the register is written, further writes will have no effect until a reset occurs.

Address: \$FE09

	Bit 7	6	5	4	3	2	1	Bit 0
Read:	EEDIV	R	R	R	AS32A	R	R	R
Write:	CLK							
Reset:	0	0	0	1	1	0	0	0

Figure 10-1. Configuration Register (CONFIG-2)

Configuration Register (CONFIG-2)

EEDIVCLK — EEPROM Timebase Divider Clock select bit

This bit selects the reference clock source for the EEPROM timebase divider module.

1 = EExDIV clock input is driven by internal bus clock

0 = EExDIV clock input is driven by CGMXCLK

AS32A— Device Indicator bit

This bit is used to distinguish MC68HC908AS60A from older non-'A' suffix versions.

1 = 'A' version

0 = Non-'A' version

Section 11. Break Module (BRK)

11.1 Contents

11.2	Introduction	157
11.3	Features	157
11.4	Functional Description	158
11.4.1	Flag Protection During Break Interrupts	159
11.4.2	CPU During Break Interrupts	160
11.4.3	TIM During Break Interrupts	160
11.4.4	COP During Break Interrupts	160
11.5	Low-Power Modes	160
11.5.1	Wait Mode	160
11.5.2	Stop Mode	161
11.6	Break Module Registers	161
11.6.1	Break Status and Control Register	161
11.6.2	Break Address Registers	162

11.2 Introduction

The break module can generate a break interrupt that stops normal program flow at a defined address to enter a background program.

11.3 Features

- Accessible I/O Registers during Break Interrupts
- CPU-Generated Break Interrupts
- Software-Generated Break Interrupts
- COP Disabling during Break Interrupts

11.4 Functional Description

When the internal address bus matches the value written in the break address registers, the break module issues a breakpoint signal to the CPU. The CPU then loads the instruction register with a software interrupt instruction (SWI) after completion of the current CPU instruction. The program counter vectors to \$FFFC and \$FFFD (\$FEFC and \$FEFD in monitor mode).

The following events can cause a break interrupt to occur:

- A CPU-generated address (the address in the program counter) matches the contents of the break address registers.
- Software writes a logic 1 to the BRKA bit in the break status and control register.

When a CPU-generated address matches the contents of the break address registers, the break interrupt begins after the CPU completes its current instruction. A return-from-interrupt instruction (RTI) in the break routine ends the break interrupt and returns the MCU to normal operation. **Figure 11-1** shows the structure of the break module.

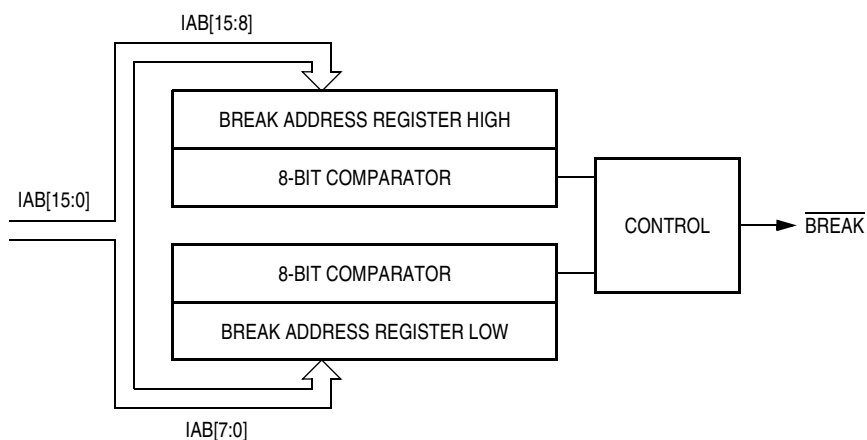

Figure 11-1. Break Module Block Diagram

Register Name	Bit 7	6	5	4	3	2	1	Bit 0	
Break Address Register High (BRKH)	Read:	Bit 15	14	13	12	11	10	9	Bit 8
	Write:								
	Reset:	0	0	0	0	0	0	0	0
Break Address Register Low (BRKL)	Read:	Bit 7	6	5	4	3	2	1	Bit 0
	Write:								
	Reset:	0	0	0	0	0	0	0	0
Break Status and Control Register (BSCR)	Read:	BRKE	BRKA	0	0	0	0	0	0
	Write:								
	Reset:	0	0	0	0	0	0	0	0

= Unimplemented R = Reserved

Figure 11-2. I/O Register Summary

Table 11-1. I/O Register Address Summary

Register	BRKH	BRKL	BSCR
Address	\$FE0C	\$FE0D	\$FE0E

11.4.1 Flag Protection During Break Interrupts

The BCFE bit in the break flag control register (BFCR) enables software to clear status bits during the break state.

11.4.2 CPU During Break Interrupts

The CPU starts a break interrupt by:

- Loading the instruction register with the SWI instruction
- Loading the program counter with \$FFFC:\$FFFD (\$FEFC:\$FEFD in monitor mode)

The break interrupt begins after completion of the CPU instruction in progress. If the break address register match occurs on the last cycle of a CPU instruction, the break interrupt begins immediately.

11.4.3 TIM During Break Interrupts

A break interrupt stops the timer counter.

11.4.4 COP During Break Interrupts

The COP is disabled during a break interrupt when V_{Hi} is present on the \overline{RST} pin.

11.5 Low-Power Modes

The WAIT and STOP instructions put the MCU in low power-consumption standby modes.

11.5.1 Wait Mode

If enabled, the break module is active in wait mode. The SIM break wait bit (BW) in the SIM break status register indicates whether wait was exited by a break interrupt. If so, the user can modify the return address on the stack by subtracting one from it. (See [SIM Break Status Register](#) on page 120).

11.5.2 Stop Mode

The break module is inactive in stop mode. The STOP instruction does not affect break module register states.

11.6 Break Module Registers

These registers control and monitor operation of the break module:

- Break address register high (BRKH)
- Break address register low (BRKL)
- Break status and control register (BSCR)

11.6.1 Break Status and Control Register

The break status and control register contains break module enable and status bits.

Address: \$FE0E

	Bit 7	6	5	4	3	2	1	Bit 0
Read:	BRKE	BRKA	0	0	0	0	0	0
Write:								
Reset:	0	0	0	0	0	0	0	0

= Unimplemented

Figure 11-3. Break Status and Control Register (BSCR)

BRKE — Break Enable Bit

This read/write bit enables breaks on break address register matches. Clear BRKE by writing a logic 0 to bit 7. Reset clears the BRKE bit.

- 1 = Breaks enabled on 16-bit address match
- 0 = Breaks disabled on 16-bit address match

BRKA — Break Active Bit

This read/write status and control bit is set when a break address match occurs. Writing a logic 1 to BRKA generates a break interrupt. Clear BRKA by writing a logic 0 to it before exiting the break routine. Reset clears the BRKA bit.

1 = (When read) Break address match

0 = (When read) No break address match

11.6.2 Break Address Registers

The break address registers contain the high and low bytes of the desired breakpoint address. Reset clears the break address registers.

Register:	BRKH	BRKL						
Address:	\$FE0C	\$FE0D						
	Bit 7	6	5	4	3	2	1	Bit 0
Read:	Bit 15	14	13	12	11	10	9	Bit 8
Write:								
Reset:	0	0	0	0	0	0	0	0
Read:	Bit 7	6	5	4	3	2	1	Bit 0
Write:								
Reset:	0	0	0	0	0	0	0	0

Figure 11-4. Break Address Registers (BRKH and BRKL)

Section 12. Monitor ROM (MON)

12.1 Contents

12.2	Introduction	163
12.3	Features	163
12.4	Functional Description	164
12.4.1	Entering Monitor Mode	166
12.4.2	Data Format	167
12.4.3	Echoing	168
12.4.4	Break Signal	168
12.4.5	Commands	168
12.4.6	MC68HC908AS60A Baud Rate	172
12.4.7	Security	173

12.2 Introduction

This section describes the monitor ROM (MON). The monitor ROM allows complete testing of the MCU through a single-wire interface with a host computer.

12.3 Features

Features of the monitor ROM include:

- Normal User-Mode Pin Functionality
- One Pin Dedicated to Serial Communication between Monitor ROM and Host Computer
- Standard Mark/Space Non-Return-to-Zero (NRZ) Communication with Host Computer

- Up to 28.8 kBaud Communication with Host Computer
- Execution of Code in RAM or FLASH
- FLASH Security
- FLASH Programming

12.4 Functional Description

Monitor ROM receives and executes commands from a host computer. **Figure 12-1** shows a sample circuit used to enter monitor mode and communicate with a host computer via a standard RS-232 interface.

While simple monitor commands can access any memory address, the MC68HC908AS60A has a FLASH security feature to prevent external viewing of the contents of FLASH. Proper procedures must be followed to verify FLASH content. Access to the FLASH is denied to unauthorized users of customer specified software (see **Security** on page 173).

In monitor mode, the MCU can execute host-computer code in RAM while all MCU pins except PTA0 retain normal operating mode functions. All communication between the host computer and the MCU is through the PTA0 pin. A level-shifting and multiplexing interface is required between PTA0 and the host computer. PTA0 is used in a wired-OR configuration and requires a pullup resistor.

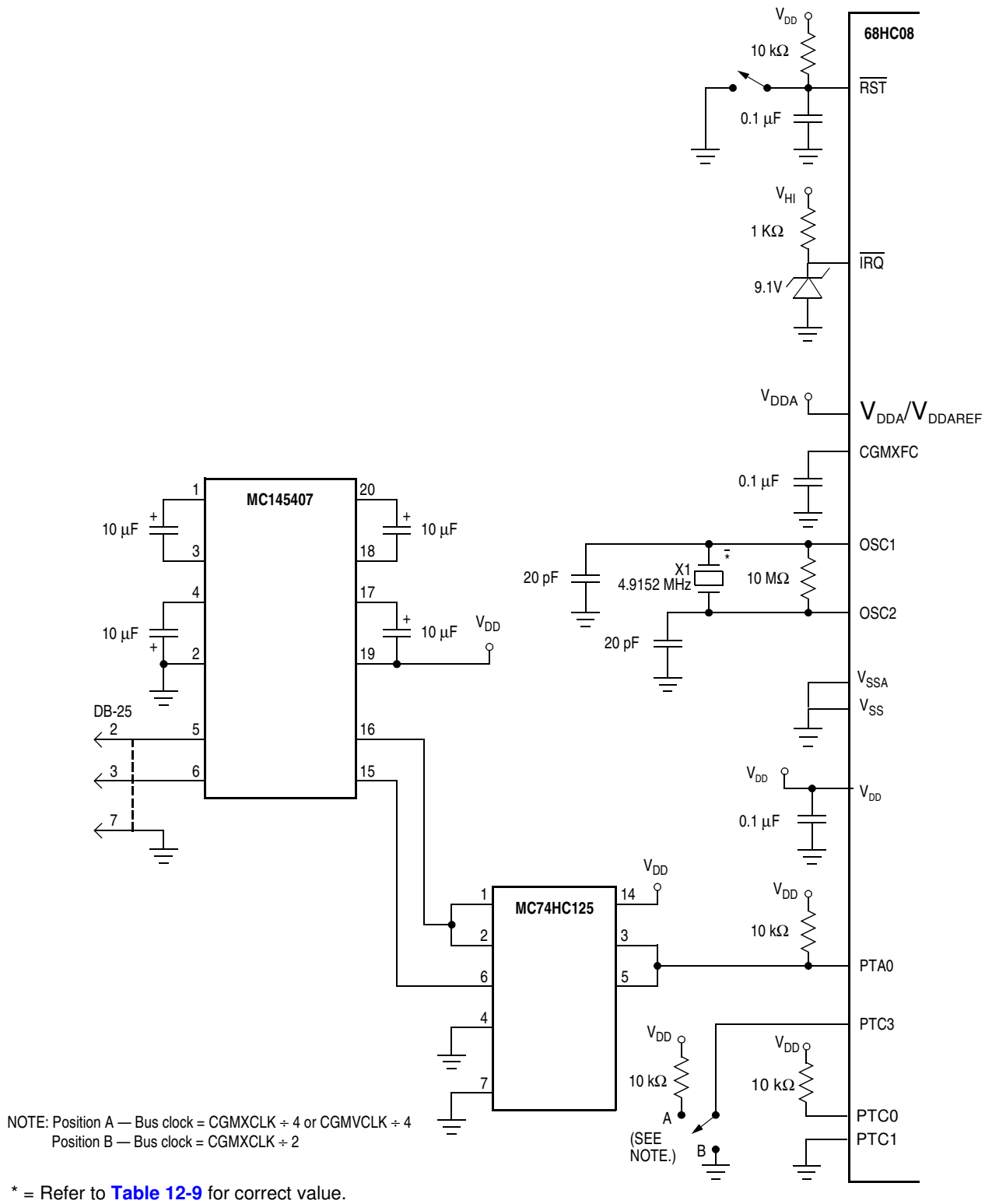

Figure 12-1. Monitor Mode Circuit

12.4.1 Entering Monitor Mode

Table 12-1 shows the pin conditions for entering monitor mode.

Table 12-1. Mode Selection

$\overline{\text{IRQ}}$ Pin	PTC0 Pin	PTC1 Pin	PTA0 Pin	PTC3 Pin	Mode	CGMOUT	Bus Frequency
$V_{\text{HI}}^{(1)}$	1	0	1	1	Monitor	$\frac{\text{CGMXCLK}}{2}$ or $\frac{\text{CGMVCLK}}{2}$	$\frac{\text{CGMOUT}}{2}$
$V_{\text{HI}}^{(1)}$	1	0	1	0	Monitor	CGMXCLK	$\frac{\text{CGMOUT}}{2}$

1. For V_{HI} , [5.0 Volt DC Electrical Characteristics](#) on page 422, and [Maximum Ratings](#) on page 420.

Enter monitor mode by either

- Executing a software interrupt instruction (SWI) or
- Applying a logic 0 and then a logic 1 to the $\overline{\text{RST}}$ pin.

Once out of reset, the MCU waits for the host to send eight security bytes (see [Security](#) on page 173). After the security bytes, the MCU sends a break signal (10 consecutive logic 0s) to the host computer, indicating that it is ready to receive a command.

Monitor mode uses alternate vectors for reset, SWI, and break interrupt. The alternate vectors are in the \$FE page instead of the \$FF page and allow code execution from the internal monitor firmware instead of user code. The COP module is disabled in monitor mode as long as V_{HI} (see [5.0 Volt DC Electrical Characteristics](#) on page 422), is applied to either the $\overline{\text{IRQ}}$ pin or the RESET pin. (See [System Integration Module \(SIM\)](#) on page 101 for more information on modes of operation).

NOTE: *Holding the PTC3 pin low when entering monitor mode causes a bypass of a divide-by-two stage at the oscillator. The CGMOUT frequency is equal to the CGMXCLK frequency, and the OSC1 input directly generates internal bus clocks. In this case, the OSC1 signal must have a 50% duty cycle at maximum bus frequency.*

Table 12-2 is a summary of the differences between user mode and monitor mode.

Table 12-2. Mode Differences

Modes	Functions						
	COP	Reset Vector High	Reset Vector Low	Break Vector High	Break Vector Low	SWI Vector High	SWI Vector Low
User	Enabled	\$FFFE	\$FFFF	\$FFFC	\$FFFD	\$FFFC	\$FFFD
Monitor	Disabled ⁽¹⁾	\$FEFE	\$FEFF	\$FEFC	\$FEFD	\$FEFC	\$FEFD

1. If the high voltage (V_{HI}) is removed from the \overline{IRQ} pin while in monitor mode, the SIM asserts its COP enable output. The COP is a mask option enabled or disabled by the COPD bit in the configuration register. (see [5.0 Volt DC Electrical Characteristics](#) on page 422).

12.4.2 Data Format

Communication with the monitor ROM is in standard non-return-to-zero (NRZ) mark/space data format. (See [Figure 12-2](#) and [Figure 12-3](#).)

The data transmit and receive rate can be anywhere up to 28.8 kBaud. Transmit and receive baud rates must be identical.

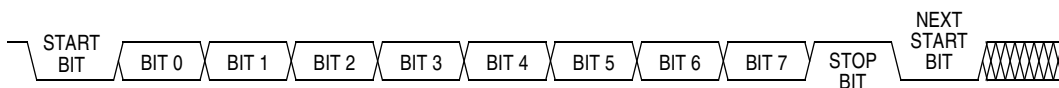

Figure 12-2. Monitor Data Format

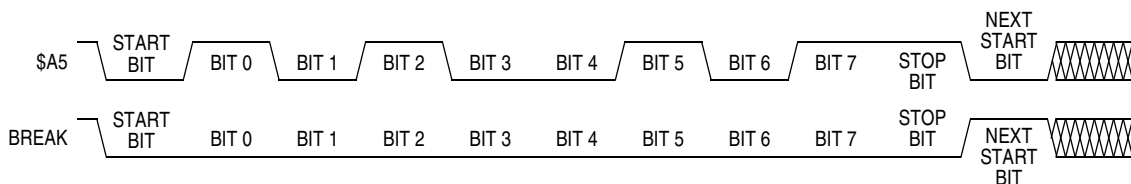

Figure 12-3. Sample Monitor Waveforms

Monitor ROM (MON)

12.4.3 Echoing

As shown in [Figure 12-4](#), the monitor ROM immediately echoes each received byte back to the PTA0 pin for error checking.

Any result of a command appears after the echo of the last byte of the command.

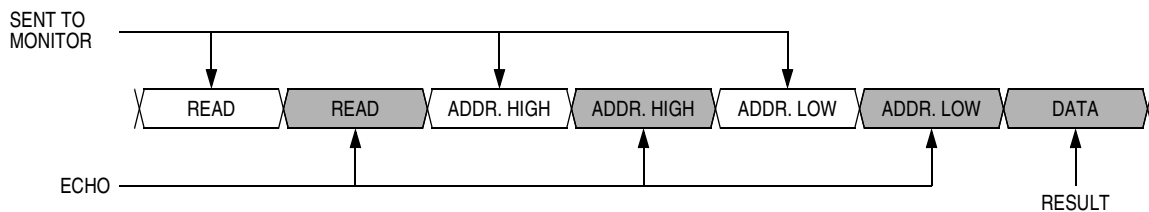

Figure 12-4. Read Transaction

12.4.4 Break Signal

A start bit followed by nine low bits is a break signal. (See [Figure 12-5](#)). When the monitor receives a break signal, it drives the PTA0 pin high for the duration of two bits before echoing the break signal.

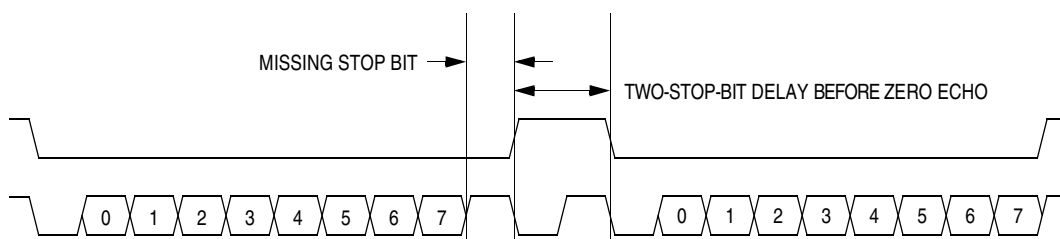

Figure 12-5. Break Transaction

12.4.5 Commands

The monitor ROM uses these commands:

- READ, read memory
- WRITE, write memory
- IREAD, indexed read
- IWRITE, indexed write
- READSP, read stack pointer
- RUN, run user program

A sequence of IREAD or IWRITE commands can access a block of memory sequentially over the full 64-Kbyte memory map.

Table 12-3. READ (Read Memory) Command

Description	Read byte from memory
Operand	Specifies 2-byte address in high byte:low byte order
Data Returned	Returns contents of specified address
Opcode	\$4A
<p>Command Sequence</p>	

Table 12-4. WRITE (Write Memory) Command

Description	Write byte to memory
Operand	Specifies 2-byte address in high byte:low byte order; low byte followed by data byte
Data Returned	None
Opcode	\$49
Command Sequence	

Table 12-5. IREAD (Indexed Read) Command

Description	Read next 2 bytes in memory from last address accessed
Operand	Specifies 2-byte address in high byte:low byte order
Data Returned	Returns contents of next two addresses
Opcode	\$1A
Command Sequence	

Table 12-6. IWRITE (Indexed Write) Command

Description	Write to last address accessed + 1
Operand	Specifies single data byte
Data Returned	None
Opcode	\$19
Command Sequence	

The diagram illustrates the command sequence for the IWRITE command. It consists of four data bytes: IWRITE, IWRITE, DATA, and DATA. The first IWRITE byte is sent to the monitor. The second IWRITE byte is echoed back. The first DATA byte is sent to the monitor, and the second DATA byte is echoed back.

Table 12-7. READSP (Read Stack Pointer) Command

Description	Reads stack pointer
Operand	None
Data Returned	Returns stack pointer in high byte:low byte order
Opcode	\$0C
Command Sequence	

The diagram illustrates the command sequence for the READSP command. It consists of four data bytes: READSP, READSP, SP HIGH, and SP LOW. The first READSP byte is sent to the monitor. The second READSP byte is echoed back. The SP HIGH and SP LOW bytes are echoed back as the result.

Table 12-8. RUN (Run User Program) Command

Description	Executes RTI instruction
Operand	None
Data Returned	None
Opcode	\$28
Command Sequence	

12.4.6 MC68HC908AS60A Baud Rate

With a 4.9152-MHz crystal and the PTC3 pin at logic 1 during reset, data is transferred between the monitor and host at 4800 baud. If the PTC3 pin is at logic 0 during reset, the monitor baud rate is 9600. When the CGM output, CGMOUT, is driven by the PLL, the baud rate is determined by the MUL[7:4] bits in the PLL programming register (PPG). (See [Clock Generator Module \(CGM\)](#) on page 123).

Table 12-9. MC68HC908AS60A Monitor Baud Rate Selection

Monitor Baud Rate	VCO Frequency Multiplier (N)					
	1	2	3	4	5	6
4.9152 MHz	4800	9600	14,400	19,200	24,000	28,800
4.194 MHz	4096	8192	12,288	16,384	20,480	24,576

Care should be taken when setting the baud rate since incorrect baud rate setting can result in communications failure.

12.4.7 Security

A security feature discourages unauthorized reading of FLASH locations while in monitor mode. The host can bypass the security feature at monitor mode entry by sending eight security bytes that match the bytes at locations \$FFF6–\$FFFD. Locations \$FFF6–\$FFFD contain user-defined data.

NOTE: Do not leave locations \$FFF6–\$FFFD blank. For security reasons, program locations \$FFF6–\$FFFD even if they are not used for vectors. If FLASH is unprogrammed, the eight security byte values to be sent are \$FF, the unprogrammed state of FLASH.

During monitor mode entry, the MCU waits after the power-on reset for the host to send the eight security bytes on pin PA0.

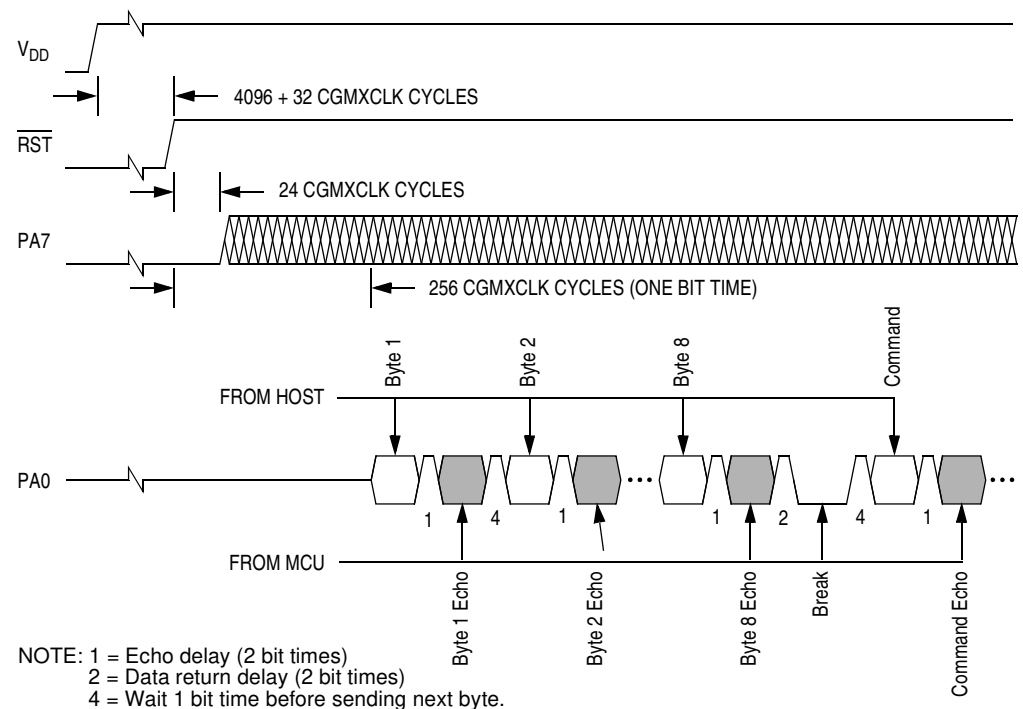

Figure 12-6. Monitor Mode Entry Timing

If the received bytes match those at locations \$FFF6–\$FFFD, the host bypasses the security feature and can read all FLASH locations and execute code from FLASH. Security remains bypassed until a power-on reset occurs. After the host bypasses security, any reset other than a

power-on reset requires the host to send another eight bytes. If the reset was not a power-on reset, the security remains bypassed regardless of the data that the host sends.

If the received bytes do not match the data at locations \$FFF6–\$FFFD, the host fails to bypass the security feature. The MCU remains in monitor mode, but reading FLASH locations returns undefined data, and trying to execute code from FLASH causes an illegal address reset. After the host fails to bypass security, any reset other than a power-on reset causes an endless loop of illegal address resets.

After receiving the eight security bytes from the host, the MCU transmits a break character signalling that it is ready to receive a command.

NOTE: *The MCU does not transmit a break character until after the host sends the eight security bytes.*

Section 13. Computer Operating Properly (COP)

13.1 Contents

13.2	Introduction	175
13.3	Functional Description	176
13.4	I/O Signals	177
13.4.1	CGMXCLK	177
13.4.2	STOP Instruction	177
13.4.3	COPCTL Write	178
13.4.4	Power-On Reset	178
13.4.5	Internal Reset	178
13.4.6	Reset Vector Fetch	178
13.4.7	COPD	178
13.4.8	COPL	178
13.5	COP Control Register	179
13.6	Interrupts	179
13.7	Monitor Mode	179
13.8	Low-Power Modes	179
13.8.1	Wait Mode	179
13.8.2	Stop Mode	180
13.9	COP Module During Break Interrupts	180

13.2 Introduction

The COP module contains a free-running counter that generates a reset if allowed to overflow. The COP module helps software recover from runaway code. Prevent a COP reset by periodically clearing the COP counter.

13.3 Functional Description

The COP counter is a free-running 6-bit counter preceded by a 12-bit prescaler. If not cleared by software, the COP counter overflows and generates an asynchronous reset after $2^{13} - 2^4$ or $2^{18} - 2^4$ CGMXCLK cycles, depending on the state of the COP long timeout bit, COPL, in the CONFIG-1. When COPL = 0, a 4.9152-MHz crystal gives a COP timeout period of 53.3 ms. Writing any value to location \$FFFF before an overflow occurs prevents a COP reset by clearing the COP counter and stages 4–12 of the SIM counter.

NOTE: *Service the COP immediately after reset and before entering or after exiting stop mode to guarantee the maximum time before the first COP counter overflow.*

A COP reset pulls the $\overline{\text{RST}}$ pin low for 32 CGMXCLK cycles and sets the COP bit in the reset status register (RSR).

In monitor mode, the COP is disabled if the $\overline{\text{RST}}$ pin or the $\overline{\text{IRQ}}$ pin is held at V_{Hi} . During the break state, V_{Hi} on the $\overline{\text{RST}}$ pin disables the COP.

NOTE: *Place COP clearing instructions in the main program and not in an interrupt subroutine. Such an interrupt subroutine could keep the COP from generating a reset even while the main program is not working properly.*

13.4 I/O Signals

The following paragraphs describe the signals shown in **Figure 13-1**.

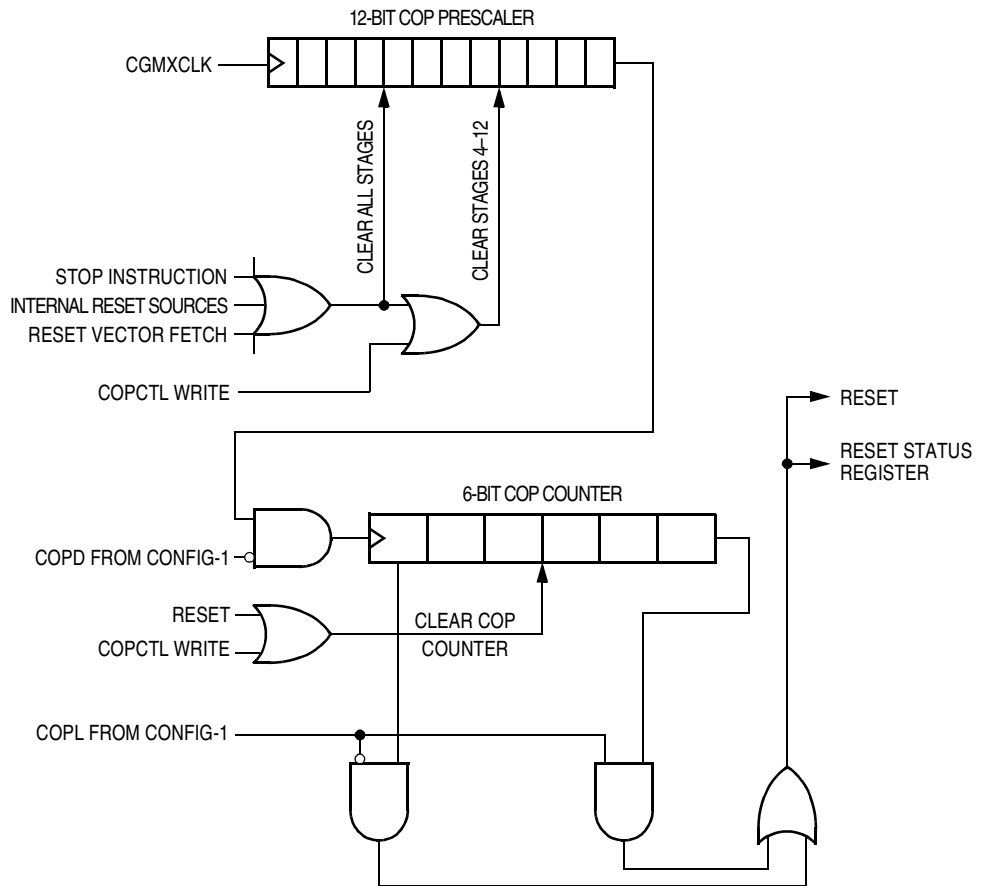

Figure 13-1. COP Block Diagram

13.4.1 CGMXCLK

CGMXCLK is the crystal oscillator output signal. CGMXCLK frequency is equal to the crystal frequency.

13.4.2 STOP Instruction

The STOP instruction clears the COP prescaler.

13.4.3 COPCTL Write

Writing any value to the COP control register (COPCTL) (see [COP Control Register](#) on page 179), clears the COP counter and clears stages 12 through 4 of the COP prescaler. Reading the COP control register returns the reset vector.

13.4.4 Power-On Reset

The power-on reset (POR) circuit clears the COP prescaler 4096 CGMXCLK cycles after power-up.

13.4.5 Internal Reset

An internal reset clears the COP prescaler and the COP counter.

13.4.6 Reset Vector Fetch

A reset vector fetch occurs when the vector address appears on the data bus. A reset vector fetch clears the COP prescaler.

13.4.7 COPD

The COPD signal reflects the state of the COP disable bit (COPD) in the configuration register. (See [Configuration Register \(CONFIG-1\)](#) on page 151).

13.4.8 COPL

The COPL signal reflects the state of the COP rate select bit. (COPL) in the configuration register. (See [Configuration Register \(CONFIG-1\)](#) on page 151).

13.5 COP Control Register

The COP control register is located at address \$FFFF and overlaps the reset vector. Writing any value to \$FFFF clears the COP counter and starts a new timeout period. Reading location \$FFFF returns the low byte of the reset vector.

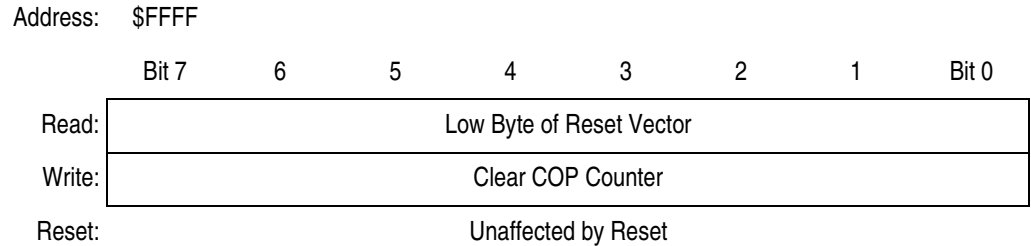

Figure 13-2. COP Control Register (COPCTL)

13.6 Interrupts

The COP does not generate CPU interrupt requests.

13.7 Monitor Mode

The COP is disabled in monitor mode when V_{Hi} is present on the \overline{IRQ} pin or on the \overline{RST} pin.

13.8 Low-Power Modes

The WAIT and STOP instructions put the MCU in low power-consumption standby modes.

13.8.1 Wait Mode

The COP remains active in wait mode. To prevent a COP reset during wait mode, periodically clear the COP counter in a CPU interrupt routine.

13.8.2 Stop Mode

Stop mode turns off the CGMXCLK input to the COP and clears the COP prescaler. Service the COP immediately before entering or after exiting stop mode to ensure a full COP timeout period after entering or exiting stop mode.

The STOP bit in the configuration register (CONFIG) enables the STOP instruction. To prevent inadvertently turning off the COP with a STOP instruction, disable the STOP instruction by clearing the STOP bit.

13.9 COP Module During Break Interrupts

The COP is disabled during a break interrupt when V_{Hi} is present on the \overline{RST} pin.

Section 14. Low Voltage Inhibit (LVI)

14.1 Contents

14.2	Introduction	181
14.3	Features	181
14.4	Functional Description	182
14.4.1	Polled LVI Operation	183
14.4.2	Forced Reset Operation	184
14.4.3	False Reset Protection	184
14.5	LVI Status Register	184
14.6	LVI Interrupts	184
14.7	Low-Power Modes	185
14.7.1	Wait Mode	185
14.7.2	Stop Mode	186

14.2 Introduction

This section describes the (TSMC .5u) low-voltage inhibit module (lvim26or43_tsmc_b10), which monitors the voltage on the V_{DD} pin and can force a reset when the V_{DD} voltage falls to the LVI trip voltage.

14.3 Features

Features of the LVI module include:

- Programmable LVI Reset
- Programmable Power Consumption

NOTE: *If a low voltage interrupt (LVI) occurs during programming of EEPROM or Flash memory, then adequate programming time may not have been allowed to ensure the integrity and retention of the data. It is the responsibility of the user to ensure that in the event of an LVI any addresses being programmed receive specification programming conditions.*

14.4 Functional Description

Figure 14-1 shows the structure of the LVI module. The LVI is enabled out of reset. The LVI module contains a bandgap reference circuit and comparator. The LVI power bit, LVIPWR, enables the LVI to monitor V_{DD} voltage. The LVI reset bit, LVIRST, enables the LVI module to generate a reset when V_{DD} falls below a voltage, LVI_{TRIPF} , and remains at or below that level for nine or more consecutive CPU cycles.

Note that short V_{DD} spikes may not trip the LVI. It is the user's responsibility to ensure a clean V_{DD} signal within the specified operating voltage range if normal microcontroller operation is to be guaranteed.

LVISTOP, enables the LVI module during stop mode. This will ensure when the STOP instruction is implemented, the LVI will continue to monitor the voltage level on V_{DD} . LVIPWR, LVISTOP, and LVIRST are in the configuration register, CONFIG-1 (see **Configuration Register (CONFIG-1)** on page 151).

Once an LVI reset occurs, the MCU remains in reset until V_{DD} rises above a voltage, LVI_{TRIPR} . V_{DD} must be above LVI_{TRIPR} for only one CPU cycle to bring the MCU out of reset (see **Forced Reset Operation** on page 184). The output of the comparator controls the state of the LVIOUT flag in the LVI status register (LVISR).

An LVI reset also drives the $\overline{\text{RST}}$ pin low to provide low-voltage protection to external peripheral devices.

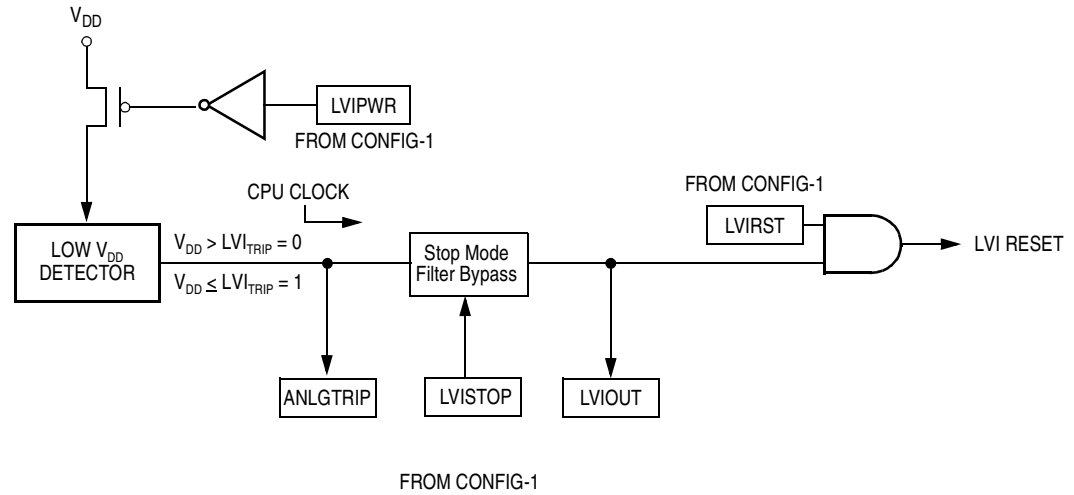

Figure 14-1. LVI Module Block Diagram

Figure 14-2. LVI I/O Register Summary

Addr.	Register Name	Bit 7	6	5	4	3	2	1	Bit 0
\$FE0F	LVI Status Register (LVISR)	LVIOUT							

= Unimplemented

14.4.1 Polled LVI Operation

In applications that can operate at V_{DD} levels below the LVI_{TRIPF} level, software can monitor V_{DD} by polling the LVIOUT bit. In the configuration register, the LVIPWR bit must be at logic 1 to enable the LVI module, and the LVIRST bit must be at logic 0 to disable LVI resets.

Low Voltage Inhibit (LVI)

14.4.2 Forced Reset Operation

In applications that require V_{DD} to remain above the LVI_{TRIPF} level, enabling LVI resets allows the LVI module to reset the MCU when V_{DD} falls to the LVI_{TRIPF} level and remains at or below that level for nine or more consecutive CPU cycles. In the configuration register, the LVIPWR and LVIRST bits must be at logic 1 to enable the LVI module and to enable LVI resets.

14.4.3 False Reset Protection

In order for the LVI module to reset the MCU, V_{DD} must remain at or below the LVI_{TRIPF} level for nine or more consecutive CPU cycles. V_{DD} must be above LVI_{TRIPR} for only one CPU cycle to bring the MCU out of reset.

14.5 LVI Status Register

The LVI status register flags V_{DD} voltages below the LVI_{TRIPF} level.

Address: \$FE0F

	Bit 7	6	5	4	3	2	1	Bit 0
Read:	LVIOUT	0	0	0	0	0	0	0
Write:								
Reset:	0	0	0	0	0	0	0	0

 = Unimplemented

Figure 14-3. LVI Status Register (LVISR)

LVIOUT — LVI Output Bit

This read-only flag becomes set when the V_{DD} voltage falls below the V_{LVI_TRIPF} voltage for 32 to 40 CGMXCLK cycles. (See [Table 14-1](#)). Reset clears the LVIOUT bit.

Table 14-1. LVIOUT Bit Indication

V_{DD}		LVIOUT
At Level:	For Number of CGMXCLK Cycles:	
$V_{DD} > V_{LVI_TRIPR}$	Any	0
$V_{DD} < V_{LVI_TRIPF}$	< 32 CGMXCLK Cycles	0
$V_{DD} < V_{LVI_TRIPF}$	Between 32 and 40 CGMXCLK Cycles	0 or 1
$V_{DD} < V_{LVI_TRIPF}$	> 40 CGMXCLK Cycles	1
$V_{LVI_TRIPF} < V_{DD} < V_{LVI_TRIPR}$	Any	Previous Value

14.6 LVI Interrupts

The LVI module does not generate interrupt requests.

14.7 Low-Power Modes

The WAIT and STOP instructions put the MCU in low power-consumption standby modes.

14.7.1 Wait Mode

With the LVIPWR bit in the configuration register programmed to logic 1, the LVI module is active after a WAIT instruction.

With the LVIRST bit in the configuration register programmed to logic 1, the LVI module can generate a reset and bring the MCU out of wait mode.

14.7.2 Stop Mode

With the LVISTOP and LVIPWR bits in the configuration register programmed to a logic 1, the LVI module will be active after a STOP instruction. Because CPU clocks are disabled during stop mode, the LVI trip will generate a reset and bring the MCU out of stop.

With the LVIPWR bit in the configuration register programmed to logic 1 and the LVISTOP bit at a logic 0, the LVI module will be inactive after a STOP instruction.

Note that the LVI feature is intended to provide the safe shutdown of the microcontroller and thus protection of related circuitry prior to any application V_{DD} voltage collapsing completely to an unsafe level. It is not intended that users operate the microcontroller at lower than specified operating voltage V_{DD} .

Section 15. External Interrupt Module (IRQ)

15.1 Contents

15.2 Introduction	187
15.3 Features	187
15.4 Functional Description	188
15.5 IRQ Pin	191
15.6 IRQ Module During Break Interrupts	192
15.7 IRQ Status and Control Register	192

15.2 Introduction

This section describes the nonmaskable external interrupt (IRQ) input.

15.3 Features

Features include:

- Dedicated External Interrupt Pin ($\overline{\text{IRQ}}$)
- Hysteresis Buffer
- Programmable Edge-Only or Edge- and Level-Interrupt Sensitivity
- Automatic Interrupt Acknowledge

15.4 Functional Description

A logic 0 applied to the external interrupt pin can latch a CPU interrupt request. **Figure 15-1** shows the structure of the IRQ module.

Interrupt signals on the $\overline{\text{IRQ}}$ pin are latched into the IRQ latch. An interrupt latch remains set until one of the following actions occurs:

- Vector fetch — A vector fetch automatically generates an interrupt acknowledge signal that clears the latch that caused the vector fetch.
- Software clear — Software can clear an interrupt latch by writing to the appropriate acknowledge bit in the interrupt status and control register (ISCR). Writing a logic 1 to the ACK bit clears the IRQ latch.
- Reset — A reset automatically clears both interrupt latches.

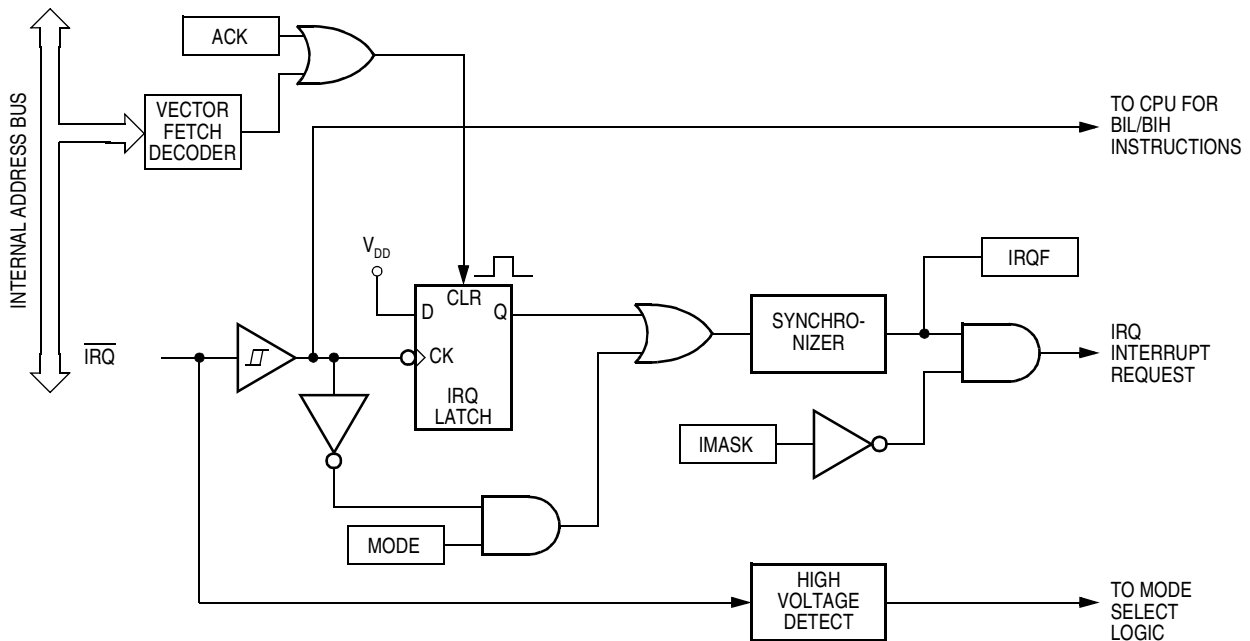

Figure 15-1. IRQ Block Diagram

Table 15-1. IRQ I/O Register Summary

Addr.	Register Name		Bit 7	6	5	4	3	2	1	Bit 0
\$001A	IRQ Status/Control Register (ISCR)	Read:	0	0	0	0	IRQF	0	IMASK	MODE
		Write:	R	R	R	R	R	ACK		

R

 = Reserved

The external interrupt pin is falling-edge triggered and is software-configurable to be both falling-edge and low-level triggered. The MODE bit in the ISCR controls the triggering sensitivity of the $\overline{\text{IRQ}}$ pin.

When an interrupt pin is edge-triggered only, the interrupt latch remains set until a vector fetch, software clear, or reset occurs.

When an interrupt pin is both falling-edge and low-level-triggered, the interrupt latch remains set until both of the following occur:

- Vector fetch or software clear
- Return of the interrupt pin to logic 1

The vector fetch or software clear may occur before or after the interrupt pin returns to logic 1. As long as the pin is low, the interrupt request remains pending. A reset will clear the latch and the MODE1 control bit, thereby clearing the interrupt even if the pin stays low.

When set, the IMASK bit in the ISCR masks all external interrupt requests. A latched interrupt request is not presented to the interrupt priority logic unless the corresponding IMASK bit is clear.

NOTE: *The interrupt mask (I) in the condition code register (CCR) masks all interrupt requests, including external interrupt requests. (See [Figure 15-2](#)).*

External Interrupt Module (IRQ)

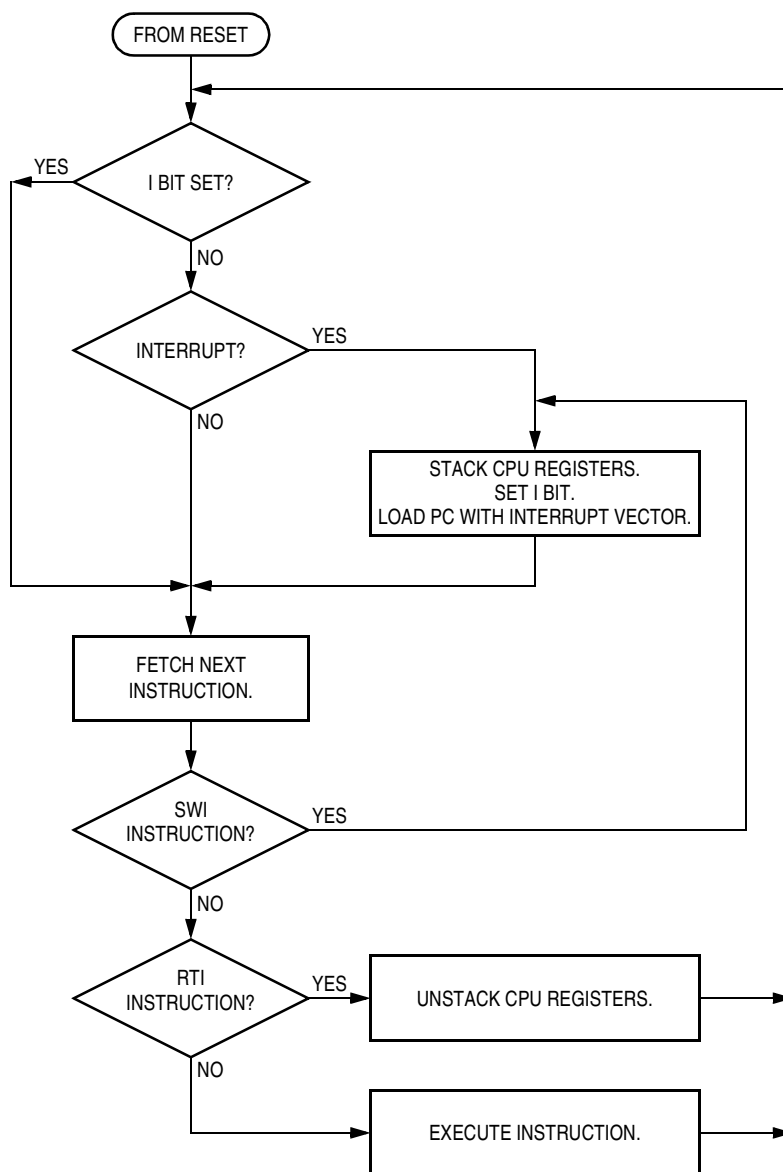

Figure 15-2. IRQ Interrupt Flowchart

15.5 $\overline{\text{IRQ}}$ Pin

A logic 0 on the $\overline{\text{IRQ}}$ pin can latch an interrupt request into the IRQ latch. A vector fetch, software clear, or reset clears the IRQ latch.

If the MODE bit is set, the $\overline{\text{IRQ}}$ pin is both falling-edge sensitive and low-level sensitive. With MODE set, both of the following actions must occur to clear the IRQ latch:

- Vector fetch or software clear — A vector fetch generates an interrupt acknowledge signal to clear the latch. Software may generate the interrupt acknowledge signal by writing a logic 1 to the ACK bit in the interrupt status and control register (ISCR). The ACK bit is useful in applications that poll the $\overline{\text{IRQ}}$ pin and require software to clear the IRQ latch. Writing to the ACK bit can also prevent spurious interrupts due to noise. Setting ACK does not affect subsequent transitions on the $\overline{\text{IRQ}}$ pin. A falling edge on $\overline{\text{IRQ}}$ that occurs after writing to the ACK bit latches another interrupt request. If the IRQ mask bit, IMASK, is clear, the CPU loads the program counter with the vector address at locations \$FFFA and \$FFFB.
- Return of the $\overline{\text{IRQ}}$ pin to logic 1 — As long as the $\overline{\text{IRQ}}$ pin is at logic 0, the IRQ1 latch remains set.

The vector fetch or software clear and the return of the $\overline{\text{IRQ}}$ pin to logic 1 can occur in any order. The interrupt request remains pending as long as the $\overline{\text{IRQ}}$ pin is at logic 0. A reset will clear the latch and the MODE control bit, thereby clearing the interrupt even if the pin stays low.

If the MODE bit is clear, the $\overline{\text{IRQ}}$ pin is falling-edge sensitive only. With MODE clear, a vector fetch or software clear immediately clears the IRQ latch.

The IRQF bit in the ISCR register can be used to check for pending interrupts. The IRQF bit is not affected by the IMASK bit, which makes it useful in applications where polling is preferred.

Use the BIH or BIL instruction to read the logic level on the $\overline{\text{IRQ}}$ pin.

NOTE: *When using the level-sensitive interrupt trigger, avoid false interrupts by masking interrupt requests in the interrupt routine.*

15.6 IRQ Module During Break Interrupts

The system integration module (SIM) controls whether the IRQ interrupt latch can be cleared during the break state. The BCFE bit in the SIM break flag control register (SBFCR) enables software to clear the latches during the break state. (See [SIM Break Flag Control Register](#) on page 122)

To allow software to clear the IRQ latch during a break interrupt, write a logic 1 to the BCFE bit. If a latch is cleared during the break state, it remains cleared when the MCU exits the break state.

To protect the latch during the break state, write a logic 0 to the BCFE bit. With BCFE at logic 0 (its default state), writing to the ACK bit in the IRQ status and control register during the break state has no effect on the IRQ latch.

15.7 IRQ Status and Control Register

The IRQ status and control register (ISCR) controls and monitors operation of the IRQ module. The ISCR has these functions:

- Shows the state of the IRQ interrupt flag
- Clears the IRQ interrupt latch
- Masks IRQ interrupt request
- Controls triggering sensitivity of the $\overline{\text{IRQ}}$ interrupt pin

Address: \$001A

	Bit 7	6	5	4	3	2	1	Bit 0
Read:	0	0	0	0	IRQF	0	IMASK	MODE
Write:	R	R	R	R	R	ACK		
Reset:	0	0	0	0	0	0	0	0

R = Reserved

Figure 15-3. IRQ Status and Control Register (ISCR)

IRQF — IRQ Flag Bit

This read-only status bit is high when the IRQ interrupt is pending.

1 = $\overline{\text{IRQ}}$ interrupt pending

0 = $\overline{\text{IRQ}}$ interrupt not pending

ACK — IRQ Interrupt Request Acknowledge Bit

Writing a logic 1 to this write-only bit clears the IRQ latch. ACK always reads as logic 0. Reset clears ACK.

IMASK — IRQ Interrupt Mask Bit

Writing a logic 1 to this read/write bit disables IRQ interrupt requests. Reset clears IMASK.

1 = IRQ interrupt requests disabled

0 = IRQ interrupt requests enabled

MODE — IRQ Edge/Level Select Bit

This read/write bit controls the triggering sensitivity of the $\overline{\text{IRQ}}$ pin. Reset clears MODE.

1 = $\overline{\text{IRQ}}$ interrupt requests on falling edges and low levels

0 = $\overline{\text{IRQ}}$ interrupt requests on falling edges only

Section 16. Serial Communications Interface (SCI)

16.1 Contents

16.2	Introduction	196
16.3	Features	196
16.4	Pin Name Conventions	197
16.5	Functional Description	197
16.5.1	Data Format	200
16.5.2	Transmitter	200
16.5.2.1	Character Length	200
16.5.2.2	Character Transmission	200
16.5.2.3	Break Characters	204
16.5.2.4	Idle Characters	204
16.5.2.5	Inversion of Transmitted Output	205
16.5.2.6	Transmitter Interrupts	205
16.5.3	Receiver	206
16.5.3.1	Character Length	208
16.5.3.2	Character Reception	208
16.5.3.3	Data Sampling	208
16.5.3.4	Framing Errors	211
16.5.3.5	Baud Rate Tolerance	211
16.5.3.6	Receiver Wakeup	213
16.5.3.7	Receiver Interrupts	214
16.5.3.8	Error Interrupts	214
16.6	Low-Power Modes	215
16.6.1	Wait Mode	215
16.6.2	Stop Mode	215
16.7	SCI During Break Module Interrupts	216
16.8	I/O Signals	216
16.8.1	PTE0/SCTxD (Transmit Data)	217
16.8.2	PTE1/SCRxD (Receive Data)	217

16.9	I/O Registers	217
16.9.1	SCI Control Register 1	217
16.9.2	SCI Control Register 2	220
16.9.3	SCI Control Register 3	224
16.9.4	SCI Status Register 1	226
16.9.5	SCI Status Register 2	230
16.9.6	SCI Data Register	231
16.9.7	SCI Baud Rate Register	231

16.2 Introduction

The SCI allows asynchronous communications with peripheral devices and other MCUs.

16.3 Features

The SCI module's features include:

- Full Duplex Operation
- Standard Mark/Space Non-Return-to-Zero (NRZ) Format
- 32 Programmable Baud Rates
- Programmable 8-Bit or 9-Bit Character Length
- Separately Enabled Transmitter and Receiver
- Separate Receiver and Transmitter CPU Interrupt Requests
- Programmable Transmitter Output Polarity
- Two Receiver Wakeup Methods:
 - Idle Line Wakeup
 - Address Mark Wakeup
- Interrupt-Driven Operation with Eight Interrupt Flags:
 - Transmitter Empty
 - Transmission Complete
 - Receiver Full

- Idle Receiver Input
- Receiver Overrun
- Noise Error
- Framing Error
- Parity Error
- Receiver Framing Error Detection
- Hardware Parity Checking
- 1/16 Bit-Time Noise Detection

16.4 Pin Name Conventions

The generic names of the SCI input/output (I/O) pins are:

- RxD (receive data)
- TxD (transmit data)

SCI I/O lines are implemented by sharing parallel I/O port pins. The full name of an SCI input or output reflects the name of the shared port pin. **Table 16-1** shows the full names and the generic names of the SCI I/O pins. The generic pin names appear in the text of this section.

Table 16-1. Pin Name Conventions

Generic Pin Names	RxD	TxD
Full Pin Names	PTE1/SCRxD	PTE0/SCTxD

16.5 Functional Description

Figure 16-1 shows the structure of the SCI module. The SCI allows full-duplex, asynchronous, NRZ serial communication between the MCU and remote devices, including other MCUs. The transmitter and receiver of the SCI operate independently, although they use the same baud rate generator. During normal operation, the CPU monitors the status of the SCI, writes the data to be transmitted, and processes received data.

Serial Communications Interface (SCI)

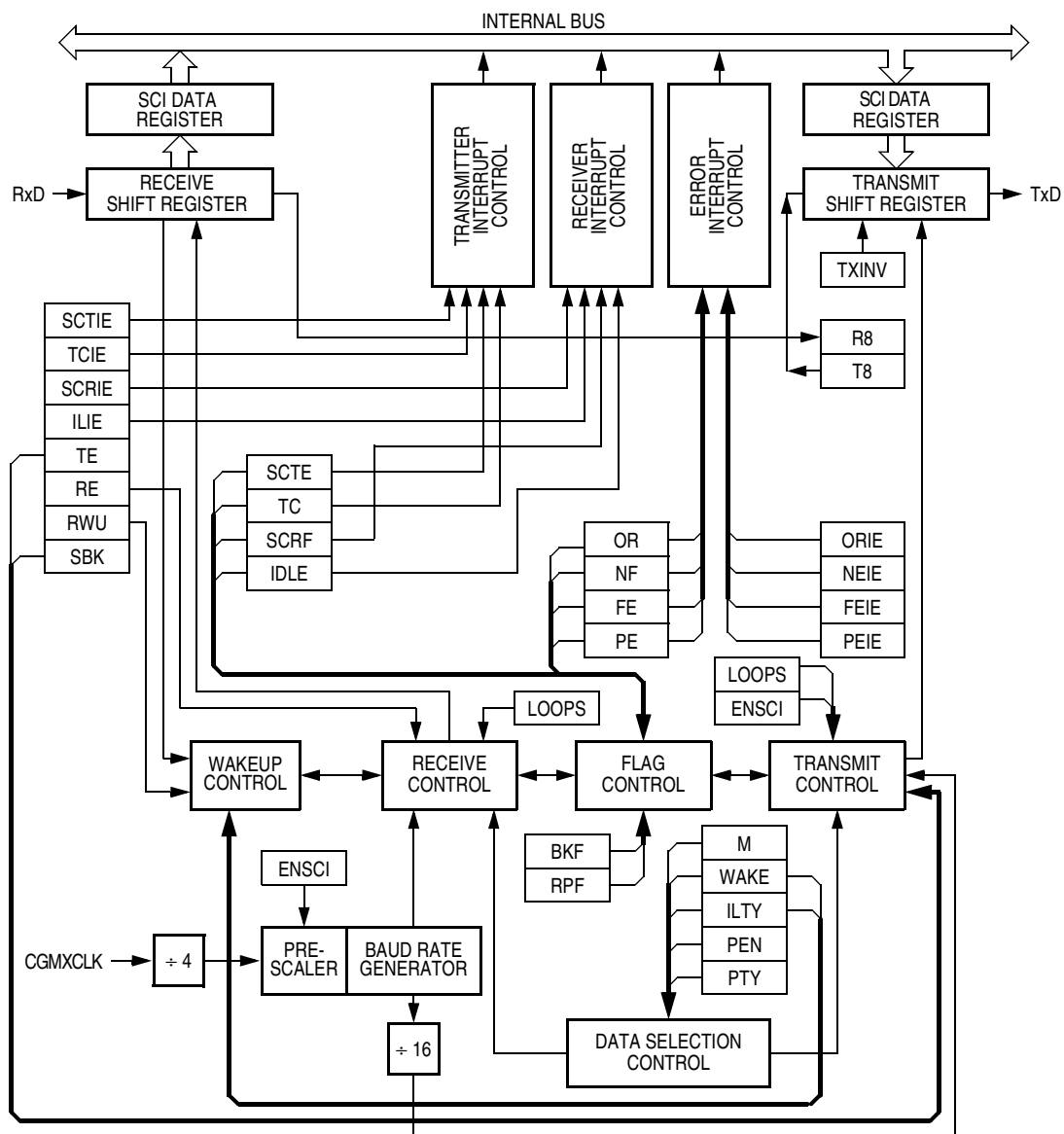

Figure 16-1. SCI Module Block Diagram

Register Name	Bit 7	6	5	4	3	2	1	Bit 0	
SCI Control Register 1 (SCC1)	Read:	LOOPS	ENSCI	TXINV	M	WAKE	ILTY	PEN	PTY
	Write:								
	Reset:	0	0	0	0	0	0	0	0
SCI Control Register 2 (SCC2)	Read:	SCTIE	TCIE	SCRIE	ILIE	TE	RE	RWU	SBK
	Write:								
	Reset:	0	0	0	0	0	0	0	0
SCI Control Register 3 (SCC3)	Read:	R8	T8	R	R	ORIE	NEIE	FEIE	PEIE
	Write:								
	Reset:	U	U	0	0	0	0	0	0
SCI Status Register 1 (SCS1)	Read:	SCTE	TC	SCRF	IDLE	OR	NF	FE	PE
	Write:								
	Reset:	1	1	0	0	0	0	0	0
SCI Status Register 2 (SCS2)	Read:	0	0	0	0	0	0	BKF	RPF
	Write:								
	Reset:	0	0	0	0	0	0	0	0
SCI Data Register (SCDR)	Read:	R7	R6	R5	R4	R3	R2	R1	R0
	Write:	T7	T6	T5	T4	T3	T2	T1	T0
	Reset:	Unaffected by Reset							
SCI Baud Rate Register (SCBR)	Read:	0	0	SCP1	SCP0	R	SCR2	SCR1	SCR0
	Write:								
	Reset:	0	0	0	0	0	0	0	0

= Unimplemented U = Unaffected R = Reserved

Figure 16-2. SCI I/O Register Summary

Table 16-2. SCI I/O Register Address Summary

Register	SCC1	SCC2	SCC3	SCS1	SCS2	SCDR	SCBR
Address	\$0013	\$0014	\$0015	\$0016	\$0017	\$0018	\$0019

16.5.1 Data Format

The SCI uses the standard non-return-to-zero mark/space data format illustrated in [Figure 16-3](#).

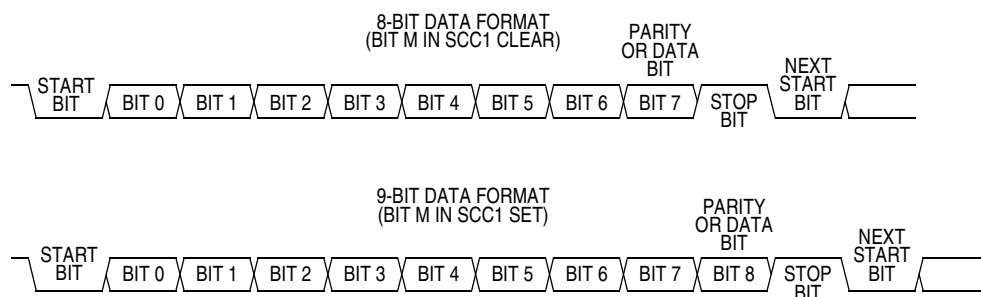

Figure 16-3. SCI Data Formats

16.5.2 Transmitter

[Figure 16-4](#) shows the structure of the SCI transmitter.

16.5.2.1 Character Length

The transmitter can accommodate either 8-bit or 9-bit data. The state of the M bit in SCI control register 1 (SCC1) determines character length. When transmitting 9-bit data, bit T8 in SCI control register 3 (SCC3) is the ninth bit (bit 8).

16.5.2.2 Character Transmission

During an SCI transmission, the transmit shift register shifts a character out to the TxD pin. The SCI data register (SCDR) is the write-only buffer between the internal data bus and the transmit shift register. To initiate an SCI transmission:

1. Enable the SCI by writing a logic 1 to the enable SCI bit (ENSCI) in SCI control register 1 (SCC1).
2. Enable the transmitter by writing a logic 1 to the transmitter enable bit (TE) in SCI control register 2 (SCC2).
3. Clear the SCI transmitter empty bit (SCTE) by first reading SCI

status register 1 (SCS1) and then writing to the SCDR.

4. Repeat step 3 for each subsequent transmission.

At the start of a transmission, transmitter control logic automatically loads the transmit shift register with a preamble of logic 1s. After the preamble shifts out, control logic transfers the SCDR data into the transmit shift register. A logic 0 start bit automatically goes into the least significant bit position of the transmit shift register. A logic 1 stop bit goes into the most significant bit position.

The SCI transmitter empty bit, SCTE, in SCS1 becomes set when the SCDR transfers a byte to the transmit shift register. The SCTE bit indicates that the SCDR can accept new data from the internal data bus. If the SCI transmit interrupt enable bit, SCTIE, in SCC2 is also set, the SCTE bit generates a transmitter CPU interrupt request.

When the transmit shift register is not transmitting a character, the TxD pin goes to the idle condition, logic 1. If at any time software clears the ENSCI bit in SCI control register 1 (SCC1), the transmitter and receiver relinquish control of the port E pins.

Serial Communications Interface (SCI)

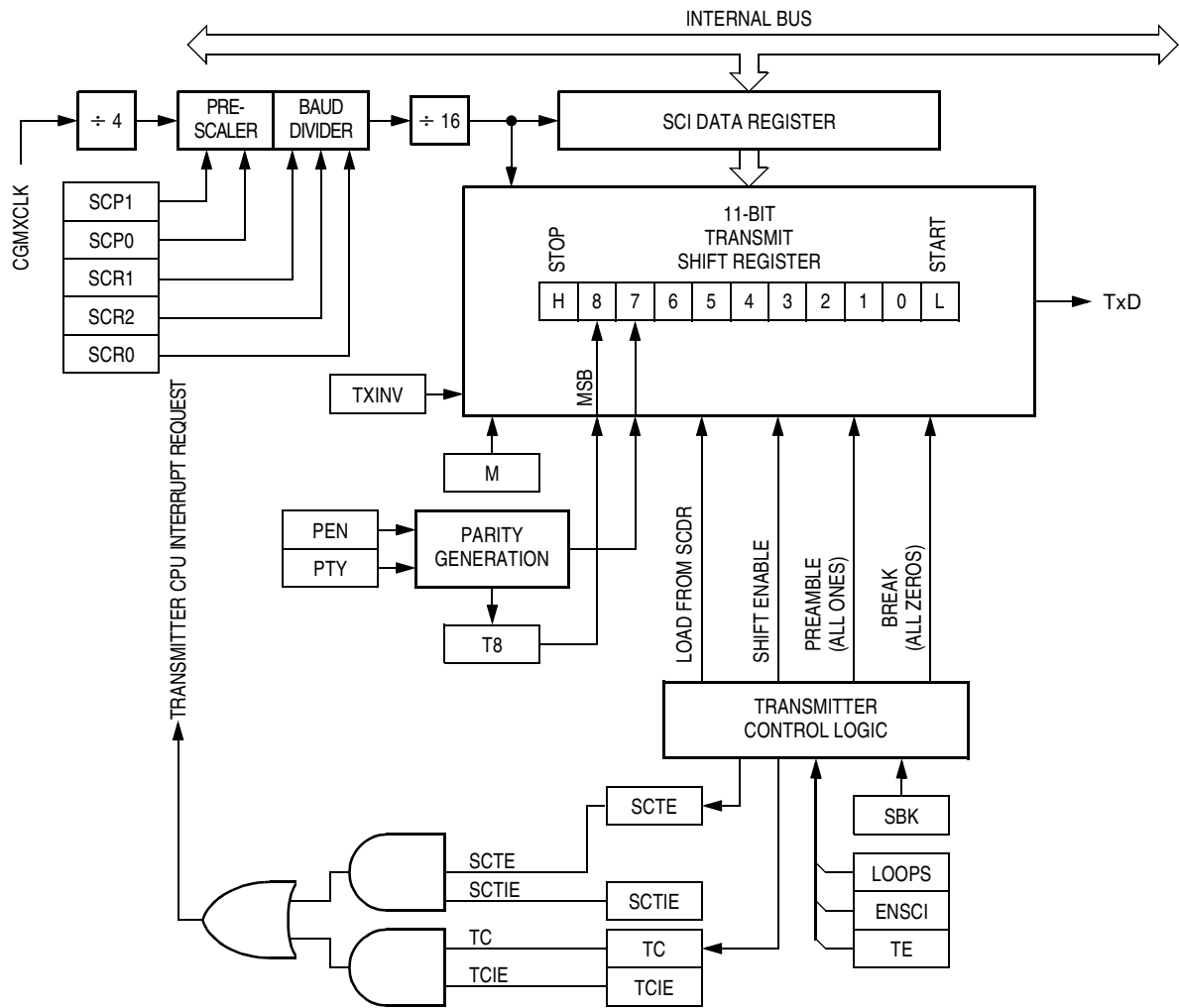

Figure 16-4. SCI Transmitter

Register Name	Bit 7	6	5	4	3	2	1	Bit 0	
SCI Control Register 1 (SCC1)	Read:	LOOPS	ENSCI	TXINV	M	WAKE	ILTY	PEN	PTY
	Write:								
	Reset:	0	0	0	0	0	0	0	0
SCI Control Register 2 (SCC2)	Read:	SCTIE	TCIE	SCRIE	ILIE	TE	RE	RWU	SBK
	Write:								
	Reset:	0	0	0	0	0	0	0	0
SCI Control Register 3 (SCC3)	Read:	R8	T8	R	R	ORIE	NEIE	FEIE	PEIE
	Write:								
	Reset:	U	U	0	0	0	0	0	0
SCI Status Register 1 (SCS1)	Read:	SCTE	TC	SCRF	IDLE	OR	NF	FE	PE
	Write:								
	Reset:	1	1	0	0	0	0	0	0
SCI Data Register (SCDR)	Read:	R7	R6	R5	R4	R3	R2	R1	R0
	Write:	T7	T6	T5	T4	T3	T2	T1	T0
	Reset:	Unaffected by Reset							
SCI Baud Rate Register (SCBR)	Read:	0	0	SCP1	SCP0	R	SCR2	SCR1	SCR0
	Write:								
	Reset:	0	0	0	0	0	0	0	0

= Unimplemented U = Unaffected R = Reserved

Figure 16-5. SCI Transmitter I/O Register Summary

Table 16-3. SCI Transmitter I/O Address Summary

Register	SCC1	SCC2	SCC3	SCS1	SCDR	SCBR
Address	\$0013	\$0014	\$0015	\$0016	\$0018	\$0019

16.5.2.3 Break Characters

Writing a logic 1 to the send break bit, SBK, in SCC2 loads the transmit shift register with a break character. A break character contains all logic 0s and has no start, stop, or parity bit. Break character length depends on the M bit in SCC1. As long as SBK is at logic 1, transmitter logic continuously loads break characters into the transmit shift register. After software clears the SBK bit, the shift register finishes transmitting the last break character and then transmits at least one logic 1. The automatic logic 1 at the end of a break character guarantees the recognition of the start bit of the next character.

The SCI recognizes a break character when a start bit is followed by eight or nine logic 0 data bits and a logic 0 where the stop bit should be. Receiving a break character has the following effects on SCI registers:

- Sets the framing error bit (FE) in SCS1
- Sets the SCI receiver full bit (SCRF) in SCS1
- Clears the SCI data register (SCDR)
- Clears the R8 bit in SCC3
- Sets the break flag bit (BKF) in SCS2
- May set the overrun (OR), noise flag (NF), parity error (PE), or reception in progress flag (RPF) bits

16.5.2.4 Idle Characters

An idle character contains all logic 1s and has no start, stop, or parity bit. Idle character length depends on the M bit in SCC1. The preamble is a synchronizing idle character that begins every transmission.

If the TE bit is cleared during a transmission, the TxD pin becomes idle after completion of the transmission in progress. Clearing and then setting the TE bit during a transmission queues an idle character to be sent after the character currently being transmitted.

NOTE: *When a break sequence is followed immediately by an idle character, this SCI design exhibits a condition in which the break character length is reduced by one half bit time. In this instance, the break sequence will*

consist of a valid start bit, eight or nine data bits (as defined by the M bit in SCC1) of logic 0 and one half data bit length of logic 0 in the stop bit position followed immediately by the idle character. To ensure a break character of the proper length is transmitted, always queue up a byte of data to be transmitted while the final break sequence is in progress.

NOTE: *When queueing an idle character, return the TE bit to logic 1 before the stop bit of the current character shifts out to the TxD pin. Setting TE after the stop bit appears on TxD causes data previously written to the SCDR to be lost.*

A good time to toggle the TE bit for a queued idle character is when the SCTE bit becomes set and just before writing the next byte to the SCDR.

16.5.2.5 Inversion of Transmitted Output

The transmit inversion bit (TXINV) in SCI control register 1 (SCC1) reverses the polarity of transmitted data. All transmitted values, including idle, break, start, and stop bits, are inverted when TXINV is at logic 1. (See **SCI Control Register 1**.)

16.5.2.6 Transmitter Interrupts

The following conditions can generate CPU interrupt requests from the SCI transmitter:

- SCI transmitter empty (SCTE) — The SCTE bit in SCS1 indicates that the SCDR has transferred a character to the transmit shift register. SCTE can generate a transmitter CPU interrupt request. Setting the SCI transmit interrupt enable bit, SCTIE, in SCC2 enables the SCTE bit to generate transmitter CPU interrupt requests.
- Transmission complete (TC) — The TC bit in SCS1 indicates that the transmit shift register and the SCDR are empty and that no break or idle character has been generated. The transmission complete interrupt enable bit, TCIE, in SCC2 enables the TC bit to generate transmitter CPU interrupt requests.

Serial Communications Interface (SCI)

16.5.3 Receiver

Figure 16-6 shows the structure of the SCI receiver.

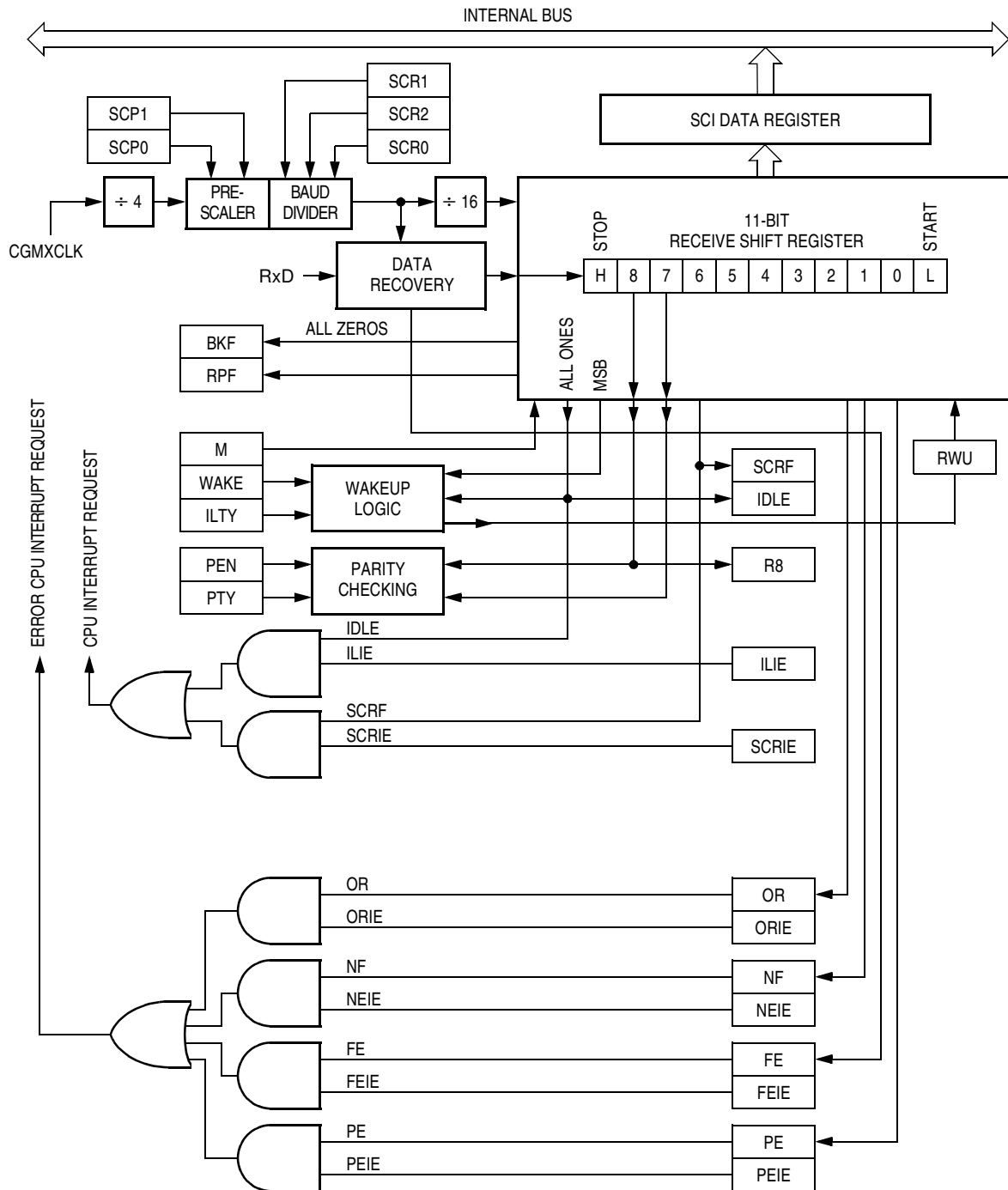

Figure 16-6. SCI Receiver Block Diagram

Register Name	Bit 7	6	5	4	3	2	1	Bit 0	
SCI Control Register 1 (SCC1)	Read:	LOOPS	ENSCI	TXINV	M	WAKE	ILTY	PEN	PTY
	Write:								
	Reset:	0	0	0	0	0	0	0	0
SCI Control Register 2 (SCC2)	Read:	SCTIE	TCIE	SCRIE	ILIE	TE	RE	RWU	SBK
	Write:								
	Reset:	0	0	0	0	0	0	0	0
SCI Control Register 3 (SCC3)	Read:	R8	T8	R	R	ORIE	NEIE	FEIE	PEIE
	Write:								
	Reset:	U	U	0	0	0	0	0	0
SCI Status Register 1 (SCS1)	Read:	SCTE	TC	SCRF	IDLE	OR	NF	FE	PE
	Write:								
	Reset:	1	1	0	0	0	0	0	0
SCI Status Register 2 (SCS2)	Read:	0	0	0	0	0	0	BKF	RPF
	Write:								
	Reset:	0	0	0	0	0	0	0	0
SCI Data Register (SCDR)	Read:	R7	R6	R5	R4	R3	R2	R1	R0
	Write:	T7	T6	T5	T4	T3	T2	T1	T0
	Reset:	Unaffected by Reset							
SCI Baud Rate Register (SCBR)	Read:	0	0	SCP1	SCP0	R	SCR2	SCR1	SCR0
	Write:								
	Reset:	0	0	0	0	0	0	0	0

= Unimplemented
 U = Unaffected
 R = Reserved

Figure 16-7. SCI I/O Receiver Register Summary

Table 16-4. SCI Receiver I/O Address Summary

Register	SCC1	SCC2	SCC3	SCS1	SCS2	SCDR	SCBR
Address	\$0013	\$0014	\$0015	\$0016	\$0017	\$0018	\$0019

16.5.3.1 Character Length

The receiver can accommodate either 8-bit or 9-bit data. The state of the M bit in SCI control register 1 (SCC1) determines character length. When receiving 9-bit data, bit R8 in SCI control register 2 (SCC2) is the ninth bit (bit 8). When receiving 8-bit data, bit R8 is a copy of the eighth bit (bit 7).

16.5.3.2 Character Reception

During an SCI reception, the receive shift register shifts characters in from the RxD pin. The SCI data register (SCDR) is the read-only buffer between the internal data bus and the receive shift register.

After a complete character shifts into the receive shift register, the data portion of the character transfers to the SCDR. The SCI receiver full bit, SCRF, in SCI status register 1 (SCS1) becomes set, indicating that the received byte can be read. If the SCI receive interrupt enable bit, SCRIE, in SCC2 is also set, the SCRF bit generates a receiver CPU interrupt request.

16.5.3.3 Data Sampling

The receiver samples the RxD pin at the RT clock rate. The RT clock is an internal signal with a frequency 16 times the baud rate. To adjust for baud rate mismatch, the RT clock is resynchronized at the following times (see [Figure 16-8](#)):

- After every start bit
- After the receiver detects a data bit change from logic 1 to logic 0 (after the majority of data bit samples at RT8, RT9, and RT10 returns a valid logic 1 and the majority of the next RT8, RT9, and RT10 samples returns a valid logic 0)

To locate the start bit, data recovery logic does an asynchronous search for a logic 0 preceded by three logic 1s. When the falling edge of a possible start bit occurs, the RT clock begins to count to 16.

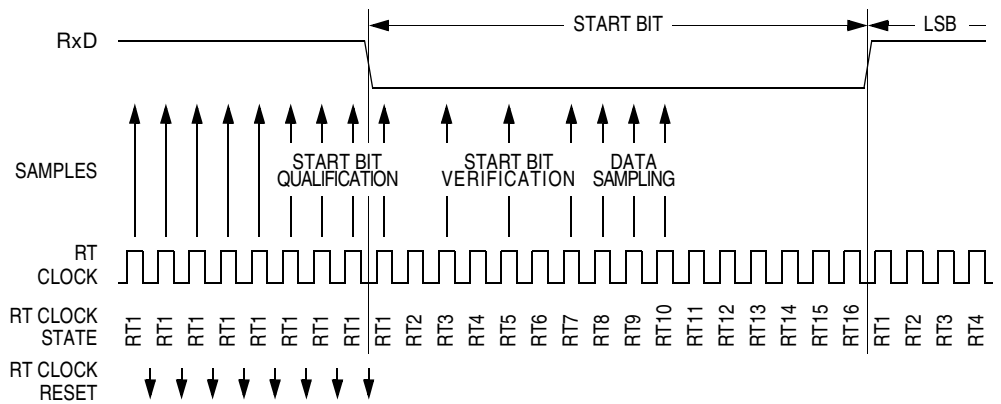

Figure 16-8. Receiver Data Sampling

To verify the start bit and to detect noise, data recovery logic takes samples at RT3, RT5, and RT7. [Table 16-5](#) summarizes the results of the start bit verification samples.

Table 16-5. Start Bit Verification

RT3, RT5, and RT7 Samples	Start Bit Verification	Noise Flag
000	Yes	0
001	Yes	1
010	Yes	1
011	No	0
100	Yes	1
101	No	0
110	No	0
111	No	0

If start bit verification is not successful, the RT clock is reset and a new search for a start bit begins.

To determine the value of a data bit and to detect noise, recovery logic takes samples at RT8, RT9, and RT10. [Table 16-6](#) summarizes the results of the data bit samples.

Table 16-6. Data Bit Recovery

RT8, RT9, and RT10 Samples	Data Bit Determination	Noise Flag
000	0	0
001	0	1
010	0	1
011	1	1
100	0	1
101	1	1
110	1	1
111	1	0

NOTE: *The RT8, RT9, and RT10 samples do not affect start bit verification. If any or all of the RT8, RT9, and RT10 start bit samples are logic 1s following a successful start bit verification, the noise flag (NF) is set and the receiver assumes that the bit is a start bit.*

To verify a stop bit and to detect noise, recovery logic takes samples at RT8, RT9, and RT10. [Table 16-7](#) summarizes the results of the stop bit samples.

Table 16-7. Stop Bit Recovery

RT8, RT9, and RT10 Samples	Framing Error Flag	Noise Flag
000	1	0
001	1	1
010	1	1
011	0	1
100	1	1
101	0	1
110	0	1
111	0	0

16.5.3.4 Framing Errors

If the data recovery logic does not detect a logic 1 where the stop bit should be in an incoming character, it sets the framing error bit, FE, in SCS1. A break character also sets the FE bit because a break character has no stop bit. The FE bit is set at the same time that the SCRF bit is set.

16.5.3.5 Baud Rate Tolerance

A transmitting device may be operating at a baud rate below or above the receiver baud rate. Accumulated bit time misalignment can cause one of the three stop bit data samples to fall outside the actual stop bit. Then a noise error occurs. If more than one of the samples is outside the stop bit, a framing error occurs. In most applications, the baud rate tolerance is much more than the degree of misalignment that is likely to occur.

As the receiver samples an incoming character, it resynchronizes the RT clock on any valid falling edge within the character. Resynchronization within characters corrects misalignments between transmitter bit times and receiver bit times.

Slow Data Tolerance

Figure 16-9 shows how much a slow received character can be misaligned without causing a noise error or a framing error. The slow stop bit begins at RT8 instead of RT1 but arrives in time for the stop bit data samples at RT8, RT9, and RT10.

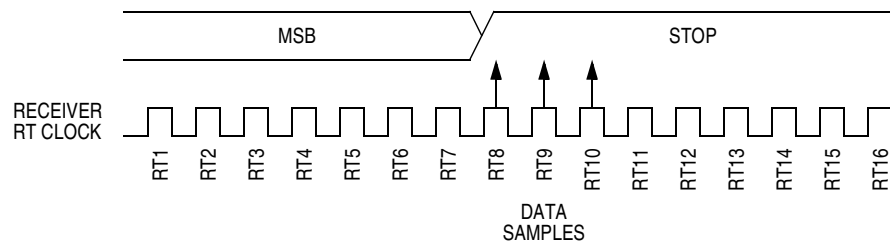

Figure 16-9. Slow Data

For an 8-bit character, data sampling of the stop bit takes the receiver 9 bit times \times 16 RT cycles + 10 RT cycles = 154 RT cycles.

With the misaligned character shown in **Figure 16-9**, the receiver counts 154 RT cycles at the point when the count of the transmitting device is 9 bit times \times 16 RT cycles + 3 RT cycles = 147 RT cycles.

The maximum percent difference between the receiver count and the transmitter count of a slow 8-bit character with no errors is

$$\left| \frac{154 - 147}{154} \right| \times 100 = 4.54\%$$

For a 9-bit character, data sampling of the stop bit takes the receiver 10 bit times \times 16 RT cycles + 10 RT cycles = 170 RT cycles.

With the misaligned character shown in **Figure 16-9**, the receiver counts 170 RT cycles at the point when the count of the transmitting device is 10 bit times \times 16 RT cycles + 3 RT cycles = 163 RT cycles.

The maximum percent difference between the receiver count and the transmitter count of a slow 9-bit character with no errors is

$$\left| \frac{170 - 163}{170} \right| \times 100 = 4.12\%$$

Fast Data Tolerance

Figure 16-10 shows how much a fast received character can be misaligned without causing a noise error or a framing error. The fast stop bit ends at RT10 instead of RT16 but is still there for the stop bit data samples at RT8, RT9, and RT10.

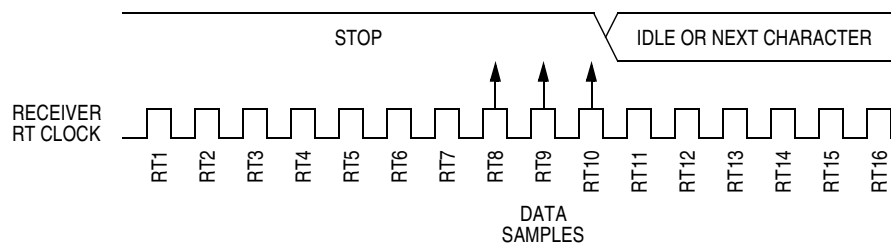

Figure 16-10. Fast Data

For an 8-bit character, data sampling of the stop bit takes the receiver 9 bit times \times 16 RT cycles + 10 RT cycles = 154 RT cycles.

With the misaligned character shown in [Figure 16-10](#), the receiver counts 154 RT cycles at the point when the count of the transmitting device is 10 bit times \times 16 RT cycles = 160 RT cycles.

The maximum percent difference between the receiver count and the transmitter count of a fast 8-bit character with no errors is

$$\left| \frac{154 - 160}{154} \right| \times 100 = 3.90\%.$$

For a 9-bit character, data sampling of the stop bit takes the receiver 10 bit times \times 16 RT cycles + 10 RT cycles = 170 RT cycles.

With the misaligned character shown in [Figure 16-10](#), the receiver counts 170 RT cycles at the point when the count of the transmitting device is 11 bit times \times 16 RT cycles = 176 RT cycles.

The maximum percent difference between the receiver count and the transmitter count of a fast 9-bit character with no errors is

$$\left| \frac{170 - 176}{170} \right| \times 100 = 3.53\%.$$

16.5.3.6 Receiver Wakeup

So that the MCU can ignore transmissions intended only for other receivers in multiple-receiver systems, the receiver can be put into a standby state. Setting the receiver wakeup bit, RWU, in SCC2 puts the receiver into a standby state during which receiver interrupts are disabled.

Depending on the state of the WAKE bit in SCC1, either of two conditions on the RxD pin can bring the receiver out of the standby state:

- **Address mark** — An address mark is a logic 1 in the most significant bit position of a received character. When the WAKE bit is set, an address mark wakes the receiver from the standby state by clearing the RWU bit. The address mark also sets the SCI receiver full bit, SCRF. Software can then compare the character containing the address mark to the user-defined address of the receiver. If they are the same, the receiver remains awake and

processes the characters that follow. If they are not the same, software can set the RWU bit and put the receiver back into the standby state.

- Idle input line condition — When the WAKE bit is clear, an idle character on the RxD pin wakes the receiver from the standby state by clearing the RWU bit. The idle character that wakes the receiver does not set the receiver idle bit, IDLE, or the SCI receiver full bit, SCRF. The idle line type bit, ILTY, determines whether the receiver begins counting logic 1s as idle character bits after the start bit or after the stop bit.

NOTE: *With the WAKE bit clear, setting the RWU bit after the RxD pin has been idle may cause the receiver to wake up immediately.*

16.5.3.7 Receiver Interrupts

The following sources can generate CPU interrupt requests from the SCI receiver:

- SCI receiver full (SCRF) — The SCRF bit in SCS1 indicates that the receive shift register has transferred a character to the SCDR. SCRF can generate a receiver CPU interrupt request. Setting the SCI receive interrupt enable bit, SCRIE, in SCC2 enables the SCRF bit to generate receiver CPU interrupts.
- Idle input (IDLE) — The IDLE bit in SCS1 indicates that 10 or 11 consecutive logic 1s shifted in from the RxD pin. The idle line interrupt enable bit, ILIE, in SCC2 enables the IDLE bit to generate CPU interrupt requests.

16.5.3.8 Error Interrupts

The following receiver error flags in SCS1 can generate CPU interrupt requests:

- Receiver overrun (OR) — The OR bit indicates that the receive shift register shifted in a new character before the previous character was read from the SCDR. The previous character

remains in the SCDR, and the new character is lost. The overrun interrupt enable bit, ORIE, in SCC3 enables OR to generate SCI error CPU interrupt requests.

- Noise flag (NF) — The NF bit is set when the SCI detects noise on incoming data or break characters, including start, data, and stop bits. The noise error interrupt enable bit, NEIE, in SCC3 enables NF to generate SCI error CPU interrupt requests.
- Framing error (FE) — The FE bit in SCS1 is set when a logic 0 occurs where the receiver expects a stop bit. The framing error interrupt enable bit, FEIE, in SCC3 enables FE to generate SCI error CPU interrupt requests.
- Parity error (PE) — The PE bit in SCS1 is set when the SCI detects a parity error in incoming data. The parity error interrupt enable bit, PEIE, in SCC3 enables PE to generate SCI error CPU interrupt requests.

16.6 Low-Power Modes

The WAIT and STOP instructions put the MCU in low power-consumption standby modes.

16.6.1 Wait Mode

The SCI module remains active in wait mode. Any enabled CPU interrupt request from the SCI module can bring the MCU out of wait mode.

If SCI module functions are not required during wait mode, reduce power consumption by disabling the module before executing the WAIT instruction.

16.6.2 Stop Mode

The SCI module is inactive in stop mode. The STOP instruction does not affect SCI register states. Any enabled CPU interrupt request from the

SCI module does not bring the MCU out of Stop mode. SCI module operation resumes after the MCU exits stop mode.

Because the internal clock is inactive during stop mode, entering stop mode during an SCI transmission or reception results in invalid data.

16.7 SCI During Break Module Interrupts

The BCFE bit in the break flag control register (BFCR) enables software to clear status bits during the break state. (See [Break Module \(BRK\)](#) on page 157).

To allow software to clear status bits during a break interrupt, write a logic 1 to the BCFE bit. If a status bit is cleared during the break state, it remains cleared when the MCU exits the break state.

To protect status bits during the break state, write a logic 0 to the BCFE bit. With BCFE at logic 0 (its default state), software can read and write I/O registers during the break state without affecting status bits. Some status bits have a two-step read/write clearing procedure. If software does the first step on such a bit before the break, the bit cannot change during the break state as long as BCFE is at logic 0. After the break, doing the second step clears the status bit.

16.8 I/O Signals

Port E shares two of its pins with the SCI module. The two SCI I/O pins are:

- PTE0/SCTxD — Transmit data
- PTE1/SCRxD — Receive data

16.8.1 PTE0/SCTxD (Transmit Data)

The PTE0/SCTxD pin is the serial data output from the SCI transmitter. The SCI shares the PTE0/SCTxD pin with port E. When the SCI is enabled, the PTE0/SCTxD pin is an output regardless of the state of the DDRE2 bit in data direction register E (DDRE).

16.8.2 PTE1/SCRxD (Receive Data)

The PTE1/SCRxD pin is the serial data input to the SCI receiver. The SCI shares the PTE1/SCRxD pin with port E. When the SCI is enabled, the PTE1/SCRxD pin is an input regardless of the state of the DDRE1 bit in data direction register E (DDRE).

16.9 I/O Registers

The following I/O registers control and monitor SCI operation:

- SCI control register 1 (SCC1)
- SCI control register 2 (SCC2)
- SCI control register 3 (SCC3)
- SCI status register 1 (SCS1)
- SCI status register 2 (SCS2)
- SCI data register (SCDR)
- SCI baud rate register (SCBR)

16.9.1 SCI Control Register 1

SCI control register 1:

- Enables loop mode operation
- Enables the SCI
- Controls output polarity
- Controls character length
- Controls SCI wakeup method

Serial Communications Interface (SCI)

- Controls idle character detection
- Enables parity function
- Controls parity type

Address: \$0013

	Bit 7	6	5	4	3	2	1	Bit 0
Read:	LOOPS	ENSCI	TXINV	M	WAKE	ILLTY	PEN	PTY
Write:								
Reset:	0	0	0	0	0	0	0	0

Figure 16-11. SCI Control Register 1 (SCC1)

LOOPS — Loop Mode Select Bit

This read/write bit enables loop mode operation. In loop mode the RxD pin is disconnected from the SCI, and the transmitter output goes into the receiver input. Both the transmitter and the receiver must be enabled to use loop mode. Reset clears the LOOPS bit.

1 = Loop mode enabled

0 = Normal operation enabled

ENSCI — Enable SCI Bit

This read/write bit enables the SCI and the SCI baud rate generator. Clearing ENSCI sets the SCTE and TC bits in SCI status register 1 and disables transmitter interrupts. Reset clears the ENSCI bit.

1 = SCI enabled

0 = SCI disabled

TXINV — Transmit Inversion Bit

This read/write bit reverses the polarity of transmitted data. Reset clears the TXINV bit.

1 = Transmitter output inverted

0 = Transmitter output not inverted

NOTE: *Setting the TXINV bit inverts all transmitted values, including idle, break, start, and stop bits.*

M — Mode (Character Length) Bit

This read/write bit determines whether SCI characters are eight or nine bits long. (See [Table 16-8](#)). The ninth bit can serve as an extra stop bit, as a receiver wakeup signal, or as a parity bit. Reset clears the M bit.

- 1 = 9-bit SCI characters
- 0 = 8-bit SCI characters

WAKE — Wakeup Condition Bit

This read/write bit determines which condition wakes up the SCI: a logic 1 (address mark) in the most significant bit position of a received character or an idle condition on the RxD pin. Reset clears the WAKE bit.

- 1 = Address mark wakeup
- 0 = Idle line wakeup

ILTY — Idle Line Type Bit

This read/write bit determines when the SCI starts counting logic 1s as idle character bits. The counting begins either after the start bit or after the stop bit. If the count begins after the start bit, then a string of logic 1s preceding the stop bit may cause false recognition of an idle character. Beginning the count after the stop bit avoids false idle character recognition, but requires properly synchronized transmissions. Reset clears the ILTY bit.

- 1 = Idle character bit count begins after stop bit
- 0 = Idle character bit count begins after start bit

PEN — Parity Enable Bit

This read/write bit enables the SCI parity function. (See [Table 16-8](#)). When enabled, the parity function inserts a parity bit in the most significant bit position. (See [Table 16-7](#)). Reset clears the PEN bit.

- 1 = Parity function enabled
- 0 = Parity function disabled

Serial Communications Interface (SCI)

PTY — Parity Bit

This read/write bit determines whether the SCI generates and checks for odd parity or even parity. (See [Table 16-8](#)). Reset clears the PTY bit.

1 = Odd parity

0 = Even parity

NOTE: *Changing the PTY bit in the middle of a transmission or reception can generate a parity error.*

Table 16-8. Character Format Selection

Control Bits		Character Format				
M	PEN:PTY	Start Bits	Data Bits	Parity	Stop Bits	Character Length
0	0X	1	8	None	1	10 Bits
1	0X	1	9	None	1	11 Bits
0	10	1	7	Even	1	10 Bits
0	11	1	7	Odd	1	10 Bits
1	10	1	8	Even	1	11 Bits
1	11	1	8	Odd	1	11 Bits

16.9.2 SCI Control Register 2

SCI control register 2:

- Enables the following CPU interrupt requests:
 - Enables the SCTE bit to generate transmitter CPU interrupt requests
 - Enables the TC bit to generate transmitter CPU interrupt requests
 - Enables the SCRF bit to generate receiver CPU interrupt requests
 - Enables the IDLE bit to generate receiver CPU interrupt requests

- Enables the transmitter
- Enables the receiver
- Enables SCI wakeup
- Transmits SCI break characters

Address: \$0014

	Bit 7	6	5	4	3	2	1	Bit 0
Read:	SCTIE	TCIE	SCRIE	ILIE	TE	RE	RWU	SBK
Write:								
Reset:	0	0	0	0	0	0	0	0

Figure 16-12. SCI Control Register 2 (SCC2)

SCTIE — SCI Transmit Interrupt Enable Bit

This read/write bit enables the SCTE bit to generate SCI transmitter CPU interrupt requests. Setting the SCTIE bit in SCC3 enables the SCTE bit to generate CPU interrupt requests. Reset clears the SCTIE bit.

- 1 = SCTE enabled to generate CPU interrupt
- 0 = SCTE not enabled to generate CPU interrupt

TCIE — Transmission Complete Interrupt Enable Bit

This read/write bit enables the TC bit to generate SCI transmitter CPU interrupt requests. Reset clears the TCIE bit.

- 1 = TC enabled to generate CPU interrupt requests
- 0 = TC not enabled to generate CPU interrupt requests

SCRIE — SCI Receive Interrupt Enable Bit

This read/write bit enables the SCRF bit to generate SCI receiver CPU interrupt requests. Setting the SCRIE bit in SCC3 enables the SCRF bit to generate CPU interrupt requests. Reset clears the SCRIE bit.

- 1 = SCRF enabled to generate CPU interrupt
- 0 = SCRF not enabled to generate CPU interrupt

ILIE — Idle Line Interrupt Enable Bit

This read/write bit enables the IDLE bit to generate SCI receiver CPU interrupt requests. Reset clears the ILIE bit.

- 1 = IDLE enabled to generate CPU interrupt requests
- 0 = IDLE not enabled to generate CPU interrupt requests

TE — Transmitter Enable Bit

Setting this read/write bit begins the transmission by sending a preamble of 10 or 11 logic 1s from the transmit shift register to the TxD pin. If software clears the TE bit, the transmitter completes any transmission in progress before the TxD returns to the idle condition (logic 1). Clearing and then setting TE during a transmission queues an idle character to be sent after the character currently being transmitted. Reset clears the TE bit.

- 1 = Transmitter enabled
- 0 = Transmitter disabled

NOTE: *Writing to the TE bit is not allowed when the enable SCI bit (ENSCI) is clear. ENSCI is in SCI control register 1.*

RE — Receiver Enable Bit

Setting this read/write bit enables the receiver. Clearing the RE bit disables the receiver but does not affect receiver interrupt flag bits.

Reset clears the RE bit.

- 1 = Receiver enabled
- 0 = Receiver disabled

NOTE: *Writing to the RE bit is not allowed when the enable SCI bit (ENSCI) is clear. ENSCI is in SCI control register 1.*

RWU — Receiver Wakeup Bit

This read/write bit puts the receiver in a standby state during which receiver interrupts are disabled. The WAKE bit in SCC1 determines whether an idle input or an address mark brings the receiver out of the standby state and clears the RWU bit. Reset clears the RWU bit.

- 1 = Standby state
- 0 = Normal operation

SBK — Send Break Bit

Setting and then clearing this read/write bit transmits a break character followed by a logic 1. The logic 1 after the break character guarantees recognition of a valid start bit. If SBK remains set, the transmitter continuously transmits break characters with no logic 1s between them. Reset clears the SBK bit.

- 1 = Transmit break characters
- 0 = No break characters being transmitted

NOTE: *Do not toggle the SBK bit immediately after setting the SCTE bit. Toggling SBK before the preamble begins causes the SCI to send a break character instead of a preamble.*

16.9.3 SCI Control Register 3

SCI control register 3:

- Stores the ninth SCI data bit received and the ninth SCI data bit to be transmitted.
- Enables the following interrupts:
 - Receiver overrun interrupts
 - Noise error interrupts
 - Framing error interrupts
 - Parity error interrupts

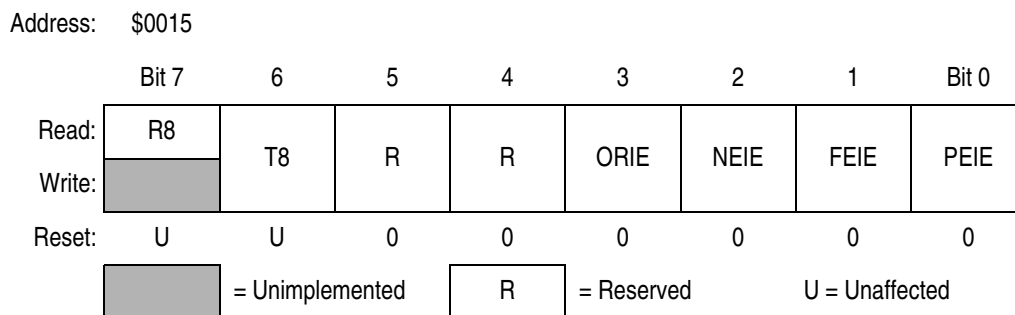

Figure 16-13. SCI Control Register 3 (SCC3)

R8 — Received Bit 8

When the SCI is receiving 9-bit characters, R8 is the read-only ninth bit (bit 8) of the received character. R8 is received at the same time that the SCDR receives the other 8 bits.

When the SCI is receiving 8-bit characters, R8 is a copy of the eighth bit (bit 7). Reset has no effect on the R8 bit.

T8 — Transmitted Bit 8

When the SCI is transmitting 9-bit characters, T8 is the read/write ninth bit (bit 8) of the transmitted character. T8 is loaded into the transmit shift register at the same time that the SCDR is loaded into the transmit shift register. Reset has no effect on the T8 bit.

ORIE — Receiver Overrun Interrupt Enable Bit

This read/write bit enables SCI error CPU interrupt requests generated by the receiver overrun bit, OR.

- 1 = SCI error CPU interrupt requests from OR bit enabled
- 0 = SCI error CPU interrupt requests from OR bit disabled

NEIE — Receiver Noise Error Interrupt Enable Bit

This read/write bit enables SCI error CPU interrupt requests generated by the noise error bit, NE. Reset clears NEIE.

- 1 = SCI error CPU interrupt requests from NE bit enabled
- 0 = SCI error CPU interrupt requests from NE bit disabled

FEIE — Receiver Framing Error Interrupt Enable Bit

This read/write bit enables SCI error CPU interrupt requests generated by the framing error bit, FE. Reset clears FEIE.

- 1 = SCI error CPU interrupt requests from FE bit enabled
- 0 = SCI error CPU interrupt requests from FE bit disabled

PEIE — Receiver Parity Error Interrupt Enable Bit

This read/write bit enables SCI receiver CPU interrupt requests generated by the parity error bit, PE. Reset clears PEIE.

- 1 = SCI error CPU interrupt requests from PE bit enabled
- 0 = SCI error CPU interrupt requests from PE bit disabled

16.9.4 SCI Status Register 1

SCI status register 1 contains flags to signal the following conditions:

- Transfer of SCDR data to transmit shift register complete
- Transmission complete
- Transfer of receive shift register data to SCDR complete
- Receiver input idle
- Receiver overrun
- Noisy data
- Framing error
- Parity error

Address: \$0016

	Bit 7	6	5	4	3	2	1	Bit 0
Read:	SCTE	TC	SCRF	IDLE	OR	NF	FE	PE
Write:								
Reset:	1	1	0	0	0	0	0	0

 = Unimplemented

Figure 16-14. SCI Status Register 1 (SCS1)

SCTE — SCI Transmitter Empty Bit

This clearable, read-only bit is set when the SCDR transfers a character to the transmit shift register. SCTE can generate an SCI transmitter CPU interrupt request. When the SCTIE bit in SCC2 is set, SCTE generates an SCI transmitter CPU interrupt request. In normal operation, clear the SCTE bit by reading SCS1 with SCTE set and then writing to SCDR. Reset sets the SCTE bit.

- 1 = SCDR data transferred to transmit shift register
- 0 = SCDR data not transferred to transmit shift register

TC — Transmission Complete Bit

This read-only bit is set when the SCTE bit is set, and no data, preamble, or break character is being transmitted. TC generates an SCI transmitter CPU interrupt request if the TCIE bit in SCC2 is also set. TC is cleared automatically when data, preamble, or break is queued and ready to be sent. There may be up to 1.5 transmitter clocks of latency between queuing data, preamble, and break and the transmission actually starting. Reset sets the TC bit.

- 1 = No transmission in progress
- 0 = Transmission in progress

SCRF — SCI Receiver Full Bit

This clearable, read-only bit is set when the data in the receive shift register transfers to the SCI data register. SCRF can generate an SCI receiver CPU interrupt request. When the SCRIE bit in SCC2 is set the SCRF generates a CPU interrupt request. In normal operation, clear the SCRF bit by reading SCS1 with SCRF set and then reading the SCDR. Reset clears SCRF.

- 1 = Received data available in SCDR
- 0 = Data not available in SCDR

IDLE — Receiver Idle Bit

This clearable, read-only bit is set when 10 or 11 consecutive logic 1s appear on the receiver input. IDLE generates an SCI error CPU interrupt request if the ILIE bit in SCC2 is also set. Clear the IDLE bit by reading SCS1 with IDLE set and then reading the SCDR. After the receiver is enabled, it must receive a valid character that sets the SCRF bit before an idle condition can set the IDLE bit. Also, after the IDLE bit has been cleared, a valid character must again set the SCRF bit before an idle condition can set the IDLE bit. Reset clears the IDLE bit.

- 1 = Receiver input idle
- 0 = Receiver input active (or idle since the IDLE bit was cleared)

OR — Receiver Overrun Bit

This clearable, read-only bit is set when software fails to read the SCDR before the receive shift register receives the next character. The OR bit generates an SCI error CPU interrupt request if the ORIE

Serial Communications Interface (SCI)

bit in SCC3 is also set. The data in the shift register is lost, but the data already in the SCDR is not affected. Clear the OR bit by reading SCS1 with OR set and then reading the SCDR. Reset clears the OR bit.

1 = Receive shift register full and SCRF = 1

0 = No receiver overrun

Software latency may allow an overrun to occur between reads of SCS1 and SCDR in the flag-clearing sequence. **Figure 16-15** shows the normal flag-clearing sequence and an example of an overrun caused by a delayed flag-clearing sequence. The delayed read of SCDR does not clear the OR bit because OR was not set when SCS1 was read. Byte 2 caused the overrun and is lost. The next flag-clearing sequence reads byte 3 in the SCDR instead of byte 2.

In applications that are subject to software latency or in which it is important to know which byte is lost due to an overrun, the flag-clearing routine can check the OR bit in a second read of SCS1 after reading the data register.

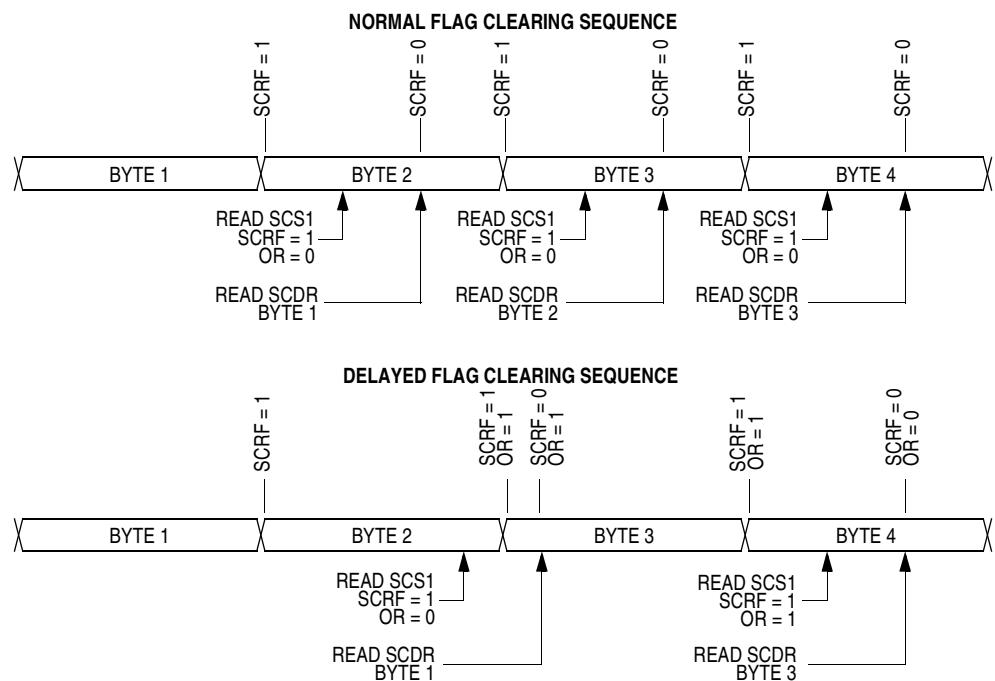

Figure 16-15. Flag Clearing Sequence

NF — Receiver Noise Flag Bit

This clearable, read-only bit is set when the SCI detects noise on the RxD pin. NF generates an NF CPU interrupt request if the NEIE bit in SCC3 is also set. Clear the NF bit by reading SCS1 and then reading the SCDR. Reset clears the NF bit.

1 = Noise detected

0 = No noise detected

FE — Receiver Framing Error Bit

This clearable, read-only bit is set when a logic 0 is accepted as the stop bit. FE generates an SCI error CPU interrupt request if the FEIE bit in SCC3 also is set. Clear the FE bit by reading SCS1 with FE set and then reading the SCDR. Reset clears the FE bit.

1 = Framing error detected

0 = No framing error detected

PE — Receiver Parity Error Bit

This clearable, read-only bit is set when the SCI detects a parity error in incoming data. PE generates a PE CPU interrupt request if the PEIE bit in SCC3 is also set. Clear the PE bit by reading SCS1 with PE set and then reading the SCDR. Reset clears the PE bit.

1 = Parity error detected

0 = No parity error detected

16.9.5 SCI Status Register 2

SCI status register 2 contains flags to signal the following conditions:

- Break character detected
- Incoming data

Address: \$0017

	Bit 7	6	5	4	3	2	1	Bit 0
Read:	0	0	0	0	0	0	BKF	RPF
Write:								
Reset:	0	0	0	0	0	0	0	0

 = Unimplemented

Figure 16-16. SCI Status Register 2 (SCS2)

BKF — Break Flag Bit

This clearable, read-only bit is set when the SCI detects a break character on the RxD pin. In SCS1, the FE and SCRF bits are also set. In 9-bit character transmissions, the R8 bit in SCC3 is cleared. BKF does not generate a CPU interrupt request. Clear BKF by reading SCS2 with BKF set and then reading the SCDR. Once cleared, BKF can become set again only after logic 1s again appear on the RxD pin followed by another break character. Reset clears the BKF bit.

- 1 = Break character detected
- 0 = No break character detected

RPF — Reception in Progress Flag Bit

This read-only bit is set when the receiver detects a logic 0 during the RT1 time period of the start bit search. RPF does not generate an interrupt request. RPF is reset after the receiver detects false start bits (usually from noise or a baud rate mismatch), or when the receiver detects an idle character. Polling RPF before disabling the SCI module or entering stop mode can show whether a reception is in progress.

- 1 = Reception in progress
- 0 = No reception in progress

16.9.6 SCI Data Register

The SCI data register is the buffer between the internal data bus and the receive and transmit shift registers. Reset has no effect on data in the SCI data register.

Address: \$0018

	Bit 7	6	5	4	3	2	1	Bit 0
Read:	R7	R6	R5	R4	R3	R2	R1	R0
Write:	T7	T6	T5	T4	T3	T2	T1	T0
Reset:	Unaffected by Reset							

Figure 16-17. SCI Data Register (SCDR)

R7/T7:R0/T0 — Receive/Transmit Data Bits

Reading address \$0018 accesses the read-only received data bits, R7:R0. Writing to address \$0018 writes the data to be transmitted, T7:T0. Reset has no effect on the SCI data register.

NOTE: Do not use read-modify-write instructions on the SCI data register.

16.9.7 SCI Baud Rate Register

The baud rate register selects the baud rate for both the receiver and the transmitter.

Address: \$0019

	Bit 7	6	5	4	3	2	1	Bit 0
Read:	0	0	SCP1	SCP0	R	SCR2	SCR1	SCR0
Write:								
Reset:	0	0	0	0	0	0	0	0

= Unimplemented
 R = Reserved

Figure 16-18. SCI Baud Rate Register (SCBR)

Serial Communications Interface (SCI)

SCP1 and SCP0 — SCI Baud Rate Prescaler Bits

These read/write bits select the baud rate prescaler divisor as shown in [Table 16-9](#). Reset clears SCP1 and SCP0.

Table 16-9. SCI Baud Rate Prescaling

SCP[1:0]	Prescaler Divisor (PD)
00	1
01	3
10	4
11	13

SCR2 – SCR0 — SCI Baud Rate Select Bits

These read/write bits select the SCI baud rate divisor as shown in [Table 16-10](#). Reset clears SCR2–SCR0.

Table 16-10. SCI Baud Rate Selection

SCR[2:1:0]	Baud Rate Divisor (BD)
000	1
001	2
010	4
011	8
100	16
101	32
110	64
111	128

Use the following formula to calculate the SCI baud rate:

$$\text{Baud rate} = \frac{f_{\text{Crystal}}}{64 \times \text{PD} \times \text{BD}}$$

where:

f_{Crystal} = crystal frequency

PD = prescaler divisor

BD = baud rate divisor

Table 16-11 shows the SCI baud rates that can be generated with a 4.9152-MHz crystal.

Table 16-11. SCI Baud Rate Selection Examples

SCP[1:0]	Prescaler Divisor (PD)	SCR[2:1:0]	Baud Rate Divisor (BD)	Baud Rate (f _{Crystal} = 4.9152 MHz)
00	1	000	1	76,800
00	1	001	2	38,400
00	1	010	4	19,200
00	1	011	8	9600
00	1	100	16	4800
00	1	101	32	2400
00	1	110	64	1200
00	1	111	128	600
01	3	000	1	25,600
01	3	001	2	12,800
01	3	010	4	6400
01	3	011	8	3200
01	3	100	16	1600
01	3	101	32	800
01	3	110	64	400
01	3	111	128	200
10	4	000	1	19,200
10	4	001	2	9600
10	4	010	4	4800
10	4	011	8	2400
10	4	100	16	1200
10	4	101	32	600
10	4	110	64	300
10	4	111	128	150
11	13	000	1	5908
11	13	001	2	2954
11	13	010	4	1477
11	13	011	8	739
11	13	100	16	369
11	13	101	32	185
11	13	110	64	92
11	13	111	128	46

Serial Communications Interface (SCI)

Section 17. Serial Peripheral Interface (SPI)

17.1 Contents

17.2	Introduction	236
17.3	Features	236
17.4	Pin Name and Register Name Conventions	237
17.5	Functional Description	238
17.5.1	Master Mode	240
17.5.2	Slave Mode	241
17.6	Transmission Formats	242
17.6.1	Clock Phase and Polarity Controls	242
17.6.2	Transmission Format When CPHA = 0	243
17.6.3	Transmission Format When CPHA = 1	244
17.6.4	Transmission Initiation Latency	245
17.7	Error Conditions	247
17.7.1	Overflow Error	247
17.7.2	Mode Fault Error	249
17.8	Interrupts	251
17.9	Queuing Transmission Data	252
17.10	Resetting the SPI	254
17.11	Low-Power Modes	255
17.11.1	Wait Mode	255
17.11.2	Stop Mode	255
17.12	SPI During Break Interrupts	255
17.13	I/O Signals	256
17.13.1	MISO (Master In/Slave Out)	257
17.13.2	MOSI (Master Out/Slave In)	257

17.13.3	SPSCK (Serial Clock)	257
17.13.4	SS (Slave Select)	258
17.13.5	V _{SS} (Clock Ground)	259
17.14	I/O Registers	259
17.14.1	SPI Control Register	260
17.14.2	SPI Status and Control Register	262
17.14.3	SPI Data Register	266

17.2 Introduction

This section describes the serial peripheral interface (SPI) module, which allows full-duplex, synchronous, serial communications with peripheral devices.

17.3 Features

Features of the SPI module include:

- Full-Duplex Operation
- Master and Slave Modes
- Double-Buffered Operation with Separate Transmit and Receive Registers
- Four Master Mode Frequencies (Maximum = Bus Frequency ÷ 2)
- Maximum Slave Mode Frequency = Bus Frequency
- Serial Clock with Programmable Polarity and Phase
- Two Separately Enabled Interrupts with CPU Service:
 - SPRF (SPI Receiver Full)
 - SPTE (SPI Transmitter Empty)
- Mode Fault Error Flag with CPU Interrupt Capability
- Overflow Error Flag with CPU Interrupt Capability
- Programmable Wired-OR Mode
- I²C (Inter-Integrated Circuit) Compatibility

17.4 Pin Name and Register Name Conventions

The generic names of the SPI input/output (I/O) pins are:

- \overline{SS} (slave select)
- SPSCCK (SPI serial clock)
- MOSI (master out slave in)
- MISO (master in slave out)

The SPI shares four I/O pins with a parallel I/O port. The full name of an SPI pin reflects the name of the shared port pin. [Table 17-1](#) shows the full names of the SPI I/O pins. The generic pin names appear in the text that follows.

Table 17-1. Pin Name Conventions

SPI Generic Pin Name	MISO	MOSI	\overline{SS}	SPSCCK
Full SPI Pin Name	PTE5/MISO	PTE6/MOSI	PTE4/ \overline{SS}	PTE7/SPSCCK

The generic names of the SPI I/O registers are:

- SPI control register (SPCR)
- SPI status and control register (SPSCR)
- SPI data register (SPDR)

[Table 17-2](#) shows the names and the addresses of the SPI I/O registers.

Table 17-2. I/O Register Addresses

Register Name	Address
SPI Control Register (SPCR)	\$0010
SPI Status and Control Register (SPSCR)	\$0011
SPI Data Register (SPDR)	\$0012

Serial Peripheral Interface (SPI)

17.5 Functional Description

Table 17-3 summarizes the SPI I/O registers and **Figure 17-1** shows the structure of the SPI module.

Table 17-3. SPI I/O Register Summary

Addr	Register Name	R/W	Bit 7	6	5	4	3	2	1	Bit 0
\$0010	SPI Control Register (SPCR)	Read:	SPRIE	R	SPMSTR	CPOL	CPHA	SPWOM	SPE	SPTIE
		Write:								
		Reset:	0	0	1	0	1	0	0	0
\$0011	SPI Status and Control Register (SPSCR)	Read:	SPRF	ERRIE	OVRF	MODF	SPTE	MODFEN	SPR1	SPR0
		Write:								
		Reset:	0	0	0	0	1	0	0	0
\$0012	SPI Data Register (SPDR)	Read:	R7	R6	R5	R4	R3	R2	R1	R0
		Write:	T7	T6	T5	T4	T3	T2	T1	T0
		Reset:	Unaffected by Reset							
			R	= Reserved			= Unimplemented			

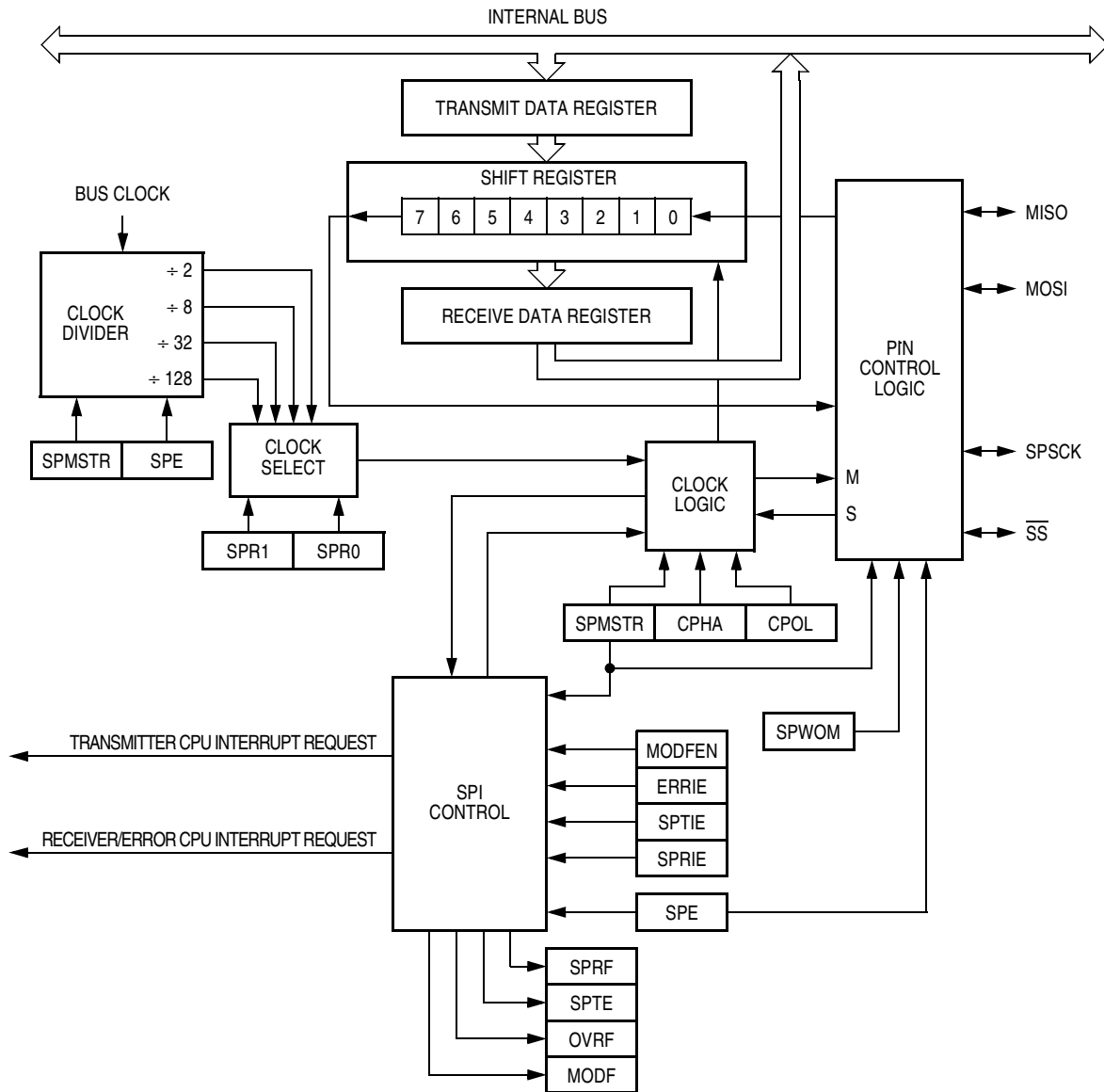

Figure 17-1. SPI Module Block Diagram

The SPI module allows full-duplex, synchronous, serial communication between the MCU and peripheral devices, including other MCUs. Software can poll the SPI status flags or SPI operation can be interrupt driven. All SPI interrupts can be serviced by the CPU.

The following paragraphs describe the operation of the SPI module.

Serial Peripheral Interface (SPI)

17.5.1 Master Mode

The SPI operates in master mode when the SPI master bit, SPMSTR (SPCR \$0010), is set.

NOTE: *Configure the SPI modules as master and slave before enabling them. Enable the master SPI before enabling the slave SPI. Disable the slave SPI before disabling the master SPI. See [SPI Control Register](#) on page 260.*

Only a master SPI module can initiate transmissions. Software begins the transmission from a master SPI module by writing to the SPI data register. If the shift register is empty, the byte immediately transfers to the shift register, setting the SPI transmitter empty bit, SPTE (SPSCR \$0011). The byte begins shifting out on the MOSI pin under the control of the serial clock. (See [Table 17-4](#)).

The SPR1 and SPR0 bits control the baud rate generator and determine the speed of the shift register. (See [SPI Status and Control Register](#) on page 262). Through the SPSCCK pin, the baud rate generator of the master also controls the shift register of the slave peripheral.

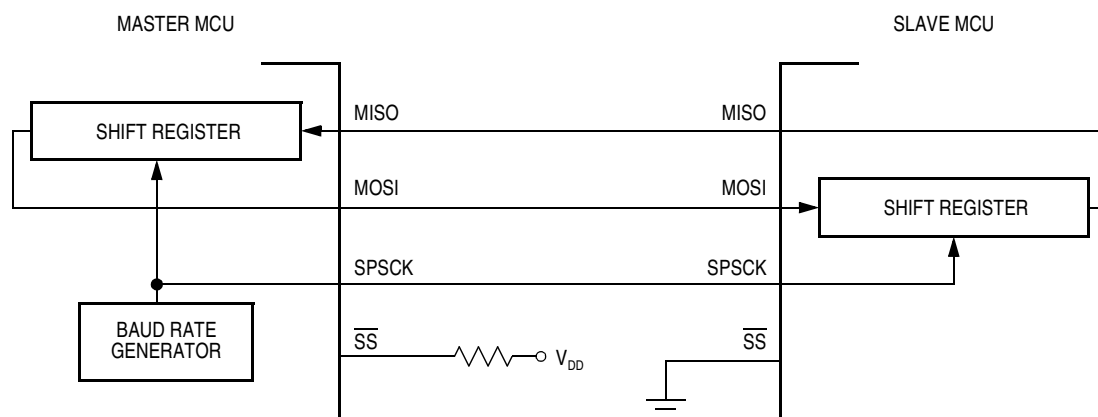

Figure 17-2. Full-Duplex Master-Slave Connections

As the byte shifts out on the MOSI pin of the master, another byte shifts in from the slave on the master's MISO pin. The transmission ends when the receiver full bit, SPRF (SPSCR), becomes set. At the same time that SPRF becomes set, the byte from the slave transfers to the receive data register. In normal operation, SPRF signals the end of a transmission. Software clears SPRF by reading the SPI status and control register and then reading the SPI data register. Writing to the SPI data register clears the SPTIE bit.

17.5.2 Slave Mode

The SPI operates in slave mode when the SPMSTR bit (SPCR, \$0010) is clear. In slave mode the SPSCCK pin is the input for the serial clock from the master MCU. Before a data transmission occurs, the \overline{SS} pin of the slave MCU must be at logic 0. \overline{SS} must remain low until the transmission is complete. (See [Mode Fault Error](#) on page 249).

In a slave SPI module, data enters the shift register under the control of the serial clock from the master SPI module. After a byte enters the shift register of a slave SPI, it is transferred to the receive data register, and the SPRF bit (SPSCR) is set. To prevent an overflow condition, slave software then must read the SPI data register before another byte enters the shift register.

The maximum frequency of the SPSCCK for an SPI configured as a slave is the bus clock speed, which is twice as fast as the fastest master SPSCCK clock that can be generated. The frequency of the SPSCCK for an SPI configured as a slave does not have to correspond to any SPI baud rate. The baud rate only controls the speed of the SPSCCK generated by an SPI configured as a master. Therefore, the frequency of the SPSCCK for an SPI configured as a slave can be any frequency less than or equal to the bus speed.

When the master SPI starts a transmission, the data in the slave shift register begins shifting out on the MISO pin. The slave can load its shift register with a new byte for the next transmission by writing to its transmit data register. The slave must write to its transmit data register at least one bus cycle before the master starts the next transmission. Otherwise the byte already in the slave shift register shifts out on the MISO pin.

Data written to the slave shift register during a transmission remains in a buffer until the end of the transmission.

When the clock phase bit (CPHA) is set, the first edge of \overline{SPSCK} starts a transmission. When CPHA is clear, the falling edge of \overline{SS} starts a transmission. See [Transmission Formats](#) on page 242.

If the write to the data register is late, the SPI transmits the data already in the shift register from the previous transmission.

NOTE: *To prevent SPSCK from appearing as a clock edge, SPSCK must be in the proper idle state before the slave is enabled.*

17.6 Transmission Formats

During an SPI transmission, data is simultaneously transmitted (shifted out serially) and received (shifted in serially). A serial clock line synchronizes shifting and sampling on the two serial data lines. A slave select line allows individual selection of a slave SPI device; slave devices that are not selected do not interfere with SPI bus activities. On a master SPI device, the slave select line can be used optionally to indicate a multiple-master bus contention.

17.6.1 Clock Phase and Polarity Controls

Software can select any of four combinations of serial clock (SCK) phase and polarity using two bits in the SPI control register (SPCR). The clock polarity is specified by the CPOL control bit, which selects an active high or low clock and has no significant effect on the transmission format.

The clock phase (CPHA) control bit (SPCR) selects one of two fundamentally different transmission formats. The clock phase and polarity should be identical for the master SPI device and the communicating slave device. In some cases, the phase and polarity are changed between transmissions to allow a master device to communicate with peripheral slaves having different requirements.

NOTE: *Before writing to the CPOL bit or the CPHA bit (SPCR), disable the SPI by clearing the SPI enable bit (SPE).*

17.6.2 Transmission Format When CPHA = 0

Figure 17-3 shows an SPI transmission in which CPHA (SPCR) is logic 0. The figure should not be used as a replacement for data sheet parametric information. Two waveforms are shown for SCK: one for CPOL = 0 and another for CPOL = 1. The diagram may be interpreted as a master or slave timing diagram since the serial clock (SCK), master in/slave out (MISO), and master out/slave in (MOSI) pins are directly connected between the master and the slave. The MISO signal is the output from the slave, and the MOSI signal is the output from the master. The \overline{SS} line is the slave select input to the slave. The slave SPI drives its MISO output only when its slave select input (\overline{SS}) is at logic 0, so that only the selected slave drives to the master. The \overline{SS} pin of the master is not shown but is assumed to be inactive. The \overline{SS} pin of the master must be high or must be reconfigured as general-purpose I/O not affecting the SPI (see **Mode Fault Error** on page 249). When CPHA = 0, the first SPSCK edge is the MSB capture strobe. Therefore, the slave must begin driving its data before the first SPSCK edge, and a falling edge on the \overline{SS} pin is used to start the transmission. The \overline{SS} pin must be toggled high and then low again between each byte transmitted.

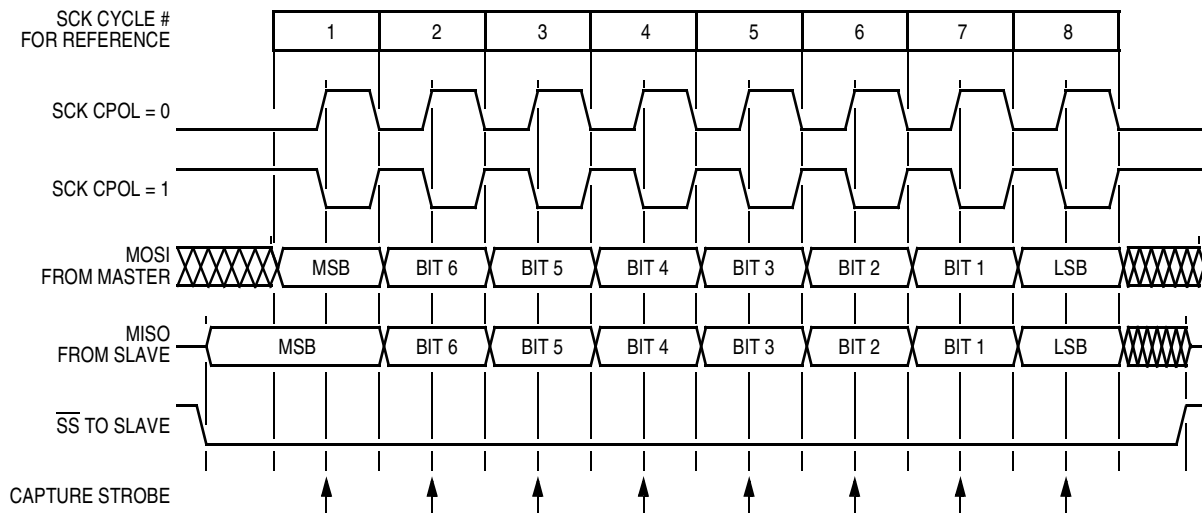

Figure 17-3. Transmission Format (CPHA = 0)

17.6.3 Transmission Format When CPHA = 1

Figure 17-4 shows an SPI transmission in which CPHA (SPCR) is logic 1. The figure should not be used as a replacement for data sheet parametric information. Two waveforms are shown for SCK: one for CPOL = 0 and another for CPOL = 1. The diagram may be interpreted as a master or slave timing diagram since the serial clock (SCK), master in/slave out (MISO), and master out/slave in (MOSI) pins are directly connected between the master and the slave. The MISO signal is the output from the slave, and the MOSI signal is the output from the master. The \overline{SS} line is the slave select input to the slave. The slave SPI drives its MISO output only when its slave select input (\overline{SS}) is at logic 0, so that only the selected slave drives to the master. The \overline{SS} pin of the master is not shown but is assumed to be inactive. The \overline{SS} pin of the master must be high or must be reconfigured as general-purpose I/O not affecting the SPI. (See **Mode Fault Error** on page 249). When CPHA = 1, the master begins driving its MOSI pin on the first SPSCCK edge. Therefore, the slave uses the first SPSCCK edge as a start transmission signal. The \overline{SS} pin can remain low between transmissions. This format may be preferable in systems having only one master and only one slave driving the MISO data line.

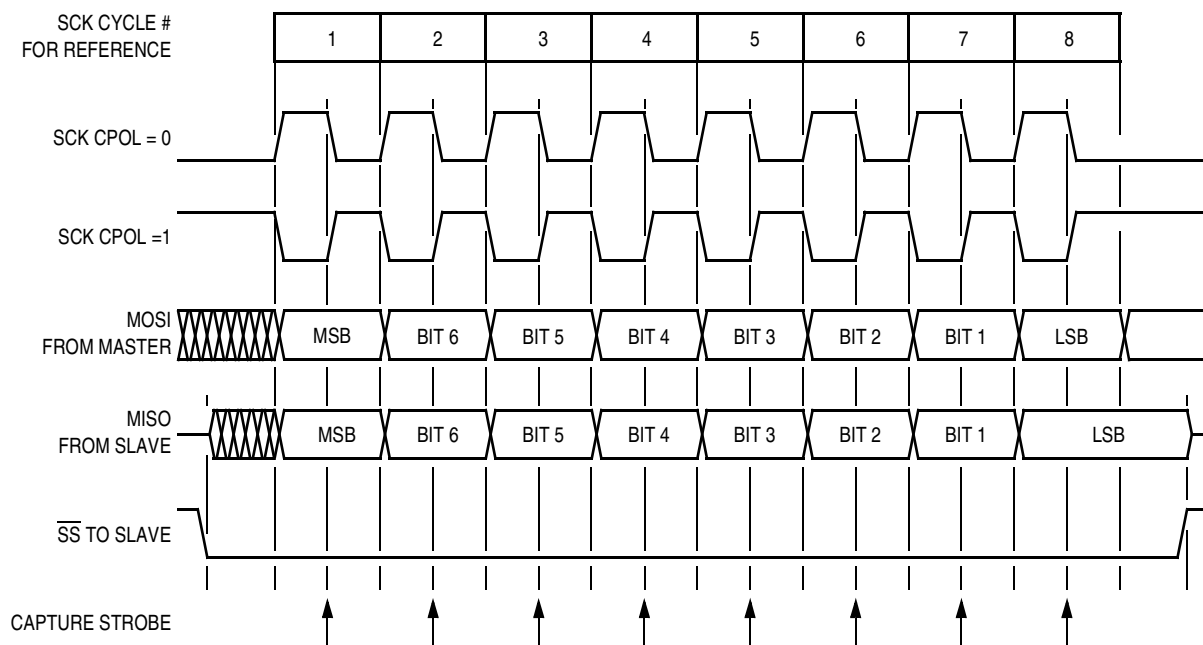

Figure 17-4. Transmission Format (CPHA = 1)

17.6.4 Transmission Initiation Latency

When the SPI is configured as a master ($SPMSTR = 1$), transmissions are started by a software write to the SPDR (\$0012). $CPHA$ has no effect on the delay to the start of the transmission, but it does affect the initial state of the SCK signal. When $CPHA = 0$, the SCK signal remains inactive for the first half of the first SCK cycle. When $CPHA = 1$, the first SCK cycle begins with an edge on the SCK line from its inactive to its active level. The SPI clock rate (selected by $SPR1$ – $SPR0$) affects the delay from the write to SPDR and the start of the SPI transmission. (See [Figure 17-5](#)). The internal SPI clock in the master is a free-running derivative of the internal MCU clock. It is only enabled when both the SPE and $SPMSTR$ bits ($SPCR$) are set to conserve power. SCK edges occur half way through the low time of the internal MCU clock. Since the SPI clock is free-running, it is uncertain where the write to the SPDR will occur relative to the slower SCK. This uncertainty causes the variation in the initiation delay shown in [Figure 17-5](#). This delay will be no longer than a single SPI bit time. That is, the maximum delay between the write to SPDR and the start of the SPI transmission is two MCU bus cycles for $DIV2$, eight MCU bus cycles for $DIV8$, 32 MCU bus cycles for $DIV32$, and 128 MCU bus cycles for $DIV128$.

Serial Peripheral Interface (SPI)

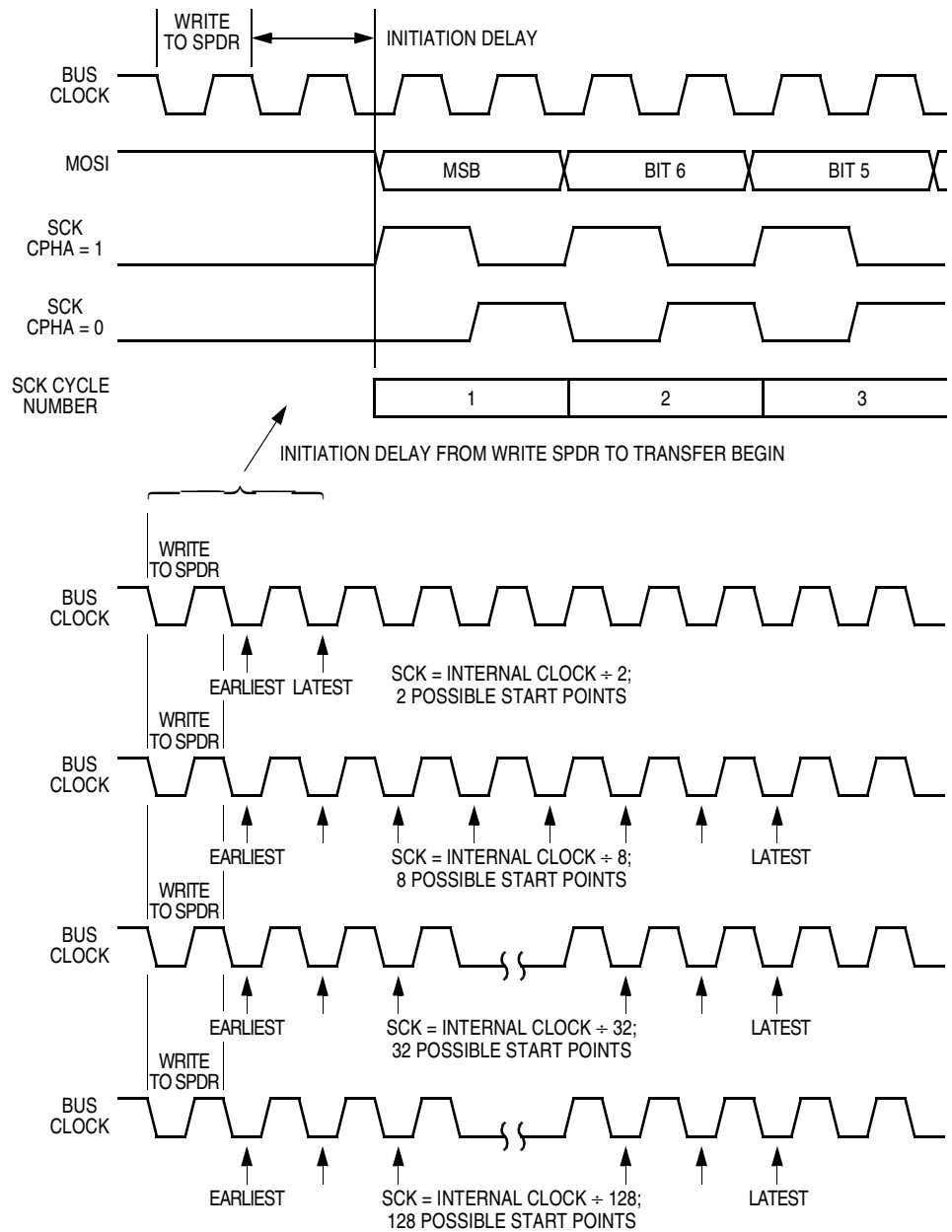

Figure 17-5. Transmission Start Delay (Master)

17.7 Error Conditions

Two flags signal SPI error conditions:

1. Overflow (OVRF in SPSCR) — Failing to read the SPI data register before the next byte enters the shift register sets the OVRF bit. The new byte does not transfer to the receive data register, and the unread byte still can be read by accessing the SPI data register. OVRF is in the SPI status and control register.
2. Mode fault error (MODF in SPSCR) — The MODF bit indicates that the voltage on the slave select pin (\overline{SS}) is inconsistent with the mode of the SPI. MODF is in the SPI status and control register.

17.7.1 Overflow Error

The overflow flag (OVRF in SPSCR) becomes set if the SPI receive data register still has unread data from a previous transmission when the capture strobe of bit 1 of the next transmission occurs. (See [Figure 17-3](#) and [Figure 17-4](#).) If an overflow occurs, the data being received is not transferred to the receive data register so that the unread data can still be read. Therefore, an overflow error always indicates the loss of data.

OVRF generates a receiver/error CPU interrupt request if the error interrupt enable bit (ERRIE in SPSCR) is also set. MODF and OVRF can generate a receiver/error CPU interrupt request. (See [Figure 17-8](#).) It is not possible to enable only MODF or OVRF to generate a receiver/error CPU interrupt request. However, leaving MODFEN low prevents MODF from being set.

If an end-of-block transmission interrupt was meant to pull the MCU out of wait, having an overflow condition without overflow interrupts enabled causes the MCU to hang in wait mode. If the OVRF is enabled to generate an interrupt, it can pull the MCU out of wait mode instead.

If the CPU SPRF interrupt is enabled and the OVRF interrupt is not, watch for an overflow condition. [Figure 17-6](#) shows how it is possible to miss an overflow.

Serial Peripheral Interface (SPI)

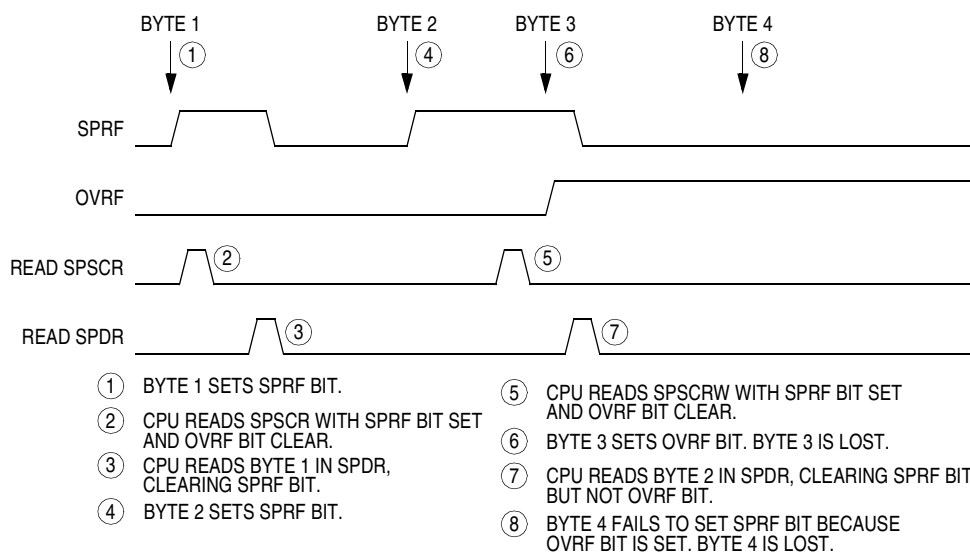

Figure 17-6. Missed Read of Overflow Condition

The first part of [Figure 17-6](#) shows how to read the SPSCR and SPDR to clear the SPRF without problems. However, as illustrated by the second transmission example, the OVRF flag can be set in between the time that SPSCR and SPDR are read.

In this case, an overflow can be easily missed. Since no more SPRF interrupts can be generated until this OVRF is serviced, it will not be obvious that bytes are being lost as more transmissions are completed. To prevent this, either enable the OVRF interrupt or do another read of the SPSCR after the read of the SPDR. This ensures that the OVRF was not set before the SPRF was cleared and that future transmissions will complete with an SPRF interrupt. [Figure 17-7](#) illustrates this process. Generally, to avoid this second SPSCR read, enable the OVRF to the CPU by setting the ERRIE bit (SPSCR).

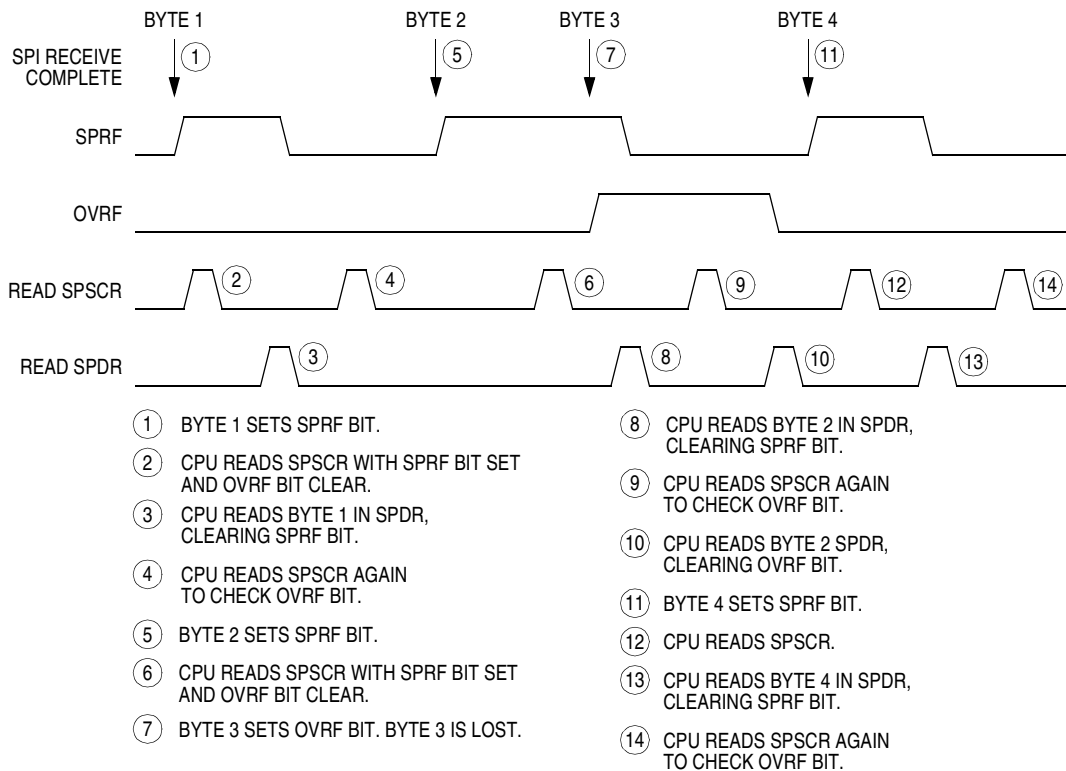

Figure 17-7. Clearing SPRF When OVRF Interrupt Is Not Enabled

17.7.2 Mode Fault Error

For the MODF flag (in SPSCR) to be set, the mode fault error enable bit (MODFEN in SPSCR) must be set. Clearing the MODFEN bit does not clear the MODF flag but does prevent MODF from being set again after MODF is cleared.

MODF generates a receiver/error CPU interrupt request if the error interrupt enable bit (ERRIE in SPSCR) is also set. The SPRF, MODF, and OVRF interrupts share the same CPU interrupt vector. MODF and OVRF can generate a receiver/error CPU interrupt request. (See [Figure 17-8](#)). It is not possible to enable only MODF or OVRF to generate a receiver/error CPU interrupt request. However, leaving MODFEN low prevents MODF from being set.

Serial Peripheral Interface (SPI)

In a master SPI with the mode fault enable bit (MODFEN) set, the mode fault flag (MODF) is set if \overline{SS} goes to logic 0. A mode fault in a master SPI causes the following events to occur:

- If ERRIE = 1, the SPI generates an SPI receiver/error CPU interrupt request.
- The SPE bit is cleared.
- The SPTE bit is set.
- The SPI state counter is cleared.
- The data direction register of the shared I/O port regains control of port drivers.

NOTE: *To prevent bus contention with another master SPI after a mode fault error, clear all data direction register (DDR) bits associated with the SPI shared port pins.*

NOTE: *Setting the MODF flag (SPSCR) does not clear the SPMSTR bit. Reading SPMSTR when MODF = 1 will indicate a MODE fault error occurred in either master mode or slave mode.*

When configured as a slave (SPMSTR = 0), the MODF flag is set if \overline{SS} goes high during a transmission. When CPHA = 0, a transmission begins when \overline{SS} goes low and ends once the incoming SPSCCK returns to its idle level after the shift of the eighth data bit. When CPHA = 1, the transmission begins when the SPSCCK leaves its idle level and \overline{SS} is already low. The transmission continues until the SPSCCK returns to its IDLE level after the shift of the last data bit. (See [Transmission Formats](#) on page 242).

NOTE: *When CPHA = 0, a MODF occurs if a slave is selected (\overline{SS} is at logic 0) and later deselected (\overline{SS} is at logic 1) even if no SPSCCK is sent to that slave. This happens because \overline{SS} at logic 0 indicates the start of the transmission (MISO driven out with the value of MSB) for CPHA = 0. When CPHA = 1, a slave can be selected and then later deselected with no transmission occurring. Therefore, MODF does not occur since a transmission was never begun.*

In a slave SPI (MSTR = 0), the MODF bit generates an SPI receiver/error CPU interrupt request if the ERRIE bit is set. The MODF

bit does not clear the SPE bit or reset the SPI in any way. Software can abort the SPI transmission by toggling the SPE bit of the slave.

NOTE: *A logic 1 voltage on the \overline{SS} pin of a slave SPI puts the MISO pin in a high impedance state. Also, the slave SPI ignores all incoming SPSCCK clocks, even if a transmission has begun.*

To clear the MODF flag, read the SPSCR and then write to the SPCR register. This entire clearing procedure must occur with no MODF condition existing or else the flag will not be cleared.

17.8 Interrupts

Four SPI status flags can be enabled to generate CPU interrupt requests:

Table 17-4. SPI Interrupts

Flag	Request
SPTIE (Transmitter Empty)	SPI Transmitter CPU Interrupt Request (SPTIE = 1)
SPRF (Receiver Full)	SPI Receiver CPU Interrupt Request (SPRIE = 1)
OVRF (Overflow)	SPI Receiver/Error Interrupt Request (SPRIE = 1, ERRIE = 1)
MODF (Mode Fault)	SPI Receiver/Error Interrupt Request (SPRIE = 1, ERRIE = 1, MODFEN = 1)

The SPI transmitter interrupt enable bit (SPTIE) enables the SPTIE flag to generate transmitter CPU interrupt requests.

The SPI receiver interrupt enable bit (SPRIE) enables the SPRF bit to generate receiver CPU interrupt, provided that the SPI is enabled (SPE = 1).

The error interrupt enable bit (ERRIE) enables both the MODF and OVRF flags to generate a receiver/error CPU interrupt request.

The mode fault enable bit (MODFEN) can prevent the MODF flag from being set so that only the OVRF flag is enabled to generate receiver/error CPU interrupt requests.

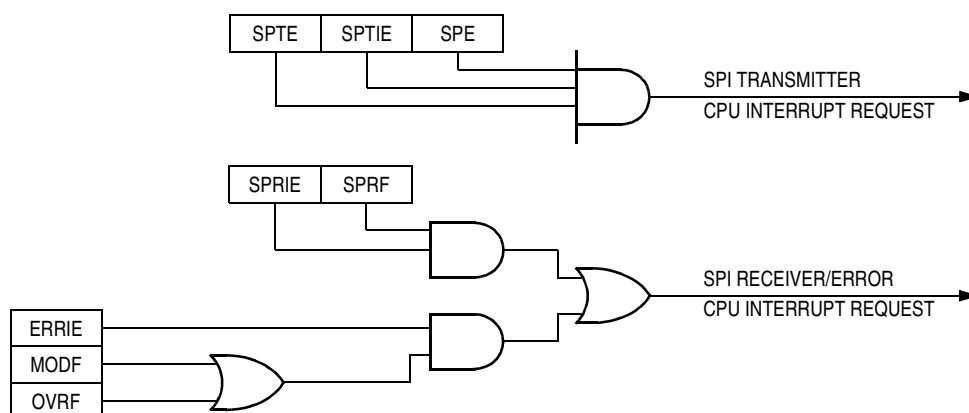

Figure 17-8. SPI Interrupt Request Generation

Two sources in the SPI status and control register can generate CPU interrupt requests:

1. SPI receiver full bit (SPRF) — The SPRF bit becomes set every time a byte transfers from the shift register to the receive data register. If the SPI receiver interrupt enable bit, SPRIE, is also set, SPRF can generate an SPI receiver/error CPU interrupt request.
2. SPI transmitter empty (SPTIE) — The SPTIE bit becomes set every time a byte transfers from the transmit data register to the shift register. If the SPI transmit interrupt enable bit, SPTIE, is also set, SPTIE can generate an SPTIE CPU interrupt request.

17.9 Queuing Transmission Data

The double-buffered transmit data register allows a data byte to be queued and transmitted. For an SPI configured as a master, a queued data byte is transmitted immediately after the previous transmission has completed. The SPI transmitter empty flag (SPTIE in SPSCR) indicates when the transmit data buffer is ready to accept new data. Write to the SPI data register only when the SPTIE bit is high. [Figure 17-9](#) shows the timing associated with doing back-to-back transmissions with the SPI (SPSCK has CPHA:CPOL = 1:0).

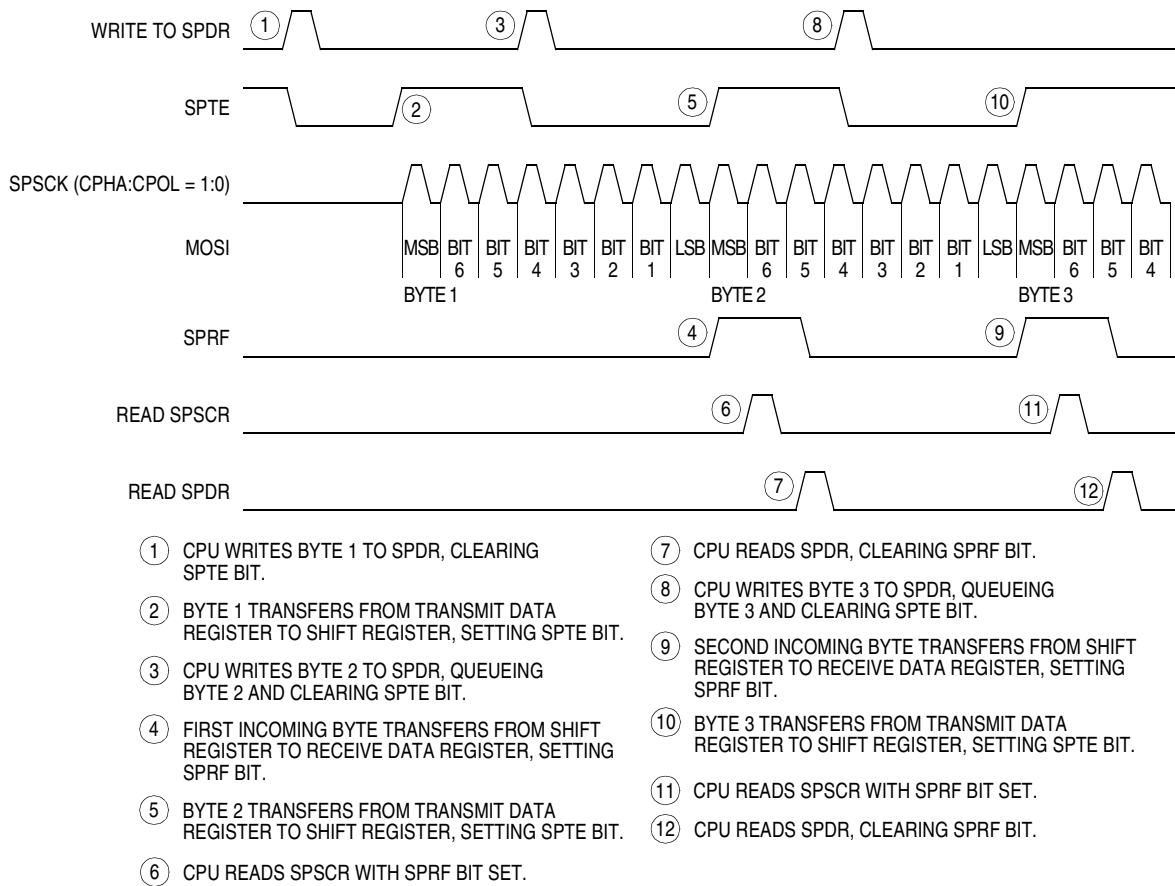

Figure 17-9. SPRF/SPTE CPU Interrupt Timing

For a slave, the transmit data buffer allows back-to-back transmissions to occur without the slave having to time the write of its data between the transmissions. Also, if no new data is written to the data buffer, the last value contained in the shift register will be the next data word transmitted.

17.10 Resetting the SPI

Any system reset completely resets the SPI. Partial reset occurs whenever the SPI enable bit (SPE) is low. Whenever SPE is low, the following occurs:

- The SPTE flag is set.
- Any transmission currently in progress is aborted.
- The shift register is cleared.
- The SPI state counter is cleared, making it ready for a new complete transmission.
- All the SPI port logic is defaulted back to being general-purpose I/O.

The following additional items are reset only by a system reset:

- All control bits in the SPCR register
- All control bits in the SPSCR register (MODFEN, ERRIE, SPR1, and SPR0)
- The status flags SPRF, OVRF, and MODF

By not resetting the control bits when SPE is low, the user can clear SPE between transmissions without having to reset all control bits when SPE is set back to high for the next transmission.

By not resetting the SPRF, OVRF, and MODF flags, the user can still service these interrupts after the SPI has been disabled. The user can disable the SPI by writing 0 to the SPE bit. The SPI also can be disabled by a mode fault occurring in an SPI that was configured as a master with the MODFEN bit set.

17.11 Low-Power Modes

The WAIT and STOP instructions put the MCU in low power-consumption standby modes.

17.11.1 Wait Mode

The SPI module remains active after the execution of a WAIT instruction. In wait mode, the SPI module registers are not accessible by the CPU. Any enabled CPU interrupt request from the SPI module can bring the MCU out of wait mode.

If SPI module functions are not required during wait mode, reduce power consumption by disabling the SPI module before executing the WAIT instruction.

To exit wait mode when an overflow condition occurs, enable the OVRF bit to generate CPU interrupt requests by setting the error interrupt enable bit (ERRIE). (See [Interrupts](#) on page 251).

17.11.2 Stop Mode

The SPI module is inactive after the execution of a STOP instruction. The STOP instruction does not affect register conditions. SPI operation resumes after the MCU exits stop mode. If stop mode is exited by reset, any transfer in progress is aborted and the SPI is reset.

17.12 SPI During Break Interrupts

The system integration module (SIM) controls whether status bits in other modules can be cleared during the break state. The BCFE bit in the SIM break flag control register (SBFCR, \$FE03) enables software to clear status bits during the break state. (See [SIM Break Flag Control Register](#) on page 122).

To allow software to clear status bits during a break interrupt, write a logic 1 to the BCFE bit. If a status bit is cleared during the break state, it remains cleared when the MCU exits the break state.

To protect status bits during the break state, write a logic 0 to the BCFE bit. With BCFE at logic 0 (its default state), software can read and write I/O registers during the break state without affecting status bits. Some status bits have a two-step read/write clearing procedure. If software does the first step on such a bit before the break, the bit cannot change during the break state as long as BCFE is at logic 0. After the break, doing the second step clears the status bit.

Since the SPTE bit cannot be cleared during a break with the BCFE bit cleared, a write to the data register in break mode will not initiate a transmission nor will this data be transferred into the shift register. Therefore, a write to the SPDR in break mode with the BCFE bit cleared has no effect.

17.13 I/O Signals

The SPI module has four I/O pins and shares three of them with a parallel I/O port.

- MISO — Data received
- MOSI — Data transmitted
- SPCK — Serial clock
- \overline{SS} — Slave select
- V_{SS} — Clock ground

The SPI has limited inter-integrated circuit (I²C) capability (requiring software support) as a master in a single-master environment. To communicate with I²C peripherals, MOSI becomes an open-drain output when the SPWOM bit in the SPI control register is set. In I²C communication, the MOSI and MISO pins are connected to a bidirectional pin from the I²C peripheral and through a pullup resistor to V_{DD} .

17.13.1 MISO (Master In/Slave Out)

MISO is one of the two SPI module pins that transmit serial data. In full duplex operation, the MISO pin of the master SPI module is connected to the MISO pin of the slave SPI module. The master SPI simultaneously receives data on its MISO pin and transmits data from its MOSI pin.

Slave output data on the MISO pin is enabled only when the SPI is configured as a slave. The SPI is configured as a slave when its SPMSTR bit is logic 0 and its \overline{SS} pin is at logic 0. To support a multiple-slave system, a logic 1 on the \overline{SS} pin puts the MISO pin in a high-impedance state.

When enabled, the SPI controls data direction of the MISO pin regardless of the state of the data direction register of the shared I/O port.

17.13.2 MOSI (Master Out/Slave In)

MOSI is one of the two SPI module pins that transmit serial data. In full duplex operation, the MOSI pin of the master SPI module is connected to the MOSI pin of the slave SPI module. The master SPI simultaneously transmits data from its MOSI pin and receives data on its MISO pin.

When enabled, the SPI controls data direction of the MOSI pin regardless of the state of the data direction register of the shared I/O port.

17.13.3 SPSCCK (Serial Clock)

The serial clock synchronizes data transmission between master and slave devices. In a master MCU, the SPSCCK pin is the clock output. In a slave MCU, the SPSCCK pin is the clock input. In full duplex operation, the master and slave MCUs exchange a byte of data in eight serial clock cycles.

When enabled, the SPI controls data direction of the SPSCCK pin regardless of the state of the data direction register of the shared I/O port.

17.13.4 \overline{SS} (Slave Select)

The \overline{SS} pin has various functions depending on the current state of the SPI. For an SPI configured as a slave, the \overline{SS} is used to select a slave. For $CPHA = 0$, the \overline{SS} is used to define the start of a transmission. (See **Transmission Formats**.) Since it is used to indicate the start of a transmission, the \overline{SS} must be toggled high and low between each byte transmitted for the $CPHA = 0$ format. However, it can remain low throughout the transmission for the $CPHA = 1$ format. See [Figure 17-10](#).

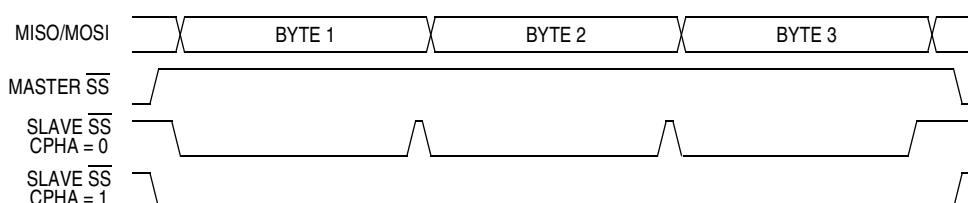

Figure 17-10. CPHA/ \overline{SS} Timing

When an SPI is configured as a slave, the \overline{SS} pin is always configured as an input. It cannot be used as a general-purpose I/O regardless of the state of the MODFEN control bit. However, the MODFEN bit can still prevent the state of the \overline{SS} from creating a MODF error. (See [SPI Status and Control Register](#) on page 262).

NOTE: *A logic 1 voltage on the \overline{SS} pin of a slave SPI puts the MISO pin in a high-impedance state. The slave SPI ignores all incoming SPSCK clocks, even if a transmission already has begun.*

When an SPI is configured as a master, the \overline{SS} input can be used in conjunction with the MODF flag to prevent multiple masters from driving MOSI and SPSCK. (See [Mode Fault Error](#) on page 249). For the state of the \overline{SS} pin to set the MODF flag, the MODFEN bit in the SPSCK \overline{SS} register must be set. If the MODFEN bit is low for an SPI master, the \overline{SS} pin can be used as a general-purpose I/O under the control of the data direction register of the shared I/O port. With MODFEN high, it is an input-only pin to the SPI regardless of the state of the data direction register of the shared I/O port.

The CPU can always read the state of the \overline{SS} pin by configuring the appropriate pin as an input and reading the data register. (See [Table 17-5](#)).

Table 17-5. SPI Configuration

SPE	SPMSTR	MODFEN	SPI Configuration	State of \overline{SS} Logic
0	X	X	Not Enabled	General-Purpose I/O; \overline{SS} Ignored by SPI
1	0	X	Slave	Input-Only to SPI
1	1	0	Master without MODF	General-Purpose I/O; \overline{SS} Ignored by SPI
1	1	1	Master with MODF	Input-Only to SPI

X = don't care

17.13.5 V_{SS} (Clock Ground)

V_{SS} is the ground return for the serial clock pin, SPSCCK, and the ground for the port output buffers. To reduce the ground return path loop and minimize radio frequency (RF) emissions, connect the ground pin of the slave to the V_{SS} pin.

17.14 I/O Registers

Three registers control and monitor SPI operation:

- SPI control register (SPCR \$0010)
- SPI status and control register (SPSCR \$0011)
- SPI data register (SPDR \$0012)

Serial Peripheral Interface (SPI)

17.14.1 SPI Control Register

The SPI control register:

- Enables SPI module interrupt requests
- Selects CPU interrupt requests
- Configures the SPI module as master or slave
- Selects serial clock polarity and phase
- Configures the SPSCCK, MOSI, and MISO pins as open-drain outputs
- Enables the SPI module

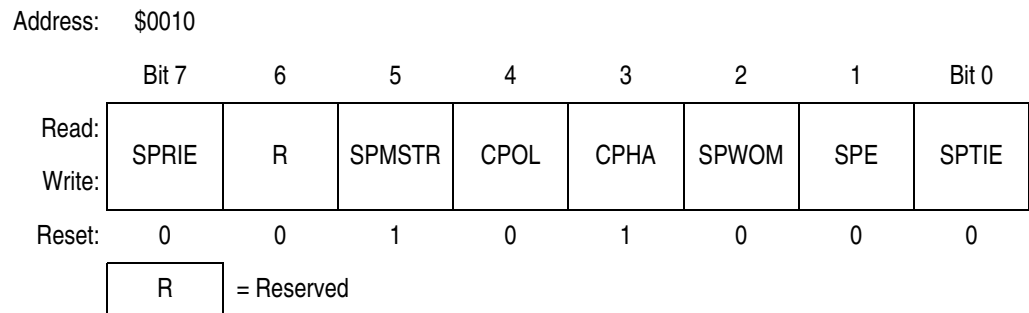

Figure 17-11. SPI Control Register (SPCR)

SPRIE — SPI Receiver Interrupt Enable Bit

This read/write bit enables CPU interrupt requests generated by the SPRF bit. The SPRF bit is set when a byte transfers from the shift register to the receive data register. Reset clears the SPRIE bit.

- 1 = SPRF CPU interrupt requests enabled
- 0 = SPRF CPU interrupt requests disabled

SPMSTR — SPI Master Bit

This read/write bit selects master mode operation or slave mode operation. Reset sets the SPMSTR bit.

- 1 = Master mode
- 0 = Slave mode

CPOL — Clock Polarity Bit

This read/write bit determines the logic state of the SPSCCK pin between transmissions. (See [Figure 17-3](#) and [Figure 17-4](#).) To transmit data between SPI modules, the SPI modules must have identical CPOL bits. Reset clears the CPOL bit.

CPHA — Clock Phase Bit

This read/write bit controls the timing relationship between the serial clock and SPI data. (See [Figure 17-3](#) and [Figure 17-4](#).) To transmit data between SPI modules, the SPI modules must have identical CPHA bits. When CPHA = 0, the \overline{SS} pin of the slave SPI module must be set to logic 1 between bytes. (See [Figure 17-10](#)). Reset sets the CPHA bit.

When CPHA = 0 for a slave, the falling edge of \overline{SS} indicates the beginning of the transmission. This causes the SPI to leave its idle state and begin driving the MISO pin with the MSB of its data. Once the transmission begins, no new data is allowed into the shift register from the data register. Therefore, the slave data register must be loaded with the desired transmit data before the falling edge of \overline{SS} . Any data written after the falling edge is stored in the data register and transferred to the shift register at the current transmission.

When CPHA = 1 for a slave, the first edge of the SPSCCK indicates the beginning of the transmission. The same applies when \overline{SS} is high for a slave. The MISO pin is held in a high-impedance state, and the incoming SPSCCK is ignored. In certain cases, it may also cause the MODF flag to be set. (See [Mode Fault Error](#) on page 249). A logic 1 on the \overline{SS} pin does not in any way affect the state of the SPI state machine.

SPWOM — SPI Wired-OR Mode Bit

This read/write bit disables the pullup devices on pins SPSCCK, MOSI, and MISO so that those pins become open-drain outputs.

1 = Wired-OR SPSCCK, MOSI, and MISO pins

0 = Normal push-pull SPSCCK, MOSI, and MISO pins

SPE — SPI Enable Bit

This read/write bit enables the SPI module. Clearing SPE causes a partial reset of the SPI (see [Resetting the SPI](#) on page 254). Reset clears the SPE bit.

1 = SPI module enabled

0 = SPI module disabled

SPTIE — SPI Transmit Interrupt Enable Bit

This read/write bit enables CPU interrupt requests generated by the SPTIE bit. SPTIE is set when a byte transfers from the transmit data register to the shift register. Reset clears the SPTIE bit.

1 = SPTIE CPU interrupt requests enabled

0 = SPTIE CPU interrupt requests disabled

17.14.2 SPI Status and Control Register

The SPI status and control register contains flags to signal the following conditions:

- Receive data register full
- Failure to clear SPRF bit before next byte is received (overflow error)
- Inconsistent logic level on \overline{SS} pin (mode fault error)
- Transmit data register empty

The SPI status and control register also contains bits that perform these functions:

- Enable error interrupts
- Enable mode fault error detection
- Select master SPI baud rate

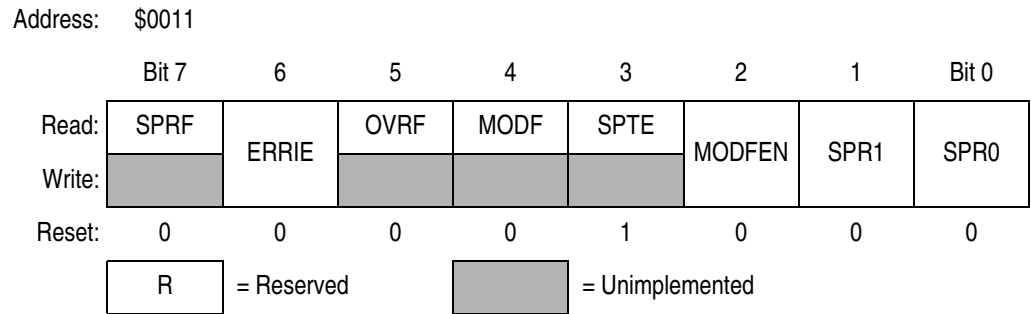

Figure 17-12. SPI Status and Control Register (SPSCR)

SPRF — SPI Receiver Full Bit

This clearable, read-only flag is set each time a byte transfers from the shift register to the receive data register. SPRF generates a CPU interrupt request if the SPRIE bit in the SPI control register is set also. During an SPRF CPU interrupt, the CPU clears SPRF by reading the SPI status and control register with SPRF set and then reading the SPI data register. Any read of the SPI data register clears the SPRF bit.

Reset clears the SPRF bit.

- 1 = Receive data register full
- 0 = Receive data register not full

ERRIE — Error Interrupt Enable Bit

This read-only bit enables the MODF and OVRF flags to generate CPU interrupt requests. Reset clears the ERRIE bit.

- 1 = MODF and OVRF can generate CPU interrupt requests
- 0 = MODF and OVRF cannot generate CPU interrupt requests

OVRF — Overflow Bit

This clearable, read-only flag is set if software does not read the byte in the receive data register before the next byte enters the shift register. In an overflow condition, the byte already in the receive data register is unaffected, and the byte that shifted in last is lost. Clear the OVRF bit by reading the SPI status and control register with OVRF set and then reading the SPI data register. Reset clears the OVRF flag.

- 1 = Overflow
- 0 = No overflow

MODF — Mode Fault Bit

This clearable, read-only flag is set in a slave SPI if the \overline{SS} pin goes high during a transmission. In a master SPI, the MODF flag is set if the \overline{SS} pin goes low at any time. Clear the MODF bit by reading the SPI status and control register with MODF set and then writing to the SPI data register. Reset clears the MODF bit.

1 = \overline{SS} pin at inappropriate logic level

0 = \overline{SS} pin at appropriate logic level

SPTE — SPI Transmitter Empty Bit

This clearable, read-only flag is set each time the transmit data register transfers a byte into the shift register. SPTE generates an SPTIE CPU interrupt request if the SPTIE bit in the SPI control register is set also.

NOTE: *Do not write to the SPI data register unless the SPTE bit is high.*

For an idle master or idle slave that has no data loaded into its transmit buffer, the SPTE will be set again within two bus cycles since the transmit buffer empties into the shift register. This allows the user to queue up a 16-bit value to send. For an already active slave, the load of the shift register cannot occur until the transmission is completed. This implies that a back-to-back write to the transmit data register is not possible. The SPTE indicates when the next write can occur.

Reset sets the SPTE bit.

1 = Transmit data register empty

0 = Transmit data register not empty

MODFEN — Mode Fault Enable Bit

This read/write bit, when set to 1, allows the MODF flag to be set. If the MODF flag is set, clearing the MODFEN does not clear the MODF flag. If the SPI is enabled as a master and the MODFEN bit is low, then the \overline{SS} pin is available as a general-purpose I/O.

If the MODFEN bit is set, then this pin is not available as a general purpose I/O. When the SPI is enabled as a slave, the \overline{SS} pin is not available as a general-purpose I/O regardless of the value of MODFEN. (See **SS (Slave Select)** on page 258).

If the MODFEN bit is low, the level of the \overline{SS} pin does not affect the operation of an enabled SPI configured as a master. For an enabled SPI configured as a slave, having MODFEN low only prevents the MODF flag from being set. It does not affect any other part of SPI operation. (See [Mode Fault Error](#) on page 249).

SPR1 and SPR0 — SPI Baud Rate Select Bits

In master mode, these read/write bits select one of four baud rates as shown in [Table 17-6](#). SPR1 and SPR0 have no effect in slave mode. Reset clears SPR1 and SPR0.

Table 17-6. SPI Master Baud Rate Selection

SPR1:SPR0	Baud Rate Divisor (BD)
00	2
01	8
10	32
11	128

Use this formula to calculate the SPI baud rate:

$$\text{Baud rate} = \frac{\text{CGMOUT}}{2 \times \text{BD}}$$

where:

CGMOUT = base clock output of the clock generator module (CGM), see [Clock Generator Module \(CGM\)](#) on page 123.

BD = baud rate divisor

17.14.3 SPI Data Register

The SPI data register is the read/write buffer for the receive data register and the transmit data register. Writing to the SPI data register writes data into the transmit data register. Reading the SPI data register reads data from the receive data register. The transmit data and receive data registers are separate buffers that can contain different values. See [Figure 17-1](#)

Address: \$0012

	Bit 7	6	5	4	3	2	1	Bit 0
Read:	R7	R6	R5	R4	R3	R2	R1	R0
Write:	T7	T6	T5	T4	T3	T2	T1	T0

Reset: Indeterminate after Reset

Figure 17-13. SPI Data Register (SPDR)

R7–R0/T7–T0 — Receive/Transmit Data Bits

NOTE: Do not use read-modify-write instructions on the SPI data register since the buffer read is not the same as the buffer written.

Section 18. Timer Interface Module B (TIMB)

18.1 Contents

18.2	Introduction	268
18.3	Features	268
18.4	Functional Description	271
18.4.1	TIMB Counter Prescaler	271
18.4.2	Input Capture	271
18.4.3	Output Compare	273
18.4.3.1	Unbuffered Output Compare	273
18.4.3.2	Buffered Output Compare	274
18.4.4	Pulse Width Modulation (PWM)	274
18.4.4.1	Unbuffered PWM Signal Generation	275
18.4.4.2	Buffered PWM Signal Generation	276
18.4.4.3	PWM Initialization	277
18.5	Interrupts	278
18.6	Low-Power Modes	279
18.6.1	Wait Mode	279
18.6.2	Stop Mode	279
18.7	TIMB During Break Interrupts	279
18.8	I/O Signals	280
18.8.1	TIMB Clock Pin (PTD4/ATD12/TBCLK)	280
18.8.2	TIMB Channel I/O Pins (PTF5/TBCH1–PTF4/TBCH0)	280
18.9	I/O Registers	281
18.9.1	TIMB Status and Control Register	281
18.9.2	TIMB Counter Registers	283
18.9.3	TIMB Counter Modulo Registers	285
18.9.4	TIMB Channel Status and Control Registers	286
18.9.5	TIMB Channel Registers	290

18.2 Introduction

This section describes the timer interface module (TIMB). The TIMB is a 2-channel timer that provides a timing reference with input capture, output compare and pulse width modulation functions. [Figure 18-1](#) is a block diagram of the TIMB.

The TIMB module is feature of the MC68HC908AZ60A only.

For further information regarding timers on M68HC08 family devices, please consult the HC08 Timer Reference Manual, TIM08RM/AD.

18.3 Features

Features of the TIMB include:

- Two Input Capture/Output Compare Channels
 - Rising-Edge, Falling-Edge or Any-Edge Input Capture Trigger
 - Set, Clear or Toggle Output Compare Action
- Buffered and Unbuffered Pulse Width Modulation (PWM) Signal Generation
- Programmable TIMB Clock Input
 - 7 Frequency Internal Bus Clock Prescaler Selection
 - External TIMB Clock Input (4 MHz Maximum Frequency)
- Free-Running or Modulo Up-Count Operation
- Toggle Any Channel Pin on Overflow
- TIMB Counter Stop and Reset Bits

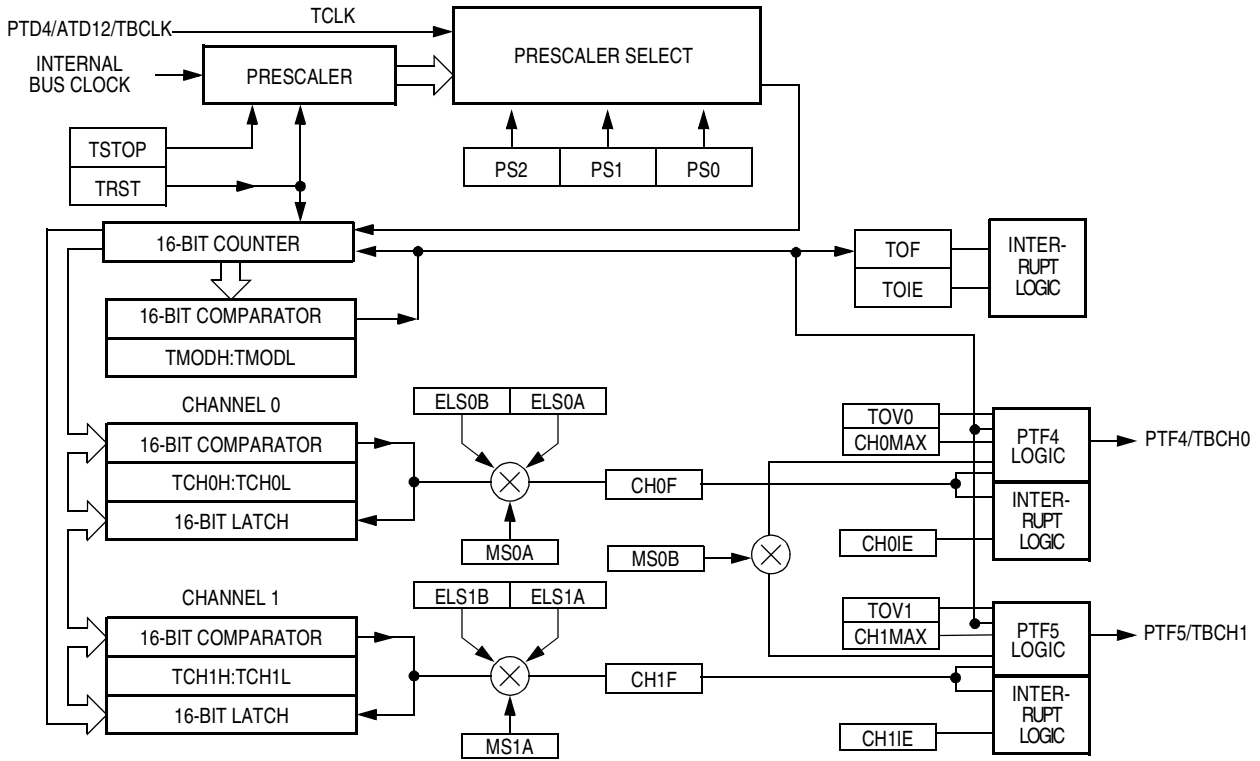

Figure 18-1. TIMB Block Diagram

Figure 18-2. TIMB I/O Register Summary

Addr.	Register Name	Bit 7	6	5	4	3	2	1	Bit 0
\$0040	TIMB Status/Control Register (TBSC)	TOF	TOIE	TSTOP	TRST	0	PS2	PS1	PS0
\$0041	TIMB Counter Register High (TBCNTH)	Bit 15	14	13	12	11	10	9	Bit 8
\$0042	TIMB Counter Register Low (TBCNTL)	Bit 7	6	5	4	3	2	1	Bit 0
\$0043	TIMB Counter Modulo Reg. High (TBMODH)	Bit 15	14	13	12	11	10	9	Bit 8
\$0044	TIMB Counter Modulo Reg. Low (TBMODL)	Bit 7	6	5	4	3	2	1	Bit 0
\$0045	TIMB Ch. 0 Status/Control Register (TBSC0)	CH0F	CH0IE	MS0B	MS0A	ELS0B	ELS0A	TOV0	CH0MAX
\$0046	TIMB Ch. 0 Register High (TBCH0H)	Bit 15	14	13	12	11	10	9	Bit 8
\$0047	TIMB Ch. 0 Register Low (TBCH0L)	Bit 7	6	5	4	3	2	1	Bit 0
\$0048	TIMB Ch. 1 Status/Control Register (TBSC1)	CH1F	CH1IE	0	MS1A	ELS1B	ELS1A	TOV1	CH1MAX
\$0049	TIMB Ch. 1 Register High (TBCH1H)	Bit 15	14	13	12	11	10	9	Bit 8
\$004A	TIMB Ch. 1 Register Low (TBCH1L)	Bit 7	6	5	4	3	2	1	Bit 0

R = Reserved

18.4 Functional Description

Figure 18-1 shows the TIMB structure. The central component of the TIMB is the 16-bit TIMB counter that can operate as a free-running counter or a modulo up-counter. The TIMB counter provides the timing reference for the input capture and output compare functions. The TIMB counter modulo registers, TBMODH–TBMODL, control the modulo value of the TIMB counter. Software can read the TIMB counter value at any time without affecting the counting sequence.

The two TIMB channels are programmable independently as input capture or output compare channels.

18.4.1 TIMB Counter Prescaler

The TIMB clock source can be one of the seven prescaler outputs or the TIMB clock pin, PTD4/ATD12/TBCLK. The prescaler generates seven clock rates from the internal bus clock. The prescaler select bits, PS[2:0], in the TIMB status and control register select the TIMB clock source.

18.4.2 Input Capture

An input capture function has three basic parts: edge select logic, an input capture latch and a 16-bit counter. Two 8-bit registers, which make up the 16-bit input capture register, are used to latch the value of the free-running counter after the corresponding input capture edge detector senses a defined transition. The polarity of the active edge is programmable. The level transition which triggers the counter transfer is defined by the corresponding input edge bits (ELSxB and ELSxA in TBSC0 through TBSC1 control registers with x referring to the active channel number). When an active edge occurs on the pin of an input capture channel, the TIMB latches the contents of the TIMB counter into the TIMB channel registers, TBCHxH–TBCHxL. Input captures can generate TIMB CPU interrupt requests. Software can determine that an input capture event has occurred by enabling input capture interrupts or by polling the status flag bit.

The free-running counter contents are transferred to the TIMB channel register (TBCHxH–TBCHxL, see [TIMB Channel Registers](#) on page 290) on each proper signal transition regardless of whether the TIMB channel flag (CH0F–CH1F in TBSC0–TBSC1 registers) is set or clear. When the status flag is set, a CPU interrupt is generated if enabled. The value of the count latched or “captured” is the time of the event. Because this value is stored in the input capture register 2 bus cycles after the actual event occurs, user software can respond to this event at a later time and determine the actual time of the event. However, this must be done prior to another input capture on the same pin; otherwise, the previous time value will be lost.

By recording the times for successive edges on an incoming signal, software can determine the period and/or pulse width of the signal. To measure a period, two successive edges of the same polarity are captured. To measure a pulse width, two alternate polarity edges are captured. Software should track the overflows at the 16-bit module counter to extend its range.

Another use for the input capture function is to establish a time reference. In this case, an input capture function is used in conjunction with an output compare function. For example, to activate an output signal a specified number of clock cycles after detecting an input event (edge), use the input capture function to record the time at which the edge occurred. A number corresponding to the desired delay is added to this captured value and stored to an output compare register (see [TIMB Channel Registers](#) on page 290). Because both input captures and output compares are referenced to the same 16-bit modulo counter, the delay can be controlled to the resolution of the counter independent of software latencies.

Reset does not affect the contents of the input capture channel register (TBCHxH–TBCHxL).

18.4.3 Output Compare

With the output compare function, the TIMB can generate a periodic pulse with a programmable polarity, duration and frequency. When the counter reaches the value in the registers of an output compare channel, the TIMB can set, clear or toggle the channel pin. Output compares can generate TIMB CPU interrupt requests.

18.4.3.1 Unbuffered Output Compare

Any output compare channel can generate unbuffered output compare pulses as described in [Output Compare](#) on page 273. The pulses are unbuffered because changing the output compare value requires writing the new value over the old value currently in the TIMB channel registers.

An unsynchronized write to the TIMB channel registers to change an output compare value could cause incorrect operation for up to two counter overflow periods. For example, writing a new value before the counter reaches the old value but after the counter reaches the new value prevents any compare during that counter overflow period. Also, using a TIMB overflow interrupt routine to write a new, smaller output compare value may cause the compare to be missed. The TIMB may pass the new value before it is written.

Use the following methods to synchronize unbuffered changes in the output compare value on channel x:

- When changing to a smaller value, enable channel x output compare interrupts and write the new value in the output compare interrupt routine. The output compare interrupt occurs at the end of the current output compare pulse. The interrupt routine has until the end of the counter overflow period to write the new value.
- When changing to a larger output compare value, enable TIMB overflow interrupts and write the new value in the TIMB overflow interrupt routine. The TIMB overflow interrupt occurs at the end of the current counter overflow period. Writing a larger value in an output compare interrupt routine (at the end of the current pulse) could cause two output compares to occur in the same counter overflow period.

18.4.3.2 Buffered Output Compare

Channels 0 and 1 can be linked to form a buffered output compare channel whose output appears on the PTF4/TBCH0 pin. The TIMB channel registers of the linked pair alternately control the output.

Setting the MS0B bit in TIMB channel 0 status and control register (TBSC0) links channel 0 and channel 1. The output compare value in the TIMB channel 0 registers initially controls the output on the PTF4/TBCH0 pin. Writing to the TIMB channel 1 registers enables the TIMB channel 1 registers to synchronously control the output after the TIMB overflows. At each subsequent overflow, the TIMB channel registers (0 or 1) that control the output are the ones written to last. TBSC0 controls and monitors the buffered output compare function and TIMB channel 1 status and control register (TBSC1) is unused. While the MS0B bit is set, the channel 1 pin, PTF5/TBCH1, is available as a general-purpose I/O pin.

NOTE: *In buffered output compare operation, do not write new output compare values to the currently active channel registers. User software should track the currently active channel to prevent writing a new value to the active channel. Writing to the active channel registers is the same as generating unbuffered output compares.*

18.4.4 Pulse Width Modulation (PWM)

By using the toggle-on-overflow feature with an output compare channel, the TIMB can generate a PWM signal. The value in the TIMB counter modulo registers determines the period of the PWM signal. The channel pin toggles when the counter reaches the value in the TIMB counter modulo registers. The time between overflows is the period of the PWM signal.

As [Figure 18-3](#) shows, the output compare value in the TIMB channel registers determines the pulse width of the PWM signal. The time between overflow and output compare is the pulse width. Program the TIMB to clear the channel pin on output compare if the state of the PWM pulse is logic 1. Program the TIMB to set the pin if the state of the PWM pulse is logic 0.

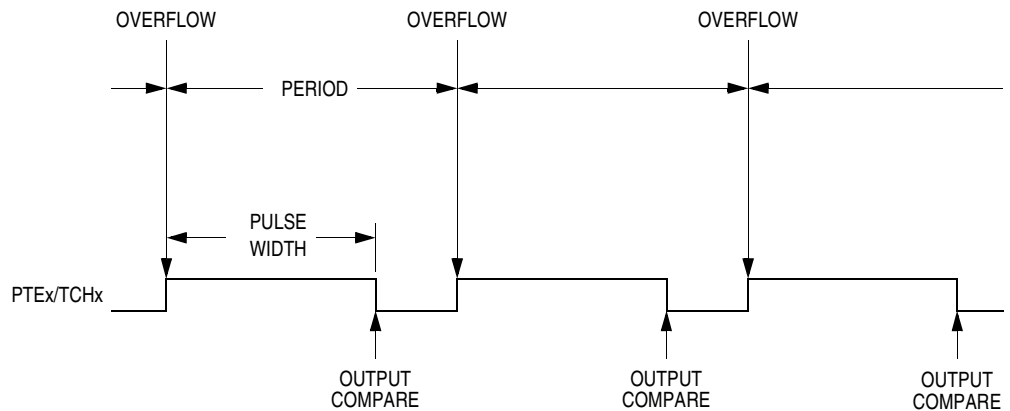

Figure 18-3. PWM Period and Pulse Width

The value in the TIMB counter modulo registers and the selected prescaler output determines the frequency of the PWM output. The frequency of an 8-bit PWM signal is variable in 256 increments. Writing \$00FF (255) to the TIMB counter modulo registers produces a PWM period of 256 times the internal bus clock period if the prescaler select value is \$000 (see [TIMB Status and Control Register](#)).

The value in the TIMB channel registers determines the pulse width of the PWM output. The pulse width of an 8-bit PWM signal is variable in 256 increments. Writing \$0080 (128) to the TIMB channel registers produces a duty cycle of 128/256 or 50%.

18.4.4.1 Unbuffered PWM Signal Generation

Any output compare channel can generate unbuffered PWM pulses as described in [Pulse Width Modulation \(PWM\)](#) on page 274. The pulses are unbuffered because changing the pulse width requires writing the new pulse width value over the value currently in the TIMB channel registers.

An unsynchronized write to the TIMB channel registers to change a pulse width value could cause incorrect operation for up to two PWM periods. For example, writing a new value before the counter reaches the old value but after the counter reaches the new value prevents any compare during that PWM period. Also, using a TIMB overflow interrupt routine to write a new, smaller pulse width value may cause the compare

to be missed. The TIMB may pass the new value before it is written to the TIMB channel registers.

Use the following methods to synchronize unbuffered changes in the PWM pulse width on channel x:

- When changing to a shorter pulse width, enable channel x output compare interrupts and write the new value in the output compare interrupt routine. The output compare interrupt occurs at the end of the current pulse. The interrupt routine has until the end of the PWM period to write the new value.
- When changing to a longer pulse width, enable TIMB overflow interrupts and write the new value in the TIMB overflow interrupt routine. The TIMB overflow interrupt occurs at the end of the current PWM period. Writing a larger value in an output compare interrupt routine (at the end of the current pulse) could cause two output compares to occur in the same PWM period.

NOTE: *In PWM signal generation, do not program the PWM channel to toggle on output compare. Toggling on output compare prevents reliable 0% duty cycle generation and removes the ability of the channel to self-correct in the event of software error or noise. Toggling on output compare also can cause incorrect PWM signal generation when changing the PWM pulse width to a new, much larger value.*

18.4.4.2 Buffered PWM Signal Generation

Channels 0 and 1 can be linked to form a buffered PWM channel whose output appears on the PTF4/TBCH0 pin. The TIMB channel registers of the linked pair alternately control the pulse width of the output.

Setting the MS0B bit in TIMB channel 0 status and control register (TBSC0) links channel 0 and channel 1. The TIMB channel 0 registers initially control the pulse width on the PTF4/TBCH0 pin. Writing to the TIMB channel 1 registers enables the TIMB channel 1 registers to synchronously control the pulse width at the beginning of the next PWM period. At each subsequent overflow, the TIMB channel registers (0 or 1) that control the pulse width are the ones written to last. TBSC0 controls and monitors the buffered PWM function, and TIMB channel 1

status and control register (TBSC1) is unused. While the MS0B bit is set, the channel 1 pin, PTF5/TBCH1, is available as a general-purpose I/O pin.

NOTE: *In buffered PWM signal generation, do not write new pulse width values to the currently active channel registers. User software should track the currently active channel to prevent writing a new value to the active channel. Writing to the active channel registers is the same as generating unbuffered PWM signals.*

18.4.4.3 PWM Initialization

To ensure correct operation when generating unbuffered or buffered PWM signals, use the following initialization procedure:

1. In the TIMB status and control register (TBSC):
 - a. Stop the TIMB counter by setting the TIMB stop bit, TSTOP.
 - b. Reset the TIMB counter and prescaler by setting the TIMB reset bit, TRST.
2. In the TIMB counter modulo registers (TBMODH–TBMODL) write the value for the required PWM period.
3. In the TIMB channel x registers (TBCHxH–TBCHxL) write the value for the required pulse width.
4. In TIMB channel x status and control register (TBSCx):
 - a. Write 0:1 (for unbuffered output compare or PWM signals) or 1:0 (for buffered output compare or PWM signals) to the mode select bits, MSxB–MSxA (see [Table 18-2](#)).
 - b. Write 1 to the toggle-on-overflow bit, TOVx.
 - c. Write 1:0 (to clear output on compare) or 1:1 (to set output on compare) to the edge/level select bits, ELSxB–ELSxA. The output action on compare must force the output to the complement of the pulse width level (see [Table 18-2](#)).

NOTE: *In PWM signal generation, do not program the PWM channel to toggle on output compare. Toggling on output compare prevents reliable 0% duty cycle generation and removes the ability of the channel to self-correct in the event of software error or noise. Toggling on output*

compare can also cause incorrect PWM signal generation when changing the PWM pulse width to a new, much larger value.

5. In the TIMB status control register (TBSC) clear the TIMB stop bit, TSTOP.

Setting MS0B links channels 0 and 1 and configures them for buffered PWM operation. The TIMB channel 0 registers (TBCH0H–TBCH0L) initially control the buffered PWM output. TIMB status control register 0 (TBSC0) controls and monitors the PWM signal from the linked channels. MS0B takes priority over MS0A.

Clearing the toggle-on-overflow bit, TOVx, inhibits output toggles on TIMB overflows. Subsequent output compares try to force the output to a state it is already in and have no effect. The result is a 0% duty cycle output.

Setting the channel x maximum duty cycle bit (CHxMAX) and setting the TOVx bit generates a 100% duty cycle output (see [TIMB Channel Status and Control Registers](#) on page 286).

18.5 Interrupts

The following TIMB sources can generate interrupt requests:

- TIMB overflow flag (TOF) — The TOF bit is set when the TIMB counter value reaches the modulo value programmed in the TIMB counter modulo registers. The TIMB overflow interrupt enable bit, TOIE, enables TIMB overflow CPU interrupt requests. TOF and TOIE are in the TIMB status and control register.
- TIMB channel flags (CH1F–CH0F) — The CHxF bit is set when an input capture or output compare occurs on channel x. Channel x TIMB CPU interrupt requests are controlled by the channel x interrupt enable bit, CHxIE.

18.6 Low-Power Modes

The WAIT and STOP instructions put the MCU in low power-consumption standby modes.

18.6.1 Wait Mode

The TIMB remains active after the execution of a WAIT instruction. In wait mode, the TIMB registers are not accessible by the CPU. Any enabled CPU interrupt request from the TIMB can bring the MCU out of wait mode.

If TIMB functions are not required during wait mode, reduce power consumption by stopping the TIMB before executing the WAIT instruction.

18.6.2 Stop Mode

The TIMB is inactive after the execution of a STOP instruction. The STOP instruction does not affect register conditions or the state of the TIMB counter. TIMB operation resumes when the MCU exits stop mode.

18.7 TIMB During Break Interrupts

A break interrupt stops the TIMB counter and inhibits input captures.

The system integration module (SIM) controls whether status bits in other modules can be cleared during the break state. The BCFE bit in the SIM break flag control register (SBFCR) enables software to clear status bits during the break state (see [SIM Break Flag Control Register](#) on page 122).

To allow software to clear status bits during a break interrupt, write a logic 1 to the BCFE bit. If a status bit is cleared during the break state, it remains cleared when the MCU exits the break state.

To protect status bits during the break state, write a logic 0 to the BCFE bit. With BCFE at logic 0 (its default state), software can read and write

I/O registers during the break state without affecting status bits. Some status bits have a 2-step read/write clearing procedure. If software does the first step on such a bit before the break, the bit cannot change during the break state as long as BCFE is at logic 0. After the break, doing the second step clears the status bit.

18.8 I/O Signals

Port D shares one of its pins with the TIMB. Port F shares two of its pins with the TIMB. PTD4/ATD12/TBCLK is an external clock input to the TIMB prescaler. The two TIMB channel I/O pins are PTF4/TBCH0 and PTF5/TBCH1.

18.8.1 TIMB Clock Pin (PTD4/ATD12/TBCLK)

PTD4/ATD12/TBCLK is an external clock input that can be the clock source for the TIMB counter instead of the prescaled internal bus clock. Select the PTD4/ATD12/TBCLK input by writing logic 1s to the three prescaler select bits, PS[2:0] (see [TIMB Status and Control Register](#)). The minimum TCLK pulse width, $TCLK_{LMIN}$ or $TCLK_{HMIN}$, is:

$$\frac{1}{\text{bus frequency}} + t_{SU}$$

The maximum TCLK frequency is the least: 4 MHz or bus frequency \div 2.

PTD4/ATD12/TBCLK is available as a general-purpose I/O pin or ADC channel when not used as the TIMB clock input. When the PTD4/ATD12/TBCLK pin is the TIMB clock input, it is an input regardless of the state of the DDRD4 bit in data direction register D.

18.8.2 TIMB Channel I/O Pins (PTF5/TBCH1–PTF4/TBCH0)

Each channel I/O pin is programmable independently as an input capture pin or an output compare pin. PTF4/TBCH0 and PTF5/TBCH1 can be configured as buffered output compare or buffered PWM pins.

18.9 I/O Registers

These I/O registers control and monitor TIMB operation:

- TIMB status and control register (TBSC)
- TIMB control registers (TBCNTH–TBCNTL)
- TIMB counter modulo registers (TBMODH–TBMODL)
- TIMB channel status and control registers (TBSC0 and TBSC1)
- TIMB channel registers (TBCH0H–TBCH0L, TBCH1H–TBCH1L)

18.9.1 TIMB Status and Control Register

The TIMB status and control register:

- Enables TIMB overflow interrupts
- Flags TIMB overflows
- Stops the TIMB counter
- Resets the TIMB counter
- Prescales the TIMB counter clock

Address: \$0040

	Bit 7	6	5	4	3	2	1	Bit 0
Read:	TOF	TOIE	TSTOP	0	0	PS2	PS1	PS0
Write:	0			TRST	R			
Reset:	0	0	1	0	0	0	0	0

R = Reserved

Figure 18-4. TIMB Status and Control Register (TBSC)

TOF — TIMB Overflow Flag Bit

This read/write flag is set when the TIMB counter reaches the modulo value programmed in the TIMB counter modulo registers. Clear TOF by reading the TIMB status and control register when TOF is set and then writing a logic 0 to TOF. If another TIMB overflow occurs before

the clearing sequence is complete, then writing logic 0 to TOF has no effect. Therefore, a TOF interrupt request cannot be lost due to inadvertent clearing of TOF. Reset clears the TOF bit. Writing a logic 1 to TOF has no effect.

1 = TIMB counter has reached modulo value

0 = TIMB counter has not reached modulo value

TOIE — TIMB Overflow Interrupt Enable Bit

This read/write bit enables TIMB overflow interrupts when the TOF bit becomes set. Reset clears the TOIE bit.

1 = TIMB overflow interrupts enabled

0 = TIMB overflow interrupts disabled

TSTOP — TIMB Stop Bit

This read/write bit stops the TIMB counter. Counting resumes when TSTOP is cleared. Reset sets the TSTOP bit, stopping the TIMB counter until software clears the TSTOP bit.

1 = TIMB counter stopped

0 = TIMB counter active

NOTE: *Do not set the TSTOP bit before entering wait mode if the TIMB is required to exit wait mode. Also, when the TSTOP bit is set and the timer is configured for input capture operation, input captures are inhibited until TSTOP is cleared.*

TRST — TIMB Reset Bit

Setting this write-only bit resets the TIMB counter and the TIMB prescaler. Setting TRST has no effect on any other registers. Counting resumes from \$0000. TRST is cleared automatically after the TIMB counter is reset and always reads as logic 0. Reset clears the TRST bit.

1 = Prescaler and TIMB counter cleared

0 = No effect

NOTE: *Setting the TSTOP and TRST bits simultaneously stops the TIMB counter at a value of \$0000.*

PS[2:0] — Prescaler Select Bits

These read/write bits select either the PTD4/ATD12/TBCLK pin or one of the seven prescaler outputs as the input to the TIMB counter as **Table 18-1** shows. Reset clears the PS[2:0] bits.

Table 18-1. Prescaler Selection

PS[2:0]	TIMB Clock Source
000	Internal Bus Clock ÷ 1
001	Internal Bus Clock ÷ 2
010	Internal Bus Clock ÷ 4
011	Internal Bus Clock ÷ 8
100	Internal Bus Clock ÷ 16
101	Internal Bus Clock ÷ 32
110	Internal Bus Clock ÷ 64
111	PTD4/ATD12/TBCLK

18.9.2 TIMB Counter Registers

The two read-only TIMB counter registers contain the high and low bytes of the value in the TIMB counter. Reading the high byte (TBCNTH) latches the contents of the low byte (TBCNTL) into a buffer. Subsequent reads of TBCNTH do not affect the latched TBCNTL value until TBCNTL is read. Reset clears the TIMB counter registers. Setting the TIMB reset bit (TRST) also clears the TIMB counter registers.

NOTE: *If TBCNTH is read during a break interrupt, be sure to unlatch TBCNTL by reading TBCNTL before exiting the break interrupt. Otherwise, TBCNTL retains the value latched during the break.*

Timer Interface Module B (TIMB)

Register Name and Address TBCNTH — \$0041

	Bit 7	6	5	4	3	2	1	Bit 0
Read:	BIT 15	BIT 14	BIT 13	BIT 12	BIT 11	BIT 10	BIT 9	BIT 8
Write:	R	R	R	R	R	R	R	R
Reset:	0	0	0	0	0	0	0	0

Register Name and Address TBCNTL — \$0042

	Bit 7	6	5	4	3	2	1	Bit 0
Read:	BIT 7	BIT 6	BIT 5	BIT 4	BIT 3	BIT 2	BIT 1	BIT 0
Write:	R	R	R	R	R	R	R	R
Reset:	0	0	0	0	0	0	0	0

R	R = Reserved
---	--------------

Figure 18-5. TIMB Counter Registers (TBCNTH and TBCNTL)

18.9.3 TIMB Counter Modulo Registers

The read/write TIMB modulo registers contain the modulo value for the TIMB counter. When the TIMB counter reaches the modulo value, the overflow flag (TOF) becomes set and the TIMB counter resumes counting from \$0000 at the next timer clock. Writing to the high byte (TBMODH) inhibits the TOF bit and overflow interrupts until the low byte (TBMODL) is written. Reset sets the TIMB counter modulo registers.

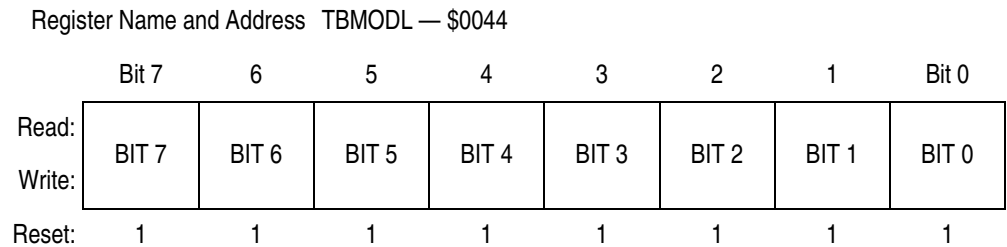
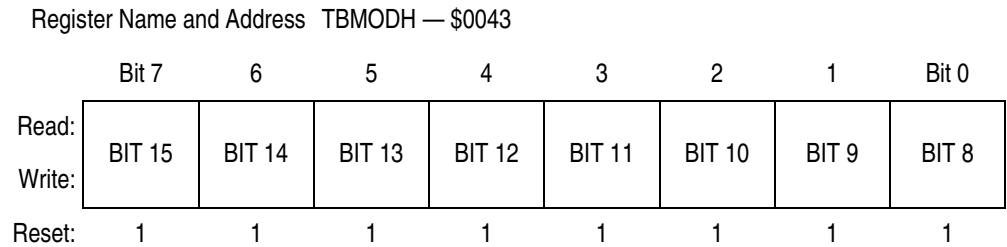

Figure 18-6. TIMB Counter Modulo Registers (TBMODH and TBMODL)

NOTE: *Reset the TIMB counter before writing to the TIMB counter modulo registers.*

18.9.4 TIMB Channel Status and Control Registers

Each of the TIMB channel status and control registers:

- Flags input captures and output compares
- Enables input capture and output compare interrupts
- Selects input capture, output compare or PWM operation
- Selects high, low or toggling output on output compare
- Selects rising edge, falling edge or any edge as the active input capture trigger
- Selects output toggling on TIMB overflow
- Selects 0% and 100% PWM duty cycle
- Selects buffered or unbuffered output compare/PWM operation

Register Name and Address TBSC0 — \$0045

	Bit 7	6	5	4	3	2	1	Bit 0
Read:	CH0F	CH0IE	MS0B	MS0A	ELS0B	ELS0A	TOV0	CH0MAX
Write:	0							
Reset:	0	0	0	0	0	0	0	0

Register Name and Address TBSC1 — \$0048

	Bit 7	6	5	4	3	2	1	Bit 0
Read:	CH1F	CH1IE	0	MS1A	ELS1B	ELS1A	TOV1	CH1MAX
Write:	0		R					
Reset:	0	0	0	0	0	0	0	0

R

 R = Reserved

Figure 18-7. TIMB Channel Status and Control Registers (TBSC0–TBSC1)

CHxF — Channel x Flag Bit

When channel x is an input capture channel, this read/write bit is set when an active edge occurs on the channel x pin. When channel x is an output compare channel, CHxF is set when the value in the TIMB counter registers matches the value in the TIMB channel x registers.

When CHxIE = 1, clear CHxF by reading TIMB channel x status and control register with CHxF set, and then writing a logic 0 to CHxF. If another interrupt request occurs before the clearing sequence is complete, then writing logic 0 to CHxF has no effect. Therefore, an interrupt request cannot be lost due to inadvertent clearing of CHxF.

Reset clears the CHxF bit. Writing a logic 1 to CHxF has no effect.

- 1 = Input capture or output compare on channel x
- 0 = No input capture or output compare on channel x

CHxIE — Channel x Interrupt Enable Bit

This read/write bit enables TIMB CPU interrupts on channel x.

Reset clears the CHxIE bit.

- 1 = Channel x CPU interrupt requests enabled
- 0 = Channel x CPU interrupt requests disabled

MSxB — Mode Select Bit B

This read/write bit selects buffered output compare/PWM operation. MSxB exists only in the TIMB channel 0.

Setting MS0B disables the channel 1 status and control register and reverts TBCH1 to general-purpose I/O.

Reset clears the MSxB bit.

- 1 = Buffered output compare/PWM operation enabled
- 0 = Buffered output compare/PWM operation disabled

MSxA — Mode Select Bit A

When ELSxB:A \neq 00, this read/write bit selects either input capture operation or unbuffered output compare/PWM operation (see [Table 18-2](#)).

1 = Unbuffered output compare/PWM operation

0 = Input capture operation

When ELSxB:A = 00, this read/write bit selects the initial output level of the TBCHx pin once PWM, input capture or output compare operation is enabled (see [Table 18-2](#)). Reset clears the MSxA bit.

1 = Initial output level low

0 = Initial output level high

NOTE: *Before changing a channel function by writing to the MSxB or MSxA bit, set the TSTOP and TRST bits in the TIMB status and control register (TBSC).*

ELSxB and ELSxA — Edge/Level Select Bits

When channel x is an input capture channel, these read/write bits control the active edge-sensing logic on channel x.

When channel x is an output compare channel, ELSxB and ELSxA control the channel x output behavior when an output compare occurs.

When ELSxB and ELSxA are both clear, channel x is not connected to port F and pin PTFx/TBCHx is available as a general-purpose I/O pin. However, channel x is at a state determined by these bits and becomes transparent to the respective pin when PWM, input capture, or output compare mode is enabled. [Table 18-2](#) shows how ELSxB and ELSxA work. Reset clears the ELSxB and ELSxA bits.

Table 18-2. Mode, Edge, and Level Selection

MSxB:MSxA	ELSxB:ELSxA	Mode	Configuration
X0	00	Output Preset	Pin under Port Control; Initialize Timer Output Level High
X1	00		Pin under Port Control; Initialize Timer Output Level Low
00	01	Input Capture	Capture on Rising Edge Only
00	10		Capture on Falling Edge Only
00	11		Capture on Rising or Falling Edge
01	01	Output Compare or PWM	Toggle Output on Compare
01	10		Clear Output on Compare
01	11		Set Output on Compare
1X	01	Buffered Output Compare or Buffered PWM	Toggle Output on Compare
1X	10		Clear Output on Compare
1X	11		Set Output on Compare

NOTE: Before enabling a TIMB channel register for input capture operation, make sure that the PTFx/TBCHx pin is stable for at least two bus clocks.

TOVx — Toggle-On-Overflow Bit

When channel x is an output compare channel, this read/write bit controls the behavior of the channel x output when the TIMB counter overflows. When channel x is an input capture channel, TOVx has no effect. Reset clears the TOVx bit.

1 = Channel x pin toggles on TIMB counter overflow.

0 = Channel x pin does not toggle on TIMB counter overflow.

NOTE: When TOVx is set, a TIMB counter overflow takes precedence over a channel x output compare if both occur at the same time.

CHxMAX — Channel x Maximum Duty Cycle Bit

When the TOVx bit is at logic 1, setting the CHxMAX bit forces the duty cycle of buffered and unbuffered PWM signals to 100%. As **Figure 18-8** shows, the CHxMAX bit takes effect in the cycle after it is set or cleared. The output stays at the 100% duty cycle level until the cycle after CHxMAX is cleared.

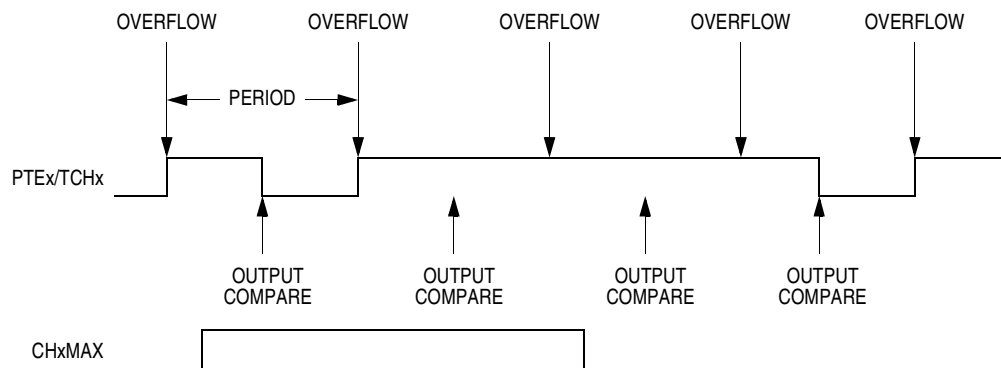

Figure 18-8. CHxMAX Latency

18.9.5 TIMB Channel Registers

These read/write registers contain the captured TIMB counter value of the input capture function or the output compare value of the output compare function. The state of the TIMB channel registers after reset is unknown.

In input capture mode ($MSxB-MSxA = 0:0$) reading the high byte of the TIMB channel x registers (TBCHxH) inhibits input captures until the low byte (TBCHxL) is read.

In output compare mode ($MSxB-MSxA \neq 0:0$) writing to the high byte of the TIMB channel x registers (TBCHxH) inhibits output compares and the CHxF bit until the low byte (TBCHxL) is written.

Register Name and Address TBCH0H — \$0046

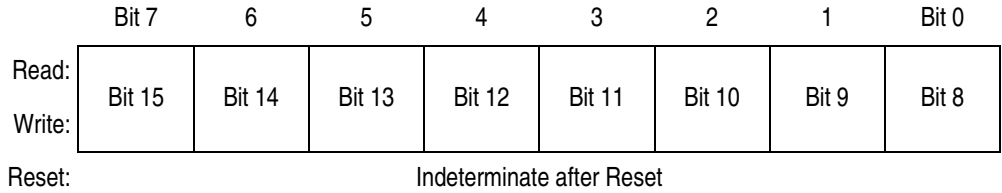

Register Name and Address TBCH0L — \$0047

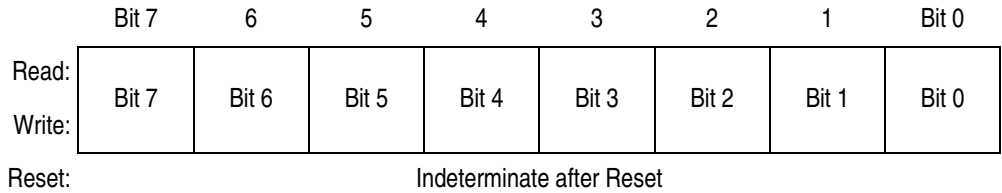

Register Name and Address TBCH1H — \$0049

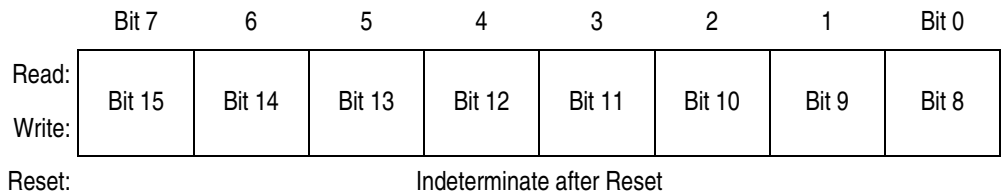

Register Name and Address TBCH1L — \$004A

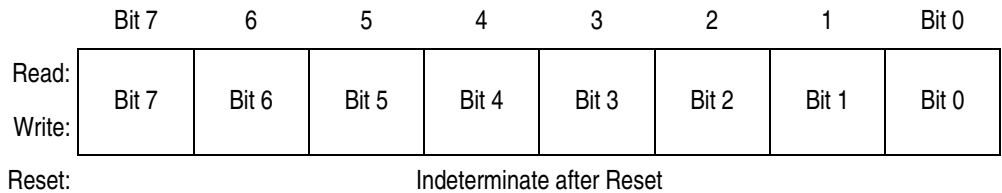

Figure 18-9. TIMB Channel Registers (TBCH0H/L–TBCH1H/L)

Section 19. Programmable Interrupt Timer (PIT)

19.1 Contents

19.2	Introduction	293
19.3	Features	294
19.4	Functional Description	294
19.5	PIT Counter Prescaler	296
19.6	Low-Power Modes	296
19.6.1	Wait Mode	296
19.6.2	Stop Mode	296
19.7	PIT During Break Interrupts	297
19.8	I/O Registers	297
19.8.1	PIT Status and Control Register	297
19.8.2	PIT Counter Registers	300
19.8.3	PIT Counter Modulo Registers	301

19.2 Introduction

This section describes the Programmable Interrupt Timer (PIT) which is a periodic interrupt timer whose counter is clocked internally via software programmable options. **Figure 19-1** is a block diagram of the PIT.

For further information regarding timers on M68HC08 family devices, please consult the HC08 Timer Reference Manual, TIM08RM/AD.

Programmable Interrupt Timer (PIT)

19.3 Features

Features of the PIT include:

- Programmable PIT Clock Input
- Free-Running or Modulo Up-Count Operation
- PIT Counter Stop and Reset Bits

19.4 Functional Description

Figure 19-1 shows the structure of the PIT. The central component of the PIT is the 16-bit PIT counter that can operate as a free-running counter or a modulo up-counter. The counter provides the timing reference for the interrupt. The PIT counter modulo registers, PMODH–PMODL, control the modulo value of the counter. Software can read the counter value at any time without affecting the counting sequence.

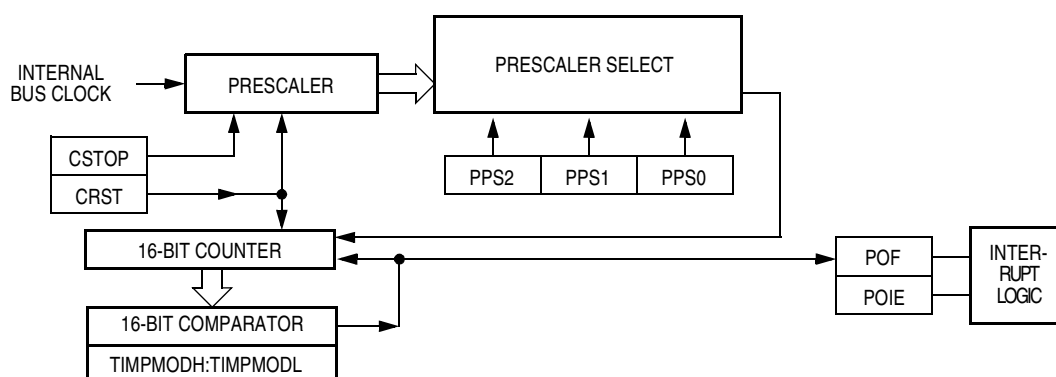

Figure 19-1. PIT Block Diagram

Register Name	Bit 7	6	5	4	3	2	1	Bit 0	
PIT Status and Control Register (PSC)	Read:	POF	POIE	PSTOP	0	0	PPS2	PPS1	PPS0
	Write:	0			PRST				
	Reset:	0	0	1	0	0	0	0	0
PIT Counter Register High (PCNTH)	Read:	Bit 15	14	13	12	11	10	9	Bit 8
	Write:								
	Reset:	0	0	0	0	0	0	0	0
PIT Counter Register Low (PCNTL)	Read:	Bit 7	6	5	4	3	2	1	Bit 0
	Write:								
	Reset:	0	0	0	0	0	0	0	0
PIT Counter Modulo Register High (PMDH)	Read:	Bit 15	14	13	12	11	10	9	Bit 8
	Write:								
	Reset:	1	1	1	1	1	1	1	1
PIT Counter Modulo Register Low (PMDL)	Read:	Bit 7	6	5	4	3	2	1	Bit 0
	Write:								
	Reset:	1	1	1	1	1	1	1	1

=Unimplemented

Figure 19-2. PIT I/O Register Summary

Table 19-1. PIT I/O Register Address Summary

Register	PSC	PCNTH	PCNTL	PMDH	PMDL
Address	\$004B	\$004C	\$004D	\$004E	\$004F

19.5 PIT Counter Prescaler

The clock source can be one of the seven prescaler outputs. The prescaler generates seven clock rates from the internal bus clock. The prescaler select bits, PPS[2:0], in the status and control register select the PIT clock source.

The value in the PIT counter modulo registers and the selected prescaler output determines the frequency of the periodic interrupt. The PIT overflow flag (POF) is set when the PIT counter value reaches the modulo value programmed in the PIT counter modulo registers. The PIT interrupt enable bit, POIE, enables PIT overflow CPU interrupt requests. POF and POIE are in the PIT status and control register.

19.6 Low-Power Modes

The WAIT and STOP instructions put the MCU in low power-consumption standby modes.

19.6.1 Wait Mode

The PIT remains active after the execution of a WAIT instruction. In wait mode the PIT registers are not accessible by the CPU. Any enabled CPU interrupt request from the PIT can bring the MCU out of wait mode.

If PIT functions are not required during wait mode, reduce power consumption by stopping the PIT before executing the WAIT instruction.

19.6.2 Stop Mode

The PIT is inactive after the execution of a STOP instruction. The STOP instruction does not affect register conditions or the state of the PIT counter. PIT operation resumes when the MCU exits stop mode after an external interrupt.

19.7 PIT During Break Interrupts

A break interrupt stops the PIT counter.

The system integration module (SIM) controls whether status bits in other modules can be cleared during the break state. The BCFE bit in the SIM break flag control register (SBFCR) enables software to clear status bits during the break state (see [SIM Break Flag Control Register](#) on page 122).

To allow software to clear status bits during a break interrupt, write a logic 1 to the BCFE bit. If a status bit is cleared during the break state, it remains cleared when the MCU exits the break state.

To protect status bits during the break state, write a logic 0 to the BCFE bit. With BCFE at logic 0 (its default state), software can read and write I/O registers during the break state without affecting status bits. Some status bits have a 2-step read/write clearing procedure. If software does the first step on such a bit before the break, the bit cannot change during the break state as long as BCFE is at logic 0. After the break, doing the second step clears the status bit.

19.8 I/O Registers

The following I/O registers control and monitor operation of the PIT:

- PIT status and control register (PSC)
- PIT counter registers (PCNTH–PCNTL)
- PIT counter modulo registers (PMDH–PMDL)

19.8.1 PIT Status and Control Register

The PIT status and control register:

- Enables PIT interrupt
- Flags PIT overflows
- Stops the PIT counter

Programmable Interrupt Timer (PIT)

- Resets the PIT counter
- Prescales the PIT counter clock

Address: \$004B

	Bit 7	6	5	4	3	2	1	Bit 0
Read:	POF	POIE	PSTOP	0	0	PPS2	PPS1	PPS0
Write:	0			PRST				
Reset:	0	0	1	0	0	0	0	0

 = Unimplemented

Figure 19-3. PIT Status and Control Register (PSC)

POF — PIT Overflow Flag Bit

This read/write flag is set when the PIT counter reaches the modulo value programmed in the PIT counter modulo registers. Clear POF by reading the PIT status and control register when POF is set and then writing a logic 0 to POF. If another PIT overflow occurs before the clearing sequence is complete, then writing logic 0 to POF has no effect. Therefore, a POF interrupt request cannot be lost due to inadvertent clearing of POF. Reset clears the POF bit. Writing a logic 1 to POF has no effect.

- 1 = PIT counter has reached modulo value
- 0 = PIT counter has not reached modulo value

POIE — PIT Overflow Interrupt Enable Bit

This read/write bit enables PIT overflow interrupts when the POF bit becomes set. Reset clears the POIE bit.

- 1 = PIT overflow interrupts enabled
- 0 = PIT overflow interrupts disabled

PSTOP — PIT Stop Bit

This read/write bit stops the PIT counter. Counting resumes when PSTOP is cleared. Reset sets the PSTOP bit, stopping the PIT counter until software clears the PSTOP bit.

- 1 = PIT counter stopped
- 0 = PIT counter active

NOTE: Do not set the *PSTOP* bit before entering wait mode if the PIT is required to exit wait mode.

PRST — PIT Reset Bit

Setting this write-only bit resets the PIT counter and the PIT prescaler. Setting PRST has no effect on any other registers. Counting resumes from \$0000. PRST is cleared automatically after the PIT counter is reset and always reads as logic zero. Reset clears the PRST bit.

1 = Prescaler and PIT counter cleared

0 = No effect

NOTE: Setting the *PSTOP* and *PRST* bits simultaneously stops the PIT counter at a value of \$0000.

PPS[2:0] — Prescaler Select Bits

These read/write bits select one of the seven prescaler outputs as the input to the PIT counter as [Table 19-2](#) shows. Reset clears the PPS[2:0] bits.

Table 19-2. Prescaler Selection

PPS[2:0]	PIT Clock Source
000	Internal Bus Clock ÷ 1
001	Internal Bus Clock ÷ 2
010	Internal Bus Clock ÷ 4
011	Internal Bus Clock ÷ 8
100	Internal Bus Clock ÷ 16
101	Internal Bus Clock ÷ 32
110	Internal Bus Clock ÷ 64
111	Internal Bus Clock ÷ 64

Programmable Interrupt Timer (PIT)

19.8.2 PIT Counter Registers

The two read-only PIT counter registers contain the high and low bytes of the value in the PIT counter. Reading the high byte (PCNTH) latches the contents of the low byte (PCNTL) into a buffer. Subsequent reads of PCNTH do not affect the latched PCNTL value until PCNTL is read. Reset clears the PIT counter registers. Setting the PIT reset bit (PRST) also clears the PIT counter registers.

NOTE: *If you read PCNTH during a break interrupt, be sure to unlatch PCNTL by reading PCNTL before exiting the break interrupt. Otherwise, PCNTL retains the value latched during the break.*

Address: \$004C

	Bit 7	6	5	4	3	2	1	Bit 0
Read:	Bit 15	14	13	12	11	10	9	Bit 8
Write:								
Reset:	0	0	0	0	0	0	0	0

Address: \$004D

	Bit 7	6	5	4	3	2	1	Bit 0
Read:	Bit 15	14	13	12	11	10	9	Bit 8
Write:								
Reset:	0	0	0	0	0	0	0	0

 = Unimplemented

Figure 19-4. PIT Counter Registers (PCNTH–PCNTL)

19.8.3 PIT Counter Modulo Registers

The read/write PIT modulo registers contain the modulo value for the PIT counter. When the PIT counter reaches the modulo value the overflow flag (POF) becomes set and the PIT counter resumes counting from \$0000 at the next timer clock. Writing to the high byte (PMDH) inhibits the POF bit and overflow interrupts until the low byte (PMDL) is written. Reset sets the PIT counter modulo registers.

Address: \$004E:\$004F

	Bit 7	6	5	4	3	2	1	Bit 0
Read:	Bit 15	14	13	12	11	10	9	Bit 8
Write:								
Reset:	1	1	1	1	1	1	1	1

Address: \$004E:\$004F

	Bit 7	6	5	4	3	2	1	Bit 0
Read:	Bit 7	6	5	4	3	2	1	Bit 0
Write:								
Reset:	1	1	1	1	1	1	1	1

Figure 19-5. PIT Counter Modulo Registers (PMDH–PMDL)

NOTE: Reset the PIT counter before writing to the PIT counter modulo registers.

Programmable Interrupt Timer (PIT)

Section 20. Input/Output Ports

20.1 Contents

20.2	Introduction	304
20.3	Port A	305
	Port A Data Register	305
	Data Direction Register A	305
20.4	Port B	307
	Port B Data Register	307
	Data Direction Register B	308
20.5	Port C	310
	Port C Data Register	310
	Data Direction Register C	311
20.6	Port D	313
	Port D Data Register	313
	Data Direction Register D	314
20.7	Port E	316
	Port E Data Register	316
	Data Direction Register E	318
20.8	Port F	320
	Port F Data Register	320
	Data Direction Register F	321

20.2 Introduction

On the 52-pin MC68HC908AS60A, forty bidirectional input/output (I/O) form six parallel ports. All I/O pins are programmable as inputs or outputs.

NOTE: *Connect any unused I/O pins to an appropriate logic level, either V_{DD} or V_{SS} . Although the I/O ports do not require termination for proper operation, termination reduces excess current consumption and the possibility of electrostatic damage.*

Figure 20-1. I/O Port Register Summary

Addr.	Register Name	Bit 7	6	5	4	3	2	1	Bit 0
\$0000	Port A Data Register (PTA)	PTA7	PTA6	PTA5	PTA4	PTA3	PTA2	PTA1	PTA0
\$0001	Port B Data Register (PTB)	PTB7	PTB6	PTB5	PTB4	PTB3	PTB2	PTB1	PTB0
\$0002	Port C Data Register (PTC)	0	0	0	PTC4	PTC3	PTC2	PTC1	PTC0
\$0003	Port D Data Register (PTD)	0	PTD6	PTD5	PTD4	PTD3	PTD2	PTD1	PTD0
\$0004	Data Direction Register A (DDRA)	DDRA7	DDRA6	DDRA5	DDRA4	DDRA3	DDRA2	DDRA1	DDRA0
\$0005	Data Direction Register B (DDRB)	DDRB7	DDRB6	DDRB5	DDRB4	DDRB3	DDRB2	DDRB1	DDRB0
\$0006	Data Direction Register C (DDRC)	MCLKEN	0	0	DDRC4	DDRC3	DDRC2	DDRC1	DDRC0
\$0007	Data Direction Register D (DDRD)	0	DDRD6	DDRD5	DDRD4	DDRD3	DDRD2	DDRD1	DDRD0
\$0008	Port E Data Register (PTE)	PTE7	PTE6	PTE5	PTE4	PTE3	PTE2	PTE1	PTE0
\$0009	Port F Data Register (PTF)	0	0	0	0	PTF3	PTF2	PTF1	PTF0
\$000C	Data Direction Register E (DDRE)	DDRE7	DDRE6	DDRE5	DDRE4	DDRE3	DDRE2	DDRE1	DDRE0
\$000D	Data Direction Register F (DDRF)	0	0	0	0	DDRF3	DDRF2	DDRF1	DDRF0

20.3 Port A

Port A is an 8-bit general-purpose bidirectional I/O port.

20.3.1 Port A Data Register

The port A data register contains a data latch for each of the eight port A pins.

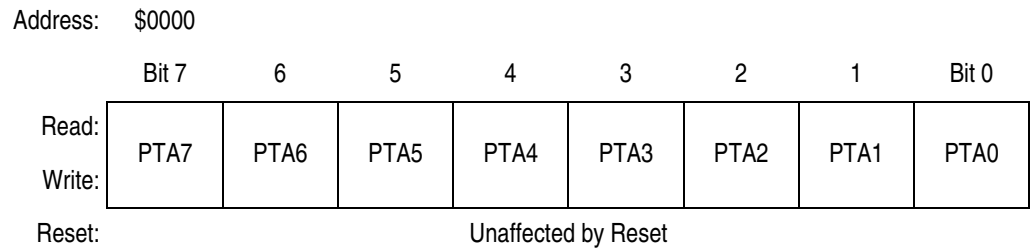

Figure 20-2. Port A Data Register (PTA)

PTA[7:0] — Port A Data Bits

These read/write bits are software programmable. Data direction of each port A pin is under the control of the corresponding bit in data direction register A. Reset has no effect on port A data.

20.3.2 Data Direction Register A

Data direction register A determines whether each port A pin is an input or an output. Writing a logic 1 to a DDRA bit enables the output buffer for the corresponding port A pin; a logic 0 disables the output buffer.

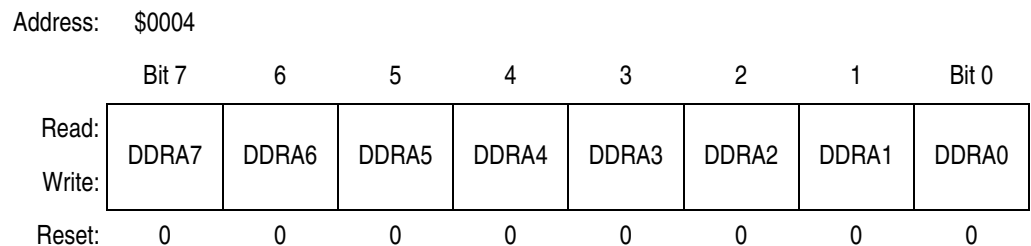

Figure 20-3. Data Direction Register A (DDRA)

DDRA[7:0] — Data Direction Register A Bits

These read/write bits control port A data direction. Reset clears DDRA[7:0], configuring all port A pins as inputs.

1 = Corresponding port A pin configured as output

0 = Corresponding port A pin configured as input

NOTE: Avoid glitches on port A pins by writing to the port A data register before changing data direction register A bits from 0 to 1.

Figure 20-4 shows the port A I/O logic.

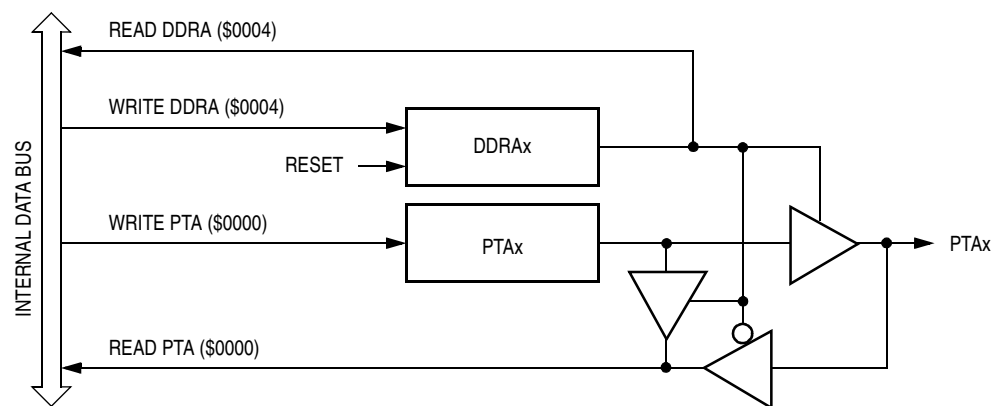

Figure 20-4. Port A I/O Circuit

When bit DDRAx is a logic 1, reading address \$0000 reads the PTAx data latch. When bit DDRAx is a logic 0, reading address \$0000 reads the voltage level on the pin. The data latch can always be written, regardless of the state of its data direction bit. Table 20-1 summarizes the operation of the port A pins.

Table 20-1. Port A Pin Functions

DDRA Bit	PTA Bit	I/O Pin Mode	Accesses to DDRA	Accesses to PTA	
			Read/Write	Read	Write
0	X	Input, Hi-Z	DDRA[7:0]	Pin	PTA[7:0] ⁽¹⁾
1	X	Output	DDRA[7:0]	PTA[7:0]	PTA[7:0]

X = don't care

Hi-Z = high impedance

1. Writing affects data register, but does not affect input.

20.4 Port B

Port B is an 8-bit special function port that shares all of its pins with the analog-to-digital converter.

20.4.1 Port B Data Register

The port B data register contains a data latch for each of the eight port B pins.

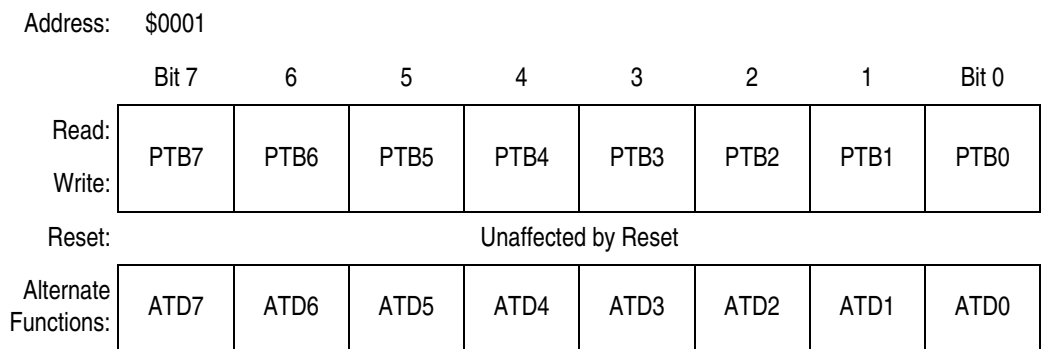

Figure 20-5. Port B Data Register (PTB)

PTB[7:0] — Port B Data Bits

These read/write bits are software programmable. Data direction of each port B pin is under the control of the corresponding bit in data direction register B. Reset has no effect on port B data.

ATD[7:0] — ADC Channels

PTB7/ATD7–PTB0/ATD0 are eight of the analog-to-digital converter channels. The ADC channel select bits, CH[4:0], determine whether the PTB7/ATD7–PTB0/ATD0 pins are ADC channels or general-purpose I/O pins. If an ADC channel is selected and a read of this corresponding bit in the port B data register occurs, the data will be 0 if the data direction for this bit is programmed as an input. Otherwise, the data will reflect the value in the data latch. (See [Analog-to-Digital Converter \(ADC\)](#) on page 361). Data direction register B (DDRB) does not affect the data direction of port B pins that are being used by the ADC. However, the DDRB bits always determine whether reading port B returns to the states of the latches or logic 0.

20.4.2 Data Direction Register B

Data direction register B determines whether each port B pin is an input or an output. Writing a logic 1 to a DDRB bit enables the output buffer for the corresponding port B pin; a logic 0 disables the output buffer.

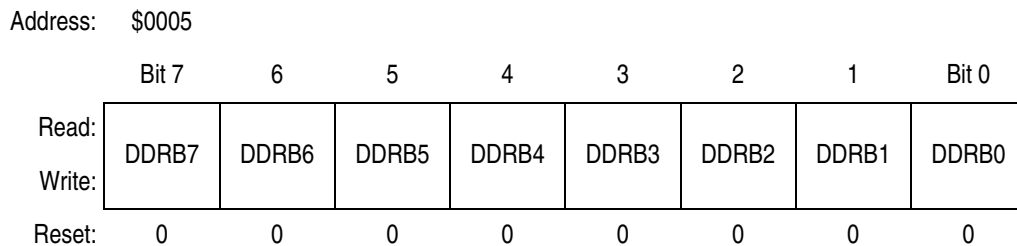

Figure 20-6. Data Direction Register B (DDRB)

DDRB[7:0] — Data Direction Register B Bits

These read/write bits control port B data direction. Reset clears DDRB[7:0], configuring all port B pins as inputs.

- 1 = Corresponding port B pin configured as output
- 0 = Corresponding port B pin configured as input

NOTE: *Avoid glitches on port B pins by writing to the port B data register before changing data direction register B bits from 0 to 1.*

[Figure 20-7](#) shows the port B I/O logic.

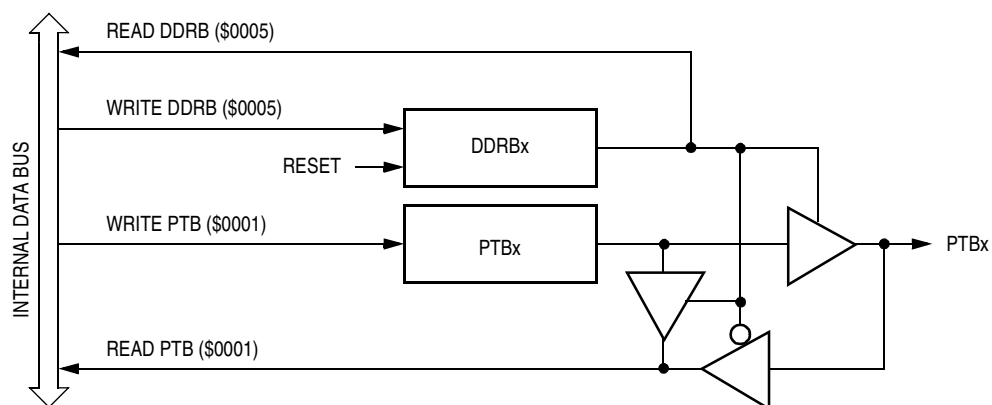

Figure 20-7. Port B I/O Circuit

When bit DDRBx is a logic 1, reading address \$0001 reads the PTBx data latch. When bit DDRBx is a logic 0, reading address \$0001 reads the voltage level on the pin. The data latch can always be written, regardless of the state of its data direction bit. [Table 20-2](#) summarizes the operation of the port B pins.

Table 20-2. Port B Pin Functions

DDRB Bit	PTB Bit	I/O Pin Mode	Accesses to DDRB	Accesses to PTB	
			Read/Write	Read	Write
0	X	Input, Hi-Z	DDRB[7:0]	Pin	PTB[7:0] ⁽¹⁾
1	X	Output	DDRB[7:0]	PTB[7:0]	PTB[7:0]

X = don't care

Hi-Z = high impedance

1. Writing affects data register, but does not affect input.

20.5 Port C

Port C is an 5-bit general-purpose bidirectional I/O port.

20.5.1 Port C Data Register

The port C data register contains a data latch for each of the five port C pins.

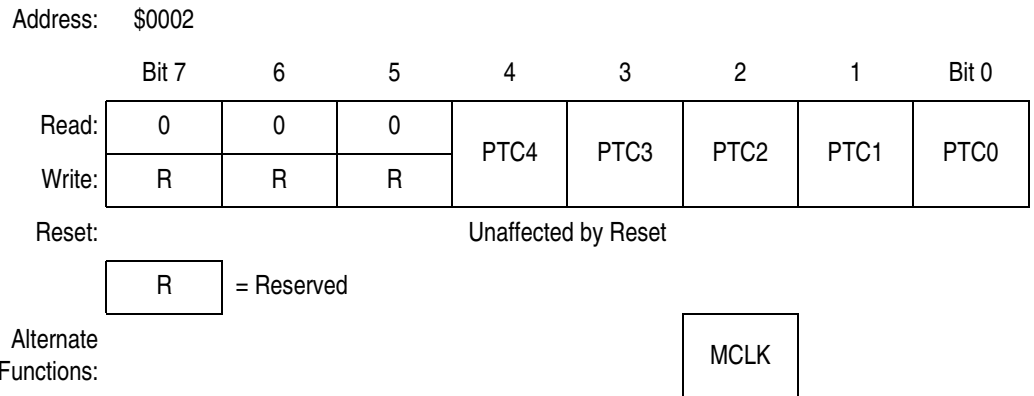

Figure 20-8. Port C Data Register (PTC)

PTC[4:0] — Port C Data Bits

These read/write bits are software-programmable. Data direction of each port C pin is under the control of the corresponding bit in data direction register C. Reset has no effect on port C data (4:0).

MCLK — System Clock Bit

The system clock is driven out of PTC2 when enabled by MCLKEN bit in PTCDDR7.

20.5.2 Data Direction Register C

Data direction register C determines whether each port C pin is an input or an output. Writing a logic 1 to a DDRC bit enables the output buffer for the corresponding port C pin; a logic 0 disables the output buffer.

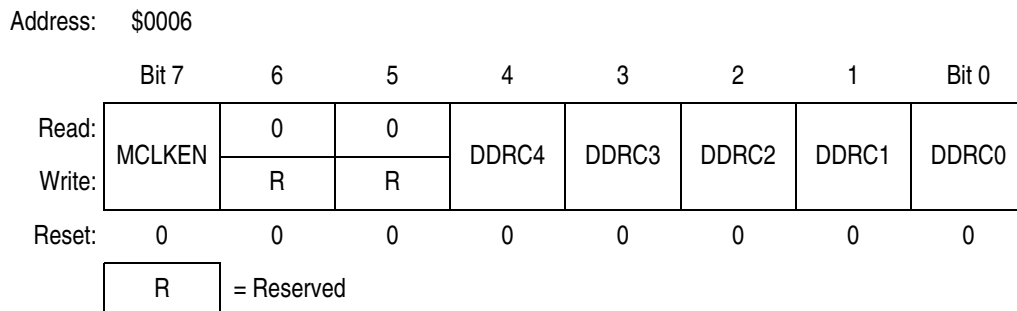

Figure 20-9. Data Direction Register C (DDRC)

MCLKEN — MCLK Enable Bit

This read/write bit enables MCLK to be an output signal on PTC2. If MCLK is enabled, DDRC2 has no effect. Reset clears this bit.

1 = MCLK output enabled

0 = MCLK output disabled

DDRC[4:0] — Data Direction Register C Bits

These read/write bits control port C data direction. Reset clears DDRC[4:0], configuring all port C pins as inputs.

1 = Corresponding port C pin configured as output

0 = Corresponding port C pin configured as input

NOTE: *Avoid glitches on port C pins by writing to the port C data register before changing data direction register C bits from 0 to 1.*

Figure 20-10 shows the port C I/O logic.

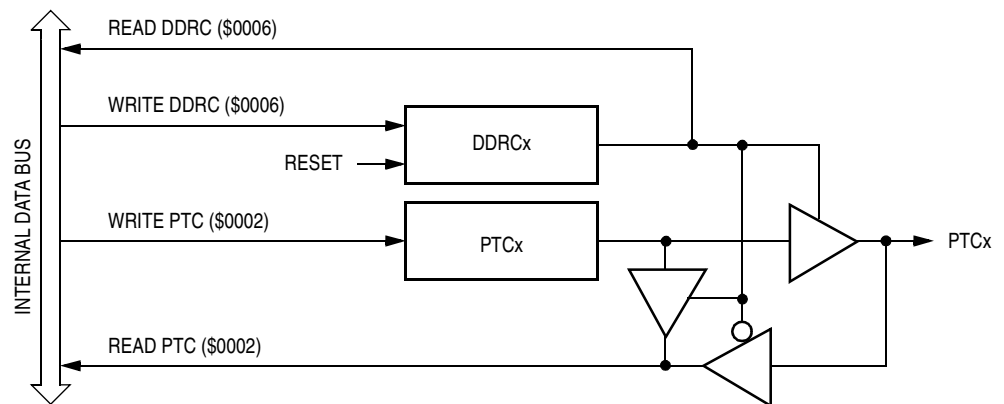

Figure 20-10. Port C I/O Circuit

When bit DDRCx is a logic 1, reading address \$0002 reads the PTCx data latch. When bit DDRCx is a logic 0, reading address \$0002 reads the voltage level on the pin. The data latch can always be written, regardless of the state of its data direction bit. [Table 20-3](#) summarizes the operation of the port C pins.

Table 20-3. Port C Pin Functions

Bit Value	PTC Bit	I/O Pin Mode	Accesses to DDRC	Accesses to PTC	
			Read/Write	Read	Write
0	2	Input, Hi-Z	DDRC[2]	Pin	PTC2
1	2	Output	DDRC[2]	0	—
0	X	Input, Hi-Z	DDRC[4:0]	Pin	PTC[4:0] ⁽¹⁾
1	X	Output	DDRC[4:0]	PTC[4:0]	PTC[4:0]

X = don't care

Hi-Z = high impedance

1. Writing affects data register, but does not affect input.

20.6 Port D

Port D is an 7-bit general-purpose I/O port.

20.6.1 Port D Data Register

Port D is a 7-bit special function port that shares seven of its pins with the analog to digital converter and two with the timer interface modules.

Address: \$0003

	Bit 7	6	5	4	3	2	1	Bit 0
Read:	0	PTD6	PTD5	PTD4	PTD3	PTD2	PTD1	PTD0
Write:	R							
Reset:	Unaffected by Reset							
Alternate Functions:	R	ATD14/ TACLK	ATD13	ATD12/ TBCLK	ATD11	ATD10	ATD9	ATD8

Figure 20-11. Port D Data Register (PTD)

PTD[6:0] — Port D Data Bits

PTD[6:0] are read/write, software programmable bits. Data direction of PTD[6:0] pins are under the control of the corresponding bit in data direction register D.

ATD[14:8] — ADC Channel Status Bits

PTD6/ATD14/TACLK–PTD0/ATD8 are seven of the 15 analog-to-digital converter channels. The ADC channel select bits, CH[4:0], determine whether the PTD6/ATD14/TACLK–PTD0/ATD8 pins are ADC channels or general-purpose I/O pins. If an ADC channel is selected and a read of this corresponding bit in the port B data register occurs, the data will be 0 if the data direction for this bit is programmed as an input. Otherwise, the data will reflect the value in the data latch. (See [Analog-to-Digital Converter \(ADC\)](#) on page 361).

Data direction register D (DDRD) does not affect the data direction of port D pins that are being used by the TIMA. However, the DDRD bits

always determine whether reading port D returns the states of the latches or logic 0.

TACLK/TBCLK — Timer Clock Input Bit

The PTD6/ATD14/TACLK pin is the external clock input for the TIMA. The prescaler select bits, PS[2:0], select PTD6/ATD14/TACLK as the TIM clock input. (See [TIMA Channel Status and Control Registers](#) on page 352). When not selected as the TIM clock, PTD6/ATD14/TACLK is available for general-purpose I/O. While TACLK is selected corresponding DDRD bits have no effect.

20.6.2 Data Direction Register D

Data direction register D determines whether each port D pin is an input or an output. Writing a logic 1 to a DDRD bit enables the output buffer for the corresponding port D pin; a logic 0 disables the output buffer.

Address: \$0007

	Bit 7	6	5	4	3	2	1	Bit 0
Read:	0	DDRD6	DDRD5	DDRD4	DDRD3	DDRD2	DDRD1	DDRD0
Write:	R							
Reset:	0	0	0	0	0	0	0	0

Figure 20-12. Data Direction Register D (DDRD)

DDRD[6:0] — Data Direction Register D Bits

These read/write bits control port D data direction. Reset clears DDRD[6:0], configuring all port D pins as inputs.

1 = Corresponding port D pin configured as output

0 = Corresponding port D pin configured as input

NOTE: Avoid glitches on port D pins by writing to the port D data register before changing data direction register D bits from 0 to 1.

[Figure 20-13](#) shows the port D I/O logic.

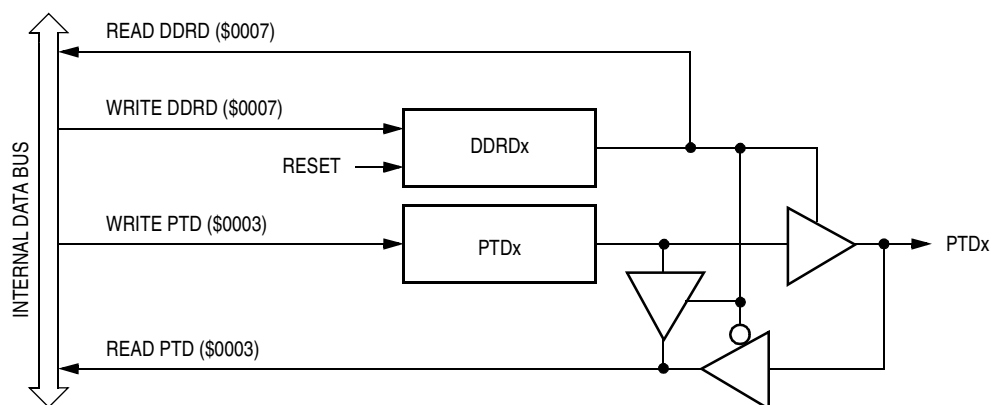

Figure 20-13. Port D I/O Circuit

When bit DDRDx is a logic 1, reading address \$0003 reads the PTDx data latch. When bit DDRDx is a logic 0, reading address \$0003 reads the voltage level on the pin. The data latch can always be written, regardless of the state of its data direction bit. [Table 20-4](#) summarizes the operation of the port D pins.

Table 20-4. Port D Pin Functions

DDRD Bit	PTD Bit	I/O Pin Mode	Accesses to DDRD	Accesses to PTD	
			Read/Write	Read	Write
0	X	Input, Hi-Z	DDRD[6:0]	Pin	PTD[6:0] ⁽¹⁾
1	X	Output	DDRD[6:0]	PTD[6:0]	PTD[6:0]

X = don't care

Hi-Z = high impedance

1. Writing affects data register, but does not affect input.

20.7 Port E

Port E is an 8-bit special function port that shares two of its pins with the timer interface module (TIMA), two of its pins with the serial communications interface module (SCI), and four of its pins with the serial peripheral interface module (SPI).

20.7.1 Port E Data Register

The port E data register contains a data latch for each of the eight port E pins.

Address: \$0008

	Bit 7	6	5	4	3	2	1	Bit 0
Read:	PTE7	PTE6	PTE5	PTE4	PTE3	PTE2	PTE1	PTE0
Write:	PTE7	PTE6	PTE5	PTE4	PTE3	PTE2	PTE1	PTE0
Reset:	Unaffected by Reset							
Alternate Function:	SPSCK	MOSI	MISO	\overline{SS}	TACH1	TACH0	RxD	TxD

Figure 20-14. Port E Data Register (PTE)

PTE[7:0] — Port E Data Bits

PTE[7:0] are read/write, software programmable bits. Data direction of each port E pin is under the control of the corresponding bit in data direction register E.

SPSCK — SPI Serial Clock Bit

The PTE7/SPSCK pin is the serial clock input of an SPI slave module and serial clock output of an SPI master module. When the SPE bit is clear, the PTE7/SPSCK pin is available for general-purpose I/O. (See [SPI Control Register](#) on page 260).

MOSI — Master Out/Slave In Bit

The PTE6/MOSI pin is the master out/slave in terminal of the SPI module. When the SPE bit is clear, the PTE6/MOSI pin is available for general-purpose I/O.

MISO — Master In/Slave Out Bit

The PTE5/MISO pin is the master in/slave out terminal of the SPI module. When the SPI enable bit, SPE, is clear, the SPI module is disabled, and the PTE5/MISO pin is available for general-purpose I/O. (See [SPI Control Register](#) on page 260).

 \overline{SS} — Slave Select Bit

The PTE4/ \overline{SS} pin is the slave select input of the SPI module. When the SPE bit is clear, or when the SPI master bit, SPMSTR, is set and MODFEN bit is low, the PTE4/ \overline{SS} pin is available for general-purpose I/O. (See [SS \(Slave Select\)](#) on page 258). When the SPI is enabled as a slave, the DDRF0 bit in data direction register E (DDRE) has no effect on the PTE4/ \overline{SS} pin.

NOTE: *Data direction register E (DDRE) does not affect the data direction of port E pins that are being used by the SPI module. However, the DDRE bits always determine whether reading port E returns the states of the latches or the states of the pins. (See [Table 20-5](#)).*

TACH[1:0] — Timer Channel I/O Bits

The PTE3/TACH1–PTE2/TACH0 pins are the TIM input capture/output compare pins. The edge/level select bits, ELSxB:ELSxA, determine whether the PTE3/TACH1–PTE2/TACH0 pins are timer channel I/O pins or general-purpose I/O pins. (See [TIMA Channel Status and Control Registers](#) on page 352).

NOTE: *Data direction register E (DDRE) does not affect the data direction of port E pins that are being used by the TIM. However, the DDRE bits always determine whether reading port E returns the states of the latches or the states of the pins. (See [Table 20-5](#)).*

RxD — SCI Receive Data Input Bit

The PTE1/RxD pin is the receive data input for the SCI module. When the enable SCI bit, ENSCI, is clear, the SCI module is disabled, and the PTE1/RxD pin is available for general-purpose I/O. (See [SCI Control Register 1](#) on page 217).

TxD — SCI Transmit Data Output

The PTE0/TxD pin is the transmit data output for the SCI module. When the enable SCI bit, ENSCI, is clear, the SCI module is disabled, and the PTE0/TxD pin is available for general-purpose I/O. (See [SCI Control Register 1](#) on page 217).

NOTE: *Data direction register E (DDRE) does not affect the data direction of port E pins that are being used by the SCI module. However, the DDRE bits always determine whether reading port E returns the states of the latches or the states of the pins. (See [Table 20-5](#)).*

20.7.2 Data Direction Register E

Data direction register E determines whether each port E pin is an input or an output. Writing a logic 1 to a DDRE bit enables the output buffer for the corresponding port E pin; a logic 0 disables the output buffer.

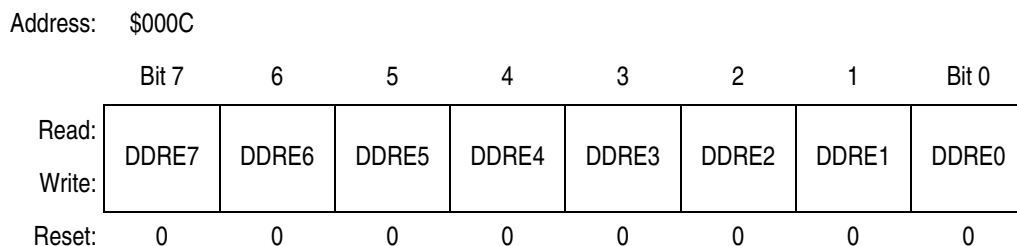

Figure 20-15. Data Direction Register E (DDRE)

DDRE[7:0] — Data Direction Register E Bits

These read/write bits control port E data direction. Reset clears DDRE[7:0], configuring all port E pins as inputs.

1 = Corresponding port E pin configured as output

0 = Corresponding port E pin configured as input

NOTE: *Avoid glitches on port E pins by writing to the port E data register before changing data direction register E bits from 0 to 1.*

[Figure 20-16](#) shows the port E I/O logic.

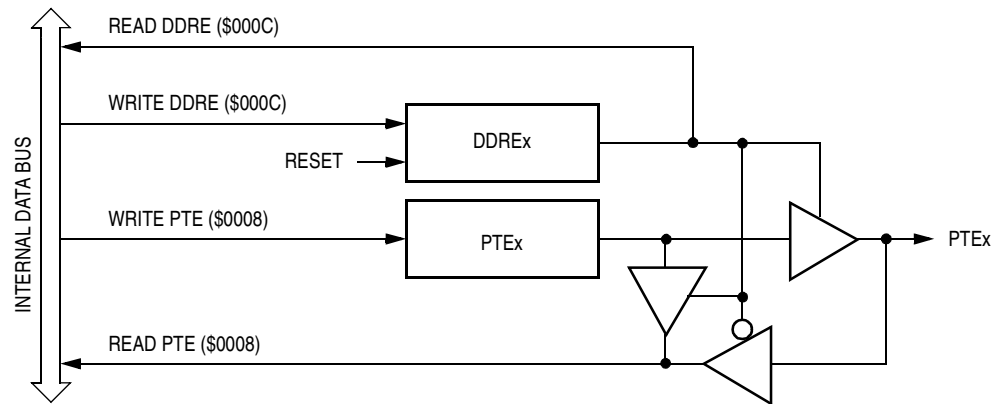

Figure 20-16. Port E I/O Circuit

When bit DDREx is a logic 1, reading address \$0008 reads the PTEx data latch. When bit DDREx is a logic 0, reading address \$0008 reads the voltage level on the pin. The data latch can always be written, regardless of the state of its data direction bit. [Table 20-5](#) summarizes the operation of the port E pins.

Table 20-5. Port E Pin Functions

DDRE Bit	PTE Bit	I/O Pin Mode	Accesses to DDRE	Accesses to PTE	
			Read/Write	Read	Write
0	X	Input, Hi-Z	DDRE[7:0]	Pin	PTE[7:0] ⁽¹⁾
1	X	Output	DDRE[7:0]	PTE[7:0]	PTE[7:0]

X = don't care

Hi-Z = high impedance

1. Writing affects data register, but does not affect input.

20.8 Port F

Port F is a 4-bit special function port that shares four of its pins with the timer interface module (TIMA-6).

20.8.1 Port F Data Register

The port F data register contains a data latch for each of the four port F pins.

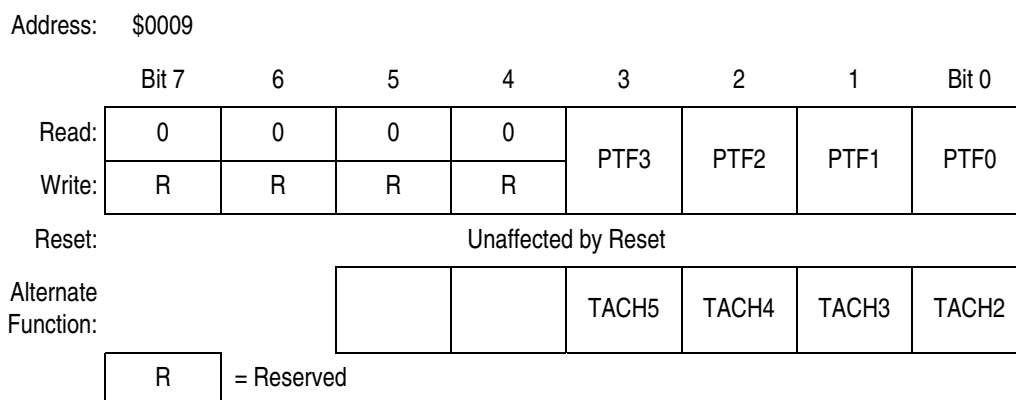

Figure 20-17. Port F Data Register (PTF)

PTF[3:0] — Port F Data Bits

These read/write bits are software programmable. Data direction of each port F pin is under the control of the corresponding bit in data direction register F. Reset has no effect on PTF[3:0].

TACH[5:2] — Timer A Channel I/O Bits

The PTF3–PTF0/TACH2 pins are the TIM input capture/output compare pins. The edge/level select bits, ELSxB:ELSxA, determine whether the PTF3–PTF0/TACH2 pins are timer channel I/O pins or general-purpose I/O pins. (See [TIMA Status and Control Register](#) on page 347).

NOTE: *Data direction register F (DDRF) does not affect the data direction of port F pins that are being used by the TIM. However, the DDRF bits always determine whether reading port F returns the states of the latches or the states of the pins. (See [Table 20-6](#)).*

20.8.2 Data Direction Register F

Data direction register F determines whether each port F pin is an input or an output. Writing a logic 1 to a DDRF bit enables the output buffer for the corresponding port F pin; a logic 0 disables the output buffer.

Address: \$000D

	Bit 7	6	5	4	3	2	1	Bit 0
Read:	0	0	0	0	DDRF3	DDRF2	DDRF1	DDRF0
Write:	R	R	R	R				
Reset:	0	0	0	0	0	0	0	0

R = Reserved

Figure 20-18. Data Direction Register F (DDRF)

DDRF[3:0] — Data Direction Register F Bits

These read/write bits control port F data direction. Reset clears DDRF[3:0], configuring all port F pins as inputs.

- 1 = Corresponding port F pin configured as output
- 0 = Corresponding port F pin configured as input

NOTE: Avoid glitches on port F pins by writing to the port F data register before changing data direction register F bits from 0 to 1.

Figure 20-19 shows the port F I/O logic.

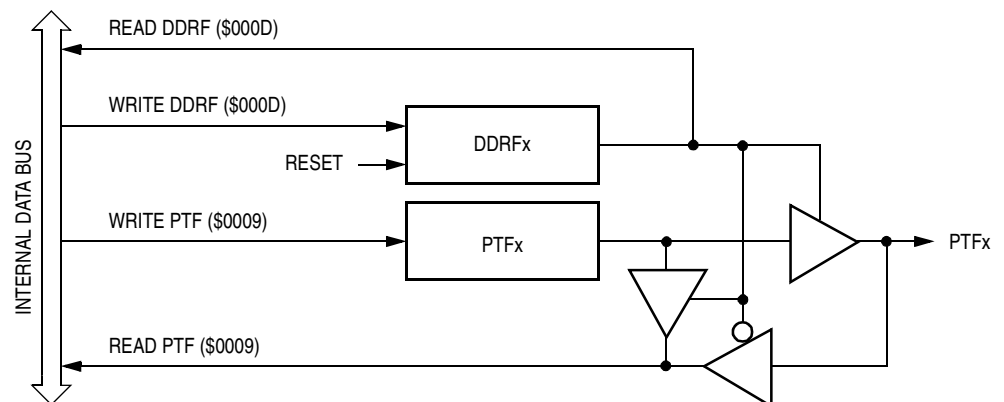

Figure 20-19. Port F I/O Circuit

When bit DDRF_x is a logic 1, reading address \$0009 reads the PTF_x data latch. When bit DDRF_x is a logic 0, reading address \$0009 reads the voltage level on the pin. The data latch can always be written, regardless of the state of its data direction bit. [Table 20-6](#) summarizes the operation of the port F pins.

Table 20-6. Port F Pin Functions

DDRF Bit	PTF Bit	I/O Pin Mode	Accesses to DDRF	Accesses to PTF	
			Read/Write	Read	Write
0	X	Input, Hi-Z	DDRF[3:0]	Pin	PTF[3:0] ⁽¹⁾
1	X	Output	DDRF[3:0]	PTF[3:0]	PTF[3:0]

X = don't care

Hi-Z = high impedance

1. Writing affects data register, but does not affect input.

Section 21. Keyboard Module (KBD)

21.1 Contents

21.2	Introduction	323
21.3	Features	324
21.4	Functional Description	324
21.5	Keyboard Initialization	327
21.6	Low-Power Modes	328
21.6.1	Wait Mode	328
21.6.2	Stop Mode	328
21.7	Keyboard Module During Break Interrupts	328
21.8	I/O Registers	329
21.8.1	Keyboard Status and Control Register	329
21.8.2	Keyboard Interrupt Enable Register	330

21.2 Introduction

The keyboard interrupt module (KBD) provides five independently maskable external interrupt pins.

This module is only available on 64-pin package options.

21.3 Features

KBD features include:

- Five Keyboard Interrupt Pins with Separate Keyboard Interrupt Enable Bits and One Keyboard Interrupt Mask
- Hysteresis Buffers
- Programmable Edge-Only or Edge- and Level- Interrupt Sensitivity
- Automatic Interrupt Acknowledge
- Exit from Low-Power Modes

21.4 Functional Description

Writing to the KBIE4–KBIE0 bits in the keyboard interrupt enable register independently enables or disables each port G or port H pin as a keyboard interrupt pin. Enabling a keyboard interrupt pin also enables its internal pullup device. A logic 0 applied to an enabled keyboard interrupt pin latches a keyboard interrupt request.

A keyboard interrupt is latched when one or more keyboard pins goes low after all were high. The MODEK bit in the keyboard status and control register controls the triggering mode of the keyboard interrupt.

- If the keyboard interrupt is edge-sensitive only, a falling edge on a keyboard pin does not latch an interrupt request if another keyboard pin is already low. To prevent losing an interrupt request on one pin because another pin is still low, software can disable the latter pin while it is low.
- If the keyboard interrupt is falling edge- and low level-sensitive, an interrupt request is present as long as any keyboard pin is low.

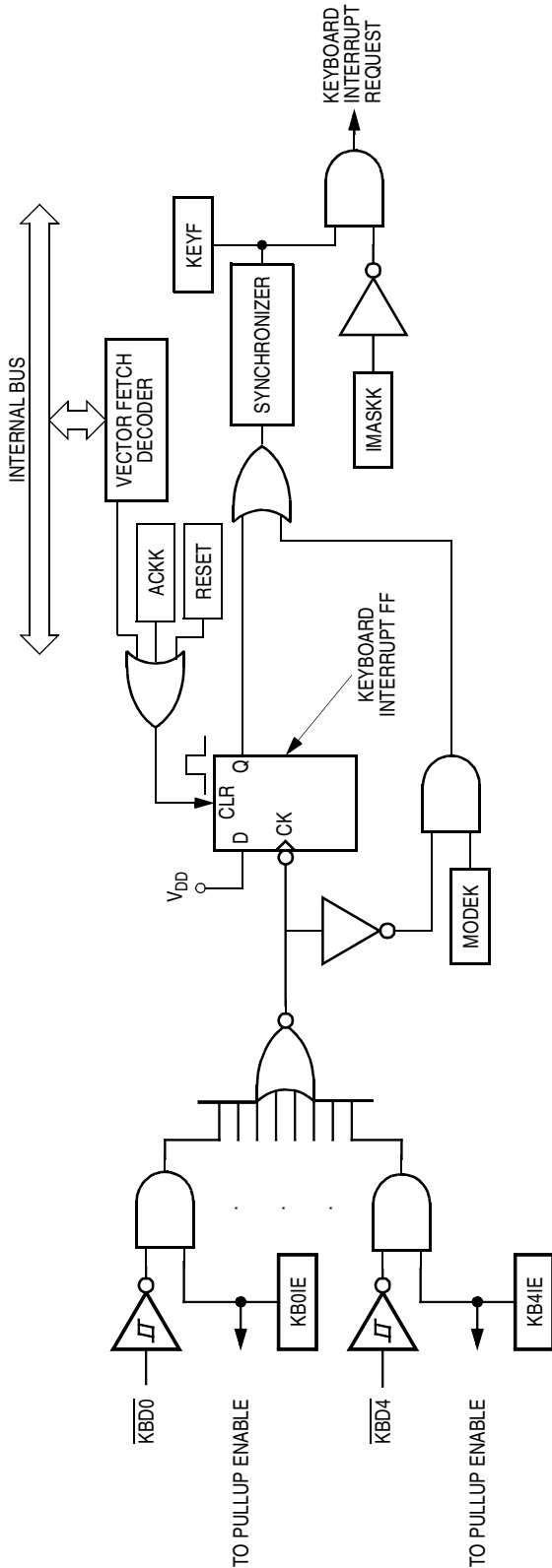

Figure 21-1. Keyboard Module Block Diagram

Register Name	Bit 7	Bit 6	Bit 5	Bit 4	Bit 3	Bit 2	Bit 1	Bit 0
Keyboard Status and Control Register (KBSCR)	Read: 0	0	0	0	KEYF	0	IMASKK	MODEK
	Write: 	 	 	 	 	ACKK	0	0
	Reset: 0	0	0	0	0	0	0	0
Keyboard Interrupt Enable Register (KBIER)	Read: 0	0	0	0	KBIE4	KBIE3	KBIE2	KBIE1
	Write: 	 	 	 	 	 	 	KBIE0
	Reset: 0	0	0	0	0	0	0	0

= Unimplemented

Figure 21-2. I/O Register Summary

Table 21-1-1. I/O Register Address Summary

Register	KBSCR	KBIER
Address	\$001A	\$001B

If the MODEK bit is set, the keyboard interrupt pins are both falling edge- and low level-sensitive, and both of the following actions must occur to clear a keyboard interrupt request:

- Vector fetch or software clear — A vector fetch generates an interrupt acknowledge signal to clear the interrupt request. Software may generate the interrupt acknowledge signal by writing a logic 1 to the ACKK bit in the keyboard status and control register (KBSCR). The ACKK bit is useful in applications that poll the keyboard interrupt pins and require software to clear the keyboard interrupt request. Writing to the ACKK bit prior to leaving an interrupt service routine also can prevent spurious interrupts due to noise. Setting ACKK does not affect subsequent transitions on the keyboard interrupt pins. A falling edge that occurs after writing to the ACKK bit latches another interrupt request. If the keyboard interrupt mask bit, IMASKK, is clear, the CPU loads the program counter with the vector address at locations \$FFDE and \$FFDF.
- Return of all enabled keyboard interrupt pins to logic 1. As long as any enabled keyboard interrupt pin is at logic 0, the keyboard interrupt remains set.

The vector fetch or software clear and the return of all enabled keyboard interrupt pins to logic 1 may occur in any order.

If the MODEK bit is clear, the keyboard interrupt pin is falling edge-sensitive only. With MODEK clear, a vector fetch or software clear immediately clears the keyboard interrupt request.

Reset clears the keyboard interrupt request and the MODEK bit, clearing the interrupt request even if a keyboard interrupt pin stays at logic 0.

The keyboard flag bit (KEYF) in the keyboard status and control register can be used to see if a pending interrupt exists. The KEYF bit is not affected by the keyboard interrupt mask bit (IMASKK) which makes it useful in applications where polling is preferred.

To determine the logic level on a keyboard interrupt pin, use the data direction register to configure the pin as an input and read the data register.

NOTE: *Setting a keyboard interrupt enable bit (KBIE_x) forces the corresponding keyboard interrupt pin to be an input, overriding the data direction register. However, the data direction register bit must be a logic 0 for software to read the pin.*

21.5 Keyboard Initialization

When a keyboard interrupt pin is enabled, it takes time for the internal pullup to reach a logic 1. Therefore, a false interrupt can occur as soon as the pin is enabled.

To prevent a false interrupt on keyboard initialization:

1. Mask keyboard interrupts by setting the IMASKK bit in the keyboard status and control register
2. Enable the KBI pins by setting the appropriate KBIE_x bits in the keyboard interrupt enable register
3. Write to the ACKK bit in the keyboard status and control register to clear any false interrupts
4. Clear the IMASKK bit.

An interrupt signal on an edge-triggered pin can be acknowledged immediately after enabling the pin. An interrupt signal on an edge- and level-triggered interrupt pin must be acknowledged after a delay that depends on the external load.

Another way to avoid a false interrupt:

1. Configure the keyboard pins as outputs by setting the appropriate DDRG bits in data direction register G.
2. Configure the keyboard pins as outputs by setting the appropriate DDRH bits in data direction register H.
3. Write logic 1s to the appropriate port G and port H data register bits.
4. Enable the KBI pins by setting the appropriate KBIE_x bits in the keyboard interrupt enable register.

21.6 Low-Power Modes

The WAIT and STOP instructions put the MCU in low-power-consumption standby modes.

21.6.1 Wait Mode

The keyboard module remains active in wait mode. Clearing the IMASKK bit in the keyboard status and control register enables keyboard interrupt requests to bring the MCU out of wait mode.

21.6.2 Stop Mode

The keyboard module remains active in stop mode. Clearing the IMASKK bit in the keyboard status and control register enables keyboard interrupt requests to bring the MCU out of stop mode.

21.7 Keyboard Module During Break Interrupts

The BCFE bit in the break flag control register (BFCR) enables software to clear status bits during the break state. See [Break Module \(BRK\)](#) on page 157.

To allow software to clear the KEYF bit during a break interrupt, write a logic 1 to the BCFE bit. If KEYF is cleared during the break state, it remains cleared when the MCU exits the break state.

To protect the KEYF bit during the break state, write a logic 0 to the BCFE bit. With BCFE at logic 0, writing to the keyboard acknowledge bit (ACKK) in the keyboard status and control register during the break state has no effect. See [Keyboard Status and Control Register](#) on page 329.

21.8 I/O Registers

The following registers control and monitor operation of the keyboard module:

- Keyboard status and control register (KBSCR)
- Keyboard interrupt enable register (KBIER)

21.8.1 Keyboard Status and Control Register

The keyboard status and control register:

- Flags keyboard interrupt requests
- Acknowledges keyboard interrupt requests
- Masks keyboard interrupt requests
- Controls keyboard interrupt triggering sensitivity

Address: \$001A

	Bit 7	6	5	4	3	2	1	Bit 0
Read:	0	0	0	0	KEYF	0	IMASKK	MODEK
Write:						ACKK		
Reset:	0	0	0	0	0	0	0	0

 = Unimplemented

Figure 21-3. Keyboard Status and Control Register (KBSCR)

Bits 7–4 — Not used

These read-only bits always read as logic 0s.

KEYF — Keyboard Flag Bit

This read-only bit is set when a keyboard interrupt is pending. Reset clears the KEYF bit.

1 = Keyboard interrupt pending

0 = No keyboard interrupt pending

ACKK — Keyboard Acknowledge Bit

Writing a logic 1 to this write-only bit clears the keyboard interrupt request. ACKK always reads as logic 0. Reset clears ACKK.

IMASKK — Keyboard Interrupt Mask Bit

Writing a logic 1 to this read/write bit prevents the output of the keyboard interrupt mask from generating interrupt requests. Reset clears the IMASKK bit.

- 1 = Keyboard interrupt requests masked
- 0 = Keyboard interrupt requests not masked

MODEK — Keyboard Triggering Sensitivity Bit

This read/write bit controls the triggering sensitivity of the keyboard interrupt pins. Reset clears MODEK.

- 1 = Keyboard interrupt requests on falling edges and low levels
- 0 = Keyboard interrupt requests on falling edges only

21.8.2 Keyboard Interrupt Enable Register

The keyboard interrupt enable register enables or disables each port G and each port H pin to operate as a keyboard interrupt pin.

Address: \$001B

	Bit 7	6	5	4	3	2	1	Bit 0
Read:	0	0	0	KBIE4	KBIE3	KBIE2	KBIE1	KBIE0
Write:								
Reset:	0	0	0	0	0	0	0	0

= Unimplemented

Figure 21-4. Keyboard Interrupt Enable Register (KBIE)

KBIE4–KBIE0 — Keyboard Interrupt Enable Bits

Each of these read/write bits enables the corresponding keyboard interrupt pin to latch interrupt requests. Reset clears the keyboard interrupt enable register.

- 1 = PDx pin enabled as keyboard interrupt pin
- 0 = PDx pin not enabled as keyboard interrupt pin

Section 22. Timer Interface Module A (TIMA)

22.1 Contents

22.2	Introduction	332
22.3	Features	332
22.4	Functional Description	335
22.4.1	TIMA Counter Prescaler	335
22.4.2	Input Capture	335
22.4.3	Output Compare	337
22.4.3.1	Unbuffered Output Compare	337
22.4.3.2	Buffered Output Compare	338
22.4.4	Pulse Width Modulation (PWM)	339
22.4.4.1	Unbuffered PWM Signal Generation	340
22.4.4.2	Buffered PWM Signal Generation	341
22.4.4.3	PWM Initialization	343
22.5	Interrupts	344
22.6	Low-Power Modes	345
22.6.1	Wait Mode	345
22.6.2	Stop Mode	345
22.7	TIMA During Break Interrupts	345
22.8	I/O Signals	346
22.8.1	TIMA Clock Pin (PTD6/ATD14/ TACLK)	346
22.8.2	TIMA Channel I/O Pins (PTF3–PTF0/TACH2 and PTE3/TACH1–PTE2/TACH0)	346
22.9	I/O Registers	347
22.9.1	TIMA Status and Control Register	347
22.9.2	TIMA Counter Registers	349
22.9.3	TIMA Counter Modulo Registers	351
22.9.4	TIMA Channel Status and Control Registers	352
22.9.5	TIMA Channel Registers	357

22.2 Introduction

This section describes the timer interface module (TIMA). The TIMA is a 6-channel timer that provides a timing reference with input capture, output compare and pulse-width-modulation functions. [Figure 22-1](#) is a block diagram of the TIMA.

For further information regarding timers on M68HC08 family devices, please consult the HC08 Timer Reference Manual, TIM08RM/AD.

22.3 Features

Features of the TIMA include:

- Six Input Capture/Output Compare Channels
 - Rising-Edge, Falling-Edge or Any-Edge Input Capture Trigger
 - Set, Clear or Toggle Output Compare Action
- Buffered and Unbuffered Pulse Width Modulation (PWM) Signal Generation
- Programmable TIMA Clock Input
 - 7 Frequency Internal Bus Clock Prescaler Selection
 - External TIMA Clock Input (4 MHz Maximum Frequency)
- Free-Running or Modulo Up-Count Operation
- Toggle Any Channel Pin on Overflow
- TIMA Counter Stop and Reset Bits

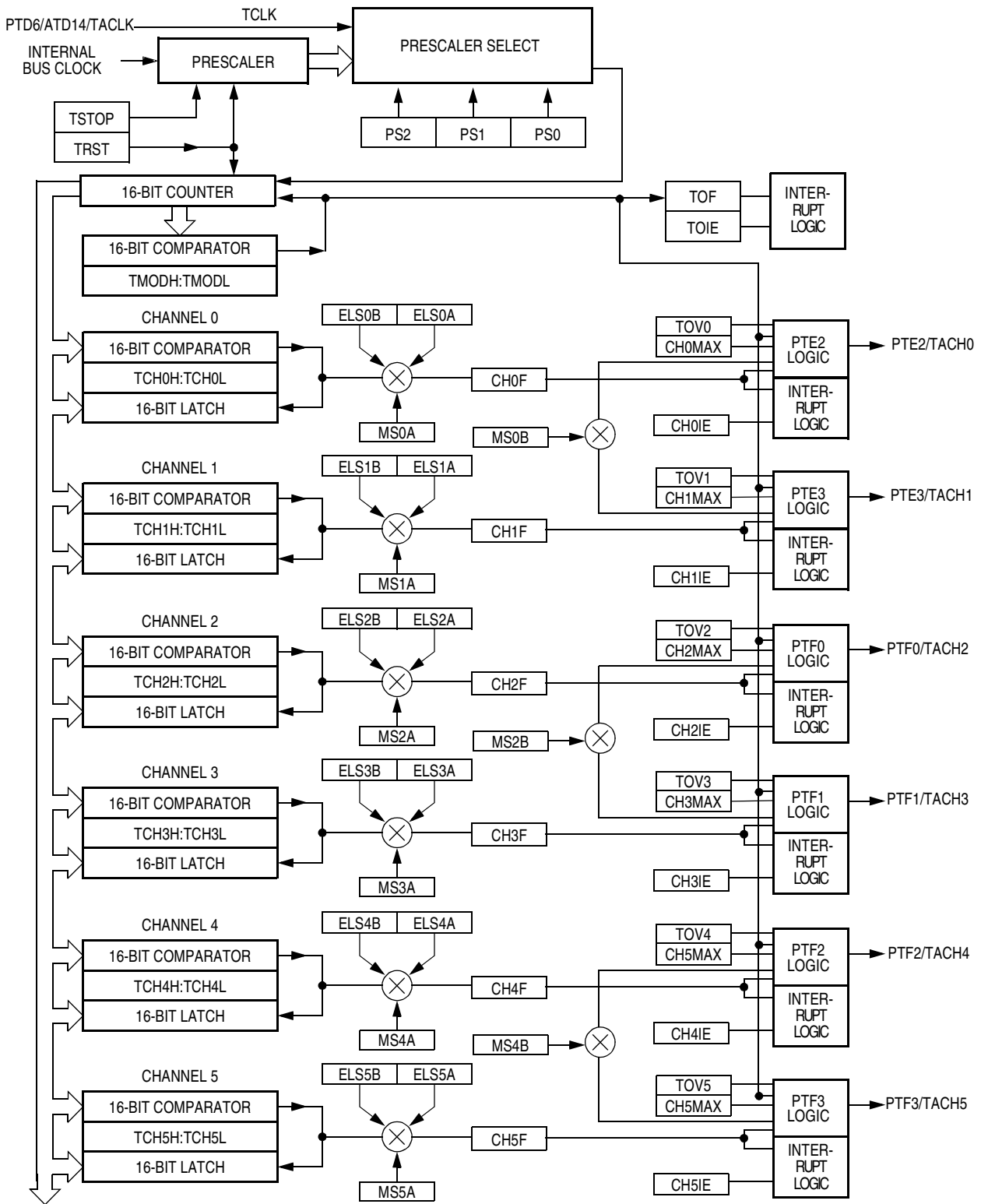

Figure 22-1. TIMA Block Diagram

Figure 22-2. TIMA I/O Register Summary

Addr.	Register Name	Bit 7	6	5	4	3	2	1	Bit 0
\$0020	TIMA Status/Control Register (TASC)	TOF	TOIE	TSTOP	TRST	0	PS2	PS1	PS0
\$0021	Reserved	R	R	R	R	R	R	R	R
\$0022	TIMA Counter Register High (TACNTH)	Bit 15	14	13	12	11	10	9	Bit 8
\$0023	TIMA Counter Register Low (TACNTL)	Bit 7	6	5	4	3	2	1	Bit 0
\$0024	TIMA Counter Modulo Reg. High (TAMODH)	Bit 15	14	13	12	11	10	9	Bit 8
\$0025	TIMA Counter Modulo Reg. Low (TAMODL)	Bit 7	6	5	4	3	2	1	Bit 0
\$0026	TIMA Ch. 0 Status/Control Register (TASC0)	CH0F	CH0IE	MS0B	MS0A	ELS0B	ELS0A	TOV0	CH0MAX
\$0027	TIMA Ch. 0 Register High (TACH0H)	Bit 15	14	13	12	11	10	9	Bit 8
\$0028	TIMA Ch. 0 Register Low (TACH0L)	Bit 7	6	5	4	3	2	1	Bit 0
\$0029	TIMA Ch. 1 Status/Control Register (TASC1)	CH1F	CH1IE	0	MS1A	ELS1B	ELS1A	TOV1	CH1MAX
\$002A	TIMA Ch. 1 Register High (TACH1H)	Bit 15	14	13	12	11	10	9	Bit 8
\$002B	TIMA Ch. 1 Register Low (TACH1L)	Bit 7	6	5	4	3	2	1	Bit 0
\$002C	TIMA Ch. 2 Status/Control Register (TASC2)	CH2F	CH2IE	MS2B	MS2A	ELS2B	ELS2A	TOV2	CH2MAX
\$002D	TIMA Ch. 2 Register High (TACH2H)	Bit 15	14	13	12	11	10	9	Bit 8
\$002E	TIMA Ch. 2 Register Low (TACH2L)	Bit 7	6	5	4	3	2	1	Bit 0
\$002F	TIMA Ch. 3 Status/Control Register (TASC3)	CH3F	CH3IE	0	MS3A	ELS3B	ELS3A	TOV3	CH3MAX
\$0030	TIMA Ch. 3 Register High (TACH3H)	Bit 15	14	13	12	11	10	9	Bit 8
\$0031	TIMA Ch. 3 Register Low (TACH3L)	Bit 7	6	5	4	3	2	1	Bit 0
\$0032	TIMA Ch. 4 Status/Control Register (TASC4)	CH4F	CH4IE	MS4B	MS4A	ELS4B	ELS4A	TOV4	CH4MAX
\$0033	TIMA Ch. 4 Register High (TACH4H)	Bit 15	14	13	12	11	10	9	Bit 8
\$0034	TIMA Ch. 4 Register Low (TACH4L)	Bit 7	6	5	4	3	2	1	Bit 0
\$0035	TIMA Ch. 5 Status/Control Register (TASC5)	CH5F	CH5IE	0	MS5A	ELS5B	ELS5A	TOV5	CH5MAX
\$0036	TIMA Ch. 5 Register High (TACH5H)	Bit 15	14	13	12	11	10	9	Bit 8
\$0037	TIMA Ch. 5 Register Low (TACH5L)	Bit 7	6	5	4	3	2	1	Bit 0

R = Reserved

22.4 Functional Description

Figure 22-1 shows the TIMA structure. The central component of the TIMA is the 16-bit TIMA counter that can operate as a free-running counter or a modulo up-counter. The TIMA counter provides the timing reference for the input capture and output compare functions. The TIMA counter modulo registers, TAMODH–TAMODL, control the modulo value of the TIMA counter. Software can read the TIMA counter value at any time without affecting the counting sequence.

The six TIMA channels are programmable independently as input capture or output compare channels.

22.4.1 TIMA Counter Prescaler

The TIMA clock source can be one of the seven prescaler outputs or the TIMA clock pin, PTD6/ATD14/TACLK. The prescaler generates seven clock rates from the internal bus clock. The prescaler select bits, PS[2:0], in the TIMA status and control register select the TIMA clock source.

22.4.2 Input Capture

An input capture function has three basic parts: edge select logic, an input capture latch and a 16-bit counter. Two 8-bit registers, which make up the 16-bit input capture register, are used to latch the value of the free-running counter after the corresponding input capture edge detector senses a defined transition. The polarity of the active edge is programmable. The level transition which triggers the counter transfer is defined by the corresponding input edge bits (ELSxB and ELSxA in TASC0 through TASC5 control registers with x referring to the active channel number). When an active edge occurs on the pin of an input capture channel, the TIMA latches the contents of the TIMA counter into the TIMA channel registers, TACHxH–TACHxL. Input captures can generate TIMA CPU interrupt requests. Software can determine that an input capture event has occurred by enabling input capture interrupts or by polling the status flag bit.

The free-running counter contents are transferred to the TIMA channel register (TACHxH–TACHxL see [TIMA Channel Registers](#) on page 357) on each proper signal transition regardless of whether the TIMA channel flag (CH0F–CH5F in TASC0–TASC5 registers) is set or clear. When the status flag is set, a CPU interrupt is generated if enabled. The value of the count latched or “captured” is the time of the event. Because this value is stored in the input capture register 2 bus cycles after the actual event occurs, user software can respond to this event at a later time and determine the actual time of the event. However, this must be done prior to another input capture on the same pin; otherwise, the previous time value will be lost.

By recording the times for successive edges on an incoming signal, software can determine the period and/or pulse width of the signal. To measure a period, two successive edges of the same polarity are captured. To measure a pulse width, two alternate polarity edges are captured. Software should track the overflows at the 16-bit module counter to extend its range.

Another use for the input capture function is to establish a time reference. In this case, an input capture function is used in conjunction with an output compare function. For example, to activate an output signal a specified number of clock cycles after detecting an input event (edge), use the input capture function to record the time at which the edge occurred. A number corresponding to the desired delay is added to this captured value and stored to an output compare register (see [TIMA Channel Registers](#) on page 357). Because both input captures and output compares are referenced to the same 16-bit modulo counter, the delay can be controlled to the resolution of the counter independent of software latencies.

Reset does not affect the contents of the TIMA channel register (TACHxH–TACHxL).

22.4.3 Output Compare

With the output compare function, the TIMA can generate a periodic pulse with a programmable polarity, duration and frequency. When the counter reaches the value in the registers of an output compare channel, the TIMA can set, clear or toggle the channel pin. Output compares can generate TIMA CPU interrupt requests.

22.4.3.1 Unbuffered Output Compare

Any output compare channel can generate unbuffered output compare pulses as described in [Output Compare](#) on page 337. The pulses are unbuffered because changing the output compare value requires writing the new value over the old value currently in the TIMA channel registers.

An unsynchronized write to the TIMA channel registers to change an output compare value could cause incorrect operation for up to two counter overflow periods. For example, writing a new value before the counter reaches the old value but after the counter reaches the new value prevents any compare during that counter overflow period. Also, using a TIMA overflow interrupt routine to write a new, smaller output compare value may cause the compare to be missed. The TIMA may pass the new value before it is written.

Use the following methods to synchronize unbuffered changes in the output compare value on channel x:

- When changing to a smaller value, enable channel x output compare interrupts and write the new value in the output compare interrupt routine. The output compare interrupt occurs at the end of the current output compare pulse. The interrupt routine has until the end of the counter overflow period to write the new value.
- When changing to a larger output compare value, enable TIMA overflow interrupts and write the new value in the TIMA overflow interrupt routine. The TIMA overflow interrupt occurs at the end of the current counter overflow period. Writing a larger value in an output compare interrupt routine (at the end of the current pulse) could cause two output compares to occur in the same counter overflow period.

22.4.3.2 Buffered Output Compare

Channels 0 and 1 can be linked to form a buffered output compare channel whose output appears on the PTE2/TACH0 pin. The TIMA channel registers of the linked pair alternately control the output.

Setting the MS0B bit in TIMA channel 0 status and control register (TASC0) links channel 0 and channel 1. The output compare value in the TIMA channel 0 registers initially controls the output on the PTE2/TACH0 pin. Writing to the TIMA channel 1 registers enables the TIMA channel 1 registers to synchronously control the output after the TIMA overflows. At each subsequent overflow, the TIMA channel registers (0 or 1) that control the output are the ones written to last. TASC0 controls and monitors the buffered output compare function and TIMA channel 1 status and control register (TASC1) is unused. While the MS0B bit is set, the channel 1 pin, PTE3/TACH1, is available as a general-purpose I/O pin.

Channels 2 and 3 can be linked to form a buffered output compare channel whose output appears on the PTF0/TACH2 pin. The TIMA channel registers of the linked pair alternately control the output.

Setting the MS2B bit in TIMA channel 2 status and control register (TASC2) links channel 2 and channel 3. The output compare value in the TIMA channel 2 registers initially controls the output on the PTF0/TACH2 pin. Writing to the TIMA channel 3 registers enables the TIMA channel 3 registers to synchronously control the output after the TIMA overflows. At each subsequent overflow, the TIMA channel registers (2 or 3) that control the output are the ones written to last. TASC2 controls and monitors the buffered output compare function, and TIMA channel 3 status and control register (TASC3) is unused. While the MS2B bit is set, the channel 3 pin, PTF1/TACH3, is available as a general-purpose I/O pin.

Channels 4 and 5 can be linked to form a buffered output compare channel whose output appears on the PTF2 pin. The TIMA channel registers of the linked pair alternately control the output.

Setting the MS4B bit in TIMA channel 4 status and control register (TASC4) links channel 4 and channel 5. The output compare value in the

TIMA channel 4 registers initially controls the output on the PTF2 pin. Writing to the TIMA channel 5 registers enables the TIMA channel 5 registers to synchronously control the output after the TIMA overflows. At each subsequent overflow, the TIMA channel registers (4 or 5) that control the output are the ones written to last. TASC4 controls and monitors the buffered output compare function and TIMA channel 5 status and control register (TASC5) is unused. While the MS4B bit is set, the channel 5 pin, PTF3, is available as a general-purpose I/O pin.

NOTE: *In buffered output compare operation, do not write new output compare values to the currently active channel registers. User software should track the currently active channel to prevent writing a new value to the active channel. Writing to the active channel registers is the same as generating unbuffered output compares.*

22.4.4 Pulse Width Modulation (PWM)

By using the toggle-on-overflow feature with an output compare channel, the TIMA can generate a PWM signal. The value in the TIMA counter modulo registers determines the period of the PWM signal. The channel pin toggles when the counter reaches the value in the TIMA counter modulo registers. The time between overflows is the period of the PWM signal.

As [Figure 22-3](#) shows, the output compare value in the TIMA channel registers determines the pulse width of the PWM signal. The time between overflow and output compare is the pulse width. Program the TIMA to clear the channel pin on output compare if the state of the PWM pulse is logic 1. Program the TIMA to set the pin if the state of the PWM pulse is logic 0.

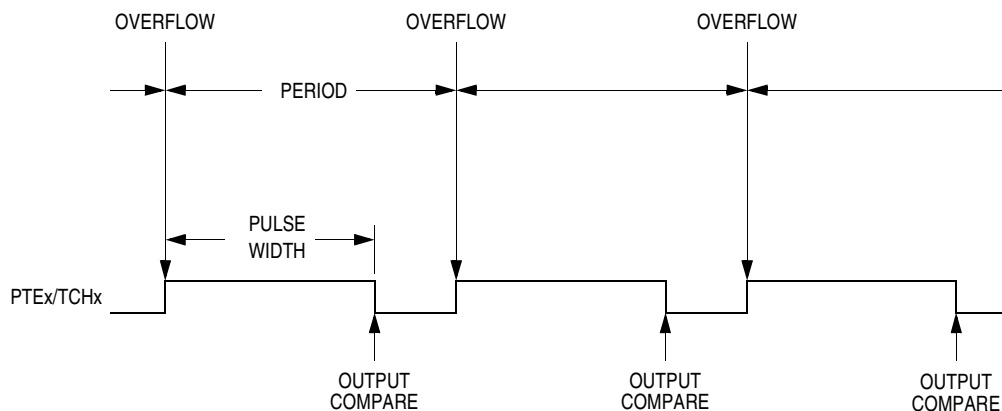

Figure 22-3. PWM Period and Pulse Width

The value in the TIMA counter modulo registers and the selected prescaler output determines the frequency of the PWM output. The frequency of an 8-bit PWM signal is variable in 256 increments. Writing \$00FF (255) to the TIMA counter modulo registers produces a PWM period of 256 times the internal bus clock period if the prescaler select value is \$000 (see [TIMA Status and Control Register](#) on page 347).

The value in the TIMA channel registers determines the pulse width of the PWM output. The pulse width of an 8-bit PWM signal is variable in 256 increments. Writing \$0080 (128) to the TIMA channel registers produces a duty cycle of 128/256 or 50%.

22.4.4.1 Unbuffered PWM Signal Generation

Any output compare channel can generate unbuffered PWM pulses as described in [Pulse Width Modulation \(PWM\)](#) on page 339. The pulses are unbuffered because changing the pulse width requires writing the new pulse width value over the value currently in the TIMA channel registers.

An unsynchronized write to the TIMA channel registers to change a pulse width value could cause incorrect operation for up to two PWM periods. For example, writing a new value before the counter reaches the old value but after the counter reaches the new value prevents any compare during that PWM period. Also, using a TIMA overflow interrupt routine to write a new, smaller pulse width value may cause the compare

to be missed. The TIMA may pass the new value before it is written to the TIMA channel registers.

Use the following methods to synchronize unbuffered changes in the PWM pulse width on channel x:

- When changing to a shorter pulse width, enable channel x output compare interrupts and write the new value in the output compare interrupt routine. The output compare interrupt occurs at the end of the current pulse. The interrupt routine has until the end of the PWM period to write the new value.
- When changing to a longer pulse width, enable TIMA overflow interrupts and write the new value in the TIMA overflow interrupt routine. The TIMA overflow interrupt occurs at the end of the current PWM period. Writing a larger value in an output compare interrupt routine (at the end of the current pulse) could cause two output compares to occur in the same PWM period.

NOTE: *In PWM signal generation, do not program the PWM channel to toggle on output compare. Toggling on output compare prevents reliable 0% duty cycle generation and removes the ability of the channel to self-correct in the event of software error or noise. Toggling on output compare also can cause incorrect PWM signal generation when changing the PWM pulse width to a new, much larger value.*

22.4.4.2 Buffered PWM Signal Generation

Channels 0 and 1 can be linked to form a buffered PWM channel whose output appears on the PTE2/TACH0 pin. The TIMA channel registers of the linked pair alternately control the pulse width of the output.

Setting the MS0B bit in TIMA channel 0 status and control register (TASC0) links channel 0 and channel 1. The TIMA channel 0 registers initially control the pulse width on the PTE2/TACH0 pin. Writing to the TIMA channel 1 registers enables the TIMA channel 1 registers to synchronously control the pulse width at the beginning of the next PWM period. At each subsequent overflow, the TIMA channel registers (0 or 1) that control the pulse width are the ones written to last. TASC0 controls and monitors the buffered PWM function and TIMA channel 1

status and control register (TASC1) is unused. While the MS0B bit is set, the channel 1 pin, PTE3/TACH1, is available as a general-purpose I/O pin.

Channels 2 and 3 can be linked to form a buffered PWM channel whose output appears on the PTF0/TACH2 pin. The TIMA channel registers of the linked pair alternately control the pulse width of the output.

Setting the MS2B bit in TIMA channel 2 status and control register (TASC2) links channel 2 and channel 3. The TIMA channel 2 registers initially control the pulse width on the PTF0/TACH2 pin. Writing to the TIMA channel 3 registers enables the TIMA channel 3 registers to synchronously control the pulse width at the beginning of the next PWM period. At each subsequent overflow, the TIMA channel registers (2 or 3) that control the pulse width are the ones written to last. TASC2 controls and monitors the buffered PWM function and TIMA channel 3 status and control register (TASC3) is unused. While the MS2B bit is set, the channel 3 pin, PTF1/TACH3, is available as a general-purpose I/O pin.

Channels 4 and 5 can be linked to form a buffered PWM channel whose output appears on the PTF2 pin. The TIMA channel registers of the linked pair alternately control the pulse width of the output.

Setting the MS4B bit in TIMA channel 4 status and control register (TASC4) links channel 4 and channel 5. The TIMA channel 4 registers initially control the pulse width on the PTF2 pin. Writing to the TIMA channel 5 registers enables the TIMA channel 5 registers to synchronously control the pulse width at the beginning of the next PWM period. At each subsequent overflow, the TIMA channel registers (4 or 5) that control the pulse width are the ones written to last. TASC4 controls and monitors the buffered PWM function and TIMA channel 5 status and control register (TASC5) is unused. While the MS4B bit is set, the channel 5 pin, PTF3, is available as a general-purpose I/O pin.

NOTE: *In buffered PWM signal generation, do not write new pulse width values to the currently active channel registers. User software should track the currently active channel to prevent writing a new value to the active channel. Writing to the active channel registers is the same as generating unbuffered PWM signals.*

22.4.4.3 PWM Initialization

To ensure correct operation when generating unbuffered or buffered PWM signals, use the following initialization procedure:

1. In the TIMA status and control register (TASC):
 - a. Stop the TIMA counter by setting the TIMA stop bit, TSTOP.
 - b. Reset the TIMA counter and prescaler by setting the TIMA reset bit, TRST.
2. In the TIMA counter modulo registers (TAMODH–TAMODL) write the value for the required PWM period.
3. In the TIMA channel x registers (TACHxH–TACHxL) write the value for the required pulse width.
4. In TIMA channel x status and control register (TASCx):
 - a. Write 0:1 (for unbuffered output compare or PWM signals) or 1:0 (for buffered output compare or PWM signals) to the mode select bits, MSxB–MSxA (see [Table 22-2](#)).
 - b. Write 1 to the toggle-on-overflow bit, TOVx.
 - c. Write 1:0 (to clear output on compare) or 1:1 (to set output on compare) to the edge/level select bits, ELSxB–ELSxA. The output action on compare must force the output to the complement of the pulse width level (see [Table 22-2](#)).

NOTE: *In PWM signal generation, do not program the PWM channel to toggle on output compare. Toggling on output compare prevents reliable 0% duty cycle generation and removes the ability of the channel to self-correct in the event of software error or noise. Toggling on output compare can also cause incorrect PWM signal generation when changing the PWM pulse width to a new, much larger value.*

5. In the TIMA status control register (TASC) clear the TIMA stop bit, TSTOP.

Setting MS0B links channels 0 and 1 and configures them for buffered PWM operation. The TIMA channel 0 registers (TACH0H–TACH0L) initially control the buffered PWM output. TIMA status control register 0

(TASC0) controls and monitors the PWM signal from the linked channels. MS0B takes priority over MS0A.

Setting MS2B links channels 2 and 3 and configures them for buffered PWM operation. The TIMA channel 2 registers (TACH2H–TACH2L) initially control the buffered PWM output. TIMA status control register 2 (TASC2) controls and monitors the PWM signal from the linked channels. MS2B takes priority over MS2A.

Setting MS4B links channels 4 and 5 and configures them for buffered PWM operation. The TIMA channel 4 registers (TACH4H–TACH4L) initially control the buffered PWM output. TIMA status control register 4 (TASC4) controls and monitors the PWM signal from the linked channels. MS4B takes priority over MS4A.

Clearing the toggle-on-overflow bit, TOVx, inhibits output toggles on TIMA overflows. Subsequent output compares try to force the output to a state it is already in and have no effect. The result is a 0% duty cycle output.

Setting the channel x maximum duty cycle bit (CHxMAX) and setting the TOVx bit generates a 100% duty cycle output (see [TIMA Channel Status and Control Registers](#) on page 352).

22.5 Interrupts

The following TIMA sources can generate interrupt requests:

- TIMA overflow flag (TOF) — The TOF bit is set when the TIMA counter reaches the modulo value programmed in the TIMA counter modulo registers. The TIMA overflow interrupt enable bit, TOIE, enables TIMA overflow CPU interrupt requests. TOF and TOIE are in the TIMA status and control register.
- TIMA channel flags (CH5F–CH0F) — The CHxF bit is set when an input capture or output compare occurs on channel x. Channel x TIMA CPU interrupt requests are controlled by the channel x interrupt enable bit, CHxIE.

22.6 Low-Power Modes

The WAIT and STOP instructions put the MCU in low power-consumption standby modes.

22.6.1 Wait Mode

The TIMA remains active after the execution of a WAIT instruction. In wait mode, the TIMA registers are not accessible by the CPU. Any enabled CPU interrupt request from the TIMA can bring the MCU out of wait mode.

If TIMA functions are not required during wait mode, reduce power consumption by stopping the TIMA before executing the WAIT instruction.

22.6.2 Stop Mode

The TIMA is inactive after the execution of a STOP instruction. The STOP instruction does not affect register conditions or the state of the TIMA counter. TIMA operation resumes when the MCU exits stop mode.

22.7 TIMA During Break Interrupts

A break interrupt stops the TIMA counter and inhibits input captures.

The system integration module (SIM) controls whether status bits in other modules can be cleared during the break state. The BCFE bit in the SIM break flag control register (SBFCR) enables software to clear status bits during the break state (see [SIM Break Flag Control Register](#) on page 122).

To allow software to clear status bits during a break interrupt, write a logic 1 to the BCFE bit. If a status bit is cleared during the break state, it remains cleared when the MCU exits the break state.

To protect status bits during the break state, write a logic 0 to the BCFE bit. With BCFE at logic 0 (its default state), software can read and write I/O registers during the break state without affecting status bits. Some

status bits have a 2-step read/write clearing procedure. If software does the first step on such a bit before the break, the bit cannot change during the break state as long as BCFE is at logic 0. After the break, doing the second step clears the status bit.

22.8 I/O Signals

Port D shares one of its pins with the TIMA. Port E shares two of its pins with the TIMA and port F shares four of its pins with the TIMA.

PTD6/ATD14/TACLK is an external clock input to the TIMA prescaler.

The six TIMA channel I/O pins are PTE2/TACH0, PTE3/TACH1, PTF0/TACH2, PTF1/TACH3, PTF2, and PTF3.

22.8.1 TIMA Clock Pin (PTD6/ATD14/TACLK)

PTD6/ATD14/TACLK is an external clock input that can be the clock source for the TIMA counter instead of the prescaled internal bus clock. Select the PTD6/ATD14/TACLK input by writing logic 1s to the three prescaler select bits, PS[2:0] (see [TIMA Status and Control Register](#)). The minimum TCLK pulse width, $TCLK_{L\text{MIN}}$ or $TCLK_{H\text{MIN}}$, is:

$$\frac{1}{\text{bus frequency}} + t_{\text{SU}}$$

The maximum TCLK frequency is the least: 4 MHz or bus frequency $\div 2$.

PTD6/ATD14/TACLK is available as a general-purpose I/O pin or ADC channel when not used as the TIMA clock input. When the PTD6/ATD14/TACLK pin is the TIMA clock input, it is an input regardless of the state of the DDRD6 bit in data direction register D.

22.8.2 TIMA Channel I/O Pins (PTF3–PTF0/TACH2 and PTE3/TACH1–PTE2/TACH0)

Each channel I/O pin is programmable independently as an input capture pin or an output compare pin. PTE2/TACH0, PTF0/TACH2 and PTF2 can be configured as buffered output compare or buffered PWM pins.

22.9 I/O Registers

These I/O registers control and monitor TIMA operation:

- TIMA status and control register (TASC)
- TIMA control registers (TACNTH–TACNTL)
- TIMA counter modulo registers (TAMODH–TAMODL)
- TIMA channel status and control registers (TASC0, TASC1, TASC2, TASC3, TASC4 and TASC5)
- TIMA channel registers (TACH0H–TACH0L, TACH1H–TACH1L, TACH2H–TACH2L, TACH3H–TACH3L, TACH4H–TACH4L and TACH5H–TACH5L)

22.9.1 TIMA Status and Control Register

The TIMA status and control register:

- Enables TIMA overflow interrupts
- Flags TIMA overflows
- Stops the TIMA counter
- Resets the TIMA counter
- Prescales the TIMA counter clock

Address: \$0020

	Bit 7	6	5	4	3	2	1	Bit 0
Read:	TOF	TOIE	TSTOP	0	0	PS2	PS1	PS0
Write:	0			TRST	R			
Reset:	0	0	1	0	0	0	0	0

R = Reserved

Figure 22-4. TIMA Status and Control Register (TASC)

TOF — TIMA Overflow Flag Bit

This read/write flag is set when the TIMA counter reaches the modulo value programmed in the TIMA counter modulo registers. Clear TOF by reading the TIMA status and control register when TOF is set and then writing a logic 0 to TOF. If another TIMA overflow occurs before the clearing sequence is complete, then writing logic 0 to TOF has no effect. Therefore, a TOF interrupt request cannot be lost due to inadvertent clearing of TOF. Reset clears the TOF bit. Writing a logic 1 to TOF has no effect.

1 = TIMA counter has reached modulo value.

0 = TIMA counter has not reached modulo value.

TOIE — TIMA Overflow Interrupt Enable Bit

This read/write bit enables TIMA overflow interrupts when the TOF bit becomes set. Reset clears the TOIE bit.

1 = TIMA overflow interrupts enabled

0 = TIMA overflow interrupts disabled

TSTOP — TIMA Stop Bit

This read/write bit stops the TIMA counter. Counting resumes when TSTOP is cleared. Reset sets the TSTOP bit, stopping the TIMA counter until software clears the TSTOP bit.

1 = TIMA counter stopped

0 = TIMA counter active

NOTE: *Do not set the TSTOP bit before entering wait mode if the TIMA is required to exit wait mode. Also, when the TSTOP bit is set and input capture mode is enabled, input captures are inhibited until TSTOP is cleared.*

TRST — TIMA Reset Bit

Setting this write-only bit resets the TIMA counter and the TIMA prescaler. Setting TRST has no effect on any other registers. Counting resumes from \$0000. TRST is cleared automatically after the TIMA counter is reset and always reads as logic 0. Reset clears the TRST bit.

1 = Prescaler and TIMA counter cleared

0 = No effect

NOTE: *Setting the TSTOP and TRST bits simultaneously stops the TIMA counter at a value of \$0000.*

PS[2:0] — Prescaler Select Bits

These read/write bits select either the PTD6/ATD14/TACLK pin or one of the seven prescaler outputs as the input to the TIMA counter as **Table 22-1** shows. Reset clears the PS[2:0] bits.

Table 22-1. Prescaler Selection

PS[2:0]	TIMA Clock Source
000	Internal Bus Clock ÷ 1
001	Internal Bus Clock ÷ 2
010	Internal Bus Clock ÷ 4
011	Internal Bus Clock ÷ 8
100	Internal Bus Clock ÷ 16
101	Internal Bus Clock ÷ 32
110	Internal Bus Clock ÷ 64
111	PTD6/ATD14/TACLK

22.9.2 TIMA Counter Registers

The two read-only TIMA counter registers contain the high and low bytes of the value in the TIMA counter. Reading the high byte (TACNTH) latches the contents of the low byte (TACNTL) into a buffer. Subsequent reads of TACNTH do not affect the latched TACNTL value until TACNTL is read. Reset clears the TIMA counter registers. Setting the TIMA reset bit (TRST) also clears the TIMA counter registers.

NOTE: *If TACNTH is read during a break interrupt, be sure to unlatch TACNTL by reading TACNTL before exiting the break interrupt. Otherwise, TACNTL retains the value latched during the break.*

Timer Interface Module A (TIMA)

Register Name and Address TACNTH — \$0022

	Bit 7	6	5	4	3	2	1	Bit 0
Read:	BIT 15	BIT 14	BIT 13	BIT 12	BIT 11	BIT 10	BIT 9	BIT 8
Write:	R	R	R	R	R	R	R	R
Reset:	0	0	0	0	0	0	0	0

Register Name and Address TACNTL — \$0023

	Bit 7	6	5	4	3	2	1	Bit 0
Read:	BIT 7	BIT 6	BIT 5	BIT 4	BIT 3	BIT 2	BIT 1	BIT 0
Write:	R	R	R	R	R	R	R	R
Reset:	0	0	0	0	0	0	0	0

R

 = Reserved

Figure 22-5. TIMA Counter Registers (TACNTH and TACNTL)

22.9.3 TIMA Counter Modulo Registers

The read/write TIMA modulo registers contain the modulo value for the TIMA counter. When the TIMA counter reaches the modulo value, the overflow flag (TOF) becomes set and the TIMA counter resumes counting from \$0000 at the next timer clock. Writing to the high byte (TAMODH) inhibits the TOF bit and overflow interrupts until the low byte (TAMODL) is written. Reset sets the TIMA counter modulo registers.

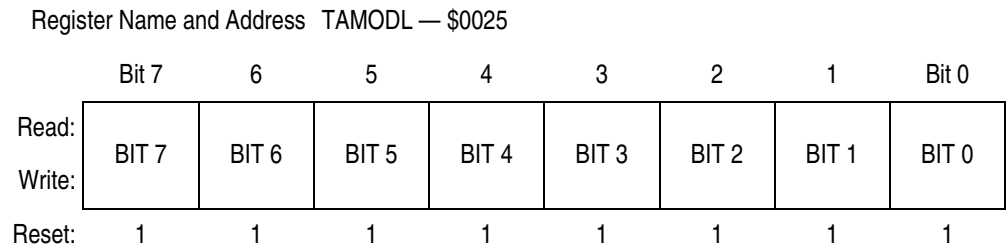
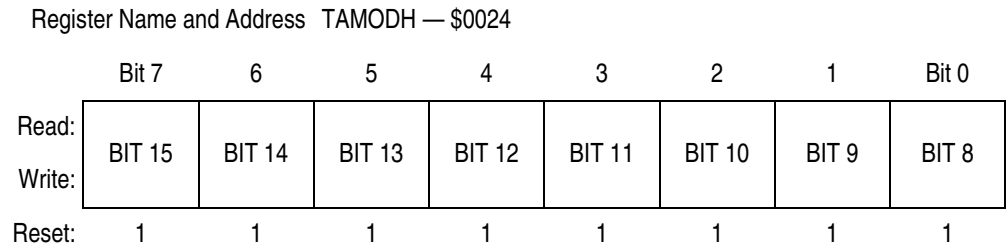

Figure 22-6. TIMA Counter Modulo Registers (TAMODH and TAMODL)

NOTE: *Reset the TIMA counter before writing to the TIMA counter modulo registers.*

22.9.4 TIMA Channel Status and Control Registers

Each of the TIMA channel status and control registers:

- Flags input captures and output compares
- Enables input capture and output compare interrupts
- Selects input capture, output compare or PWM operation
- Selects high, low or toggling output on output compare
- Selects rising edge, falling edge or any edge as the active input capture trigger
- Selects output toggling on TIMA overflow
- Selects 0% and 100% PWM duty cycle
- Selects buffered or unbuffered output compare/PWM operation

Register Name and Address TASC0 — \$0026

	Bit 7	6	5	4	3	2	1	Bit 0
Read:	CH0F	CH0IE	MS0B	MS0A	ELS0B	ELS0A	TOV0	CH0MAX
Write:	0		0	0	0	0	0	0
Reset:	0	0	0	0	0	0	0	0

Register Name and Address TASC1 — \$0029

	Bit 7	6	5	4	3	2	1	Bit 0
Read:	CH1F	CH1IE	0	MS1A	ELS1B	ELS1A	TOV1	CH1MAX
Write:	0		R	0	0	0	0	0
Reset:	0	0	0	0	0	0	0	0

R

 = Reserved

Figure 22-7. TIMA Channel Status and Control Registers (TASC0–TASC5)

Register Name and Address TASC2 — \$002C

	Bit 7	6	5	4	3	2	1	Bit 0
Read:	CH2F	CH2IE	MS2B	MS2A	ELS2B	ELS2A	TOV2	CH2MAX
Write:	0							
Reset:	0	0	0	0	0	0	0	0

Register Name and Address TASC3 — \$002F

	Bit 7	6	5	4	3	2	1	Bit 0
Read:	CH3F	CH3IE	0	MS3A	ELS3B	ELS3A	TOV3	CH3MAX
Write:	0		R					
Reset:	0	0	0	0	0	0	0	0

Register Name and Address TASC4 — \$0032

	Bit 7	6	5	4	3	2	1	Bit 0
Read:	CH4F	CH4IE	MS4B	MS4A	ELS4B	ELS4A	TOV4	CH4MAX
Write:	0							
Reset:	0	0	0	0	0	0	0	0

Register Name and Address TASC5 — \$0035

	Bit 7	6	5	4	3	2	1	Bit 0
Read:	CH5F	CH5IE	0	MS5A	ELS5B	ELS5A	TOV5	CH5MAX
Write:	0		R					
Reset:	0	0	0	0	0	0	0	0

R

 = Reserved

Figure 22-7. TIMA Channel Status and Control Registers (TASC0–TASC5) (Continued)

CHxF — Channel x Flag Bit

When channel x is an input capture channel, this read/write bit is set when an active edge occurs on the channel x pin. When channel x is an output compare channel, CHxF is set when the value in the TIMA counter registers matches the value in the TIMA channel x registers.

When CHxIE = 1, clear CHxF by reading TIMA channel x status and control register with CHxF set and then writing a logic 0 to CHxF. If another interrupt request occurs before the clearing sequence is complete, then writing logic 0 to CHxF has no effect. Therefore, an interrupt request cannot be lost due to inadvertent clearing of CHxF.

Reset clears the CHxF bit. Writing a logic 1 to CHxF has no effect.

- 1 = Input capture or output compare on channel x
- 0 = No input capture or output compare on channel x

CHxIE — Channel x Interrupt Enable Bit

This read/write bit enables TIMA CPU interrupts on channel x.

Reset clears the CHxIE bit.

- 1 = Channel x CPU interrupt requests enabled
- 0 = Channel x CPU interrupt requests disabled

MSxB — Mode Select Bit B

This read/write bit selects buffered output compare/PWM operation. MSxB exists only in the TIMA channel 0, TIMA channel 2 and TIMA channel 4 status and control registers.

Setting MS0B disables the channel 1 status and control register and reverts TACH1 pin to general-purpose I/O.

Setting MS2B disables the channel 3 status and control register and reverts TACH3 pin to general-purpose I/O.

Setting MS4B disables the channel 5 status and control register and reverts TACH5 pin to general-purpose I/O.

Reset clears the MSxB bit.

- 1 = Buffered output compare/PWM operation enabled
- 0 = Buffered output compare/PWM operation disabled

MSxA — Mode Select Bit A

When ELSxB:A \neq 00, this read/write bit selects either input capture operation or unbuffered output compare/PWM operation. See [Table 22-2](#).

- 1 = Unbuffered output compare/PWM operation
- 0 = Input capture operation

When ELSxB:A = 00, this read/write bit selects the initial output level of the TACHx pin once PWM, output compare mode or input capture mode is enabled. See [Table 22-2](#). Reset clears the MSxA bit.

- 1 = Initial output level low
- 0 = Initial output level high

NOTE: *Before changing a channel function by writing to the MSxB or MSxA bit, set the TSTOP and TRST bits in the TIMA status and control register (TASC).*

ELSxB and ELSxA — Edge/Level Select Bits

When channel x is an input capture channel, these read/write bits control the active edge-sensing logic on channel x.

When channel x is an output compare channel, ELSxB and ELSxA control the channel x output behavior when an output compare occurs.

When ELSxB and ELSxA are both clear, channel x is not connected to port E or port F and pin PTE_x/TACH_x or pin PTF_x/TACH_x is available as a general-purpose I/O pin. However, channel x is at a state determined by these bits and becomes transparent to the respective pin when PWM, input capture mode or output compare operation mode is enabled. [Table 22-2](#) shows how ELSxB and ELSxA work. Reset clears the ELSxB and ELSxA bits.

Table 22-2. Mode, Edge, and Level Selection

MSxB:MSxA	ELSxB:ELSxA	Mode	Configuration
X0	00	Output Preset	Pin under Port Control; Initialize Timer Output Level High
X1	00		Pin under Port Control; Initialize Timer Output Level Low
00	01	Input Capture	Capture on Rising Edge Only
00	10		Capture on Falling Edge Only
00	11		Capture on Rising or Falling Edge
01	01	Output Compare or PWM	Toggle Output on Compare
01	10		Clear Output on Compare
01	11		Set Output on Compare
1X	01	Buffered Output Compare or Buffered PWM	Toggle Output on Compare
1X	10		Clear Output on Compare
1X	11		Set Output on Compare

NOTE: Before enabling a TIMA channel register for input capture operation, make sure that the PTE_x/TACH_x pin or PTF_x/TACH_x pin is stable for at least two bus clocks.

TOV_x — Toggle-On-Overflow Bit

When channel x is an output compare channel, this read/write bit controls the behavior of the channel x output when the TIMA counter overflows. When channel x is an input capture channel, TOV_x has no effect. Reset clears the TOV_x bit.

1 = Channel x pin toggles on TIMA counter overflow.

0 = Channel x pin does not toggle on TIMA counter overflow.

NOTE: When TOV_x is set, a TIMA counter overflow takes precedence over a channel x output compare if both occur at the same time.

CHxMAX — Channel x Maximum Duty Cycle Bit

When the TOVx bit is at logic 1, setting the CHxMAX bit forces the duty cycle of buffered and unbuffered PWM signals to 100%. As **Figure 22-8** shows, the CHxMAX bit takes effect in the cycle after it is set or cleared. The output stays at the 100% duty cycle level until the cycle after CHxMAX is cleared.

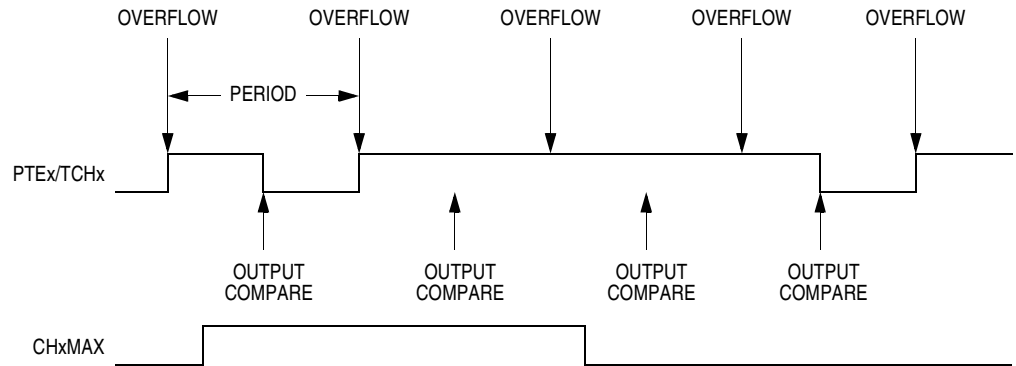

Figure 22-8. CHxMAX Latency

22.9.5 TIMA Channel Registers

These read/write registers contain the captured TIMA counter value of the input capture function or the output compare value of the output compare function. The state of the TIMA channel registers after reset is unknown.

In input capture mode ($MSxB-MSxA = 0:0$) reading the high byte of the TIMA channel x registers (TACHxH) inhibits input captures until the low byte (TACHxL) is read.

In output compare mode ($MSxB-MSxA \neq 0:0$) writing to the high byte of the TIMA channel x registers (TACHxH) inhibits output compares and the CHxF bit until the low byte (TACHxL) is written.

Timer Interface Module A (TIMA)

Register Name and Address TACH0H — \$0027

	Bit 7	6	5	4	3	2	1	Bit 0
Read:	Bit 15	Bit 14	Bit 13	Bit 12	Bit 11	Bit 10	Bit 9	Bit 8
Write:	Bit 15	Bit 14	Bit 13	Bit 12	Bit 11	Bit 10	Bit 9	Bit 8
Reset:	Indeterminate after Reset							

Register Name and Address TACH0L — \$0028

	Bit 7	6	5	4	3	2	1	Bit 0
Read:	Bit 7	Bit 6	Bit 5	Bit 4	Bit 3	Bit 2	Bit 1	Bit 0
Write:	Bit 7	Bit 6	Bit 5	Bit 4	Bit 3	Bit 2	Bit 1	Bit 0
Reset:	Indeterminate after Reset							

Register Name and Address TACH1H — \$002A

	Bit 7	6	5	4	3	2	1	Bit 0
Read:	Bit 15	Bit 14	Bit 13	Bit 12	Bit 11	Bit 10	Bit 9	Bit 8
Write:	Bit 15	Bit 14	Bit 13	Bit 12	Bit 11	Bit 10	Bit 9	Bit 8
Reset:	Indeterminate after Reset							

Register Name and Address TACH1L — \$002B

	Bit 7	6	5	4	3	2	1	Bit 0
Read:	Bit 7	Bit 6	Bit 5	Bit 4	Bit 3	Bit 2	Bit 1	Bit 0
Write:	Bit 7	Bit 6	Bit 5	Bit 4	Bit 3	Bit 2	Bit 1	Bit 0
Reset:	Indeterminate after Reset							

Register Name and Address TACH2H — \$002D

	Bit 7	6	5	4	3	2	1	Bit 0
Read:	Bit 15	Bit 14	Bit 13	Bit 12	Bit 11	Bit 10	Bit 9	Bit 8
Write:	Bit 15	Bit 14	Bit 13	Bit 12	Bit 11	Bit 10	Bit 9	Bit 8
Reset:	Indeterminate after Reset							

Figure 22-9. TIMA Channel Registers (TACH0H/L–TACH5H/L) (Sheet 1 of 3)

Register Name and Address TACH2L — \$002E

	Bit 7	6	5	4	3	2	1	Bit 0
Read:	Bit 7	Bit 6	Bit 5	Bit 4	Bit 3	Bit 2	Bit 1	Bit 0
Write:	Bit 7	Bit 6	Bit 5	Bit 4	Bit 3	Bit 2	Bit 1	Bit 0
Reset:	Indeterminate after Reset							

Register Name and Address TACH3H — \$0030

	Bit 7	6	5	4	3	2	1	Bit 0
Read:	Bit 15	Bit 14	Bit 13	Bit 12	Bit 11	Bit 10	Bit 9	Bit 8
Write:	Bit 15	Bit 14	Bit 13	Bit 12	Bit 11	Bit 10	Bit 9	Bit 8
Reset:	Indeterminate after Reset							

Register Name and Address TACH3L — \$0031

	Bit 7	6	5	4	3	2	1	Bit 0
Read:	Bit 7	Bit 6	Bit 5	Bit 4	Bit 3	Bit 2	Bit 1	Bit 0
Write:	Bit 7	Bit 6	Bit 5	Bit 4	Bit 3	Bit 2	Bit 1	Bit 0
Reset:	Indeterminate after Reset							

Register Name and Address TACH4H — \$0033

	Bit 7	6	5	4	3	2	1	Bit 0
Read:	Bit 15	Bit 14	Bit 13	Bit 12	Bit 11	Bit 10	Bit 9	Bit 8
Write:	Bit 15	Bit 14	Bit 13	Bit 12	Bit 11	Bit 10	Bit 9	Bit 8
Reset:	Indeterminate after Reset							

Register Name and Address TACH4L — \$0034

	Bit 7	6	5	4	3	2	1	Bit 0
Read:	Bit 7	Bit 6	Bit 5	Bit 4	Bit 3	Bit 2	Bit 1	Bit 0
Write:	Bit 7	Bit 6	Bit 5	Bit 4	Bit 3	Bit 2	Bit 1	Bit 0
Reset:	Indeterminate after Reset							

Figure 22-9. TIMA Channel Registers (TACH0H/L–TACH5H/L) (Sheet 2 of 3)

Timer Interface Module A (TIMA)

Register Name and Address TACH5H — \$0036

	Bit 7	6	5	4	3	2	1	Bit 0
Read:								
Write:	Bit 15	Bit 14	Bit 13	Bit 12	Bit 11	Bit 10	Bit 9	Bit 8
Reset:	Indeterminate after Reset							

Register Name and Address TACH5L — \$0037

	Bit 7	6	5	4	3	2	1	Bit 0
Read:								
Write:	Bit 7	Bit 6	Bit 5	Bit 4	Bit 3	Bit 2	Bit 1	Bit 0
Reset:	Indeterminate after Reset							

Figure 22-9. TIMA Channel Registers (TACH0H/L–TACH5H/L) (Sheet 3 of 3)

Section 23. Analog-to-Digital Converter (ADC)

23.1 Contents

23.2	Introduction	362
23.3	Features	362
23.4	Functional Description	362
23.4.1	ADC Port I/O Pins	363
23.4.2	Voltage Conversion	364
23.4.3	Conversion Time	364
23.4.4	Continuous Conversion	365
23.4.5	Accuracy and Precision	365
23.5	Interrupts	365
23.6	Low-Power Modes	365
23.6.1	Wait Mode	365
23.6.2	Stop Mode	366
23.7	I/O Signals	366
23.7.1	ADC Analog Power Pin (VDDAREF)/ADC Voltage Reference Pin (V_{REFH})	366
23.7.2	ADC Analog Ground Pin (VSSA)/ADC Voltage Reference Low Pin (V_{REFL})	366
23.7.3	ADC Voltage In (ADCVIN)	366
23.8	I/O Registers	367
23.8.1	ADC Status and Control Register	367
23.8.2	ADC Data Register	370
23.8.3	ADC Input Clock Register	370

23.2 Introduction

This section describes the analog-to-digital converter (ADC-15). The ADC is an 8-bit analog-to-digital converter.

For further information regarding analog-to-digital converters on Motorola microcontrollers, please consult the HC08 ADC Reference Manual, ADCRM/AD.

23.3 Features

Features of the ADC module include:

- 15 Channels with Multiplexed Input
- Linear Successive Approximation
- 8-Bit Resolution
- Single or Continuous Conversion
- Conversion Complete Flag or Conversion Complete Interrupt
- Selectable ADC Clock

23.4 Functional Description

Fifteen ADC channels are available for sampling external sources at pins PTD6/ATD14/TACLK-PTD0/ATD8 and PTB7/ATD7-PTB0/ATD0. An analog multiplexer allows the single ADC converter to select one of 15 ADC channels as ADC voltage in (ADCVIN). ADCVIN is converted by the successive approximation register-based counters. When the conversion is completed, ADC places the result in the ADC data register and sets a flag or generates an interrupt. See [Figure 23-1](#).

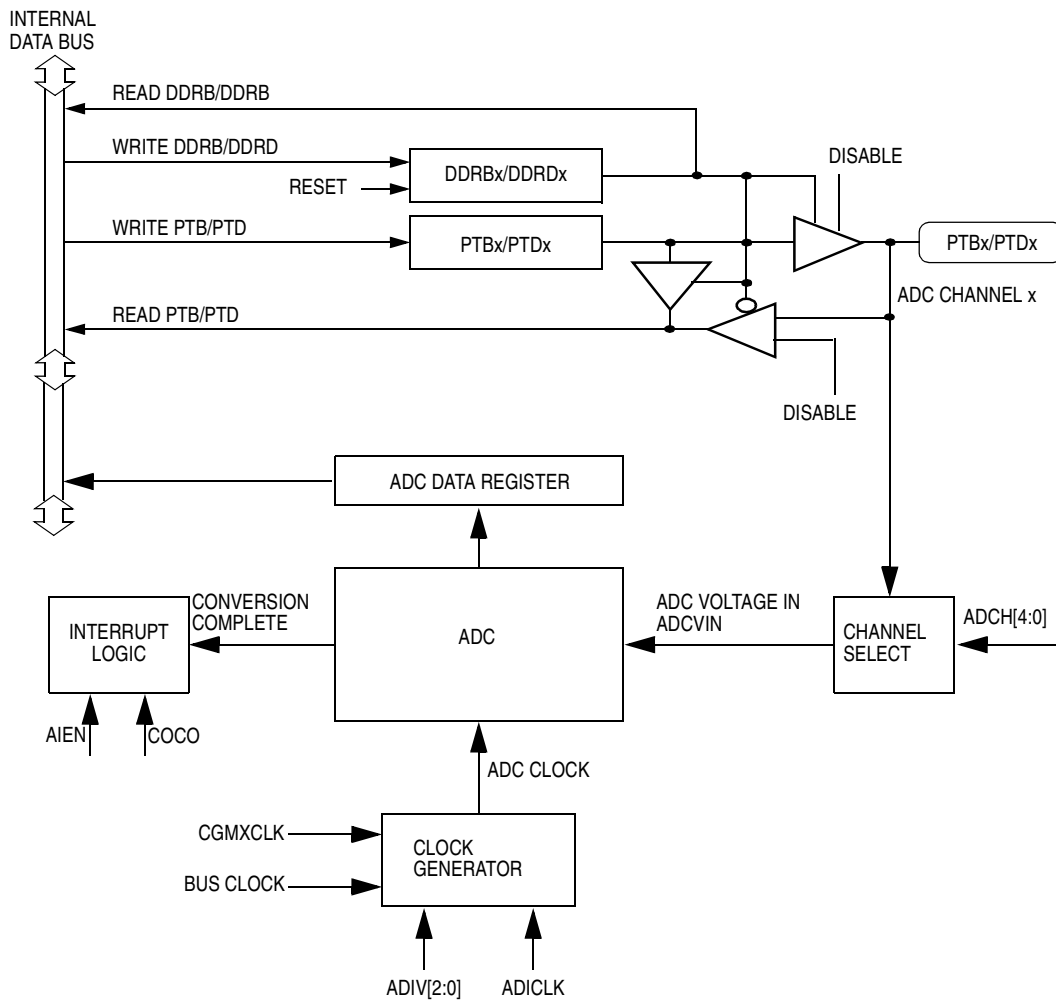

Figure 23-1. ADC Block Diagram

23.4.1 ADC Port I/O Pins

PTD6/ATD14/TACLK–PTD0/ATD8 and PTB7/ATD7–PTB0/ATD0 are general-purpose I/O pins that share with the ADC channels.

The channel select bits define which ADC channel/port pin will be used as the input signal. The ADC overrides the port I/O logic by forcing that pin as input to the ADC. The remaining ADC channels/port pins are controlled by the port I/O logic and can be used as general-purpose I/O. Writes to the port register or DDR will not have any affect on the port pin that is selected by the ADC. Read of a port pin which is in use by the

ADC will return a logic 0 if the corresponding DDR bit is at logic 0. If the DDR bit is at logic 1, the value in the port data latch is read.

NOTE: Do not use ADC channels ATD14 or ATD12 when using the PTD6/ATD14/TACLK or PTD4/ATD12/TBCLK pins as the clock inputs for the 16-bit Timers.

23.4.2 Voltage Conversion

When the input voltage to the ADC equals V_{REFH} (see [ADC Characteristics](#) on page 424), the ADC converts the signal to \$FF (full scale). If the input voltage equals V_{SSA} , the ADC converts it to \$00. Input voltages between V_{REFH} and V_{SSA} are a straight-line linear conversion. Conversion accuracy of all other input voltages is not guaranteed. Avoid current injection on unused ADC inputs to prevent potential conversion error.

NOTE: Input voltage should not exceed the analog supply voltages.

23.4.3 Conversion Time

Conversion starts after a write to the ADSCR (ADC status control register, \$0038), and requires between 16 and 17 ADC clock cycles to complete. Conversion time in terms of the number of bus cycles is a function of ADICLK select, CGMXCLK frequency, bus frequency, and ADIV prescaler bits. For example, with a CGMXCLK frequency of 4 MHz, bus frequency of 8 MHz, and fixed ADC clock frequency of 1 MHz, one conversion will take between 16 and 17 μ s and there will be between 128 bus cycles between each conversion. Sample rate is approximately 60 kHz.

Refer to [ADC Characteristics](#) on page 424.

$$\text{Conversion Time} = \frac{16 \text{ to } 17 \text{ ADC Clock Cycles}}{\text{ADC Clock Frequency}}$$

$$\text{Number of Bus Cycles} = \text{Conversion Time} \times \text{Bus Frequency}$$

23.4.4 Continuous Conversion

In the continuous conversion mode, the ADC data register will be filled with new data after each conversion. Data from the previous conversion will be overwritten whether that data has been read or not. Conversions will continue until the ADCO bit (ADC status control register, \$0038) is cleared. The COCO bit is set after the first conversion and will stay set for the next several conversions until the next write of the ADC status and control register or the next read of the ADC data register.

23.4.5 Accuracy and Precision

The conversion process is monotonic and has no missing codes. See [ADC Characteristics](#) on page 424 for accuracy information.

23.5 Interrupts

When the AIEN bit is set, the ADC module is capable of generating a CPU interrupt after each ADC conversion. A CPU interrupt is generated if the COCO bit (ADC status control register, \$0038) is at logic 0. If the COCO bit is set, an interrupt is generated. The COCO bit is not used as a conversion complete flag when interrupts are enabled.

23.6 Low-Power Modes

The following subsections describe the low-power modes.

23.6.1 Wait Mode

The ADC continues normal operation during wait mode. Any enabled CPU interrupt request from the ADC can bring the MCU out of wait mode. If the ADC is not required to bring the MCU out of wait mode, power down the ADC by setting the ADCH[4:0] bits in the ADC status and control register before executing the WAIT instruction.

23.6.2 Stop Mode

The ADC module is inactive after the execution of a STOP instruction. Any pending conversion is aborted. ADC conversions resume when the MCU exits stop mode. Allow one conversion cycle to stabilize the analog circuitry before attempting a new ADC conversion after exiting stop mode.

23.7 I/O Signals

The ADC module has 15 channels that are shared with I/O ports B and D. Refer to [ADC Characteristics](#) on page 424 for voltages referenced below.

23.7.1 ADC Analog Power Pin (V_{DDAREF})/ADC Voltage Reference Pin (V_{REFH})

The ADC analog portion uses V_{DDAREF} as its power pin. Connect the V_{DDA}/V_{DDAREF} pin to the same voltage potential as V_{DD} . External filtering may be necessary to ensure clean V_{DDAREF} for good results.

V_{REFH} is the high reference voltage for all analog-to-digital conversions.

NOTE: *Route V_{DDAREF} carefully for maximum noise immunity and place bypass capacitors as close as possible to the package. V_{DDAREF} must be present for operation of the ADC.*

23.7.2 ADC Analog Ground Pin (V_{SSA})/ADC Voltage Reference Low Pin (V_{REFL})

The ADC analog portion uses V_{SSA} as its ground pin. Connect the V_{SSA} pin to the same voltage potential as V_{SS} .

V_{REFL} is the lower reference supply for the ADC.

23.7.3 ADC Voltage In (ADCVIN)

ADCVIN is the input voltage signal from one of the 15 ADC channels to the ADC module.

23.8 I/O Registers

These I/O registers control and monitor ADC operation:

- ADC status and control register (ADSCR)
- ADC data register (ADR)
- ADC clock register (ADICLK)

23.8.1 ADC Status and Control Register

The following paragraphs describe the function of the ADC status and control register.

Address: \$0038

	Bit 7	6	5	4	3	2	1	Bit 0
Read:	COCO	AIEN	ADCO	CH4	CH3	CH2	CH1	CH0
Write:	R							
Reset:	0	0	0	1	1	1	1	1

R

 = Reserved

Figure 23-2. ADC Status and Control Register (ADSCR)

COCO — Conversions Complete Bit

When the AIEN bit is a logic 0, the COCO is a read-only bit which is set each time a conversion is completed. This bit is cleared whenever the ADC status and control register is written or whenever the ADC data register is read.

If the AIEN bit is a logic 1, the COCO is a read/write bit which selects the CPU to service the ADC interrupt request. Reset clears this bit.

1 = conversion completed (AIEN = 0)

0 = conversion not completed (AIEN = 0)

or

CPU interrupt enabled (AIEN = 1)

AIEN — ADC Interrupt Enable Bit

When this bit is set, an interrupt is generated at the end of an ADC conversion. The interrupt signal is cleared when the data register is read or the status/control register is written. Reset clears the AIEN bit.

1 = ADC interrupt enabled

0 = ADC interrupt disabled

ADCO — ADC Continuous Conversion Bit

When set, the ADC will convert samples continuously and update the ADR register at the end of each conversion. Only one conversion is allowed when this bit is cleared. Reset clears the ADCO bit.

1 = Continuous ADC conversion

0 = One ADC conversion

ADCH[4:0] — ADC Channel Select Bits

ADCH4, ADCH3, ADCH2, ADCH1, and ADCH0 form a 5-bit field which is used to select one of 15 ADC channels. Channel selection is detailed in the following table. Care should be taken when using a port pin as both an analog and a digital input simultaneously to prevent switching noise from corrupting the analog signal. See [Table 23-1](#).

The ADC subsystem is turned off when the channel select bits are all set to one. This feature allows for reduced power consumption for the MCU when the ADC is not used. Reset sets these bits.

NOTE: *Recovery from the disabled state requires one conversion cycle to stabilize.*

Table 23-1. Mux Channel Select

ADCH4	ADCH3	ADCH2	ADCH1	ADCH0	Input Select
0	0	0	0	0	PTB0/ATD0
0	0	0	0	1	PTB1/ATD1
0	0	0	1	0	PTB2/ATD2
0	0	0	1	1	PTB3/ATD3
0	0	1	0	0	PTB4/ATD4
0	0	1	0	1	PTB5/ATD5
0	0	1	1	0	PTB6/ATD6

Table 23-1. Mux Channel Select

ADCH4	ADCH3	ADCH2	ADCH1	ADCH0	Input Select
0	0	1	1	1	PTB7/ATD7
0	1	0	0	0	PTD0/ATD8/ATD8
0	1	0	0	1	PTD1/ATD9/ATD9
0	1	0	1	0	PTD2/ATD10/ATD10
0	1	0	1	1	PTD3/ATD11/ATD11
0	1	1	0	0	PTD4/ATD12/TBCLK/ ATD12
0	1	1	0	1	PTD5/ATD13/ATD13
0	1	1	1	0	PTD6/ATD14/TACLK/ ATD14
Range 01111 (\$0F) to 11010 (\$1A)					Unused (see Note 1)
					Unused (see Note 1)
1	1	0	1	1	Reserved
1	1	1	0	0	Unused (see Note 1)
1	1	1	0	1	V_{REFH} (see Note 2)
1	1	1	1	0	V_{SSA}/V_{REFL} (see Note 2)
1	1	1	1	1	[ADC power off]

NOTES:

1. If any unused channels are selected, the resulting ADC conversion will be unknown.
2. The voltage levels supplied from internal reference nodes as specified in the table are used to verify the operation of the ADC converter both in production test and for user applications.

Analog-to-Digital Converter (ADC)

23.8.2 ADC Data Register

One 8-bit result register is provided. This register is updated each time an ADC conversion completes.

Address: \$0039

	Bit 7	6	5	4	3	2	1	Bit 0
Read:	AD7	AD6	AD5	AD4	AD3	AD2	AD1	AD0
Write:	R	R	R	R	R	R	R	R
Reset:	Indeterminate after Reset							

R

 = Reserved

Figure 23-3. ADC Data Register (ADR)

23.8.3 ADC Input Clock Register

This register selects the clock frequency for the ADC.

Address: \$003A

	Bit 7	6	5	4	3	2	1	Bit 0
Read:	ADIV2	ADIV1	ADIV0	ADICLK	0	0	0	0
Write:	R	R	R	R	R	R	R	R
Reset:	0	0	0	0	0	0	0	0

R

 = Reserved

Figure 23-4. ADC Input Clock Register (ADICLK)

ADIV2–ADIV0 — ADC Clock Prescaler Bits

ADIV2, ADIV1, and ADIV0 form a 3-bit field which selects the divide ratio used by the ADC to generate the internal ADC clock. [Table 23-2](#) shows the available clock configurations. The ADC clock should be set to approximately 1 MHz.

Table 23-2. ADC Clock Divide Ratio

ADIV2	ADIV1	ADIV0	ADC Clock Rate
0	0	0	ADC Input Clock / 1
0	0	1	ADC Input Clock / 2
0	1	0	ADC Input Clock / 4
0	1	1	ADC Input Clock / 8
1	X	X	ADC Input Clock / 16

X = don't care

ADICLK — ADC Input Clock Register Bit

ADICLK selects either bus clock or CGMXCLK as the input clock source to generate the internal ADC clock. Reset selects CGMXCLK as the ADC clock source.

If the external clock (CGMXCLK) is equal to or greater than 1 MHz, CGMXCLK can be used as the clock source for the ADC. If CGMXCLK is less than 1 MHz, use the PLL-generated bus clock as the clock source. As long as the internal ADC clock is at approximately 1 MHz, correct operation can be guaranteed. See [ADC Characteristics](#) on page 424.

1 = Internal bus clock

0 = External clock (CGMXCLK)

$$1 \text{ MHz} = \frac{f_{\text{XCLK or Bus Frequency}}}{\text{ADIV}[2:0]}$$

NOTE: *During the conversion process, changing the ADC clock will result in an incorrect conversion.*

Section 24. Byte Data Link Controller (BDLC)

24.1 Contents

24.2	Introduction	374
24.3	Features	374
24.4	Functional Description	375
24.4.1	BDLC Operating Modes	377
24.4.1.1	Power Off Mode	377
24.4.1.2	Reset Mode	378
24.4.1.3	Run Mode	378
24.4.1.4	BDLC Wait Mode	378
24.4.1.5	BDLC Stop Mode	379
24.4.1.6	Digital Loopback Mode	379
24.4.1.7	Analog Loopback Mode	379
24.5	BDLC MUX Interface	380
24.5.1	Rx Digital Filter	380
24.5.1.1	Operation	381
24.5.1.2	Performance	382
24.5.2	J1850 Frame Format	383
24.5.3	J1850 VPW Symbols	386
24.5.4	J1850 VPW Valid/Invalid Bits and Symbols	390
24.5.5	Message Arbitration	394
24.6	BDLC Protocol Handler	396
24.6.1	Protocol Architecture	397
24.6.2	Rx and Tx Shift Registers	397
24.6.3	Rx and Tx Shadow Registers	398
24.6.4	Digital Loopback Multiplexer	398
24.6.5	State Machine	398
24.6.5.1	4X Mode	398
24.6.5.2	Receiving a Message in Block Mode	399
24.6.5.3	Transmitting a Message in Block Mode	399
24.6.5.4	J1850 Bus Errors	399

24.6.5.5	Summary	401
24.7	BDLC CPU Interface	402
24.7.1	BDLC Analog and Roundtrip Delay Register	403
24.7.2	BDLC Control Register 1	404
24.7.3	BDLC Control Register 2	407
24.7.4	BDLC State Vector Register	414
24.7.5	BDLC Data Register	416
24.8	Low-Power Modes	417
24.8.1	Wait Mode	417
24.8.2	Stop Mode	418

24.2 Introduction

The byte data link controller (BDLC) provides access to an external serial communication multiplex bus, operating according to the Society of Automotive Engineers (SAE) J1850 protocol.

The BDLC-D is only available on the MC68HC908AS60A.

24.3 Features

Features of the BDLC module include:

- SAE J1850 class B data communications network interface compatible and ISO compatible for low speed (≤ 125 kbps) serial data communications in automotive applications
- 10.4 kbps variable pulse width (VPW) bit format
- Digital noise filter
- Collision detection
- Hardware cyclical redundancy check (CRC) generation and checking
- Two power-saving modes with automatic wakeup on network activity
- Polling and CPU interrupts available

- Block mode receive and transmit supported
- Supports 4X receive mode, 41.6 kbps
- Digital loopback mode
- Analog loopback mode
- In-frame response (IFR) types 0, 1, 2, and 3 supported

24.4 Functional Description

Figure 24-1 shows the organization of the BDLC module. The CPU interface contains the software addressable registers and provides the link between the CPU and the buffers. The buffers provide storage for data received and data to be transmitted onto the J1850 bus. The protocol handler is responsible for the encoding and decoding of data bits and special message symbols during transmission and reception. The MUX interface provides the link between the BDLC digital section and the analog physical interface. The wave shaping, driving, and digitizing of data is performed by the physical interface.

Use of the BDLC module in message networking fully implements the *SAE Standard J1850 Class B Data Communication Network Interface* specification.

NOTE: *It is recommended that the reader be familiar with the SAE J1850 document and ISO Serial Communication document prior to proceeding with this section of the MC68HC908AS32A specification.*

Byte Data Link Controller (BDLC)

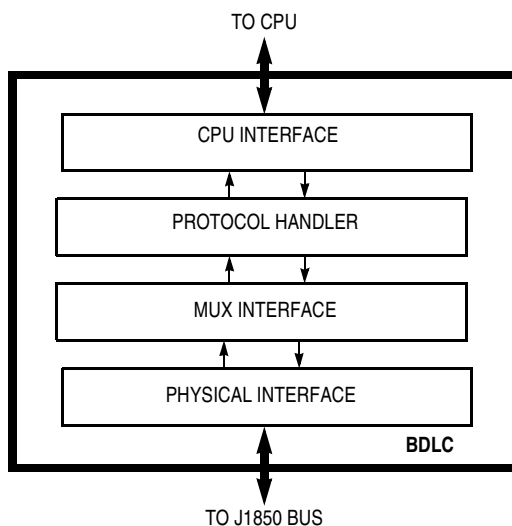

Figure 24-1. BDLC Block Diagram

Table 24-1. BDLC I/O Register Summary

Addr.	Name		Bit 7	6	5	4	3	2	1	Bit 0
\$003B	BDLC Analog and Roundtrip Delay Register (BARD)	Read:			0	0	BO3	BO2	BO1	BO0
		Write:	ATE	RXPOL	R	R				
\$003C	BDLC Control Register 1 (BCR1)	Read:					0	0	IE	WCM
		Write:	IMSG	CLKS	R1	R0	R	R		
\$003D	BDLC Control Register 2 (BCR2)	Read:								
		Write:	ALOOP	DLOOP	RX4XE	NBFS	TEOD	TSIFR	TMIFR1	TMIFR0
\$003E	BDLC State Vector Register (BSVR)	Read:	0	0	I3	I2	I1	I0	0	0
		Write:	R	R	R	R	R	R	R	R
\$003F	BDLC Data Register (BDR)	Read:								
		Write:	BD7	BD6	BD5	BD4	BD3	BD2	BD1	BD0

R = Reserved

24.4.1 BDLC Operating Modes

The BDLC has five main modes of operation which interact with the power supplies, pins, and the remainder of the MCU as shown in [Figure 24-2](#).

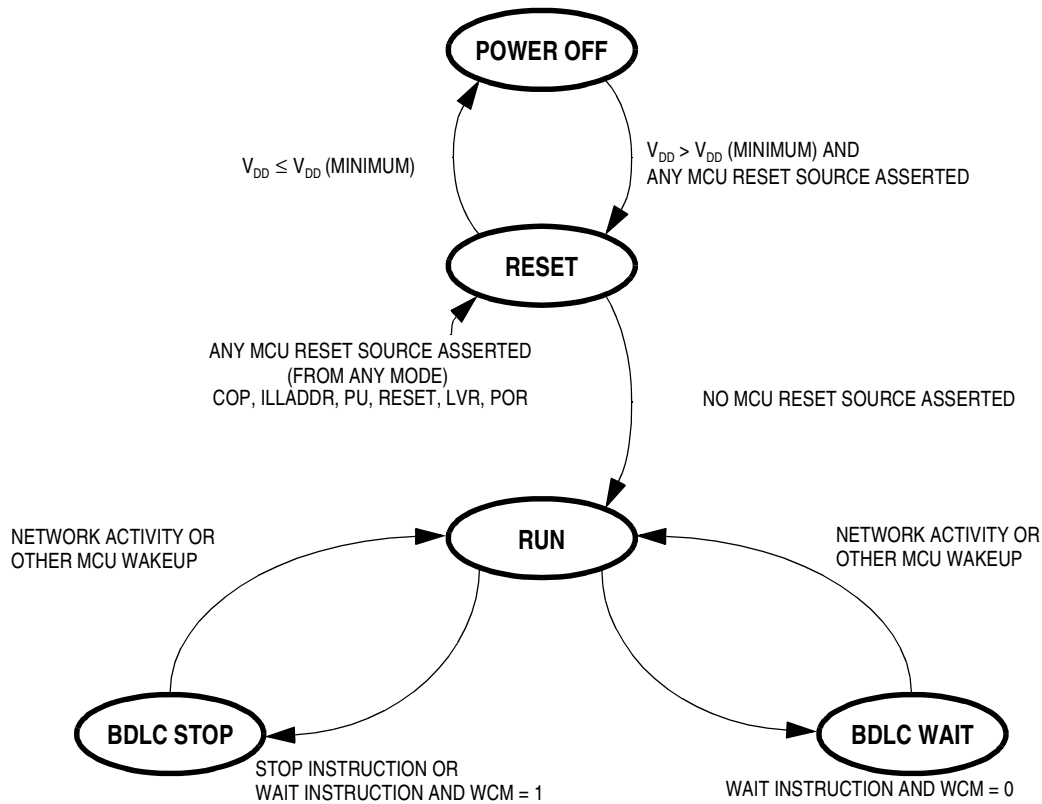

Figure 24-2. BDLC Operating Modes State Diagram

24.4.1.1 Power Off Mode

This mode is entered from reset mode whenever the BDLC supply voltage, V_{DD} , drops below its minimum specified value for the BDLC to guarantee operation. The BDLC will be placed in reset mode by low-voltage reset (LVR) before being powered down. In this mode, the pin input and output specifications are not guaranteed.

24.4.1.2 Reset Mode

This mode is entered from the power off mode whenever the BDLC supply voltage, V_{DD} , rises above its minimum specified value ($V_{DD} - 10\%$) and some MCU reset source is asserted. The internal MCU reset must be asserted while powering up the BDLC or an unknown state will be entered and correct operation cannot be guaranteed. Reset mode is also entered from any other mode as soon as one of the MCU's possible reset sources (such as LVR, POR, COP watchdog, and reset pin, etc.) is asserted.

In reset mode, the internal BDLC voltage references are operative; V_{DD} is supplied to the internal circuits which are held in their reset state; and the internal BDLC system clock is running. Registers will assume their reset condition. Outputs are held in their programmed reset state. Therefore, inputs and network activity are ignored.

24.4.1.3 Run Mode

This mode is entered from the reset mode after all MCU reset sources are no longer asserted. Run mode is entered from the BDLC wait mode whenever activity is sensed on the J1850 bus.

Run mode is entered from the BDLC stop mode whenever network activity is sensed, although messages will not be received properly until the clocks have stabilized and the CPU is in run mode also.

In this mode, normal network operation takes place. The user should ensure that all BDLC transmissions have ceased before exiting this mode.

24.4.1.4 BDLC Wait Mode

This power-conserving mode is entered automatically from run mode whenever the CPU executes a WAIT instruction and if the WCM bit in the BCR1 register is cleared previously.

In this mode, the BDLC internal clocks continue to run. The first passive-to-active transition of the bus generates a CPU interrupt request from the BDLC which wakes up the BDLC and the CPU. In addition, if the BDLC

receives a valid EOF symbol while operating in wait mode, then the BDLC also will generate a CPU interrupt request which wakes up the BDLC and the CPU. See **Wait Mode**.

24.4.1.5 BDLC Stop Mode

This power-conserving mode is entered automatically from run mode whenever the CPU executes a STOP instruction or if the CPU executes a WAIT instruction and the WCM bit in the BCR1 register is set previously.

In this mode, the BDLC internal clocks are stopped but the physical interface circuitry is placed in a low-power mode and awaits network activity. If network activity is sensed, then a CPU interrupt request will be generated, restarting the BDLC internal clocks. See **Stop Mode**.

24.4.1.6 Digital Loopback Mode

When a bus fault has been detected, the digital loopback mode is used to determine if the fault condition is caused by failure in the node's internal circuits or elsewhere in the network, including the node's analog physical interface. In this mode, the transmit digital output pin (BDTxD) and the receive digital input pin (BDRxD) of the digital interface are disconnected from the analog physical interface and tied together to allow the digital portion of the BDLC to transmit and receive its own messages without driving the J1850 bus.

24.4.1.7 Analog Loopback Mode

Analog loopback is used to determine if a bus fault has been caused by a failure in the node's off-chip analog transceiver or elsewhere in the network. The BCLD analog loopback mode does not modify the digital transmit or receive functions of the BDLC. It does, however, ensure that once analog loopback mode is exited, the BDLC will wait for an idle bus condition before participation in network communication resumes. If the off-chip analog transceiver has a loopback mode, it usually causes the input to the output drive stage to be looped back into the receiver, allowing the node to receive messages it has transmitted without driving the J1850 bus. In this mode, the output to the J1850 bus is typically high

impedance. This allows the communication path through the analog transceiver to be tested without interfering with network activity. Using the BDLC analog loopback mode in conjunction with the analog transceiver's loopback mode ensures that, once the off-chip analog transceiver has exited loopback mode, the BCLD will not begin communicating before a known condition exists on the J1850 bus.

24.5 BDLC MUX Interface

The MUX interface is responsible for bit encoding/decoding and digital noise filtering between the protocol handler and the physical interface.

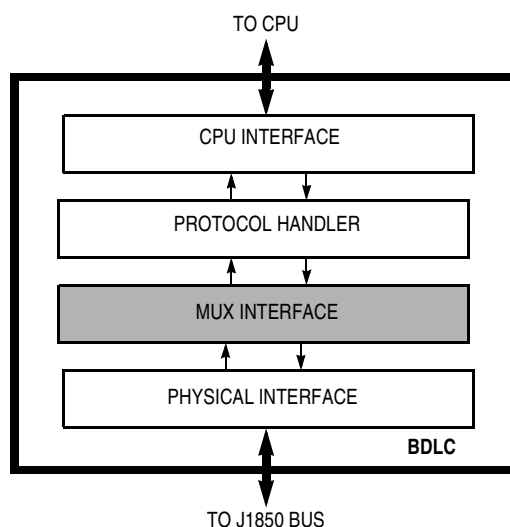

Figure 24-3. BDLC Block Diagram

24.5.1 Rx Digital Filter

The receiver section of the BDLC includes a digital low pass filter to remove narrow noise pulses from the incoming message. An outline of the digital filter is shown in [Figure 24-4](#).

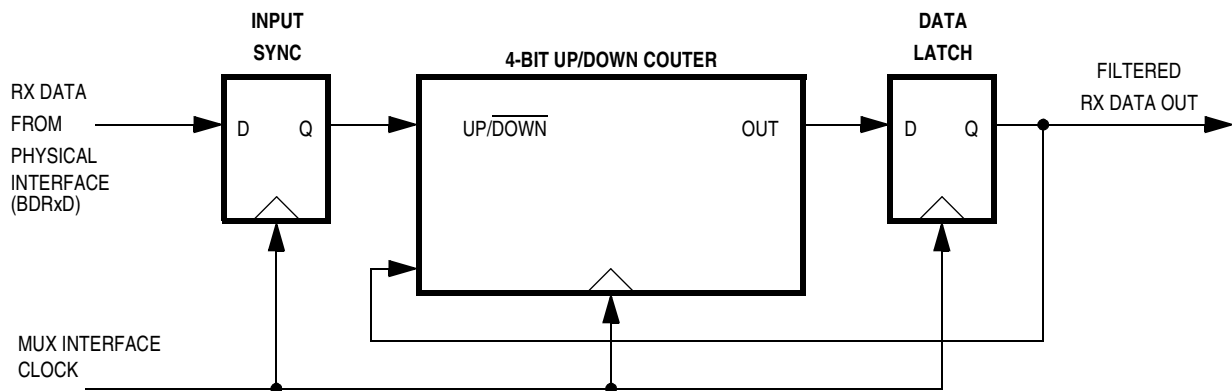

Figure 24-4. BDLC Rx Digital Filter Block Diagram

24.5.1.1 Operation

The clock for the digital filter is provided by the MUX interface clock (see f_{BDLC} parameter in [Table 24-4](#)). At each positive edge of the clock signal, the current state of the receiver physical interface (BDRxD) signal is sampled. The BDRxD signal state is used to determine whether the counter should increment or decrement at the next negative edge of the clock signal.

The counter will increment if the input data sample is high but decrement if the input sample is low. Therefore, the counter will thus progress either up toward 15 if, on average, the BDRxD signal remains high or progress down toward 0 if, on average, the BDRxD signal remains low.

When the counter eventually reaches the value 15, the digital filter decides that the condition of the BDRxD signal is at a stable logic level 1 and the data latch is set, causing the filtered Rx data signal to become a logic level 1. Furthermore, the counter is prevented from overflowing and can only be decremented from this state.

Alternatively, should the counter eventually reach the value 0, the digital filter decides that the condition of the BDRxD signal is at a stable logic level 0 and the data latch is reset, causing the filtered Rx data signal to become a logic level 0. Furthermore, the counter is prevented from underflowing and can only be incremented from this state.

The data latch will retain its value until the counter next reaches the opposite end point, signifying a definite transition of the signal.

24.5.1.2 Performance

The performance of the digital filter is best described in the time domain rather than the frequency domain.

If the signal on the BDRxD signal transitions, then there will be a delay before that transition appears at the filtered Rx data output signal. This delay will be between 15 and 16 clock periods, depending on where the transition occurs with respect to the sampling points. This filter delay must be taken into account when performing message arbitration.

For example, if the frequency of the MUX interface clock (f_{BDLC}) is 1.0486 MHz, then the period (t_{BDLC}) is 954 ns and the maximum filter delay in the absence of noise will be 15.259 μs .

The effect of random noise on the BDRxD signal depends on the characteristics of the noise itself. Narrow noise pulses on the BDRxD signal will be ignored completely if they are shorter than the filter delay. This provides a degree of low pass filtering.

If noise occurs during a symbol transition, the detection of that transition can be delayed by an amount equal to the length of the noise burst. This is just a reflection of the uncertainty of where the transition is truly occurring within the noise.

Noise pulses that are wider than the filter delay, but narrower than the shortest allowable symbol length, will be detected by the next stage of the BDLC's receiver as an invalid symbol.

Noise pulses that are longer than the shortest allowable symbol length will be detected normally as an invalid symbol or as invalid data when the frame's CRC is checked.

24.5.2 J1850 Frame Format

All messages transmitted on the J1850 bus are structured using the format shown in [Figure 24-5](#).

J1850 states that each message has a maximum length of 101 PWM bit times or 12 VPW bytes, excluding SOF, EOD, NB, and EOF, with each byte transmitted MSB first.

All VPW symbol lengths in the following descriptions are typical values at a 10.4 kbps bit rate.

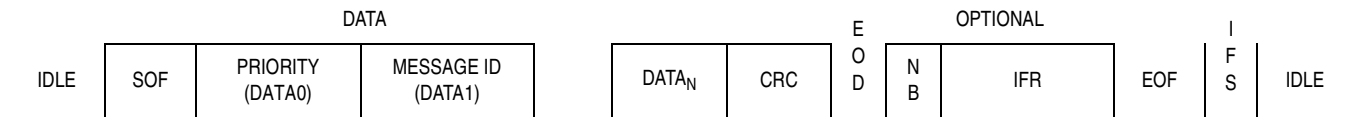

Figure 24-5. J1850 Bus Message Format (VPW)

SOF — Start-of-Frame Symbol

All messages transmitted onto the J1850 bus must begin with a long-active 200- μ s period SOF symbol. This indicates the start of a new message transmission. The SOF symbol is not used in the CRC calculation.

Data — In-Message Data Bytes

The data bytes contained in the message include the message priority/type, message ID byte (typically the physical address of the responder), and any actual data being transmitted to the receiving node. The message format used by the BDLC is similar to the 3-byte consolidated header message format outlined by the SAE J1850 document. See *SAE J1850 — Class B Data Communications Network Interface* for more information about 1- and 3-byte headers.

Messages transmitted by the BDLC onto the J1850 bus must contain at least one data byte and, therefore, can be as short as one data byte and one CRC byte. Each data byte in the message is eight bits in length and is transmitted MSB to LSB.

CRC — Cyclical Redundancy Check Byte

This byte is used by the receiver(s) of each message to determine if any errors have occurred during the transmission of the message. The BDLC calculates the CRC byte and appends it onto any messages transmitted onto the J1850 bus. It also performs CRC detection on any messages it receives from the J1850 bus.

CRC generation uses the divisor polynomial $X^8 + X^4 + X^3 + X^2 + 1$. The remainder polynomial initially is set to all ones. Each byte in the message after the start of frame (SOF) symbol is processed serially through the CRC generation circuitry. The one's complement of the remainder then becomes the 8-bit CRC byte, which is appended to the message after the data bytes in MSB-to-LSB order.

When receiving a message, the BDLC uses the same divisor polynomial. All data bytes, excluding the SOF and end of data symbols (EOD) but including the CRC byte, are used to check the CRC. If the message is error free, the remainder polynomial will equal $X^7 + X^6 + X^2 = \$C4$, regardless of the data contained in the message. If the calculated CRC does not equal $\$C4$, the BDLC will recognize this as a CRC error and set the CRC error flag in the BSVR.

EOD — End-of-Data Symbol

The EOD symbol is a long 200- μ s passive period on the J1850 bus used to signify to any recipients of a message that the transmission by the originator has completed. No flag is set upon reception of the EOD symbol.

IFR — In-Frame Response Bytes

The IFR section of the J1850 message format is optional. Users desiring further definition of in-frame response should review the *SAE J1850 — Class B Data Communications Network Interface* specification.

EOF — End-of-Frame Symbol

This symbol is a long 280- μ s passive period on the J1850 bus and is longer than an end-of-data (EOD) symbol, which signifies the end of a message. Since an EOF symbol is longer than a 200- μ s EOD

symbol, if no response is transmitted after an EOD symbol, it becomes an EOF, and the message is assumed to be completed. The EOF flag is set upon receiving the EOF symbol.

IFS — Inter-Frame Separation Symbol

The IFS symbol is a 20- μ s passive period on the J1850 bus which allows proper synchronization between nodes during continuous message transmission. The IFS symbol is transmitted by a node after the completion of the end-of-frame (EOF) period and, therefore, is seen as a 300- μ s passive period.

When the last byte of a message has been transmitted onto the J1850 bus and the EOF symbol time has expired, all nodes then must wait for the IFS symbol time to expire before transmitting a start-of-frame (SOF) symbol, marking the beginning of another message.

However, if the BDLC is waiting for the IFS period to expire before beginning a transmission and a rising edge is detected before the IFS time has expired, it will synchronize internally to that edge. If a write to the BDR register (for instance, to initiate transmission) occurred on or before $104 \cdot t_{\text{BDLC}}$ from the received rising edge, then the BDLC will transmit and arbitrate for the bus. If a CPU write to the BDR register occurred after $104 \cdot t_{\text{BDLC}}$ from the detection of the rising edge, then the BDLC will not transmit, but will wait for the next IFS period to expire before attempting to transmit the byte.

A rising edge may occur during the IFS period because of varying clock tolerances and loading of the J1850 bus, causing different nodes to observe the completion of the IFS period at different times. To allow for individual clock tolerances, receivers must synchronize to any SOF occurring during an IFS period.

NOTE: *If two messages are received with a 300 μ s ($\pm 1\mu$ s) interframe separation (IFS) as measured at the RX pin, the start-of-frame (SOF) symbol of the second message will generate an invalid symbol interrupt. This interrupt results in the second message being lost and will therefore be unavailable to the application software. Implementations of this BDLC design on silicon have not been exposed to interframe separation rates faster than 320 μ s in practical application and have therefore previously not exhibited this behavior. Ensuring that no nodes on the J1850*

network transmit messages at 300 μ s (\pm 1 μ s) IFS will avoid this missed message frame. In addition, developing application software to robustly handle lost messages will minimize application impact.

BREAK — Break

The BDLC cannot transmit a BREAK symbol.

If the BDLC is transmitting at the time a BREAK is detected, it treats the BREAK as if a transmission error had occurred and halts transmission.

If the BDLC detects a BREAK symbol while receiving a message, it treats the BREAK as a reception error and sets the invalid symbol flag in the BSVR, also ignoring the frame it was receiving. If while receiving a message in 4X mode, the BDLC detects a BREAK symbol, it treats the BREAK as a reception error, sets the invalid symbol flag, and exits 4X mode (for example, the RX4XE bit in BCR2 is cleared automatically). If bus control is required after the BREAK symbol is received and the IFS time has elapsed, the programmer must resend the transmission byte using highest priority.

NOTE: *The J1850 protocol BREAK symbol is not related to the HC08 break module. See [Break Module \(BRK\)](#) on page 157.*

IDLE — Idle Bus

An idle condition exists on the bus during any passive period after expiration of the IFS period (for instance, \geq 300 μ s). Any node sensing an idle bus condition can begin transmission immediately.

24.5.3 J1850 VPW Symbols

Huntsinger's variable pulse width modulation (VPW) is an encoding technique in which each bit is defined by the time between successive transitions and by the level of the bus between transitions (for instance, active or passive). Active and passive bits are used alternately. This encoding technique is used to reduce the number of bus transitions for a given bit rate.

Each logic 1 or logic 0 contains a single transition and can be at either the active or passive level and one of two lengths, either 64 μ s or 128 μ s

(t_{NOM} at 10.4 kbps baud rate), depending upon the encoding of the previous bit. The start-of-frame (SOF), end-of-data (EOD), end-of-frame (EOF), and inter-frame separation (IFS) symbols always will be encoded at an assigned level and length. See [Figure 24-6](#).

Each message will begin with an SOF symbol an active symbol and, therefore, each data byte (including the CRC byte) will begin with a passive bit, regardless of whether it is a logic 1 or a logic 0.

All VPW bit lengths stated in the following descriptions are typical values at a 10.4 kbps bit rate.

Logic 0

A logic 0 is defined as either:

- An active-to-passive transition followed by a passive period 64 μs in length, or
- A passive-to-active transition followed by an active period 128 μs in length

See [Figure 24-6\(a\)](#).

Byte Data Link Controller (BDLC)

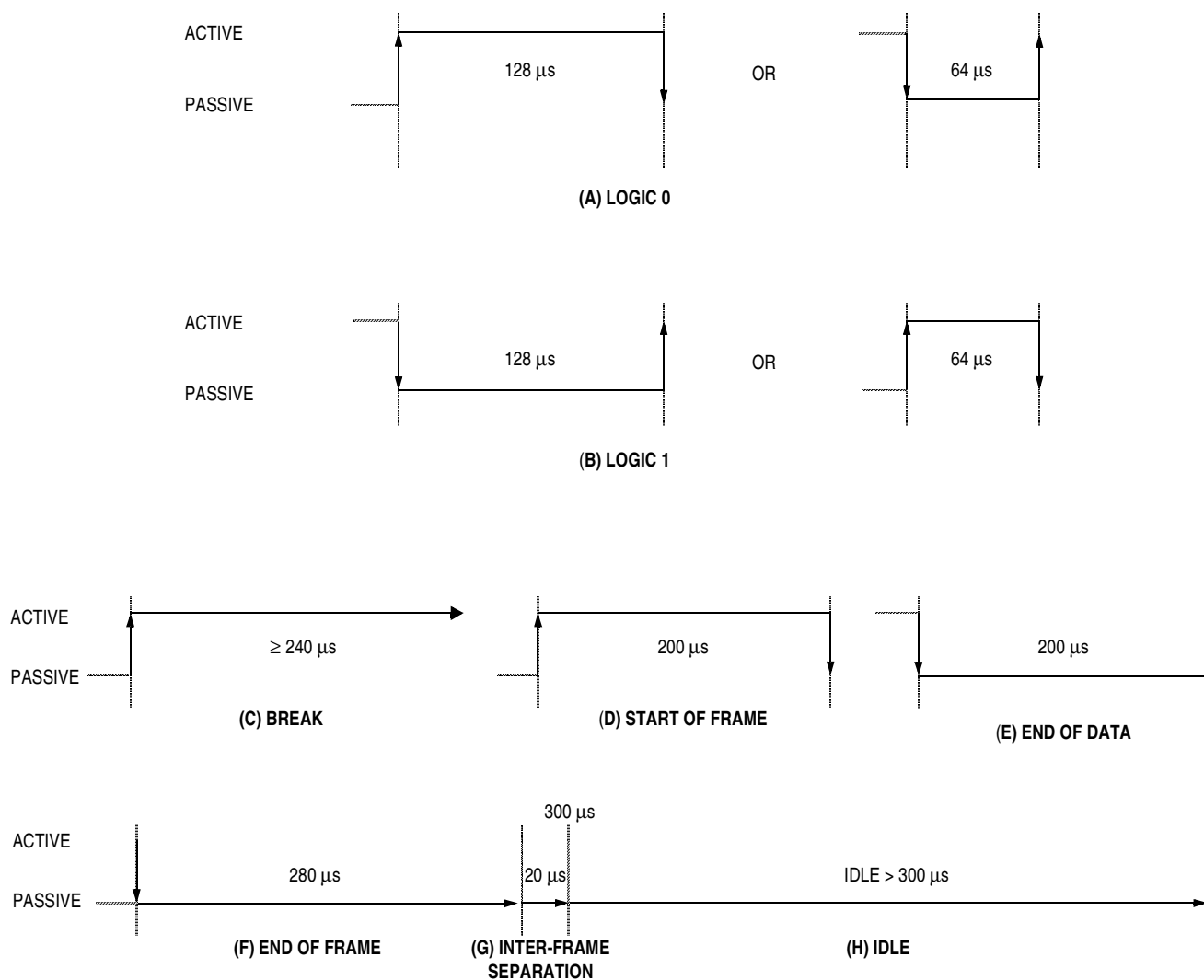

Figure 24-6. J1850 VPW Symbols with Nominal Symbol Times

Logic 1

A logic 1 is defined as either:

- An active-to-passive transition followed by a passive period 128 μs in length, or
- A passive-to-active transition followed by an active period 64 μs in length

See **Figure 24-6(b)**.

Normalization Bit (NB)

The NB symbol has the same property as a logic 1 or a logic 0. It is only used in IFR message responses.

Break Signal (BREAK)

The BREAK signal is defined as a passive-to-active transition followed by an active period of at least 240 μs (See **Figure 24-6(c)**).

Start-of-Frame Symbol (SOF)

The SOF symbol is defined as passive-to-active transition followed by an active period 200 μs in length (See **Figure 24-6(d)**). This allows the data bytes which follow the SOF symbol to begin with a passive bit, regardless of whether it is a logic 1 or a logic 0.

End-of-Data Symbol (EOD)

The EOD symbol is defined as an active-to-passive transition followed by a passive period 200 μs in length (See **Figure 24-6(e)**).

End-of-Frame Symbol (EOF)

The EOF symbol is defined as an active-to-passive transition followed by a passive period 280 μs in length (See **Figure 24-6(f)**). If no IFR byte is transmitted after an EOD symbol is transmitted, after another 80 μs the EOD becomes an EOF, indicating completion of the message.

Inter-Frame Separation Symbol (IFS)

The IFS symbol is defined as a passive period 300 μs in length. The 20- μs IFS symbol contains no transition, since when used it always appends to an EOF symbol (See **Figure 24-6(g)**).

Idle

An idle is defined as a passive period greater than 300 μs in length.

24.5.4 J1850 VPW Valid/Invalid Bits and Symbols

The timing tolerances for **receiving** data bits and symbols from the J1850 bus have been defined to allow for variations in oscillator frequencies. In many cases the maximum time allowed to define a data bit or symbol is equal to the minimum time allowed to define another data bit or symbol.

Since the minimum resolution of the BDLC for determining what symbol is being received is equal to a single period of the MUX interface clock (t_{BDLC}), an apparent separation in these maximum time/minimum time concurrences equal to one cycle of t_{BDLC} occurs.

This one clock resolution allows the BDLC to differentiate properly between the different bits and symbols. This is done without reducing the valid window for receiving bits and symbols from transmitters onto the J1850 bus which have varying oscillator frequencies.

In Huntsinger's variable pulse width (VPW) modulation bit encoding, the tolerances for both the passive and active data bits received and the symbols received are defined with no gaps between definitions. For example, the maximum length of a passive logic 0 is equal to the minimum length of a passive logic 1, and the maximum length of an active logic 0 is equal to the minimum length of a valid SOF symbol.

Invalid Passive Bit

See [Figure 24-7\(1\)](#). If the passive-to-active received transition beginning the next data bit or symbol occurs between the active-to-passive transition beginning the current data bit (or symbol) and **a**, the current bit would be invalid.

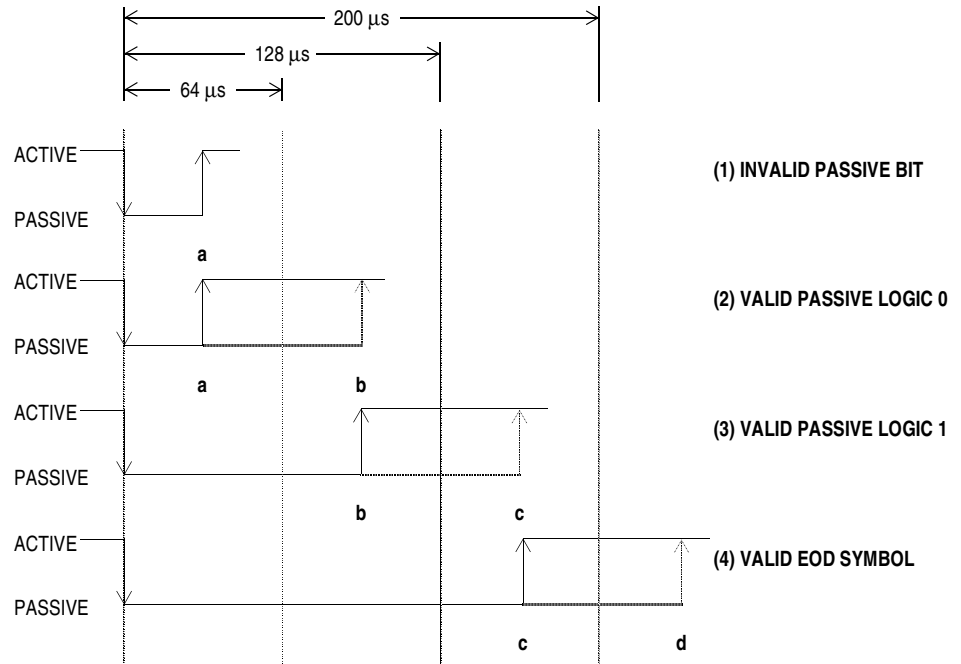

Figure 24-7. J1850 VPW Received Passive Symbol Times

Valid Passive Logic 0

See [Figure 24-7\(2\)](#). If the passive-to-active received transition beginning the next data bit (or symbol) occurs between **a** and **b**, the current bit would be considered a logic 0.

Valid Passive Logic 1

See [Figure 24-7\(3\)](#). If the passive-to-active received transition beginning the next data bit (or symbol) occurs between **b** and **c**, the current bit would be considered a logic 1.

Valid EOD Symbol

See [Figure 24-7\(4\)](#). If the passive-to-active received transition beginning the next data bit (or symbol) occurs between **c** and **d**, the current symbol would be considered a valid end-of-data symbol (EOD).

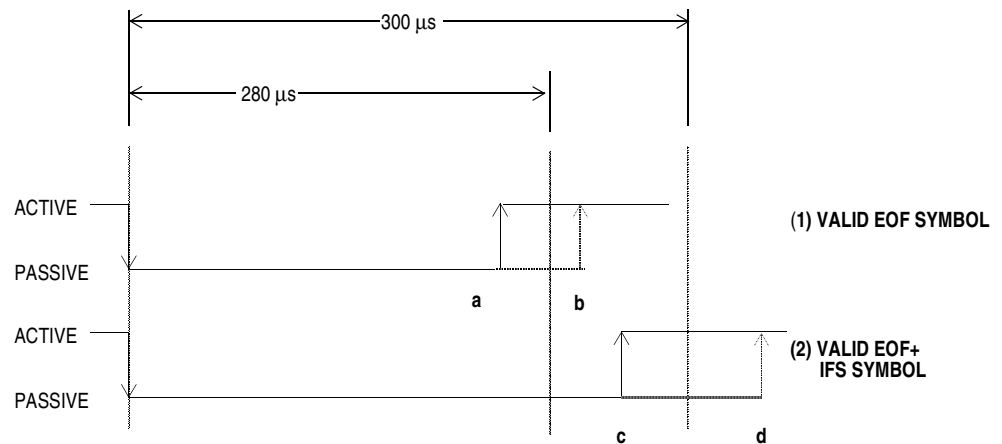

Figure 24-8. J1850 VPW Received Passive EOF and IFS Symbol Times

Valid EOF and IFS Symbol

In [Figure 24-8\(1\)](#), if the passive-to-active received transition beginning the SOF symbol of the next message occurs between **a** and **b**, the current symbol will be considered a valid end-of-frame (EOF) symbol.

See [Figure 24-8\(2\)](#). If the passive-to-active received transition beginning the SOF symbol of the next message occurs between **c** and **d**, the current symbol will be considered a valid EOF symbol followed by a valid inter-frame separation symbol (IFS). All nodes must wait until a valid IFS symbol time has expired before beginning transmission. However, due to variations in clock frequencies and bus loading, some nodes may recognize a valid IFS symbol before others and immediately begin transmitting. Therefore, any time a node waiting to transmit detects a passive-to-active transition once a valid EOF has been detected, it should immediately begin transmission, initiating the arbitration process.

Idle Bus

In [Figure 24-8\(2\)](#), if the passive-to-active received transition beginning the start-of-frame (SOF) symbol of the next message does not occur before **d**, the bus is considered to be idle, and any node wishing to transmit a message may do so immediately.

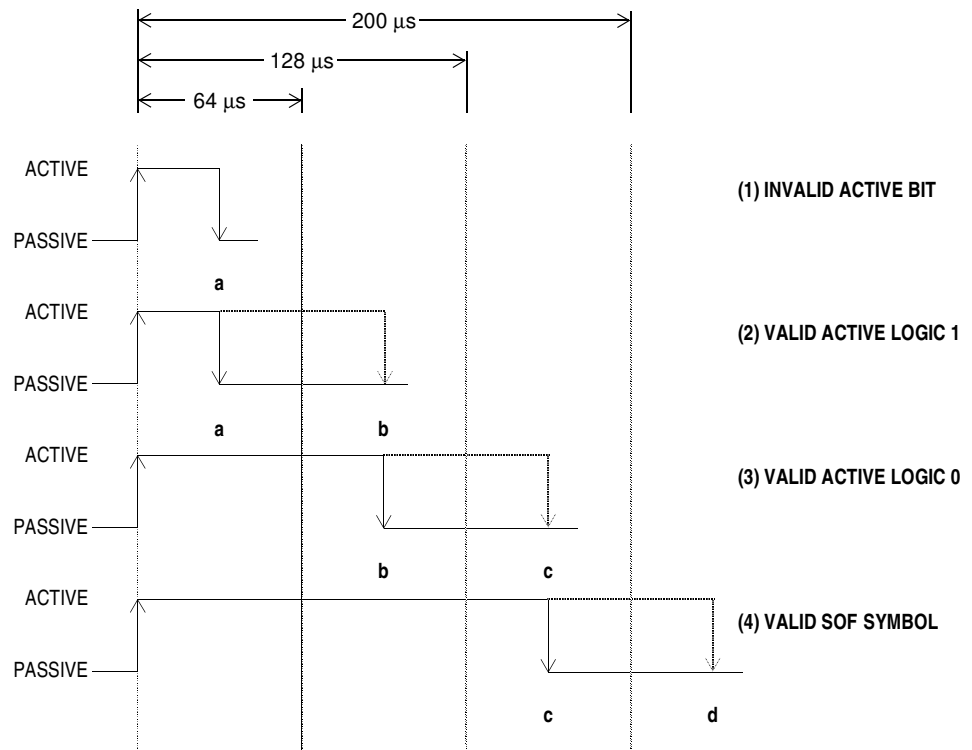

Figure 24-9. J1850 VPW Received Active Symbol Times

Invalid Active Bit

In [Figure 24-9\(1\)](#), if the active-to-passive received transition beginning the next data bit (or symbol) occurs between the passive-to-active transition beginning the current data bit (or symbol) and **a**, the current bit would be invalid.

Valid Active Logic 1

In [Figure 24-9\(2\)](#), if the active-to-passive received transition beginning the next data bit (or symbol) occurs between **a** and **b**, the current bit would be considered a logic 1.

Valid Active Logic 0

In [Figure 24-9\(3\)](#), if the active-to-passive received transition beginning the next data bit (or symbol) occurs between **b** and **c**, the current bit would be considered a logic 0.

Valid SOF Symbol

In [Figure 24-9\(4\)](#), if the active-to-passive received transition beginning the next data bit (or symbol) occurs between **c** and **d**, the current symbol would be considered a valid SOF symbol.

Valid BREAK Symbol

In [Figure 24-10](#), if the next active-to-passive received transition does not occur until after **e**, the current symbol will be considered a valid BREAK symbol. A BREAK symbol should be followed by a start-of-frame (SOF) symbol beginning the next message to be transmitted onto the J1850 bus. See [J1850 Frame Format](#) for BDLC response to BREAK symbols.

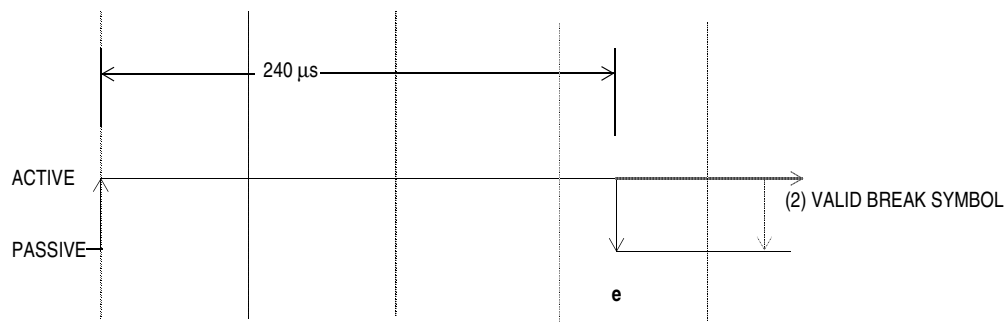

Figure 24-10. J1850 VPW Received BREAK Symbol Times

24.5.5 Message Arbitration

Message arbitration on the J1850 bus is accomplished in a non-destructive manner, allowing the message with the highest priority to be transmitted, while any transmitters which lose arbitration simply stop transmitting and wait for an idle bus to begin transmitting again.

If the BDLC wants to transmit onto the J1850 bus, but detects that another message is in progress, it waits until the bus is idle. However, if multiple nodes begin to transmit in the same synchronization window, message arbitration will occur beginning with the first bit after the SOF symbol and will continue with each bit thereafter.

The variable pulse width modulation (VPW) symbols and J1850 bus electrical characteristics are chosen carefully so that a logic 0 (active or passive type) will always dominate over a logic 1 (active or passive type) that is simultaneously transmitted. Hence, logic 0s are said to be dominant and logic 1s are said to be recessive.

Whenever a node detects a dominant bit on BDRxD when it transmitted a recessive bit, the node loses arbitration and immediately stops transmitting. This is known as bitwise arbitration.

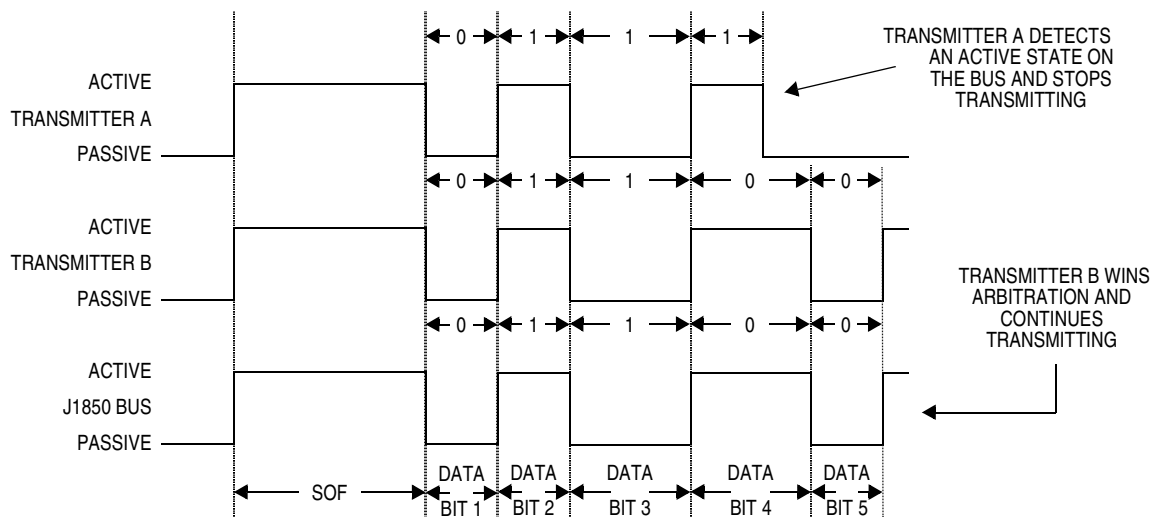

Figure 24-11. J1850 VPW Bitwise Arbitrations

Since a logic 0 dominates a logic 1, the message with the lowest value will have the highest priority and will always win arbitration. For instance, a message with priority 000 will win arbitration over a message with priority 011.

This method of arbitration will work no matter how many bits of priority encoding are contained in the message.

During arbitration, or even throughout the transmitting message, when an opposite bit is detected, transmission is stopped immediately unless it occurs on the 8th bit of a byte. In this case, the BDLC automatically will append up to two extra logic 1 bits and then stop transmitting. These two extra bits will be arbitrated normally and thus will not interfere with

Byte Data Link Controller (BDLC)

another message. The second logic 1 bit will not be sent if the first loses arbitration. If the BDLC has lost arbitration to another valid message, then the two extra logic 1s will not corrupt the current message. However, if the BDLC has lost arbitration due to noise on the bus, then the two extra logic 1s will ensure that the current message will be detected and ignored as a noise-corrupted message.

24.6 BDLC Protocol Handler

The protocol handler is responsible for framing, arbitration, CRC generation/checking, and error detection. The protocol handler conforms to *SAE J1850 — Class B Data Communications Network Interface*.

NOTE: *Motorola assumes that the reader is familiar with the J1850 specification before this protocol handler description is read.*

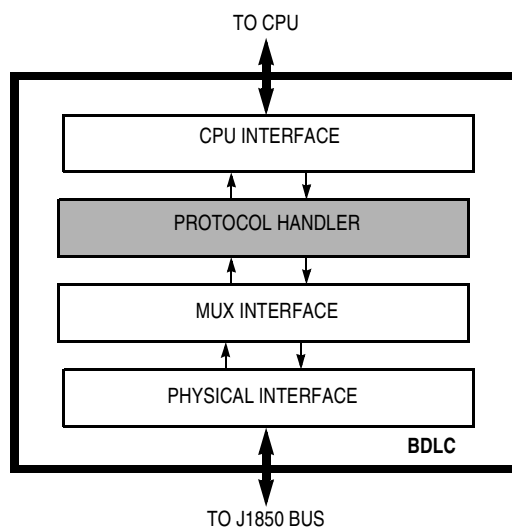

Figure 24-12. BDLC Block Diagram

24.6.1 Protocol Architecture

The protocol handler contains the state machine, Rx shadow register, Tx shadow register, Rx shift register, Tx shift register, and loopback multiplexer as shown in **Figure 24-13**.

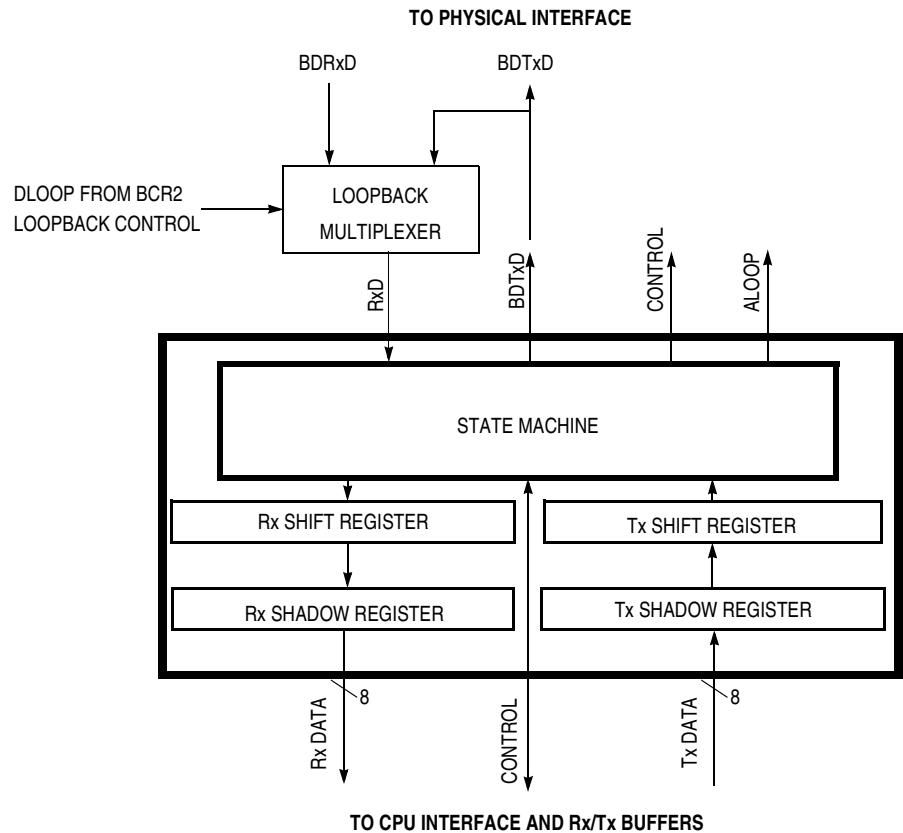

Figure 24-13. BDLC Protocol Handler Outline

24.6.2 Rx and Tx Shift Registers

The Rx shift register gathers received serial data bits from the J1850 bus and makes them available in parallel form to the Rx shadow register. The Tx shift register takes data, in parallel form, from the Tx shadow register and presents it serially to the state machine so that it can be transmitted onto the J1850 bus.

24.6.3 Rx and Tx Shadow Registers

Immediately after the Rx shift register has completed shifting in a byte of data, this data is transferred to the Rx shadow register and RDRF or RXIFR is set (see **BDLC State Vector Register**) and an interrupt is generated if the interrupt enable bit (IE) in BCR1 is set. After the transfer takes place, this new data byte in the Rx shadow register is available to the CPU interface, and the Rx shift register is ready to shift in the next byte of data. Data in the Rx shadow register must be retrieved by the CPU before it is overwritten by new data from the Rx shift register.

Once the Tx shift register has completed its shifting operation for the current byte, the data byte in the Tx shadow register is loaded into the Tx shift register. After this transfer takes place, the Tx shadow register is ready to accept new data from the CPU when TDRE flag in BSVR is set.

24.6.4 Digital Loopback Multiplexer

The digital loopback multiplexer connects RxD to either BDTxD or BDRxD, depending on the state of the DLOOP bit in the BCR2 register (See **BDLC Control Register 2**).

24.6.5 State Machine

All of the functions associated with performing the protocol are executed or controlled by the state machine. The state machine is responsible for framing, collision detection, arbitration, CRC generation/checking, and error detection. The following sections describe the BDLC's actions in a variety of situations.

24.6.5.1 4X Mode

The BDLC can exist on the same J1850 bus as modules which use a special 4X (41.6 kbps) mode of J1850 variable pulse width modulation (VPW) operation. The BDLC cannot transmit in 4X mode, but can receive messages in 4X mode, if the RX4X bit is set in BCR2 register. If the RX4X bit is not set in the BCR2 register, any 4X message on the J1850 bus is treated as noise by the BDLC and is ignored.

24.6.5.2 Receiving a Message in Block Mode

Although not a part of the SAE J1850 protocol, the BDLC does allow for a special block mode of operation of the receiver. As far as the BDLC is concerned, a block mode message is simply a long J1850 frame that contains an indefinite number of data bytes. All of the other features of the frame remain the same, including the SOF, CRC, and EOD symbols.

Another node wishing to send a block mode transmission must first inform all other nodes on the network that this is about to happen. This is usually accomplished by sending a special predefined message.

24.6.5.3 Transmitting a Message in Block Mode

A block mode message is transmitted inherently by simply loading the bytes one by one into the BDR register until the message is complete. The programmer should wait until the TDRE flag (see **BDLC State Vector Register**) is set prior to writing a new byte of data into the BDR register. The BDLC does not contain any predefined maximum J1850 message length requirement.

24.6.5.4 J1850 Bus Errors

The BDLC detects several types of transmit and receive errors which can occur during the transmission of a message onto the J1850 bus.

Transmission Error

If the message transmitted by the BDLC contains invalid bits or framing symbols on non-byte boundaries, this constitutes a transmission error. When a transmission error is detected, the BDLC immediately will cease transmitting. The error condition (\$1C) is reflected in the BSVR register (see **Table 24-6**). If the interrupt enable bit (IE in BCR1) is set, a CPU interrupt request from the BDLC is generated.

CRC Error

A cyclical redundancy check (CRC) error is detected when the data bytes and CRC byte of a received message are processed and the CRC calculation result is not equal to \$C4. The CRC code will detect

any single and 2-bit errors, as well as all 8-bit burst errors and almost all other types of errors. The CRC error flag (\$18 in BSVR) is set when a CRC error is detected. (See [BDLC State Vector Register](#).)

Symbol Error

A symbol error is detected when an abnormal (invalid) symbol is detected in a message being received from the J1850 bus. However, if the BDLC is transmitting when this happens, it will be treated as a loss of arbitration (\$14 in BSVR) rather than a transmitter error. The (\$1C) symbol invalid or the out-of-range flag is set when a symbol error is detected. Therefore, (\$1C) symbol invalid flag is stacked behind the (\$14) LOA flag during a transmission error process. (See [BDLC State Vector Register](#).)

Framing Error

A framing error is detected if an EOD or EOF symbol is detected on a non-byte boundary from the J1850 bus. A framing error also is detected if the BDLC is transmitting the EOD and instead receives an active symbol. The (\$1C) symbol invalid or the out-of-range flag is set when a framing error is detected. (See [BDLC State Vector Register](#).)

Bus Fault

If a bus fault occurs, the response of the BDLC will depend upon the type of bus fault.

If the bus is shorted to battery, the BDLC will wait for the bus to fall to a passive state before it will attempt to transmit a message. As long as the short remains, the BDLC will never attempt to transmit a message onto the J1850 bus.

If the bus is shorted to ground, the BDLC will see an idle bus, begin to transmit the message, and then detect a transmission error (\$1C in BSVR), since the short to ground would not allow the bus to be driven to the active (dominant) SOF state. The BDLC will abort that transmission and wait for the next CPU command to transmit.

In any case, if the bus fault is temporary, as soon as the fault is cleared, the BDLC will resume normal operation. If the bus fault is permanent, it may result in permanent loss of communication on the J1850 bus. (See [BDLC State Vector Register](#).)

BREAK — Break

If a BREAK symbol is received while the BDLC is transmitting or receiving, an invalid symbol (\$1C in BSVR) interrupt will be generated. Reading the BSVR register (see [BDLC State Vector Register](#)) will clear this interrupt condition. The BDLC will wait for the bus to idle, then wait for a start-of-frame (SOF) symbol.

The BDLC cannot transmit a BREAK symbol. It can only receive a BREAK symbol from the J1850 bus.

24.6.5.5 Summary

Table 24-2. BDLC J1850 Bus Error Summary

Error Condition	BDLC Function
Transmission Error	For invalid bits or framing symbols on non-byte boundaries, invalid symbol interrupt will be generated. BDLC stops transmission.
Cyclical Redundancy Check (CRC) Error	CRC error interrupt will be generated. The BDLC will wait for SOF.
Invalid Symbol: BDLC Receives Invalid Bits (Noise)	The BDLC will abort transmission immediately. Invalid symbol interrupt will be generated.
Framing Error	Invalid symbol interrupt will be generated. The BDLC will wait for start-of-frame (SOF).
Bus Short to V_{DD}	The BDLC will not transmit until the bus is idle.
Bus Short to GND	Thermal overload will shut down physical interface. Fault condition is reflected in BSVR as an invalid symbol.
BDLC Receives BREAK Symbol.	The BDLC will wait for the next valid SOF. Invalid symbol interrupt will be generated.

24.7 BDLC CPU Interface

The CPU interface provides the interface between the CPU and the BDLC and consists of five user registers.

- BDLC analog and roundtrip delay register (BARD)
- BDLC control register 1 (BCR1)
- BDLC control register 2 (BCR2)
- BDLC state vector register (BSVR)
- BDLC data register (BDR)

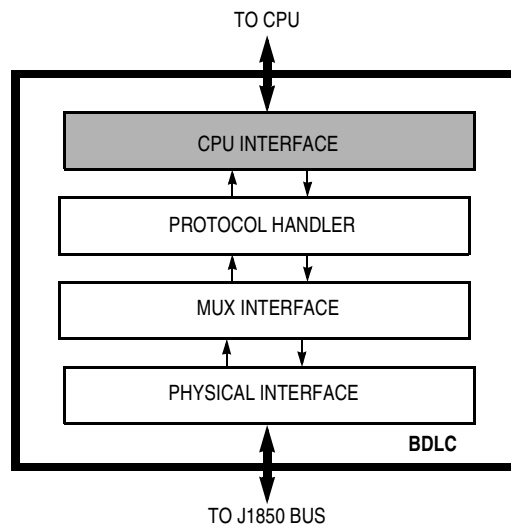

Figure 24-14. BDLC Block Diagram

24.7.1 BDLC Analog and Roundtrip Delay Register

This register programs the BDLC to compensate for various delays of different external transceivers. The default delay value is 16 μ s. Timing adjustments from 9 μ s to 24 μ s in steps of 1 μ s are available. The BARD register can be written only once after each reset, after which they become read-only bits. The register may be read at any time.

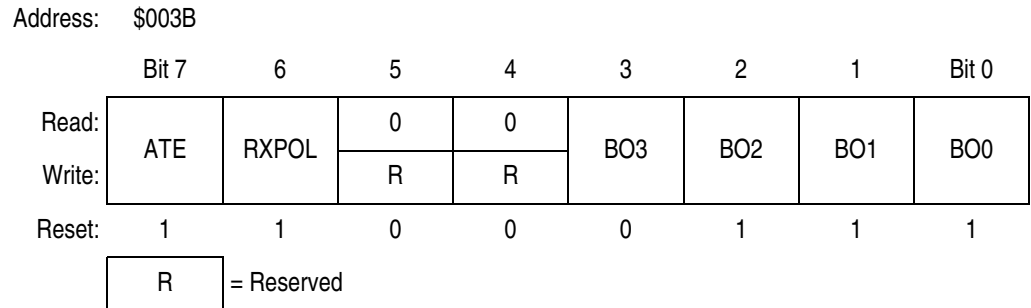

Figure 24-15. BDLC Analog and Roundtrip Delay Register (BARD)

ATE — Analog Transceiver Enable Bit

The analog transceiver enable (ATE) bit is used to select either the on-board or an off-chip analog transceiver.

- 1 = Select on-board analog transceiver
- 0 = Select off-chip analog transceiver

NOTE: *This device does not contain an on-board transceiver. This bit should be programmed to a logic 0 for proper operation.*

RXPOL — Receive Pin Polarity Bit

The receive pin polarity (RXPOL) bit is used to select the polarity of an incoming signal on the receive pin. Some external analog transceivers invert the receive signal from the J1850 bus before feeding it back to the digital receive pin.

- 1 = Select normal/true polarity; true non-inverted signal from the J1850 bus; for example, the external transceiver does not invert the receive signal
- 0 = Select inverted polarity, where an external transceiver inverts the receive signal from the J1850 bus

Byte Data Link Controller (BDLC)

B03–B00 — BARD Offset Bits

Table 24-3 shows the expected transceiver delay with respect to BARD offset values.

Table 24-3. BDLC Transceiver Delay

BARD Offset Bits B0[3:0]	Corresponding Expected Transceiver's Delays (μ s)
0000	9
0001	10
0010	11
0011	12
0100	13
0101	14
0110	15
0111	16
1000	17
1001	18
1010	19
1011	20
1100	21
1101	22
1110	23
1111	24

24.7.2 BDLC Control Register 1

This register is used to configure and control the BDLC.

Address: \$003C

	Bit 7	6	5	4	3	2	1	Bit 0
Read:	IMSG	CLKS	R1	R0	0	0	IE	WCM
Write:					R	R		
Reset:	1	1	1	0	0	0	0	0

R = Reserved

Figure 24-16. BDLC Control Register 1 (BCR1)

IMSG — Ignore Message Bit

This bit is used to disable the receiver until a new start-of-frame (SOF) is detected.

1 = Disable receiver. When set, all BDLC interrupt requests will be masked and the status bits will be held in their reset state. If this bit is set while the BDLC is receiving a message, the rest of the incoming message will be ignored.

0 = Enable receiver. This bit is cleared automatically by the reception of an SOF symbol or a BREAK symbol. It will then generate interrupt requests and will allow changes of the status register to occur. However, these interrupts may still be masked by the interrupt enable (IE) bit.

CLKS — Clock Bit

The nominal BDLC operating frequency (f_{BDLC}) must always be 1.048576 MHz or 1 MHz for J1850 bus communications to take place. The CLKS register bit allows the user to select the frequency (1.048576 MHz or 1 MHz) used to adjust symbol timing automatically.

1 = Binary frequency (1.048576 MHz) selected for f_{BDLC}

0 = Integer frequency (1 MHz) selected for f_{BDLC}

R1 and R0 — Rate Select Bits

These bits determine the amount by which the frequency of the MCU CGMXCLK signal is divided to form the MUX interface clock (f_{BDLC}) which defines the basic timing resolution of the MUX interface. They may be written only once after reset, after which they become read-only bits.

The nominal frequency of f_{BDLC} must always be 1.048576 MHz or 1.0 MHz for J1850 bus communications to take place. Hence, the value programmed into these bits is dependent on the chosen MCU system clock frequency per [Table 24-4](#)

Table 24-4. BDLC Rate Selection

f_{XCLK} Frequency	R1	R0	Division	f_{BDLC}
1.049 MHz	0	0	1	1.049 MHz
2.097 MHz	0	1	2	1.049 MHz
4.194 MHz	1	0	4	1.049 MHz
8.389 MHz	1	1	8	1.049 MHz
1.000 MHz	0	0	1	1.00 MHz
2.000 MHz	0	1	2	1.00 MHz
4.000 MHz	1	0	4	1.00 MHz
8.000 MHz	1	1	8	1.00 MHz

IE— Interrupt Enable Bit

This bit determines whether the BDLC will generate CPU interrupt requests in run mode. It does not affect CPU interrupt requests when exiting the BDLC stop or BDLC wait modes. Interrupt requests will be maintained until all of the interrupt request sources are cleared by performing the specified actions upon the BDLC's registers. Interrupts that were pending at the time that this bit is cleared may be lost.

1 = Enable interrupt requests from BDLC

0 = Disable interrupt requests from BDLC

If the programmer does not wish to use the interrupt capability of the BDLC, the BDLC state vector register (BSVR) can be polled periodically by the programmer to determine BDLC states. See **BDLC State Vector Register** for a description of the BSVR.

WCM — Wait Clock Mode Bit

This bit determines the operation of the BDLC during CPU wait mode. See **Stop Mode** and **Wait Mode** for more details on its use.

1 = Stop BDLC internal clocks during CPU wait mode

0 = Run BDLC internal clocks during CPU wait mode

24.7.3 BDLC Control Register 2

This register controls transmitter operations of the BDLC. It is recommended that BSET and BCLR instructions be used to manipulate data in this register to ensure that the register's content does not change inadvertently.

Address: \$003D

	Bit 7	6	5	4	3	2	1	Bit 0
Read:	ALOOP	DLOOP	RX4XE	NBFS	TEOD	TSIFR	TMIFR1	TMIFR0
Write:								
Reset:	1	1	0	0	0	0	0	0

Figure 24-17. BDLC Control Register 2 (BCR2)

ALOOP — Analog Loopback Mode Bit

This bit determines whether the J1850 bus will be driven by the analog physical interface's final drive stage. The programmer can use this bit to reset the BDLC state machine to a known state after the off-chip analog transceiver is placed in loopback mode. When the user clears ALOOP, to indicate that the off-chip analog transceiver is no longer in loopback mode, the BDLC waits for an EOF symbol before attempting to transmit.

- 1 = Input to the analog physical interface's final drive stage is looped back to the BDLC receiver. The J1850 bus is not driven.
- 0 = The J1850 bus will be driven by the BDLC. After the bit is cleared, the BDLC requires the bus to be idle for a minimum of end-of-frame symbol time (t_{TRV4}) before message reception or a minimum of inter-frame symbol time (t_{TRV6}) before message transmission. (See [BDLC Transmitter VPW Symbol Timings](#).)

DLOOP — Digital Loopback Mode Bit

This bit determines the source to which the digital receive input (BDRxD) is connected and can be used to isolate bus fault conditions (see **Figure 24-13**). If a fault condition has been detected on the bus, this control bit allows the programmer to connect the digital transmit output to the digital receive input. In this configuration, data sent from the transmit buffer will be reflected back into the receive buffer. If no faults exist in the BDLC, the fault is in the physical interface block or elsewhere on the J1850 bus.

1 = When set, BDRxD is connected to BDTxD. The BDLC is now in digital loopback mode.

0 = When cleared, BDTxD is not connected to BDRxD. The BDLC is taken out of digital loopback mode and can now drive the J1850 bus normally.

RX4XE — Receive 4X Enable Bit

This bit determines if the BDLC operates at normal transmit and receive speed (10.4 kbps) or receive only at 41.6 kbps. This feature is useful for fast download of data into a J1850 node for diagnostic or factory programming of the node.

1 = When set, the BDLC is put in 4X receive-only operation.

0 = When cleared, the BDLC transmits and receives at 10.4 kbps.

NBFS — Normalization Bit Format Select Bit

This bit controls the format of the normalization bit (NB). (See **Figure 24-18**.) SAE J1850 strongly encourages using an active long (logic 0) for in-frame responses containing cyclical redundancy check (CRC) and an active short (logic 1) for in-frame responses without CRC.

1 = NB that is received or transmitted is a 0 when the response part of an in-frame response (IFR) ends with a CRC byte. NB that is received or transmitted is a 1 when the response part of an in-frame response (IFR) does not end with a CRC byte.

0 = NB that is received or transmitted is a 1 when the response part of an in-frame response (IFR) ends with a CRC byte. NB that is received or transmitted is a 0 when the response part of an in-frame response (IFR) does not end with a CRC byte.

TEOD — Transmit End of Data Bit

This bit is set by the programmer to indicate the end of a message is being sent by the BDLC. It will append an 8-bit CRC after completing transmission of the current byte. This bit also is used to end an in-frame response (IFR). If the transmit shadow register is full when TEOD is set, the CRC byte will be transmitted after the current byte in the Tx shift register and the byte in the Tx shadow register have been transmitted. (See **Rx and Tx Shadow Registers** for a description of the transmit shadow register.) Once TEOD is set, the transmit data register empty flag (TDRE) in the BDLC state vector register (BSVR) is cleared to allow lower priority interrupts to occur. (See **BDLC State Vector Register**.)

1 = Transmit end-of-data (EOD) symbol

0 = The TEOD bit will be cleared automatically at the rising edge of the first CRC bit that is sent or if an error is detected. When TEOD is used to end an IFR transmission, TEOD is cleared when the BDLC receives back a valid EOD symbol or an error condition occurs.

TSIFR, TMIFR1, and TMIFR0 — Transmit In-Frame Response Control Bits

These three bits control the type of in-frame response being sent. The programmer should not set more than one of these control bits to a 1 at any given time. However, if more than one of these three control bits are set to 1, the priority encoding logic will force these register bits to a known value as shown in **Table 24-5**. For example, if 011 is written to TSIFR, TMIFR1, and TMIFR0, then internally they will be encoded as 010. However, when these bits are read back, they will read 011.

Table 24-5. BDLC Transmit In-Frame Response Control Bit Priority Encoding

Write/Read TSIFR	Write/Read TMIFR1	Write/Read TMIFR0	Actual TSIFR	Actual TMIFR1	Actual TMIFR0
0	0	0	0	0	0
1	X	X	1	0	0
0	1	X	0	1	0
0	0	1	0	0	1

Byte Data Link Controller (BDLC)

The BDLC supports the in-frame response (IFR) feature of J1850 by setting these bits correctly. The four types of J1850 IFR are shown below. The purpose of the in-frame response modes is to allow multiple nodes to acknowledge receipt of the data by responding with their personal ID or physical address in a concatenated manner after they have seen the EOD symbol. If transmission arbitration is lost by a node while sending its response, it continues to transmit its ID/address until observing its unique byte in the response stream. For VPW modulation, because the first bit of the IFR is always passive, a normalization bit (active) must be generated by the responder and sent prior to its ID/address byte. When there are multiple responders on the J1850 bus, only one normalization bit is sent which assists all other transmitting nodes to sync up their response.

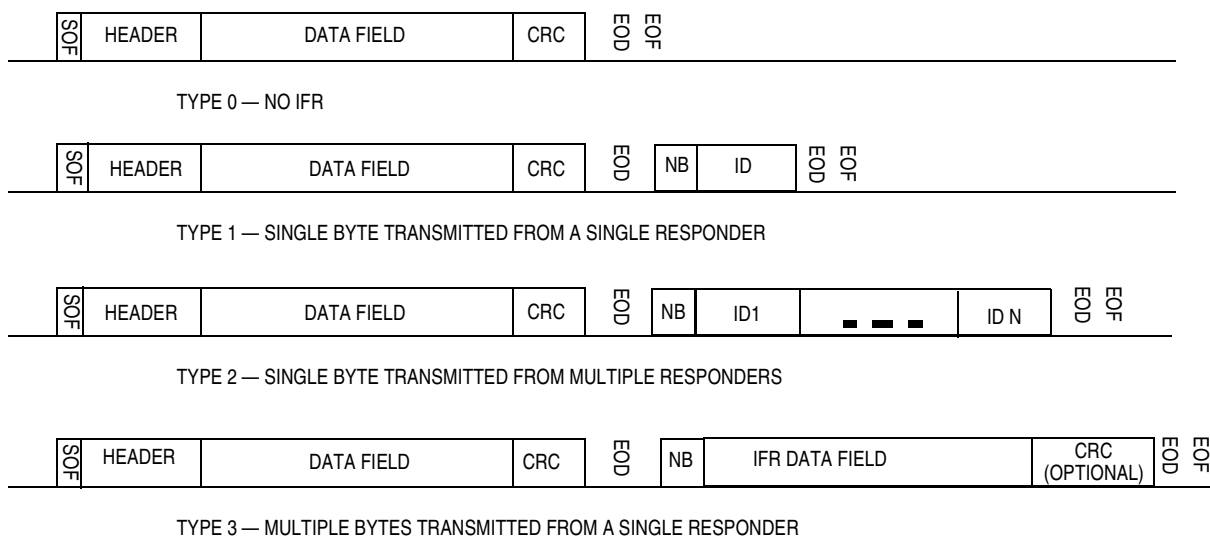

NB = Normalization Bit
 ID = Identifier (usually the physical address of the responder(s))
 HEADER = Specifies one of three frame lengths

Figure 24-18. Types of In-Frame Response (IFR)

TSIFR — Transmit Single Byte IFR with No CRC (Type 1 or 2) Bit

The TSIFR bit is used to request the BDLC to transmit the byte in the BDLC data register (BDR, \$003F) as a single byte IFR with no CRC. Typically, the byte transmitted is a unique identifier or address of the transmitting (responding) node. See [Figure 24-18](#).

1 = If this bit is set prior to a valid EOD being received with no CRC error, once the EOD symbol has been received the BDLC will attempt to transmit the appropriate normalization bit followed by the byte in the BDR.

0 = The TSIFR bit will be cleared automatically, once the BDLC has successfully transmitted the byte in the BDR onto the bus, or TEOD is set, or an error is detected on the bus.

If the programmer attempts to set the TSIFR bit immediately after the EOD symbol has been received from the bus, the TSIFR bit will remain in the reset state and no attempt will be made to transmit the IFR byte.

If a loss of arbitration occurs when the BDLC attempts to transmit and after the IFR byte winning arbitration completes transmission, the BDLC will again attempt to transmit the BDR (with no normalization bit). The BDLC will continue transmission attempts until an error is detected on the bus, or TEOD is set, or the BDLC transmission is successful.

If loss or arbitration occurs in the last two bits of the IFR byte, two additional 1 bits **will not** be sent out because the BDLC will attempt to retransmit the byte in the transmit shift register after the IRF byte winning arbitration completes transmission.

TMIFR1 — Transmit Multiple Byte IFR with CRC (Type 3) Bit

The TMIFR1 bit requests the BDLC to transmit the byte in the BDLC data register (BDR) as the first byte of a multiple byte IFR with CRC or as a single byte IFR with CRC. Response IFR bytes are still subject to J1850 message length maximums (see [J1850 Frame Format](#) and [Figure 24-18](#)).

If this bit is set prior to a valid EOD being received with no CRC error, once the EOD symbol has been received the BDLC will attempt to transmit the appropriate normalization bit followed by IFR bytes. The

programmer should set TEOD after the last IFR byte has been written into the BDR register. After TEOD has been set and the last IFR byte has been transmitted, the CRC byte is transmitted.

0 = The TMIFR1 bit will be cleared automatically – once the BDLC has successfully transmitted the CRC byte and EOD symbol – by the detection of an error on the multiplex bus or by a transmitter underrun caused when the programmer does not write another byte to the BDR after the TDRE interrupt.

If the TMIFR1 bit is set, the BDLC will attempt to transmit the normalization symbol followed by the byte in the BDR. After the byte in the BDR has been loaded into the transmit shift register, a TDRE interrupt (see [BDLC State Vector Register](#)) will occur similar to the main message transmit sequence. The programmer should then load the next byte of the IFR into the BDR for transmission. When the last byte of the IFR has been loaded into the BDR, the programmer should set the TEOD bit in the BDLC control register 2 (BCR2). This will instruct the BDLC to transmit a CRC byte once the byte in the BDR is transmitted and then transmit an EOD symbol, indicating the end of the IFR portion of the message frame.

However, if the programmer wishes to transmit a single byte followed by a CRC byte, the programmer should load the byte into the BDR before the EOD symbol has been received, and then set the TMIFR1 bit. Once the TDRE interrupt occurs, the programmer should then set the TEOD bit in the BCR2. This will result in the byte in the BDR being the only byte transmitted before the IFR CRC byte, and no TDRE interrupt will be generated.

If the programmer attempts to set the TMIFR1 bit immediately after the EOD symbol has been received from the bus, the TMIFR1 bit will remain in the reset state, and no attempt will be made to transmit an IFR byte.

If a loss of arbitration occurs when the BDLC is transmitting any byte of a multiple byte IFR, the BDLC will go to the loss of arbitration state, set the appropriate flag, and cease transmission.

If the BDLC loses arbitration during the IFR, the TMIFR1 bit will be cleared and no attempt will be made to retransmit the byte in the BDR. If loss of arbitration occurs in the last two bits of the IFR byte, two additional 1 bits will be sent out.

NOTE: *The extra logic 1s are an enhancement to the J1850 protocol which forces a byte boundary condition fault. This is helpful in preventing noise from going onto the J1850 bus from a corrupted message.*

TMIFR0 — Transmit Multiple Byte IFR without CRC (Type 3) Bit

The TMIFR0 bit is used to request the BDLC to transmit the byte in the BDLC data register (BDR) as the first byte of a multiple byte IFR without CRC. Response IFR bytes are still subject to J1850 message length maximums (see **J1850 Frame Format** and **Figure 24-18**).

1 = If this bit is set prior to a valid EOD being received with no CRC error, once the EOD symbol has been received the BDLC will attempt to transmit the appropriate normalization bit followed by IFR bytes. The programmer should set TEOD after the last IFR byte has been written into the BDR register. After TEOD has been set, the last IFR byte to be transmitted will be the last byte which was written into the BDR register.

0 = The TMIFR0 bit will be cleared automatically; once the BDLC has successfully transmitted the EOD symbol; by the detection of an error on the multiplex bus; or by a transmitter underrun caused when the programmer does not write another byte to the BDR after the TDRE interrupt.

If the TMIFR0 bit is set, the BDLC will attempt to transmit the normalization symbol followed by the byte in the BDR. After the byte in the BDR has been loaded into the transmit shift register, a TDRE interrupt (see **BDLC State Vector Register**) will occur similar to the main message transmit sequence. The programmer should then load the next byte of the IFR into the BDR for transmission. When the last byte of the IFR has been loaded into the BDR, the programmer should set the TEOD bit in the BCR2. This will instruct the BDLC to transmit an EOD symbol once the byte in the BDR is transmitted, indicating the end of the IFR portion of the message frame. The BDLC will not append a CRC when the TMIFR0 is set.

If the programmer attempts to set the TMIFR0 bit after the EOD symbol has been received from the bus, the TMIFR0 bit will remain in the reset state, and no attempt will be made to transmit an IFR byte.

Byte Data Link Controller (BDLC)

If a loss of arbitration occurs when the BDLC is transmitting, the TMIFR0 bit will be cleared and no attempt will be made to retransmit the byte in the BDR. If loss of arbitration occurs in the last two bits of the IFR byte, two additional 1 bits (active short bits) will be sent out.

NOTE: *The extra logic 1s are an enhancement to the J1850 protocol which forces a byte boundary condition fault. This is helpful in preventing noise from going onto the J1850 bus from a corrupted message.*

24.7.4 BDLC State Vector Register

This register is provided to substantially decrease the CPU overhead associated with servicing interrupts while under operation of a multiplex protocol. It provides an index offset that is directly related to the BDLC's current state, which can be used with a user-supplied jump table to rapidly enter an interrupt service routine. This eliminates the need for the user to maintain a duplicate state machine in software.

Address: \$003E

	Bit 7	6	5	4	3	2	1	Bit 0
Read:	0	0	I3	I2	I1	I0	0	0
Write:	R	R	R	R	R	R	R	R
Reset:	0	0	0	0	0	0	0	0

R

 = Reserved

Figure 24-19. BDLC State Vector Register (BSVR)

I0, I1, I2, and I3 — Interrupt Source Bits

These bits indicate the source of the interrupt request that currently is pending. The encoding of these bits are listed in [Table 24-6](#).

Table 24-6. BDLC Interrupt Sources

BSVR	I3	I2	I1	I0	Interrupt Source	Priority
\$00	0	0	0	0	No Interrupts Pending	0 (Lowest)
\$04	0	0	0	1	Received EOF	1
\$08	0	0	1	0	Received IFR Byte (RXIFR)	2
\$0C	0	0	1	1	BDLC Rx Data Register Full (RDRF)	3
\$10	0	1	0	0	BDLC Tx Data Register Empty (TDRE)	4
\$14	0	1	0	1	Loss of Arbitration	5
\$18	0	1	1	0	Cyclical Redundancy Check (CRC) Error	6
\$1C	0	1	1	1	Symbol Invalid or Out of Range	7
\$20	1	0	0	0	Wakeup	8 (Highest)

Bits I0, I1, I2, and I3 are cleared by a read of the BSVR except when the BDLC data register needs servicing (RDRF, RXIFR, or TDRE conditions). RXIFR and RDRF can be cleared only by a read of the BSVR followed by a read of the BDLC data register (BDR). TDRE can either be cleared by a read of the BSVR followed by a write to the BDLC BDR or by setting the TEOD bit in BCR2.

Upon receiving a BDLC interrupt, the user can read the value within the BSVR, transferring it to the CPU's index register. The value can then be used to index into a jump table, with entries four bytes apart, to quickly enter the appropriate service routine. For example:

```

Service      LDX   BSVR      Fetch State Vector Number
              JMP   JMPTAB,X  Enter service routine,
*              (must end in RTI)
*
JMPTAB      JMP   SERVE0   Service condition #0
              NOP
              JMP   SERVE1   Service condition #1
              NOP
              JMP   SERVE2   Service condition #2
              NOP
*
              JMP   SERVE8   Service condition #8
              END

```

NOTE: *The NOPs are used only to align the JMPs onto 4-byte boundaries so that the value in the BSVR can be used intact. Each of the service routines must end with an RTI instruction to guarantee correct continued operation of the device. Note also that the first entry can be omitted since it corresponds to no interrupt occurring.*

The service routines should clear all of the sources that are causing the pending interrupts. Note that the clearing of a high priority interrupt may still leave a lower priority interrupt pending, in which case bits I0, I1, and I2 of the BSVR will then reflect the source of the remaining interrupt request.

If fewer states are used or if a different software approach is taken, the jump table can be made smaller or omitted altogether.

24.7.5 BDLC Data Register

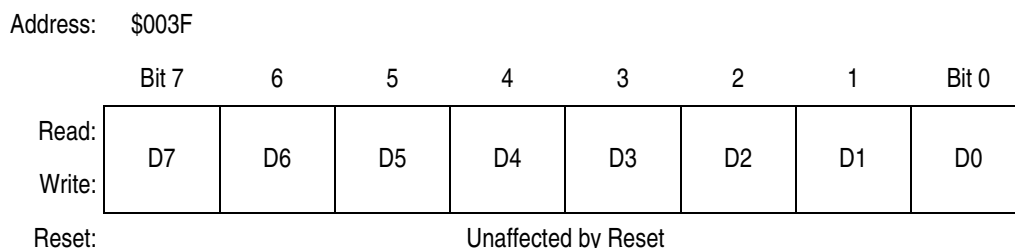

Figure 24-20. BDLC Data Register (BDR)

This register is used to pass the data to be transmitted to the J1850 bus from the CPU to the BDLC. It is also used to pass data received from the J1850 bus to the CPU. Each data byte (after the first one) should be written only after a Tx data register empty (TDRE) state is indicated in the BSVR.

Data read from this register will be the last data byte received from the J1850 bus. This received data should only be read after an Rx data register full (RDRF) interrupt has occurred. (See [BDLC State Vector Register](#).)

The BDR is double buffered via a transmit shadow register and a receive shadow register. After the byte in the transmit shift register has been transmitted, the byte currently stored in the transmit shadow register is loaded into the transmit shift register. Once the transmit shift register has shifted the first bit out, the TDRE flag is set, and the shadow register is ready to accept the next data byte. The receive shadow register works similarly. Once a complete byte has been received, the receive shift register stores the newly received byte into the receive shadow register. The RDRF flag is set to indicate that a new byte of data has been received. The programmer has one BDLC byte reception time to read the shadow register and clear the RDRF flag before the shadow register is overwritten by the newly received byte.

To abort an in-progress transmission, the programmer should stop loading data into the BDR. This will cause a transmitter underrun error and the BDLC automatically will disable the transmitter on the next non-byte boundary. This means that the earliest a transmission can be halted is after at least one byte plus two extra logic 1s have been transmitted. The receiver will pick this up as an error and relay it in the state vector register as an invalid symbol error.

NOTE: *The extra logic 1s are an enhancement to the J1850 protocol which forces a byte boundary condition fault. This is helpful in preventing noise from going onto the J1850 bus from a corrupted message.*

24.8 Low-Power Modes

The following information concerns wait mode and stop mode.

24.8.1 Wait Mode

This power-conserving mode is entered automatically from run mode whenever the CPU executes a WAIT instruction and the WCM bit in BDLC control register 1 (BCR1) is previously clear. In BDLC wait mode, the BDLC cannot drive any data.

A subsequent successfully received message, including one that is in progress at the time that this mode is entered, will cause the BDLC to

wake up and generate a CPU interrupt request if the interrupt enable (IE) bit in the BDLC control register 1 (BCR1) is previously set. (See **BDLC Control Register 1** for a better understanding of IE.) This results in less of a power saving, but the BDLC is guaranteed to receive correctly the message which woke it up, since the BDLC internal operating clocks are kept running.

NOTE: *Ensuring that all transmissions are complete or aborted before putting the BDLC into wait mode is important.*

24.8.2 Stop Mode

This power-conserving mode is entered automatically from run mode whenever the CPU executes a STOP instruction or if the CPU executes a WAIT instruction and the WCM bit in the BDLC control register 1 (BCR1) is previously set. This is the lowest power mode that the BDLC can enter.

A subsequent passive-to-active transition on the J1850 bus will cause the BDLC to wake up and generate a non-maskable CPU interrupt request. When a STOP instruction is used to put the BDLC in stop mode, the BDLC is not guaranteed to correctly receive the message which woke it up, since it may take some time for the BDLC internal operating clocks to restart and stabilize. If a WAIT instruction is used to put the BDLC in stop mode, the BDLC is guaranteed to correctly receive the byte which woke it up, if and only if an end-of-frame (EOF) has been detected prior to issuing the WAIT instruction by the CPU. Otherwise, the BDLC will not correctly receive the byte that woke it up.

If this mode is entered while the BDLC is receiving a message, the first subsequent received edge will cause the BDLC to wake up immediately, generate a CPU interrupt request, and wait for the BDLC internal operating clocks to restart and stabilize before normal communications can resume. Therefore, the BDLC is not guaranteed to receive that message correctly.

NOTE: *It is important to ensure all transmissions are complete or aborted prior to putting the BDLC into stop mode.*

Section 25. Electrical Specification

25.1 Contents

25.2	Electrical Specifications	420
25.2.1	Maximum Ratings	420
25.2.2	Functional Operating Range	421
25.2.3	Thermal Characteristics	421
25.2.4	5.0 Volt DC Electrical Characteristics	422
25.2.5	Control Timing	423
25.2.6	ADC Characteristics	424
25.2.7	5.0 Vdc \pm 0.5 V Serial Peripheral Interface (SPI) Timing	425
25.2.8	CGM Operating Conditions	428
25.2.9	CGM Component Information	428
25.2.10	CGM Acquisition/Lock Time Information	429
25.2.11	Timer Module Characteristics	430
25.2.12	RAM Memory Characteristics	430
25.2.13	EEPROM Memory Characteristics	432
25.2.14	FLASH Memory Characteristics	432
25.2.15	BDLC Transmitter VPW Symbol Timings	432
25.2.16	BDLC Receiver VPW Symbol Timings	432
25.2.17	BDLC Transmitter DC Electrical Characteristics	433
25.2.18	BDLC Receiver DC Electrical Characteristics	433
25.3	Mechanical Specifications	434
25.3.1	52-pin Plastic Leaded Chip Carrier (PLCC)	434

25.2 Electrical Specifications

25.2.1 Maximum Ratings

Maximum ratings are the extreme limits to which the MCU can be exposed without permanently damaging it.

NOTE: *This device is not guaranteed to operate properly at the maximum ratings. Refer to [5.0 Volt DC Electrical Characteristics](#) on page 422 for guaranteed operating conditions.*

Rating	Symbol	Value	Unit
Supply Voltage	V_{DD}	-0.3 to +6.0	V
Input Voltage	V_{IN}	$V_{SS} - 0.3$ to $V_{DD} + 0.3$	V
Maximum Current Per Pin Excluding V_{DD} and V_{SS}	I	± 25	mA
Storage Temperature	T_{STG}	-55 to +150	°C
Maximum Current out of V_{SS}	I_{MVSS}	100	mA
Maximum Current into V_{DD}	I_{MVDD}	100	mA
Reset and \overline{IRQ} Input Voltage	V_{HI}	$V_{DD} + 4.5$	V

NOTE: Voltages are referenced to V_{SS} .

NOTE: *This device contains circuitry to protect the inputs against damage due to high static voltages or electric fields; however, it is advised that normal precautions be taken to avoid application of any voltage higher than maximum-rated voltages to this high-impedance circuit. For proper operation, it is recommended that V_{IN} and V_{OUT} be constrained to the range $V_{SS} \leq (V_{IN} \text{ or } V_{OUT}) \leq V_{DD}$. Reliability of operation is enhanced if unused inputs are connected to an appropriate logic voltage level (for example, either V_{SS} or V_{DD}).*

25.2.2 Functional Operating Range

Rating	Symbol	Value	Unit
Operating Temperature Range ⁽¹⁾	T_A	-40 to $T_A(\text{MAX})$	°C
Operating Voltage Range	V_{DD}	$5.0 \pm 0.5\text{v}$	V

1. $T_A(\text{MAX}) = 125^\circ\text{C}$ for part suffix MFN
 $T_A(\text{MAX}) = 105^\circ\text{C}$ for part suffix VFN
 $T_A(\text{MAX}) = 85^\circ\text{C}$ for part suffix CFN

NOTE: For applications which use the LVI, Motorola guarantee the functionality of the device CPU only down to the LVI trip point (V_{LVI}) within the constraints outlined in **Low Voltage Inhibit (LVI)**.

25.2.3 Thermal Characteristics

Characteristic	Symbol	Value	Unit
Thermal Resistance QFP (64 Pins)	θ_{JA}	70	°C/W
Thermal Resistance PLCC (52 Pins)	θ_{JA}	50	°C/W
I/O Pin Power Dissipation	$P_{I/O}$	User Determined	W
Power Dissipation (see Note 1)	P_D	$P_D = (I_{DD} \times V_{DD}) +$ $P_{I/O} = K/(T_J + 273 \text{ }^\circ\text{C})$	W
Constant (see Note 2)	K	$P_D \times (T_A + 273 \text{ }^\circ\text{C})$ $+ (P_D^2 \times \theta_{JA})$	W/°C
Average Junction Temperature	T_J	$T_A + P_D \times \theta_{JA}$	°C

NOTES:

- Power dissipation is a function of temperature.
- K is a constant unique to the device. K can be determined from a known T_A and measured P_D . With this value of K, P_D and T_J can be determined for any value of T_A .

Electrical Specification

25.2.4 5.0 Volt DC Electrical Characteristics

Characteristic	Symbol	Min	Typical	Max	Unit
Output High Voltage ($I_{LOAD} = -2.0$ mA) All Ports ($I_{LOAD} = -5.0$ mA) All Ports	V_{OH}	$V_{DD} - 0.8$ $V_{DD} - 1.5$	---	—	V V
Total source current	$I_{OH}(TOT)$	—	---	10	mA
Output Low Voltage ($I_{LOAD} = 1.6$ mA) All Ports ($I_{LOAD} = 10.0$ mA) All Ports	V_{OL}	—	---	0.4 1.5	V V
Total sink current	$I_{OL}(TOT)$	—	---	15	mA
Input High Voltage All Ports, \overline{IRQS} , RESET, OSC1	V_{IH}	$0.7 \times V_{DD}$	---	V_{DD}	V
Input Low Voltage All Ports, \overline{IRQS} , RESET, OSC1	V_{IL}	V_{SS}	---	$0.3 \times V_{DD}$	V
V_{DD} Supply Current Run (see Note 2) Wait (see Note 3) Stop (see Note 4) LVI enabled, $T_A = 25$ °C LVI disabled, $T_A = 25$ °C LVI enabled, -40 °C to $+125$ °C LVI disabled, -40 °C to $+125$ °C	I_{DD}	— — — — — —	25 14 100 35	35 20 400 50 500 100	mA mA μ A μ A μ A μ A
I/O Ports Hi-Z Leakage Current	I_L	-1		1	μ A
Input Current	I_{IN}	-1		1	μ A
Capacitance Ports (As Input or Output)	C_{OUT} C_{IN}	— —		12 8	pF
Low-Voltage Reset Inhibit (trip) (recover)	V_{LVI}	3.80		4.49	V
POR ReArm Voltage (see Note 5)	V_{POR}	0		200	mV
POR Reset Voltage (see Note 6)	V_{PORRST}	0		800	mV
POR Rise Time Ramp Rate (see Note 7)	R_{POR}	0.02		—	V/ms
High COP Disable Voltage (see Note 8)	V_{HI}	$V_{DD} + 3.0$		$V_{DD} + 4.5$	V
Monitor mode entry voltage on \overline{IRQ} (see Note 10)	V_{HI}	$V_{DD} + 3.0$		$V_{DD} + 4.5$	V

Characteristic	Symbol	Min	Typical	Max	Unit
----------------	--------	-----	---------	-----	------

NOTES:

- $V_{DD} = 5.0 \text{ Vdc} \pm 10\%$, $V_{SS} = 0 \text{ Vdc}$, $T_A = -40 \text{ }^\circ\text{C}$ to $+T_A(\text{MAX})$, unless otherwise noted.
- Run (Operating) I_{DD} measured using external square wave clock source ($f_{BUS} = 8.4 \text{ MHz}$). All inputs 0.2 V from rail. No dc loads. Less than 100 pF on all outputs. $C_L = 20 \text{ pF}$ on OSC2. All ports configured as inputs. OSC2 capacitance linearly affects run I_{DD} . Measured with all modules enabled. Typical values at midpoint of voltage range, 25C only.
- Wait I_{DD} measured using external square wave clock source ($f_{BUS} = 8.4 \text{ MHz}$). All inputs 0.2 Vdc from rail. No dc loads. Less than 100 pF on all outputs, $C_L = 20 \text{ pF}$ on OSC2. All ports configured as inputs. OSC2 capacitance linearly affects wait I_{DD} . Measured with all modules enabled. Typical values at midpoint of voltage range, 25C only.
- Stop I_{DD} measured with $\text{OSC1} = V_{SS}$. Typical values at midpoint of voltage range, 25C only.
- Maximum is highest voltage that POR is guaranteed.
- Maximum is highest voltage that POR is possible.
- If minimum V_{DD} is not reached before the internal POR reset is released, RST must be driven low externally until minimum V_{DD} is reached.
- See **COP Module During Break Interrupts** on page 180. V_{HI} applied to $\overline{\text{RST}}$.
- Although I_{DD} is proportional to bus frequency, a current of several mA is present even at very low frequencies.
- See Monitor mode description within **Computer Operating Properly (COP)**. V_{HI} applied to IRQ or RST

25.2.5 Control Timing

Characteristic	Symbol	Min	Max	Unit
Bus Operating Frequency (4.5–5.5 V — V_{DD} Only)	f_{BUS}	—	8.4	MHz
$\overline{\text{RESET}}$ Pulse Width Low	t_{RL}	1.5	—	t_{cyc}
$\overline{\text{IRQ}}$ Interrupt Pulse Width Low (Edge-Triggered)	t_{ILHI}	1.5	—	t_{cyc}
$\overline{\text{IRQ}}$ Interrupt Pulse Period	t_{ILIL}	Note 4	—	t_{cyc}
16-Bit Timer (see Note 2) Input Capture Pulse Width (see Note 3) Input Capture Period	t_{TH}, t_{TL} t_{TLTL}	2 Note 4	— —	t_{cyc}

NOTES:

- $V_{DD} = 5.0 \text{ Vdc} \pm 0.5\text{v}$, $V_{SS} = 0 \text{ Vdc}$, $T_A = -40 \text{ }^\circ\text{C}$ to $T_A(\text{MAX})$, unless otherwise noted.
- The 2-bit timer prescaler is the limiting factor in determining timer resolution.
- Refer to **Table 22-2** and supporting note.
- The minimum period t_{TLTL} or t_{ILIL} should not be less than the number of cycles it takes to execute the capture interrupt service routine plus TBD t_{cyc} .

Electrical Specification

25.2.6 ADC Characteristics

Characteristic	Min	Max	Unit	Comments
Resolution	8	8	Bits	
Absolute Accuracy ($V_{REFL} = 0\text{ V}$, $V_{DDA}/V_{DDAREF} = V_{REFH} = 5\text{ V} \pm 0.5\text{v}$)	-1	+1	LSB	Includes Quantization
Conversion Range (see Note 1)	V_{REFL}	V_{REFH}	V	$V_{REFL} = V_{SSA}$
Power-Up Time	16	17	μs	Conversion Time Period
Input Leakage (see Note 3) Ports B and D	-1	1	μA	
Conversion Time	16	17	ADC Clock Cycles	Includes Sampling Time
Monotonicity	Inherent within Total Error			
Zero Input Reading	00	01	Hex	$V_{IN} = V_{REFL}$
Full-Scale Reading	FE	FF	Hex	$V_{IN} = V_{REFH}$
Sample Time (see Note 2)	5	—	ADC Clock Cycles	
Input Capacitance	—	8	pF	Not Tested
ADC Internal Clock	500 k	1.048 M	Hz	Tested Only at 1 MHz
Analog Input Voltage	V_{REFL}	V_{REFH}	V	

NOTES:

- $V_{DD} = 5.0\text{ Vdc} \pm 0.5\text{v}$, $V_{SS} = 0\text{ Vdc}$, $V_{DDA}/V_{DDAREF} = 5.0\text{ Vdc} \pm 0.5\text{v}$, $V_{SSA} = 0\text{ Vdc}$, $V_{REFH} = 5.0\text{ Vdc} \pm 0.5\text{v}$
- Source impedances greater than 10 k Ω adversely affect internal RC charging time during input sampling.
- The external system error caused by input leakage current is approximately equal to the product of R source and input current.

25.2.7 5.0 Vdc ± 0.5 V Serial Peripheral Interface (SPI) Timing

Num	Characteristic	Symbol	Min	Max	Unit
	Operating Frequency (see Note 3) Master Slave	$f_{BUS(M)}$ $f_{BUS(S)}$	$f_{BUS}/128$ dc	$f_{BUS}/2$ f_{BUS}	MHz
1	Cycle Time Master Slave	$t_{cyc(M)}$ $t_{cyc(S)}$	2 1	128 —	t_{cyc}
2	Enable Lead Time	t_{Lead}	15	—	ns
3	Enable Lag Time	t_{Lag}	15	—	ns
4	Clock (SCK) High Time Master Slave	$t_{W(SCKH)M}$ $t_{W(SCKH)S}$	100 50	— —	ns
5	Clock (SCK) Low Time Master Slave	$t_{W(SCKL)M}$ $t_{W(SCKL)S}$	100 50	— —	ns
6	Data Setup Time (Inputs) Master Slave	$t_{SU(M)}$ $t_{SU(S)}$	45 5	— —	ns
7	Data Hold Time (Inputs) Master Slave	$t_{H(M)}$ $t_{H(S)}$	0 15	— —	ns
8	Access Time, Slave (see Note 4) CPHA = 0 CPHA = 1	$t_{A(CP0)}$ $t_{A(CP1)}$	0 0	40 20	ns
9	Slave Disable Time (Hold Time to High-Impedance State)	t_{DIS}	—	25	ns
10	Enable Edge Lead Time to Data Valid (see Note 6) Master Slave	$t_{EV(M)}$ $t_{EV(S)}$	— —	10 40	ns
11	Data Hold Time (Outputs, after Enable Edge) Master Slave	$t_{HO(M)}$ $t_{HO(S)}$	0 5	— —	ns
12	Data Valid Master (Before Capture Edge)	$t_{V(M)}$	90	—	ns
13	Data Hold Time (Outputs) Master (Before Capture Edge)	$t_{HO(M)}$	100	—	ns

NOTES:

1. All timing is shown with respect to 30% V_{DD} and 70% V_{DD} , unless otherwise noted; assumes 100 pF load on all SPI pins.
2. Item numbers refer to dimensions in [Figure 25-1](#) and [Figure 25-2](#).
3. f_{BUS} = the currently active bus frequency for the microcontroller.
4. Time to data active from high-impedance state.
5. With 100 pF on all SPI pins

Electrical Specification

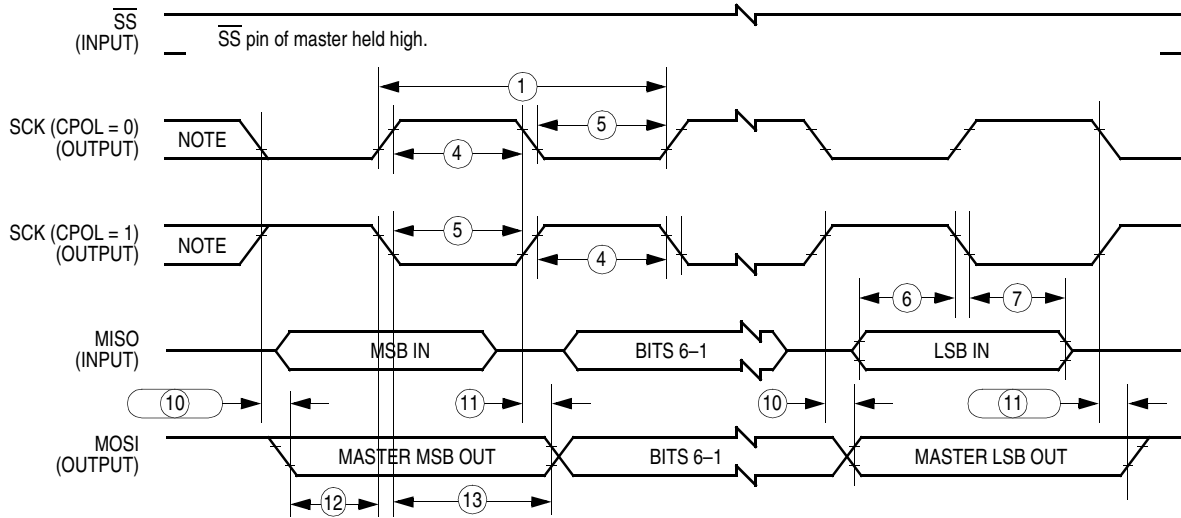

NOTE: This first clock edge is generated internally, but is not seen at the SCK pin.

a) SPI Master Timing (CPHA = 0)

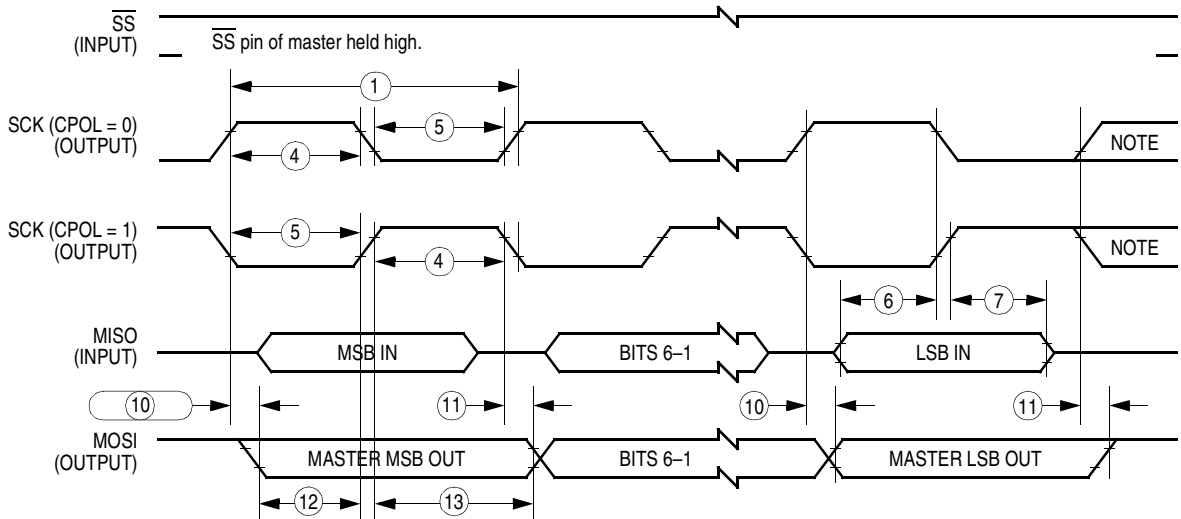

NOTE: This last clock edge is generated internally, but is not seen at the SCK pin.

b) SPI Master Timing (CPHA = 1)

Figure 25-1. SPI Master Timing Diagram

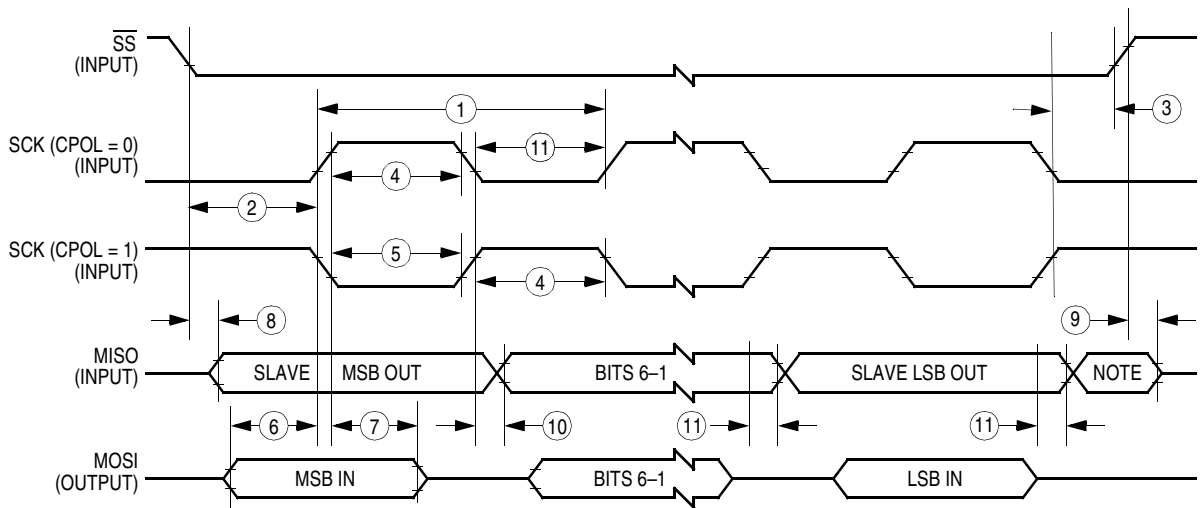

NOTE: Not defined but normally MSB of character just received

a) SPI Slave Timing (CPHA = 0)

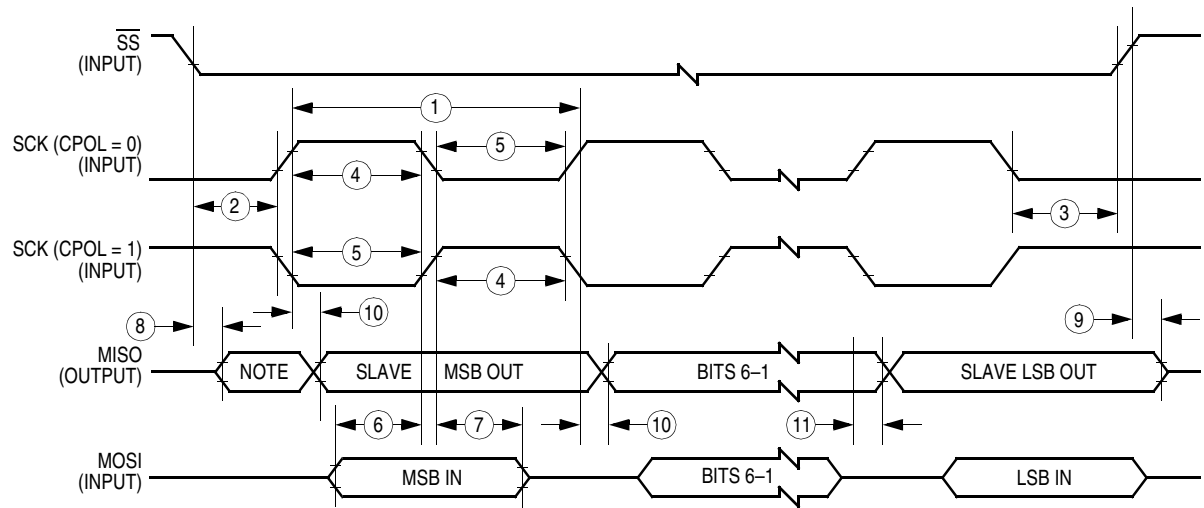

NOTE: Not defined but normally LSB of character previously transmitted

b) SPI Slave Timing (CPHA = 1)

Figure 25-2. SPI Slave Timing Diagram

25.2.8 CGM Operating Conditions

Characteristic	Symbol	Min	Typ	Max	Unit	Comments
Operating Voltage	V_{DDA}	$V_{DD}-0.3$	—	$V_{DD}+0.3$	V	
	V_{SSA}	$V_{SS}-0.3$	—	$V_{SS}+0.3$	V	
Crystal Reference Frequency	$f_{CGMRCLK}$	1	4.9152	16	MHz	
Module Crystal Reference Frequency	$f_{CGMXCLK}$	—	4.9152	—	MHz	Same Frequency as $f_{CGMRCLK}$
Range Nom. Multiplier	f_{NOM}	—	4.9152	—	MHz	
VCO Center-of-Range Frequency	f_{CGMVRS}	4.9152	—	Note 1	MHz	
VCO Operating Frequency	$f_{CGMVCLK}$	4.9152	—	32.0		

1. f_{CGMVRS} is a nominal value described and calculated as an example in the [Clock Generator Module \(CGM\)](#) section for the desired VCO operating frequency, $f_{CGMVCLK}$.

25.2.9 CGM Component Information

Description	Symbol	Min	Typ	Max	Unit	Comments
Crystal Load Capacitance	C_L	—	—	—	—	Consult Crystal Manufacturer's Data
Crystal Fixed Capacitance	C_1	—	2 x C_L	—	—	Consult Crystal Manufacturer's Data
Crystal Tuning Capacitance	C_2	—	2 x C_L	—	—	Consult Crystal Manufacturer's Data
Filter Capacitor Multiply Factor	C_{fact}	—	0.0154	—	F/s V	
Filter Capacitor	C_F	—	$C_{FACT} \times (V_{DDA}/f_{XCLK})$	—	—	See External Filter Capacitor Pin (CGMXFC) on page 135
Bypass Capacitor	C_{BYP}	—	0.1	—	μF	CBYP must provide low AC impedance from $f = f_{CGMXCLK}/100$ to $100 \times f_{CGMVCLK}$, so series resistance must be considered.

25.2.10 CGM Acquisition/Lock Time Information

Description	Symbol	Min	Typ	Max	Unit	Notes
Manual Mode Time to Stable	t_{ACQ}	—	$(8 \times V_{DDA}) / (f_{CGMXCLK} \times K_{ACQ})$	—	s	If C_F Chosen Correctly
Manual Stable to Lock Time	t_{AL}	—	$(4 \times V_{DDA}) / (f_{CGMXCLK} \times K_{TRK})$	—	s	If C_F Chosen Correctly
Manual Acquisition Time	t_{LOCK}	—	$t_{ACQ} + t_{AL}$	—	s	
Tracking Mode Entry Frequency Tolerance	D_{TRK}	0	—	± 3.6	%	
Acquisition Mode Entry Frequency Tolerance	D_{UNT}	± 6.3	—	± 7.2	%	
LOCK Entry Freq. Tolerance	D_{LOCK}	0	—	± 0.9	%	
LOCK Exit Freq. Tolerance	D_{UNL}	± 0.9	—	± 1.8	%	
Reference Cycles per Acquisition Mode Measurement	n_{ACQ}	—	32	—	—	
Reference Cycles per Tracking Mode Measurement	n_{TRK}	—	128	—	—	
Automatic Mode Time to Stable	t_{ACQ}	n_{ACQ}/f_{XCLK}	$(8 \times V_{DDA}) / (f_{XCLK} \times K_{ACQ})$	—	s	If C_F Chosen Correctly
Automatic Stable to Lock Time	t_{AL}	n_{TRK}/f_{XCLK}	$(4 \times V_{DDA}) / (f_{XCLK} \times K_{TRK})$	—	s	If C_F Chosen Correctly
Automatic Lock Time	t_{LOCK}	—	0.65	25	ms	
PLL Jitter, Deviation of Average Bus Frequency over 2 ms (note 1)		0	—	$\pm (f_{CRYS}) \times (.025\%) \times (N/4)$	%	N = VCO Freq. Mult.
K value for automatic mode time to stable	K_{acq}	—	0.2	—	—	
K value	K_{trk}	—	0.004	—	—	

NOTES:

1. Guaranteed but not tested.
2. $V_{DD} = 5.0 \text{ Vdc} \pm 0.5 \text{ V}$, $V_{SS} = 0 \text{ Vdc}$, $T_A = -40\text{C}$ to $T_A \text{ (MAX)}$, unless otherwise noted.
3. Conditions for typical and maximum values are for Run mode with $f_{CGMXCLK} = 8\text{MHz}$, $f_{BUSDES} = 8\text{MHz}$, $N = 4$, $L = 7$, discharged $C_F = 15 \text{ nF}$, $V_{DD} = 5\text{Vdc}$.
4. Refer to Phase-Locked Loop (PLL) section for guidance on the use of the PLL.

Electrical Specification

25.2.11 Timer Module Characteristics

Characteristic	Symbol	Min	Max	Unit
Input Capture Pulse Width	t_{TIH}, t_{TIL}	125	—	ns
Input Clock Pulse Width	t_{TCH}, t_{TCL}	$(1/f_{OP}) + 5$	—	ns

25.2.12 RAM Memory Characteristics

Characteristic	Symbol	Min	Max	Unit
RAM Data Retention Voltage	V_{RDR}	0.7	—	V

25.2.13 EEPROM Memory Characteristics

Characteristic	Symbol	Min	Max	Unit
EEPROM Programming Time per Byte	t_{EEPGM}	10	—	ms
EEPROM Erasing Time per Byte	t_{EEBYTE}	10	—	ms
EEPROM Erasing Time per Block	$t_{EEBLOCK}$	10	—	ms
EEPROM Erasing Time per Bulk	t_{EEBULK}	10	—	ms
EEPROM Programming Voltage Discharge Period	t_{EEFPV}	100	—	μ s
Number of Programming Operations to the Same EEPROM Byte Before Erase ⁽¹⁾	—	—	8	—
EEPROM Write/Erase Cycles @ 10 ms Write Time	—	10,000	—	Cycles
EEPROM Data Retention After 10,000 Write/Erase Cycles	—	10	—	Years
EEPROM Programming Maximum Time to 'AUTO' Bit Set	---	---	500	μ s
EEPROM Erasing Maximum Time to 'AUTO' Bit Set	---	---	8	ms

NOTES:

1. Programming a byte more times than the specified maximum may affect the data integrity of that byte. The byte must be erased before it can be programmed again.

25.2.14 FLASH Memory Characteristics

Characteristic	Symbol	Min	Max	Unit
FLASH Program Bus Clock Frequency	—	1	—	MHz
FLASH Read Bus Clock Frequency	$f_{\text{READ}}^{(1)}$	32K	8.4M	Hz
FLASH Page Erase Time	$t_{\text{ERASE}}^{(2)}$	1	—	ms
FLASH Mass Erase Time	$t_{\text{MERASE}}^{(3)}$	4	—	ms
FLASH PGM/ERASE to HVEN Set Up Time	t_{NVS}	10	—	μs
FLASH High Voltage Hold Time	t_{NVH}	5	—	μs
FLASH High Voltage Hold Time (Mass)	t_{NVHL}	100	—	μs
FLASH Program Hold Time	t_{PGS}	5	—	μs
FLASH Program Time	t_{PROG}	30	40	μs
FLASH Return to Read Time	$t_{\text{RCV}}^{(4)}$	1		μs
FLASH Cumulative Program HV Period	$t_{\text{HV}}^{(5)}$	—	4	ms
FLASH Row Erase Endurance ⁽⁶⁾		10,000	—	cycles
FLASH Row Program Endurance ⁽⁷⁾		10,000	—	cycles
FLASH Data Retention Time ⁽⁸⁾		10	—	years

- f_{READ} is defined as the frequency range for which the FLASH memory can be read.
- If the page erase time is longer than $t_{\text{ERASE}}(\text{MIN})$, there is no erase-disturb, but it reduces the endurance of the FLASH memory.
- If the mass erase time is longer than $t_{\text{MERASE}}(\text{MIN})$, there is no erase-disturb, but it reduces the endurance of the FLASH memory.
- t_{RCV} is defined as the time it needs before the FLASH can be read after turning off the high voltage charge pump by clearing HVEN to logic 0.
- t_{HV} is defined as the cumulative high voltage programming time to the same row before next erase.
 t_{HV} must satisfy this condition: $t_{\text{NVS}} + t_{\text{NVH}} + t_{\text{PGS}} + (t_{\text{PROG}} \times 64) \leq t_{\text{HV}} \text{ max.}$
- The minimum row erase endurance value specifies each row of the FLASH memory is guaranteed to work for at least this many erase cycles.
- The minimum row program endurance value specifies each row of the FLASH memory is guaranteed to work for at least this many program cycles.
- The FLASH is guaranteed to retain data over the entire operating temperature range for at least the minimum time specified.

Electrical Specification

25.2.15 BDLC Transmitter VPW Symbol Timings

Characteristic ^{(1), (2)}	Number	Symbol	Min	Typ	Max	Unit
Passive Logic 0	10	t_{TVP1}	62	64	66	μs
Passive Logic 1	11	t_{TVP2}	126	128	130	μs
Active Logic 0	12	t_{TVA1}	126	128	130	μs
Active Logic 1	13	t_{TVA2}	62	64	66	μs
Start-of-Frame (SOF)	14	t_{TVA3}	198	200	202	μs
End-of-Data (EOD)	15	t_{TVP3}	198	200	202	μs
End-of-Frame (EOF)	16	t_{TV4}	278	280	282	μs
Inter-Frame Separator (IFS)	17	t_{TV6}	298	300	302	μs

1. $f_{BDLC} = 1.048576$ or 1.0 MHz, $V_{DD} = 5.0 \text{ V} \pm 10\%$, $V_{SS} = 0 \text{ V}$

2. See **Figure 25-3**.

25.2.16 BDLC Receiver VPW Symbol Timings

Characteristic ^{(1), (2), (3)}	Number	Symbol	Min	Typ	Max	Unit
Passive Logic 0	10	t_{TRVP1}	34	64	96	μs
Passive Logic 1	11	t_{TRVP2}	96	128	163	μs
Active Logic 0	12	t_{TRVA1}	96	128	163	μs
Active Logic 1	13	t_{TRVA2}	34	64	96	μs
Start-of-Frame (SOF)	14	t_{TRVA3}	163	200	239	μs
End-of-Data (EOD)	15	t_{TRVP3}	163	200	239	μs
End-of-Frame (EOF)	16	t_{TRV4}	239	280	320	μs
Break	18	t_{TRV6}	280	—	—	μs

1. $f_{BDLC} = 1.048576$ or 1.0 MHz, $V_{DD} = 5.0 \text{ V} \pm 10\%$, $V_{SS} = 0 \text{ V}$

2. The receiver symbol timing boundaries are subject to an uncertainty of 1 t_{BDLC} μs due to sampling considerations.

3. See **Figure 25-3**.

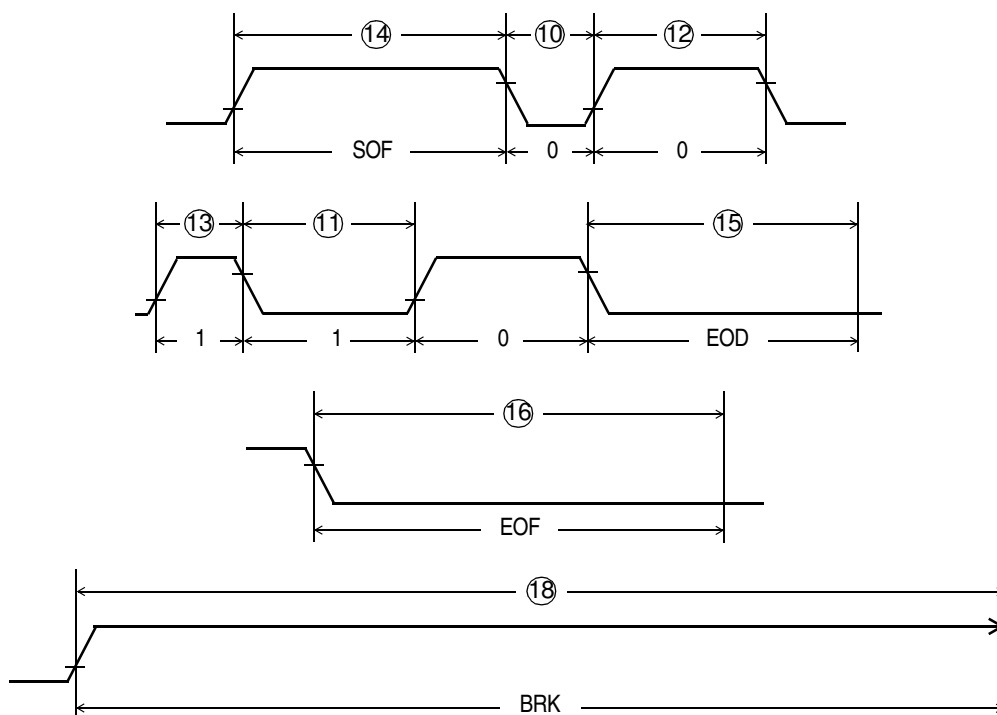

Figure 25-3. BDLC Variable Pulse Width Modulation (VPW) Symbol Timing

25.2.17 BDLC Transmitter DC Electrical Characteristics

Characteristic ⁽¹⁾	Symbol	Min	Max	Unit
BDTxD Output Low Voltage (IBDTxD = 1.6 mA)	V _{OLTX}	—	0.4	V
BDTxD Output High Voltage (IBDTx = -800 μA)	V _{OHTX}	V _{DD} - 0.8	—	V

1. V_{DD} = 5.0 Vdc ± 10%, V_{SS} = 0 Vdc, T_A = -40 °C to +125 °C, unless otherwise noted

25.2.18 BDLC Receiver DC Electrical Characteristics

Characteristic ⁽¹⁾	Symbol	Min	Max	Unit
BDRxD Input Low Voltage	V _{ILRX}	V _{SS}	0.3 × V _{DD}	V
BDRxD Input High Voltage	V _{IHRX}	0.7 × V _{DD}	V _{DD}	V
BDRxD Input Low Current	I _{ILBDRXI}	-1	+1	μA
BDRxD Input High Current	I _{HBDRX}	-1	+1	μA

1. V_{DD} = 5.0 Vdc ± 10%, V_{SS} = 0 Vdc, T_A = -40 °C to +125 °C, unless otherwise noted

25.3 Mechanical Specifications

25.3.1 52-pin Plastic Leaded Chip Carrier (PLCC)

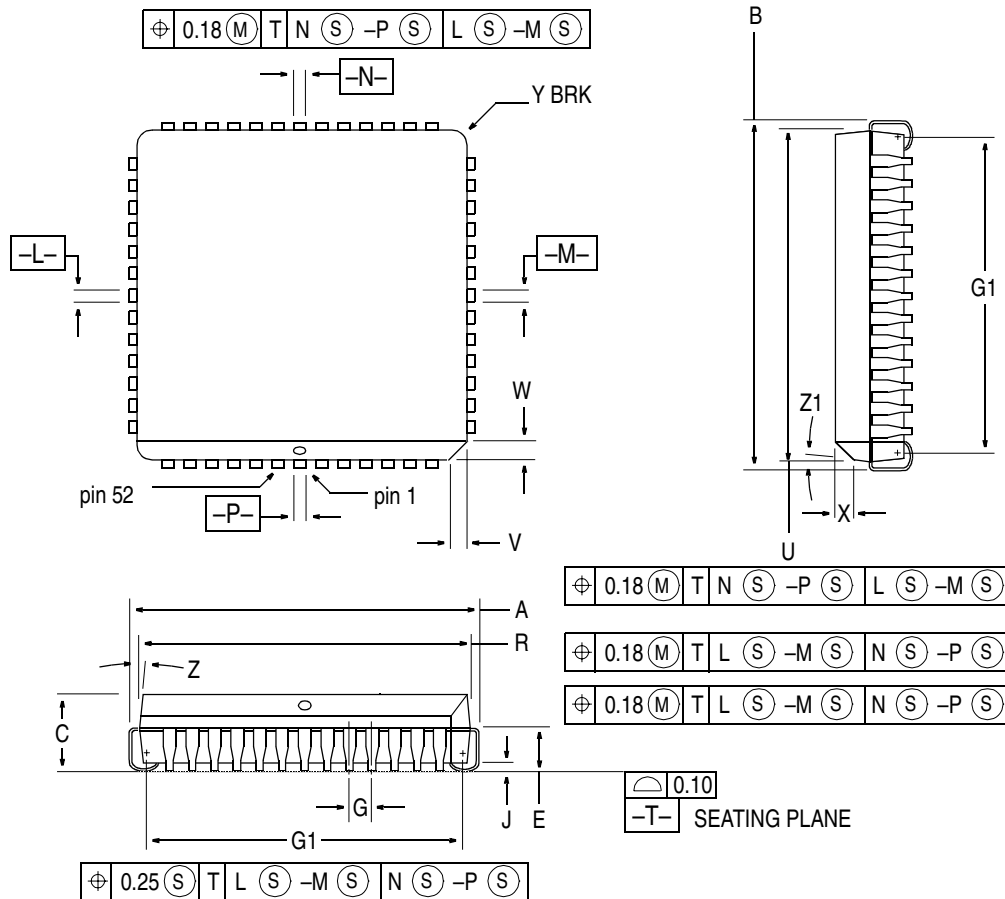

Dim.	Min.	Max.	Notes	Dim.	Min.	Max.
A	19.94	20.19	1. Datums -L-, -M-, -N- and -P- are determined where top of lead shoulder exits plastic body at mould parting line. 2. Dimension G1, true position to be measured at datum -T- (seating plane). 3. Dimensions R and U do not include mould protrusion. Allowable mould protrusion is 0.25mm per side. 4. Dimensions and tolerancing per ANSI Y 14.5M, 1982. 5. All dimensions in mm.	U	19.05	19.20
B	19.94	20.19		V	1.07	1.21
C	4.20	4.57		W	1.07	1.21
E	2.29	2.79		X	1.07	1.42
F	0.33	0.48		Y	—	0.50
G	1.27 BSC			Z	2°	10°
H	0.66	0.81		G1	18.04	18.54
J	0.51	—		K1	1.02	—
K	0.64	—		Z1	2°	10°
R	19.05	19.20				

Glossary

A — See “accumulator (A).”

accumulator (A) — An 8-bit general-purpose register in the CPU08. The CPU08 uses the accumulator to hold operands and results of arithmetic and logic operations.

acquisition mode — A mode of PLL operation during startup before the PLL locks on a frequency. Also see “tracking mode.”

address bus — The set of wires that the CPU or DMA uses to read and write memory locations.

addressing mode — The way that the CPU determines the operand address for an instruction. The M68HC08 CPU has 16 addressing modes.

ALU — See “arithmetic logic unit (ALU).”

arithmetic logic unit (ALU) — The portion of the CPU that contains the logic circuitry to perform arithmetic, logic, and manipulation operations on operands.

asynchronous — Refers to logic circuits and operations that are not synchronized by a common reference signal.

baud rate — The total number of bits transmitted per unit of time.

BCD — See “binary-coded decimal (BCD).”

binary — Relating to the base 2 number system.

binary number system — The base 2 number system, having two digits, 0 and 1. Binary arithmetic is convenient in digital circuit design because digital circuits have two permissible voltage levels, low and high. The binary digits 0 and 1 can be interpreted to correspond to the two digital voltage levels.

binary-coded decimal (BCD) — A notation that uses 4-bit binary numbers to represent the 10 decimal digits and that retains the same positional structure of a decimal number. For example,

234 (decimal) = 0010 0011 0100 (BCD)

bit — A binary digit. A bit has a value of either logic 0 or logic 1.

branch instruction — An instruction that causes the CPU to continue processing at a memory location other than the next sequential address.

break module — A module in the M68HC08 Family. The break module allows software to halt program execution at a programmable point in order to enter a background routine.

breakpoint — A number written into the break address registers of the break module. When a number appears on the internal address bus that is the same as the number in the break address registers, the CPU executes the software interrupt instruction (SWI).

break interrupt — A software interrupt caused by the appearance on the internal address bus of the same value that is written in the break address registers.

bus — A set of wires that transfers logic signals.

bus clock — The bus clock is derived from the CGMOUT output from the CGM. The bus clock frequency, f_{op} , is equal to the frequency of the oscillator output, CGMXCLK, divided by four.

byte — A set of eight bits.

C — The carry/borrow bit in the condition code register. The CPU08 sets the carry/borrow bit when an addition operation produces a carry out of bit 7 of the accumulator or when a subtraction operation requires a borrow. Some logical operations and data manipulation instructions also clear or set the carry/borrow bit (as in bit test and branch instructions and shifts and rotates).

CCR — See “condition code register.”

central processor unit (CPU) — The primary functioning unit of any computer system. The CPU controls the execution of instructions.

CGM — See “clock generator module (CGM).”

- clear** — To change a bit from logic 1 to logic 0; the opposite of set.
- clock** — A square wave signal used to synchronize events in a computer.
- clock generator module (CGM)** — A module in the M68HC08 Family. The CGM generates a base clock signal from which the system clocks are derived. The CGM may include a crystal oscillator circuit and or phase-locked loop (PLL) circuit.
- comparator** — A device that compares the magnitude of two inputs. A digital comparator defines the equality or relative differences between two binary numbers.
- computer operating properly module (COP)** — A counter module in the M68HC08 Family that resets the MCU if allowed to overflow.
- condition code register (CCR)** — An 8-bit register in the CPU08 that contains the interrupt mask bit and five bits that indicate the results of the instruction just executed.
- control bit** — One bit of a register manipulated by software to control the operation of the module.
- control unit** — One of two major units of the CPU. The control unit contains logic functions that synchronize the machine and direct various operations. The control unit decodes instructions and generates the internal control signals that perform the requested operations. The outputs of the control unit drive the execution unit, which contains the arithmetic logic unit (ALU), CPU registers, and bus interface.
- COP** — See "computer operating properly module (COP)."
- counter clock** — The input clock to the TIM counter. This clock is the output of the TIM prescaler.
- CPU** — See "central processor unit (CPU)."
- CPU08** — The central processor unit of the M68HC08 Family.
- CPU clock** — The CPU clock is derived from the CGMOUT output from the CGM. The CPU clock frequency is equal to the frequency of the oscillator output, CGMXCLK, divided by four.
- CPU cycles** — A CPU cycle is one period of the internal bus clock, normally derived by dividing a crystal oscillator source by two or more so the high and low times will be equal. The length of time required to execute an instruction is measured in CPU clock cycles.

CPU registers — Memory locations that are wired directly into the CPU logic instead of being part of the addressable memory map. The CPU always has direct access to the information in these registers. The CPU registers in an M68HC08 are:

- A (8-bit accumulator)
- H:X (16-bit index register)
- SP (16-bit stack pointer)
- PC (16-bit program counter)
- CCR (condition code register containing the V, H, I, N, Z, and C bits)

CSIC — customer-specified integrated circuit

cycle time — The period of the operating frequency: $t_{CYC} = 1/f_{OP}$.

decimal number system — Base 10 numbering system that uses the digits zero through nine.

direct memory access module (DMA) — A M68HC08 Family module that can perform data transfers between any two CPU-addressable locations without CPU intervention. For transmitting or receiving blocks of data to or from peripherals, DMA transfers are faster and more code-efficient than CPU interrupts.

DMA — See "direct memory access module (DMA)."

DMA service request — A signal from a peripheral to the DMA module that enables the DMA module to transfer data.

duty cycle — A ratio of the amount of time the signal is on versus the time it is off. Duty cycle is usually represented by a percentage.

EEPROM — Electrically erasable, programmable, read-only memory. A nonvolatile type of memory that can be electrically reprogrammed.

EPROM — Erasable, programmable, read-only memory. A nonvolatile type of memory that can be erased by exposure to an ultraviolet light source and then reprogrammed.

exception — An event such as an interrupt or a reset that stops the sequential execution of the instructions in the main program.

external interrupt module (IRQ) — A module in the M68HC08 Family with both dedicated external interrupt pins and port pins that can be enabled as interrupt pins.

- fetch** — To copy data from a memory location into the accumulator.
- firmware** — Instructions and data programmed into nonvolatile memory.
- free-running counter** — A device that counts from zero to a predetermined number, then rolls over to zero and begins counting again.
- full-duplex transmission** — Communication on a channel in which data can be sent and received simultaneously.
- H** — The upper byte of the 16-bit index register (H:X) in the CPU08.
- H** — The half-carry bit in the condition code register of the CPU08. This bit indicates a carry from the low-order four bits of the accumulator value to the high-order four bits. The half-carry bit is required for binary-coded decimal arithmetic operations. The decimal adjust accumulator (DAA) instruction uses the state of the H and C bits to determine the appropriate correction factor.
- hexadecimal** — Base 16 numbering system that uses the digits 0 through 9 and the letters A through F.
- high byte** — The most significant eight bits of a word.
- illegal address** — An address not within the memory map
- illegal opcode** — A nonexistent opcode.
- I** — The interrupt mask bit in the condition code register of the CPU08. When I is set, all interrupts are disabled.
- index register (H:X)** — A 16-bit register in the CPU08. The upper byte of H:X is called H. The lower byte is called X. In the indexed addressing modes, the CPU uses the contents of H:X to determine the effective address of the operand. H:X can also serve as a temporary data storage location.
- input/output (I/O)** — Input/output interfaces between a computer system and the external world. A CPU reads an input to sense the level of an external signal and writes to an output to change the level on an external signal.
- instructions** — Operations that a CPU can perform. Instructions are expressed by programmers as assembly language mnemonics. A CPU interprets an opcode and its associated operand(s) and instruction.

interrupt — A temporary break in the sequential execution of a program to respond to signals from peripheral devices by executing a subroutine.

interrupt request — A signal from a peripheral to the CPU intended to cause the CPU to execute a subroutine.

I/O — See “input/output (I/O).”

IRQ — See “external interrupt module (IRQ).”

jitter — Short-term signal instability.

latch — A circuit that retains the voltage level (logic 1 or logic 0) written to it for as long as power is applied to the circuit.

latency — The time lag between instruction completion and data movement.

least significant bit (LSB) — The rightmost digit of a binary number.

logic 1 — A voltage level approximately equal to the input power voltage (V_{DD}).

logic 0 — A voltage level approximately equal to the ground voltage (V_{SS}).

low byte — The least significant eight bits of a word.

low voltage inhibit module (LVI) — A module in the M68HC08 Family that monitors power supply voltage.

LVI — See “low voltage inhibit module (LVI).”

M68HC08 — A Motorola family of 8-bit MCUs.

mark/space — The logic 1/logic 0 convention used in formatting data in serial communication.

mask — 1. A logic circuit that forces a bit or group of bits to a desired state. 2. A photomask used in integrated circuit fabrication to transfer an image onto silicon.

mask option — A optional microcontroller feature that the customer chooses to enable or disable.

mask option register (MOR) — An EPROM location containing bits that enable or disable certain MCU features.

MCU — Microcontroller unit. See “microcontroller.”

memory location — Each M68HC08 memory location holds one byte of data and has a unique address. To store information in a memory location, the CPU places the address of the location on the address bus, the data information on the data bus, and asserts the write signal. To read information from a memory location, the CPU places the address of the location on the address bus and asserts the read signal. In response to the read signal, the selected memory location places its data onto the data bus.

memory map — A pictorial representation of all memory locations in a computer system.

microcontroller — Microcontroller unit (MCU). A complete computer system, including a CPU, memory, a clock oscillator, and input/output (I/O) on a single integrated circuit.

modulo counter — A counter that can be programmed to count to any number from zero to its maximum possible modulus.

monitor ROM — A section of ROM that can execute commands from a host computer for testing purposes.

MOR — See "mask option register (MOR)."

most significant bit (MSB) — The leftmost digit of a binary number.

multiplexer — A device that can select one of a number of inputs and pass the logic level of that input on to the output.

N — The negative bit in the condition code register of the CPU08. The CPU sets the negative bit when an arithmetic operation, logical operation, or data manipulation produces a negative result.

nibble — A set of four bits (half of a byte).

object code — The output from an assembler or compiler that is itself executable machine code, or is suitable for processing to produce executable machine code.

opcode — A binary code that instructs the CPU to perform an operation.

open-drain — An output that has no pullup transistor. An external pullup device can be connected to the power supply to provide the logic 1 output voltage.

operand — Data on which an operation is performed. Usually a statement consists of an operator and an operand. For example, the operator may be an add instruction, and the operand may be the quantity to be added.

Glossary

oscillator — A circuit that produces a constant frequency square wave that is used by the computer as a timing and sequencing reference.

OTPROM — One-time programmable read-only memory. A nonvolatile type of memory that cannot be reprogrammed.

overflow — A quantity that is too large to be contained in one byte or one word.

page zero — The first 256 bytes of memory (addresses \$0000–\$00FF).

parity — An error-checking scheme that counts the number of logic 1s in each byte transmitted. In a system that uses odd parity, every byte is expected to have an odd number of logic 1s. In an even parity system, every byte should have an even number of logic 1s. In the transmitter, a parity generator appends an extra bit to each byte to make the number of logic 1s odd for odd parity or even for even parity. A parity checker in the receiver counts the number of logic 1s in each byte. The parity checker generates an error signal if it finds a byte with an incorrect number of logic 1s.

PC — See “program counter (PC).”

peripheral — A circuit not under direct CPU control.

phase-locked loop (PLL) — A oscillator circuit in which the frequency of the oscillator is synchronized to a reference signal.

PLL — See "phase-locked loop (PLL)."

pointer — Pointer register. An index register is sometimes called a pointer register because its contents are used in the calculation of the address of an operand, and therefore points to the operand.

polarity — The two opposite logic levels, logic 1 and logic 0, which correspond to two different voltage levels, V_{DD} and V_{SS} .

polling — Periodically reading a status bit to monitor the condition of a peripheral device.

port — A set of wires for communicating with off-chip devices.

prescaler — A circuit that generates an output signal related to the input signal by a fractional scale factor such as 1/2, 1/8, 1/10 etc.

program — A set of computer instructions that cause a computer to perform a desired operation or operations.

program counter (PC) — A 16-bit register in the CPU08. The PC register holds the address of the next instruction or operand that the CPU will use.

- pull** — An instruction that copies into the accumulator the contents of a stack RAM location. The stack RAM address is in the stack pointer.
- pullup** — A transistor in the output of a logic gate that connects the output to the logic 1 voltage of the power supply.
- pulse-width** — The amount of time a signal is on as opposed to being in its off state.
- pulse-width modulation (PWM)** — Controlled variation (modulation) of the pulse width of a signal with a constant frequency.
- push** — An instruction that copies the contents of the accumulator to the stack RAM. The stack RAM address is in the stack pointer.
- PWM period** — The time required for one complete cycle of a PWM waveform.
- RAM** — Random access memory. All RAM locations can be read or written by the CPU. The contents of a RAM memory location remain valid until the CPU writes a different value or until power is turned off.
- RC circuit** — A circuit consisting of capacitors and resistors having a defined time constant.
- read** — To copy the contents of a memory location to the accumulator.
- register** — A circuit that stores a group of bits.
- reserved memory location** — A memory location that is used only in special factory test modes. Writing to a reserved location has no effect. Reading a reserved location returns an unpredictable value.
- reset** — To force a device to a known condition.
- ROM** — Read-only memory. A type of memory that can be read but cannot be changed (written). The contents of ROM must be specified before manufacturing the MCU.
- SCI** — See "serial communication interface module (SCI)."
- serial** — Pertaining to sequential transmission over a single line.
- serial communications interface module (SCI)** — A module in the M68HC08 Family that supports asynchronous communication.
- serial peripheral interface module (SPI)** — A module in the M68HC08 Family that supports synchronous communication.
- set** — To change a bit from logic 0 to logic 1; opposite of clear.

shift register — A chain of circuits that can retain the logic levels (logic 1 or logic 0) written to them and that can shift the logic levels to the right or left through adjacent circuits in the chain.

signed — A binary number notation that accommodates both positive and negative numbers. The most significant bit is used to indicate whether the number is positive or negative, normally logic 0 for positive and logic 1 for negative. The other seven bits indicate the magnitude of the number.

software — Instructions and data that control the operation of a microcontroller.

software interrupt (SWI) — An instruction that causes an interrupt and its associated vector fetch.

SPI — See "serial peripheral interface module (SPI)."

stack — A portion of RAM reserved for storage of CPU register contents and subroutine return addresses.

stack pointer (SP) — A 16-bit register in the CPU08 containing the address of the next available storage location on the stack.

start bit — A bit that signals the beginning of an asynchronous serial transmission.

status bit — A register bit that indicates the condition of a device.

stop bit — A bit that signals the end of an asynchronous serial transmission.

subroutine — A sequence of instructions to be used more than once in the course of a program. The last instruction in a subroutine is a return from subroutine (RTS) instruction. At each place in the main program where the subroutine instructions are needed, a jump or branch to subroutine (JSR or BSR) instruction is used to call the subroutine. The CPU leaves the flow of the main program to execute the instructions in the subroutine. When the RTS instruction is executed, the CPU returns to the main program where it left off.

synchronous — Refers to logic circuits and operations that are synchronized by a common reference signal.

TIM — See "timer interface module (TIM)."

timer interface module (TIM) — A module used to relate events in a system to a point in time.

timer — A module used to relate events in a system to a point in time.

toggle — To change the state of an output from a logic 0 to a logic 1 or from a logic 1 to a logic 0.

tracking mode — Mode of low-jitter PLL operation during which the PLL is locked on a frequency. Also see "acquisition mode."

two's complement — A means of performing binary subtraction using addition techniques. The most significant bit of a two's complement number indicates the sign of the number (1 indicates negative). The two's complement negative of a number is obtained by inverting each bit in the number and then adding 1 to the result.

unbuffered — Utilizes only one register for data; new data overwrites current data.

unimplemented memory location — A memory location that is not used. Writing to an unimplemented location has no effect. Reading an unimplemented location returns an unpredictable value. Executing an opcode at an unimplemented location causes an illegal address reset.

V — The overflow bit in the condition code register of the CPU08. The CPU08 sets the V bit when a two's complement overflow occurs. The signed branch instructions BGT, BGE, BLE, and BLT use the overflow bit.

variable — A value that changes during the course of program execution.

VCO — See "voltage-controlled oscillator."

vector — A memory location that contains the address of the beginning of a subroutine written to service an interrupt or reset.

voltage-controlled oscillator (VCO) — A circuit that produces an oscillating output signal of a frequency that is controlled by a dc voltage applied to a control input.

waveform — A graphical representation in which the amplitude of a wave is plotted against time.

wired-OR — Connection of circuit outputs so that if any output is high, the connection point is high.

word — A set of two bytes (16 bits).

write — The transfer of a byte of data from the CPU to a memory location.

X — The lower byte of the index register (H:X) in the CPU08.

Z — The zero bit in the condition code register of the CPU08. The CPU08 sets the zero bit when an arithmetic operation, logical operation, or data manipulation produces a result of \$00.

HOW TO REACH US:**USA/EUROPE/LOCATIONS NOT LISTED:**

Motorola Literature Distribution;
P.O. Box 5405, Denver, Colorado 80217
1-303-675-2140 or 1-800-441-2447

JAPAN:

Motorola Japan Ltd.; SPS, Technical Information Center,
3-20-1, Minami-Azabu Minato-ku, Tokyo 106-8573 Japan
81-3-3440-3569

ASIA/PACIFIC:

Motorola Semiconductors H.K. Ltd.;
Silicon Harbour Centre, 2 Dai King Street,
Tai Po Industrial Estate, Tai Po, N.T., Hong Kong
852-26668334

TECHNICAL INFORMATION CENTER:

1-800-521-6274

HOME PAGE:

<http://www.motorola.com/semiconductors>

Information in this document is provided solely to enable system and software implementers to use Motorola products. There are no express or implied copyright licenses granted hereunder to design or fabricate any integrated circuits or integrated circuits based on the information in this document.

Motorola reserves the right to make changes without further notice to any products herein. Motorola makes no warranty, representation or guarantee regarding the suitability of its products for any particular purpose, nor does Motorola assume any liability arising out of the application or use of any product or circuit, and specifically disclaims any and all liability, including without limitation consequential or incidental damages. "Typical" parameters which may be provided in Motorola data sheets and/or specifications can and do vary in different applications and actual performance may vary over time. All operating parameters, including "Typicals" must be validated for each customer application by customer's technical experts. Motorola does not convey any license under its patent rights nor the rights of others. Motorola products are not designed, intended, or authorized for use as components in systems intended for surgical implant into the body, or other applications intended to support or sustain life, or for any other application in which the failure of the Motorola product could create a situation where personal injury or death may occur. Should Buyer purchase or use Motorola products for any such unintended or unauthorized application, Buyer shall indemnify and hold Motorola and its officers, employees, subsidiaries, affiliates, and distributors harmless against all claims, costs, damages, and expenses, and reasonable attorney fees arising out of, directly or indirectly, any claim of personal injury or death associated with such unintended or unauthorized use, even if such claim alleges that Motorola was negligent regarding the design or manufacture of the part.



Motorola and the Stylized M Logo are registered in the U.S. Patent and Trademark Office. digital dna is a trademark of Motorola, Inc. All other product or service names are the property of their respective owners. Motorola, Inc. is an Equal Opportunity/Affirmative Action Employer.

© Motorola, Inc. 2002

MC68HC908AS32A/D

[Motorola](#) > [Semiconductors](#) >

68HC908AS32A : 8-Bit Microcontroller

[SUBSCRIBE FOR UPDATES](#)

The MC68HC908AS32A is a member of the low-cost, high-performance M68HC08 Family of 8-bit microcontroller units (MCUs). The M68HC08 Family is based on the customer-specified integrated circuit (CSIC) design strategy. All MCUs in the family use the enhanced M68HC08 central processor unit (CPU08) and are available with a variety of modules, memory

[Block Diagram](#)

68HC908AS32A Features

- High-performance M68HC08 architecture
- Fully upward-compatible object code with M6805, M146805, and M68HC05 Families
- 8.4-MHz internal bus frequency
- 32K bytes of FLASH Memory
- 512 bytes of on-chip electrically erasable programmable read-only memory (EEPROM)
- 1024 bytes of on-chip random-access memory (RAM)
- Serial peripheral interface module (SPI)
- Serial communications interface module (SCI)

[Return to Top](#)

Page Contents:

- [Features](#)
- [Documentation](#)
- [Tools](#)
- [Rich Media](#)
- [Orderable Parts](#) 
- [Related Links](#)

Other Info:

- [FAQs](#)
- [3rd Party Design Help](#)
- [Training](#)
- [3rd Party Tool](#)
- [Vendors](#)

Rate this Page







Care to Comment?

68HC908AS32A Documentation

Documentation

Application Note

ID	Name	Vendor ID	Format	Size K	Rev #	Date Last Modified	Order Availability
AN1050_D	Designing for Electromagnetic Compatibility (EMC) with HCMOS Microcontrollers	MOTOROLA	pdf	82	0	1/01/2000	-
AN1218/D	HC05 to HC08 Optimization	MOTOROLA	pdf	347	2	1/01/1993	ORDER 
AN1219/D	M68HC08 Integer Math Routines	MOTOROLA	pdf	177	1	1/01/1997	ORDER 
AN1219SW	Software Files for AN1219 zipped	MOTOROLA	zip	77	0	1/01/1995	-
AN1221/D	Hamming Error Control Coding Techniques with the HC08 MCU	MOTOROLA	pdf	63	0	1/01/1993	ORDER 
AN1221SW	Software Files for AN1221 zipped	MOTOROLA	zip	55	0	1/01/1995	-
AN1222/D	Arithmetic Waveform Synthesis with the HC05/08 MCUs	MOTOROLA	pdf	24	0	1/01/1993	ORDER 
AN1222SW	Software Files for AN1222 zipped	MOTOROLA	zip	20	0	1/01/1995	-

AN1259/D	System Design and Layout Techniques for Noise Reduction in MCU-Based Systems	MOTOROLA	pdf	78	0	1/01/1995	ORDER 
AN1263/D	Designing for Electromagnetic Compatibility with Single-Chip Microcontrollers	MOTOROLA	pdf	104	0	1/01/1995	ORDER 
AN1516/D	Liquid Level Control Using a Motorola Pressure Sensor	MOTOROLA	pdf	77	2	1/24/2003	ORDER 
AN1705/D	Noise Reduction Techniques for Microcontroller-Based Systems	MOTOROLA	pdf	67	0	1/01/1999	ORDER 
AN1744/D	Resetting Microcontrollers During Power Transitions	MOTOROLA	pdf	80	0	1/01/1998	ORDER 
AN1752/D	Data Structures for 8-Bit Microcontrollers	MOTOROLA	pdf	213	1	5/07/2001	ORDER 
AN1771/D	Precision Sine-Wave Tone Synthesis Using 8-Bit MCUs	MOTOROLA	pdf	250	0	1/01/1998	ORDER 
AN1775/D	Expanding Digital Input with an A/D Converter	MOTOROLA	pdf	86	1	1/01/1998	ORDER 
AN1783/D	Determining MCU Oscillator Start-Up Parameters	MOTOROLA	pdf	48	1	1/01/1999	ORDER 
AN1818/D	Software SCI Routines with the 16-Bit Timer Module	MOTOROLA	pdf	84	0	1/01/1999	ORDER 
AN1820/D	Software I2C Communications	MOTOROLA	pdf	55	0	1/01/1999	ORDER 
AN1820SW	Software files for AN1820 zipped	MOTOROLA	zip	2	0	1/01/1998	-
AN1837/D	Non-Volatile Memory Technology Overview	MOTOROLA	pdf	116	0	3/27/2000	ORDER 
AN1853/D	Embedding Microcontrollers in Domestic Refrigeration Appliances	MOTOROLA	pdf	221	0	6/22/2000	ORDER 
AN2093/D	Creating Efficient C Code for the MC68HC08	MOTOROLA	pdf	36	0	1/01/2000	ORDER 
AN2103/D	Local Interconnect Network (LIN) Demonstration	MOTOROLA	pdf	953	0	12/01/2000	ORDER 
AN2120/D	Connecting an M68HC08 Family Microcontroller to an Internet Service Provider (ISP) Using the Point-to-Point Protocol (PPP)	MOTOROLA	pdf	741	0	5/20/2001	ORDER 
AN2120SW	Software for AN2120, zip format	MOTOROLA	zip	31	1.0	7/31/2002	-
AN2149/D	Compressor Induction Motor Stall and Rotation Detection using Microcontrollers	MOTOROLA	pdf	127	0	5/30/2001	ORDER 
AN2159/D	Digital Direct Current Ignition System Using HC08 Microcontrollers	MOTOROLA	pdf	129	0	11/20/2001	ORDER 
AN2159SW	AN2159SW	MOTOROLA	zip	182	1	3/08/2002	-
AN2295	Developer's Serial Bootloader for M68HC08	MOTOROLA	pdf	738	4	10/29/2003	ORDER 
AN2295SW	Software for AN2295	MOTOROLA	zip	725	4.0	10/21/2003	-
AN2321/D	Designing for Board Level Electromagnetic Compatibility	MOTOROLA	pdf	1628	0	8/15/2002	ORDER 
AN2342	Opto Isolation Circuits For In Circuit Debugging of 68HC9(S)12 and 68HC908 Microcontrollers	MOTOROLA	pdf	155	0	9/25/2002	ORDER 
AN2438/D	ADC Definitions and Specifications	MOTOROLA	pdf	297	0	2/21/2003	ORDER 
AN2504	On-Chip FLASH Programming API for CodeWarrior	MOTOROLA	pdf	530	0	10/15/2003	ORDER 
AN2504SW	Software files for application note AN2504	MOTOROLA	zip	59	0	10/21/2003	-

AN2571	Converting Demos in Standard Software Drivers for HC908 MOTOROLA Derivatives	MOTOROLA	pdf	430	1	9/11/2003	ORDER
AN4006/D	Digital Captive Discharge Ignition System Using HC05/HC08 8-Bit Microcontrollers	MOTOROLA	pdf	61	0	3/27/2000	ORDER

Brochure

ID	Name	Vendor ID	Format	Size K	Rev #	Date Last Modified	Order Availability
BR68HC08FAMAM/D	68HC08 Family: High Performance and Flexibility	MOTOROLA	pdf	57	2	5/21/2003	ORDER
FLYREMBEDFLASH/D	Embedded Flash: Changing the Technology World for the Better	MOTOROLA	pdf	68	2	5/21/2003	ORDER

Data Sheets

ID	Name	Vendor ID	Format	Size K	Rev #	Date Last Modified	Order Availability
MC68HC908AS32A/D	MC68HC908AS32A Technical Data	MOTOROLA	pdf	2759	0	5/29/2002	ORDER

Engineering Bulletin

ID	Name	Vendor ID	Format	Size K	Rev #	Date Last Modified	Order Availability
EB389/D	TOF Consideration when Measuring a Long Input Capture Event	MOTOROLA	pdf	55	1	4/15/2002	ORDER
EB390/D	Porting the AN2120/D UDP/IP Code to the Avnet Evaluation Board	MOTOROLA	pdf	1501	0	5/09/2002	ORDER
EB396/D	Use of OSC2/XTAL as a Clock Output on Motorola Microcontrollers	MOTOROLA	pdf	49	0	6/19/2002	ORDER
EB398	Techniques to Protect MCU Applications Against Malfunction Due to Code Run-Away	MOTOROLA	pdf	0	0	8/13/2002	ORDER
EB601/D	Initializing a BDLC-Based SAE J1850 Node on a GM Class 2 or Chrysler PCI Network	MOTOROLA	pdf	74	0	7/20/2000	ORDER
EB608/D	Interrupt Handling Considerations When Modifying EEPROM on HC08 Microcontrollers	MOTOROLA	pdf	96	0	8/14/2002	ORDER

Errata - [Click here for important errata information](#)

ID	Name	Vendor ID	Format	Size K	Rev #	Date Last Modified	Order Availability
MSE908AS32A_2L77D	Mask Set Errata for 68HC908AS32A, Mask 2L77D	MOTOROLA	pdf	0	0	7/03/2003	-

Fact Sheets

ID	Name	Vendor ID	Format	Size K	Rev #	Date Last Modified	Order Availability
CWDEVSTUDFACTHC08	Development Studio	MOTOROLA	pdf	48	2	5/13/2002	-

Reference Manual

ID	Name	Vendor ID	Format	Size K	Rev #	Date Last Modified	Order Availability
ADCRM/AD	Analog-to-Digital Reference Manual	MOTOROLA	pdf	231	0	1/01/1996	ORDER
CPU08RM/AD	CPU08RM Central Processor Unit Reference Manual	MOTOROLA	pdf	2666	3	4/03/2002	ORDER
TIM08RM/AD	TIM08 Timer Interface Module Reference Manual	MOTOROLA	pdf	771	1.0	1/10/1996	ORDER

Selector Guide

ID	Name	Vendor ID	Format	Size K	Rev #	Date Last Modified	Order Availability
SG1002	Analog Selector Guide - Quarter 4, 2003	MOTOROLA	pdf	579	0	10/24/2003	ORDER
SG1006	Microcontrollers Selector Guide - Quarter 4, 2003	MOTOROLA	pdf	826	0	10/24/2003	ORDER
SG1010	Sensors Selector Guide - Quarter 4, 2003	MOTOROLA	pdf	219	0	10/24/2003	ORDER
SG1011	Software and Development Tools Selector Guide - Quarter 4, 2003	MOTOROLA	pdf	287	0	10/24/2003	ORDER
SG2000CR	Application Selector Guide Index and Cross-Reference.	MOTOROLA	pdf	95	3	11/11/2003	ORDER
SG2039	Application Selector Guide - Vacuum Cleaners Vacuum Cleaners	MOTOROLA	pdf	0	0	6/17/2003	ORDER

Users Guide

ID	Name	Vendor ID	Format	Size K	Rev #	Date Last Modified	Order Availability
CDSWHC08QS	CodeWarrior™ Development Studio for 68HC08 Quick Start Guide	MOTOROLA	pdf	2847	2.1	9/20/2002	-

[Return to Top](#)

68HC908AS32A Tools

Hardware Tools

Emulators/Probes/Wigglers

ID	Name	Vendor ID	Format	Size K	Rev #	Order Availability
IC10000	iC1000 PowerEmulator	ISYS	-	-	-	-
IC20000	iC2000 PowerEmulator	ISYS	-	-	-	-
IC40000	iC4000 ActiveEmulator	ISYS	-	-	-	-

Evaluation/Development Boards and Systems

ID	Name	Vendor ID	Format	Size K	Rev #	Order Availability
KITMMDS08ASAZ	Modular Development System (MMDS) Kits	MOTOROLA	-	-	-	BUY
M68EM08AS60 ARCHIVED	Emulation Module	MOTOROLA	-	-	-	-
M68CYCLONE08	MON08 Cyclone	METROWERKS	-	-	-	BUY
M68MULTILINK08	MON08 Multilink	METROWERKS	-	-	-	BUY

Programmers

ID	Name	Vendor ID	Format	Size K	Rev #	Order Availability
POWERLAB	Universal Programmer	SYSGEN	-	-	-	-

Software

Application Software

Code Examples

ID	Name	Vendor ID	Format	Size K	Rev #	Order Availability
HC08DELAWSW	HC08 Software Example: Subroutine that delays for a whole number of milliseconds	MOTOROLA	zip	2	-	-
HC08EXSW	HC08 Software Example: Library containing software examples in assembly for 68HC08	MOTOROLA	zip	14	-	-

Device Drivers

ID	Name	Vendor ID	Format	Size K	Rev #	Order Availability
HC908SGF50NVMSSD	HC908 SGF NVM Standard Software Drivers Program/erase software driver for 0.5um SGF NVM (flash and EEPROM) in HC908	MOTOROLA	zip	1387	3.0.0	-

Operating Systems

ID	Name	Vendor ID	Format	Size K	Rev #	Order Availability
CMX-TINY+	CMX-Tiny+	CMX	-	-	-	-

Software Tools

Assemblers

ID	Name	Vendor ID	Format	Size K	Rev #	Order Availability
ADX-08	ADX-08 Macro Assembler-Linker and IDE	AVOCET	-	-	-	-
AX6808	AX6808 relocatable and absolute macro assembler for HC08 and HCS08	COSMIC	-	-	-	-

Compilers

ID	Name	Vendor ID	Format	Size K	Rev #	Order Availability
CX6808S	CX6808 C Cross Compiler for HC08 and HCS08	COSMIC	-	-	-	-
ICC08	ICC08 V6 STD	IMAGE	-	-	-	-

Debuggers

ID	Name	Vendor ID	Format	Size K	Rev #	Order Availability
ZAP 6808 MON08	ZAP 6808 MON08 Debugger and Flash Programmer ZAP 6808 MON08 debugger uses the 68HC08's on-chip monitor interface to provide a real-time ANSI C and assembly source level debugger including FLASH programming, FLASH security and hardware breakpoint support.	MOTOROLA	-	-	-	-
ZAP 6808 MMDS	ZAP 6808 MMDS Debugger	COSMIC	-	-	-	-
ZAP 6808 SIM	ZAP 6808 Simulator Debugger	COSMIC	-	-	-	-
NOICE08	NoICE08	IMAGE	-	-	-	-

IDE (Integrated Development Environment)

ID	Name	Vendor ID	Format	Size K	Rev #	Order Availability
CDCWSEHC08	CodeWarrior Development Studio™ for HC(S)08 Special Edition	METROWERKS	-	-	-	-
CWHC08PRO	CodeWarrior Development Studio for Motorola HC08 Microcontrollers Professional Edition	METROWERKS	-	-	-	BUY
CWHC08STD	CodeWarrior Development Studio for Motorola HC08 Microcontrollers Standard Edition	METROWERKS	-	-	-	BUY
CX6808LT4	HC08 Development Tool Suite 4K Lite (FREE)	COSMIC	-	-	-	-
IDEA08	IDEA08 integrated development environment for HC08 and HCS08	COSMIC	-	-	-	-
IC-SW-OPR	winIDEA	ISYS	-	-	-	-

[Return to Top](#)

Rich Media

Rich Media

Webcast

ID	Name	Vendor ID	Format	Size K	Rev #	Order Availability
RMWC_CODEWARRIOR	CodeWarrior Development Tools for 68HC08 and HCS12 Microcontrollers. Listen to our webcast for an overview of some of the challenges that developers face and an explanation of the CodeWarrior tools that help to address these challenges.	MOTOROLA	html	4	0.0	-
RMWC_QFAMILY	8-bit Microcontroller Overview and Q-Family of Flash Microcontrollers Listen to our companion webcasts to learn about Motorola's recent 8-bit products and services-especially the HC08 Q-Family-that offer maximum design flexibility while helping you get to market fast.	MOTOROLA	htm	5	1.1	-

[Return to Top](#)

Orderable Parts Information

PartNumber	Package Info	Tape and Reel	Life Cycle Description (code)	Budgetary Price QTY 1000+ (\$US)	Additional Info	Order Availability
KMC908AS32ACFN	PLCC 52	No	PRODUCT RAPID GROWTH(2)	-	more	-
KMC908AS32AMFN	PLCC 52	No	PRODUCT RAPID GROWTH(2)	-	more	-
KMC908AS32AVFN	PLCC 52	No	PRODUCT RAPID GROWTH(2)	-	more	-
MC908AS32ACFN	PLCC 52	No	PRODUCT RAPID GROWTH(2)	\$5.95	more	BUY
MC908AS32ACFN R2	PLCC 52	Yes	PRODUCT RAPID GROWTH(2)	-	more	-
MC908AS32AMFN	PLCC 52	No	PRODUCT RAPID GROWTH(2)	\$6.54	more	BUY

MC908AS32AMFNR2	PLCC 52	Yes	PRODUCT RAPID GROWTH(2)	-	more	-
MC908AS32AVFN	PLCC 52	No	PRODUCT RAPID GROWTH(2)	\$6.25	more	BUY 
MC908AS32AVFNR2	PLCC 52	Yes	PRODUCT RAPID GROWTH(2)	-	more	-

NOTE: Are you looking for an obsolete orderable part? Click [HERE](#) to check our distributors' inventory.

[Return to Top](#)

 **Related Links**

- [▶ Automotive](#)
- [▶ Microcontrollers](#)
- [▶ Motor Control](#)
- [▶ Sensors](#)

[Return to Top](#)