

LOC	DIST	REVISIONS					
GP	00	P	LTN	DESCRIPTION	DATE	DWN	APVD
		C		REV PER ECR-07-006314	21MAY2007	CZ	SY
		D		REV PER ECR-07-030973	24DEC2007	CZ	SY
		D1		ADD DASH NUMBER -5	22APR2009	OL	SY
		D2		REV PER ECR-09-010609	11MAY2009	OL	SY
		D3		ADDED DASH NUMBER -6	22APR2010	AL	SY
		E1		REV PER ECR-10-012886	23JUN2010	AL	SY

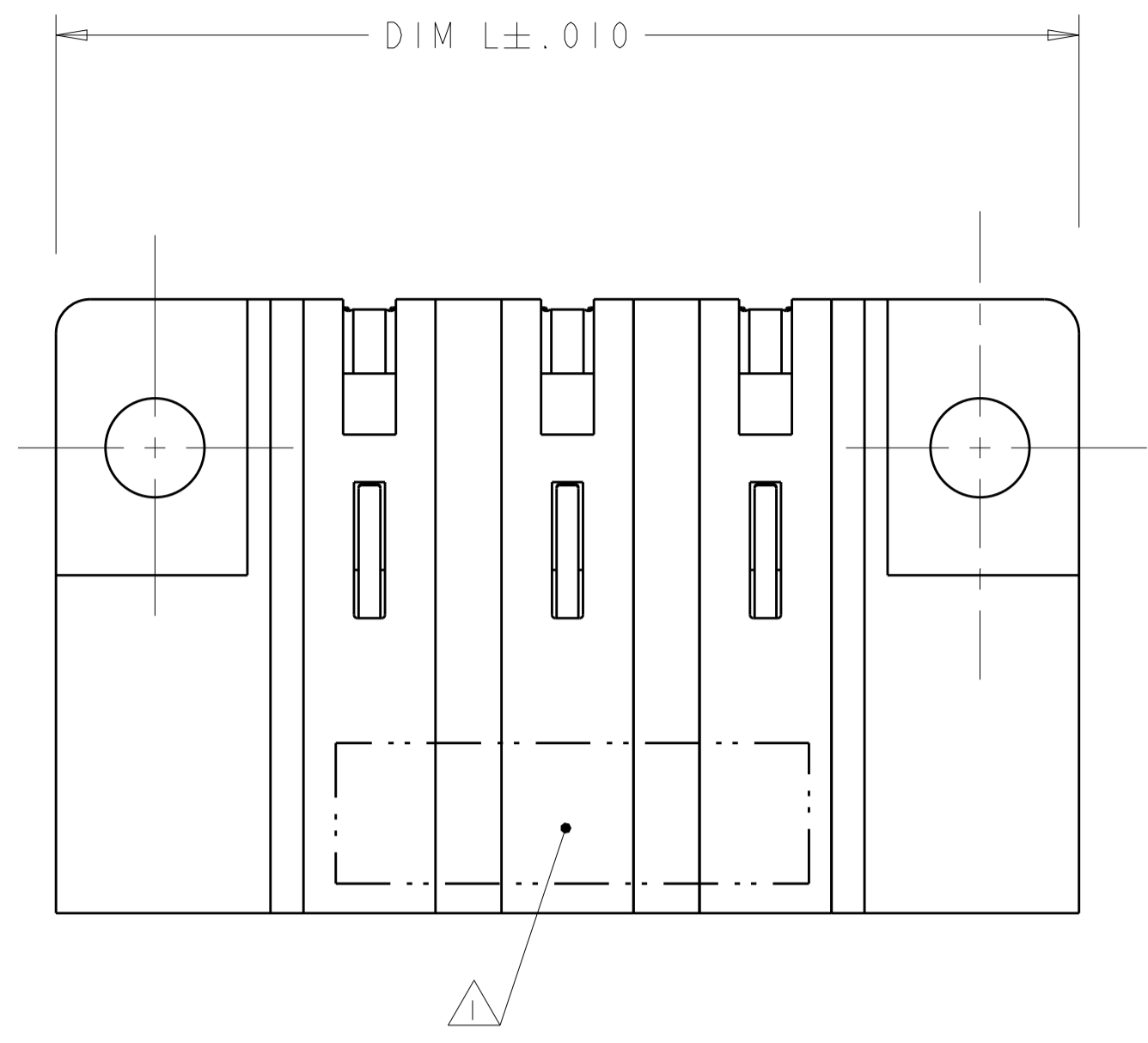

- 1 "AMP" PART NUMBER AND DATE CODE TO BE MARKED IN AREA SHOWN. PARTS UNDER 2.00 LONG MAY BE MARKED ON BOTH SIDES.
- 2 MATERIAL: HOUSING - GLASS FILLED HIGH TEMP THERMO PLASTIC. UL94 V-0  
POWER CONTACT - HIGH CONDUCTIVITY COPPER ALLOY.
- 3 CONTACT PLATING: NOBLE METAL PLATING ON CONTACT FUNCTIONAL AREA OF POWER AND SIGNAL CONTACTS
- 4 MECHANICAL CONNECTOR KEEP OUT ZONE.
- 5 DATUM AND BASIC DIMENSIONS ESTABLISHED BY CUSTOMER.
- 6 PCB- ALL HOLE DIAMETERS ARE FINISHED HOLE SIZES.
- 7 PCB- .0453±.0010 DRILLED HOLES WITH .0003 MIN Sn OVER .001 TO .003 Cu PLATING TO ACHIEVE A .040±.003 DIA. HOLE
- 8 VARIABLE DIMENSIONS SHOWN ON VIEW (SHEET2 AND SHEET3).

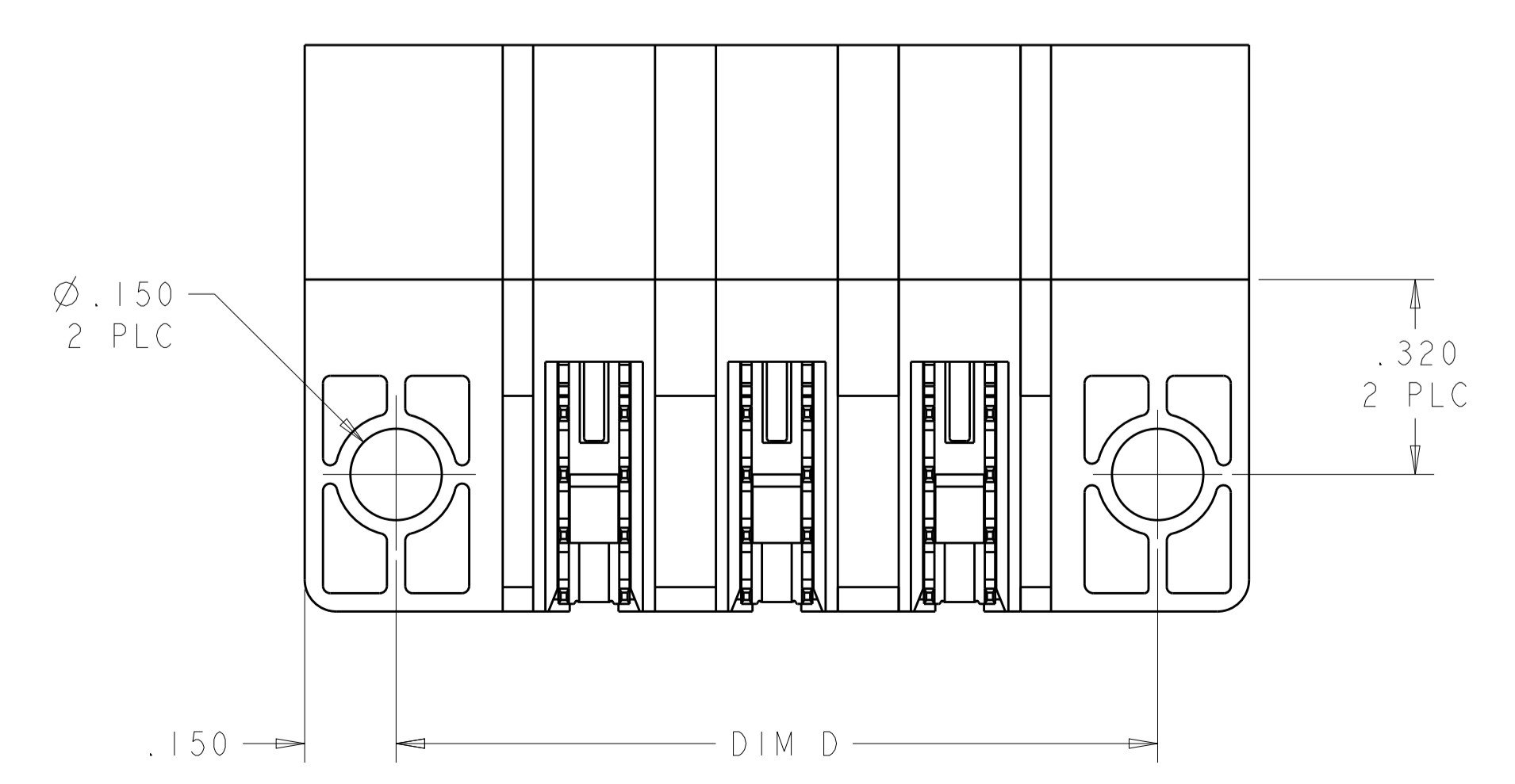
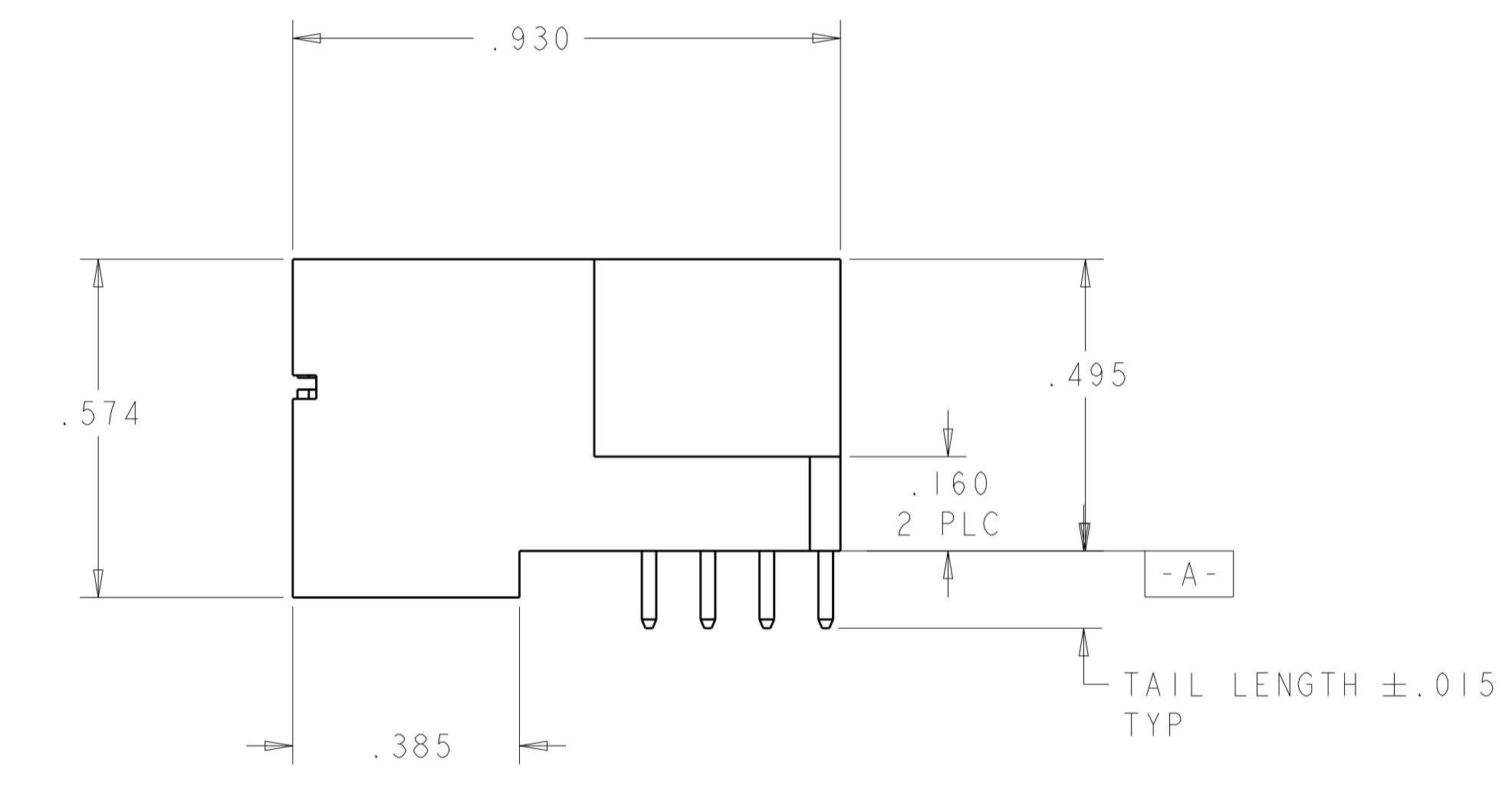
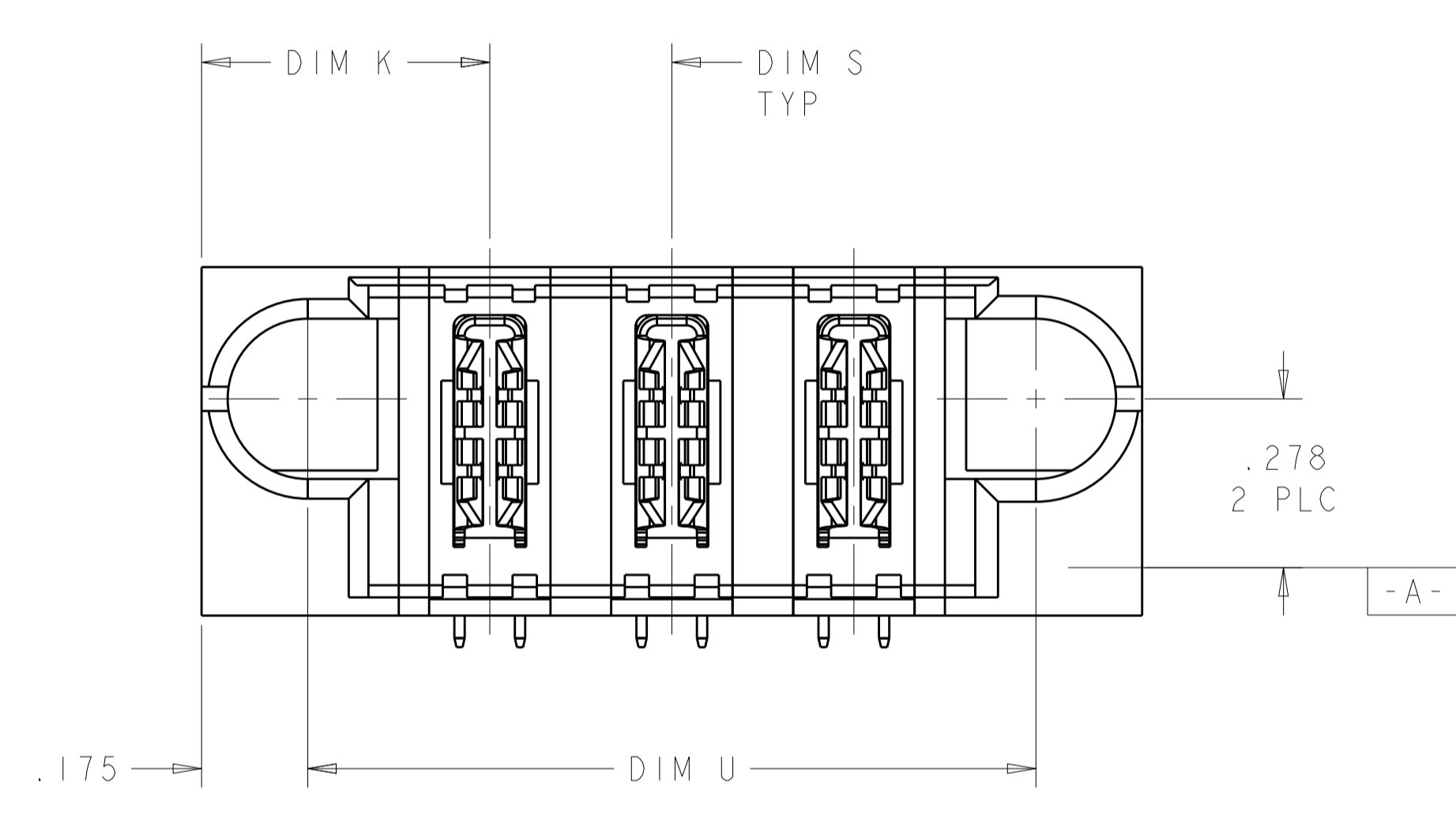

.250	1.800	1.850	2.150	.450	6P	6450323-7
.200	5.550	5.600	5.900	.450	26P	6450323-5
8	2.500	2.550	2.850	.450	9P	6450323-4
8	1.900	1.950	2.250	.525	6P	6450323-3
.300	1.800	1.850	2.150	.475	5ACP	6450323-2
.300	1.200	1.250	1.550	.475	3 ACP	6450323-1
DIM S	DIM U	DIM D	DIM L	DIM K	DESCRIPTION	PART NUMBER

THIS DRAWING IS UNPUBLISHED. RELEASED FOR PUBLICATION BY TYCO ELECTRONICS CORPORATION. ALL RIGHTS RESERVED.

DIMENSIONS: INCHES  
 TOLERANCES UNLESS OTHERWISE SPECIFIED:  
 0 PLC ±.01  
 1 PLC ±.01  
 2 PLC ±.01  
 3 PLC ±.005  
 4 PLC ±.0020  
 ANGLES ±.0020

MATERIAL: 2  
 FINISH: 3

DWN: R. GRZYBOWSKI  
 CHK: M. PERCHERKE  
 APVD: M. PERCHERKE

30MAR05  
 30MAR05

Tyco Electronics  
 Harrisburg, PA 17105-3608

NAME: RIGHT ANGLE HEADER ASSEMBLY W/GUIDES MULTI-BEAM XL

PRODUCT SPEC: 108-1973  
 APPLICATION SPEC: 114-13038

SIZE: A1  
 CAGE CODE: 00779  
 DRAWING NO: 6450323

RESTRICTED TO: -

CUSTOMER DRAWING  
 SCALE: 4:1  
 SHEET: 1 OF 5  
 REV: E1

LOC	DIST	REV	DATE	BY	APPV
GP	00				

  

REVISIONS			
REV	DATE	BY	APPV
-	-	-	-
-	-	-	-

PART NUMBER	ROWS	POWER		
		P1	P2	P3
6450323-1	D C B A	PM	PM	PM
3ACP				

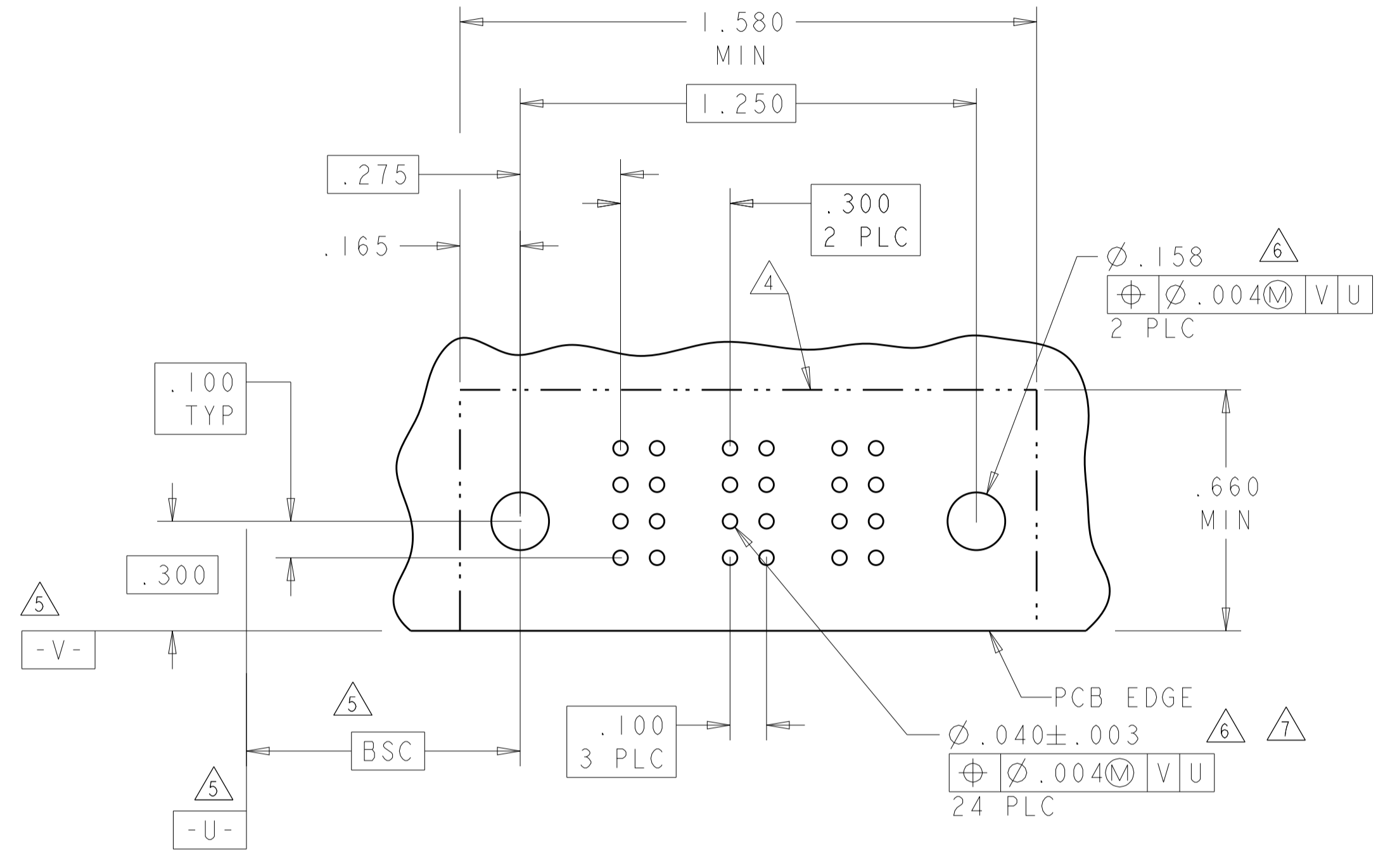

PART NUMBER	ROWS	POWER				
		P1	P2	P3	P4	P5
6450323-2	D C B A	PM	PM	PM	PM	PM
5ACP						

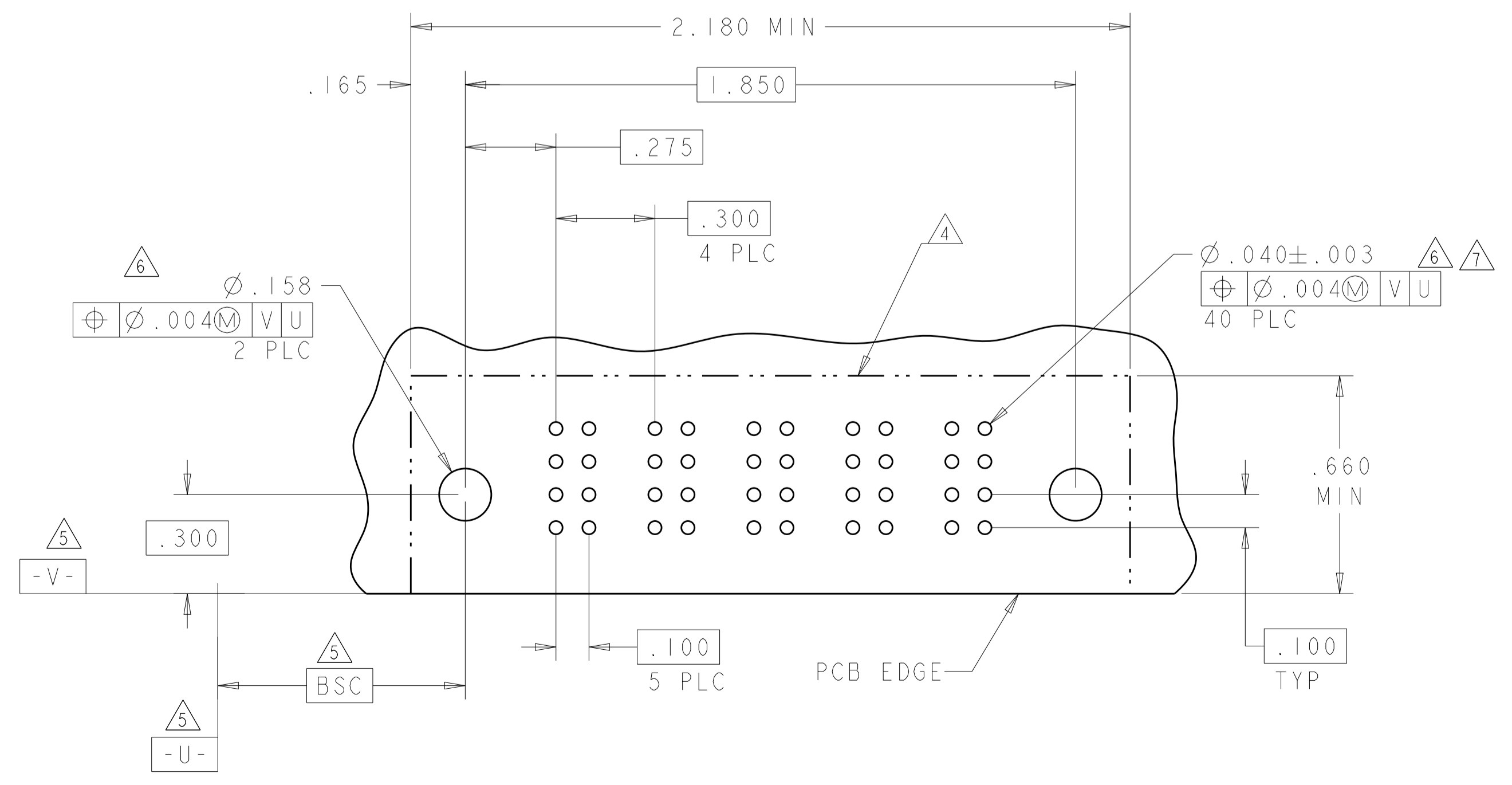

PART NUMBER	ROWS	POWER								
		P1	P2	P3	P4	P5	P6	P7	P8	P9
6450323-4	D C B A	PM	PM	PM	PM	PM	PM	PM	PM	PM
9P										

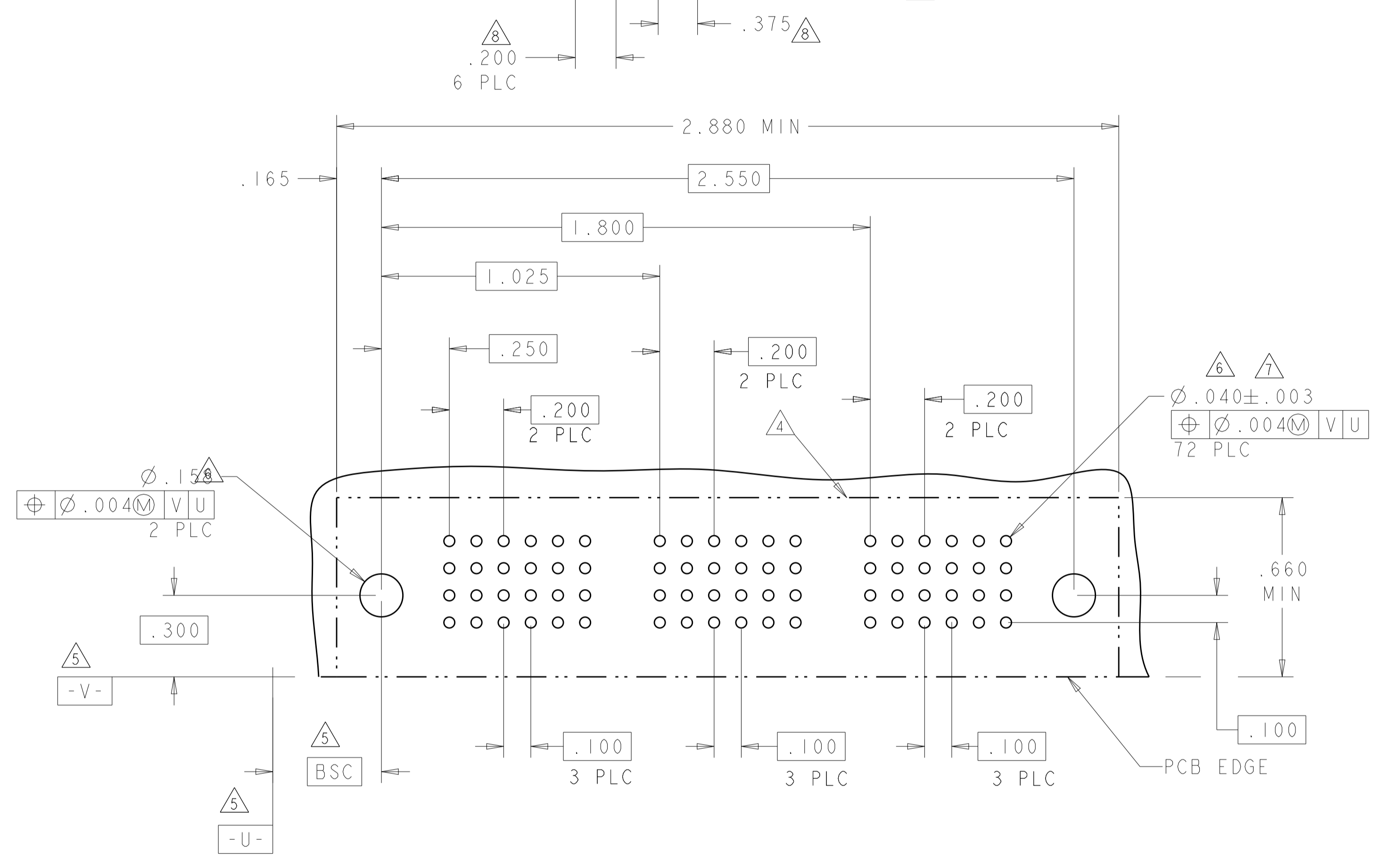

PM	.135
CODE	TAIL LENGTH
POWER CONTACT	

<small>THIS DRAWING IS UNPUBLISHED. RELEASED FOR PUBLICATION. COPYRIGHT 20 BY TYCO ELECTRONICS CORPORATION. ALL RIGHTS RESERVED.</small>		DWN: R. GRZYBOWSKI CHK: M. PERCHERKE APVD: M. PERCHERKE	30MAR05 30MAR05 NAME: M. PERCHERKE PRODUCT SPEC: 108-1973 APPLICATION SPEC: 114-13038 WEIGHT: - FINISH: 3	Tyco Electronics Harrisburg, PA 17105-3608
DIMENSIONS: INCHES TOLERANCES UNLESS OTHERWISE SPECIFIED: 0 PLC ±. 1 PLC ±.01 2 PLC ±.01 3 PLC ±.005 4 PLC ±.0020 ANGLES ±.0°		NAME: RIGHT ANGLE HEADER ASSEMBLY W/GUIDES MULTI-BEAM XL SIZE: A1 CAGE CODE: 00779 DRAWING NO: 6450323 CUSTOMER DRAWING		RESTRICTED TO: - SCALE: 4:1 SHEET: 2 OF 5 REV: E1

LOC		DIST		REVISIONS				
GP	00	P	LTH	DESCRIPTION	DATE	DWN	APVD	
-	-	-	-	SEE SHEET 1	-	-	-	

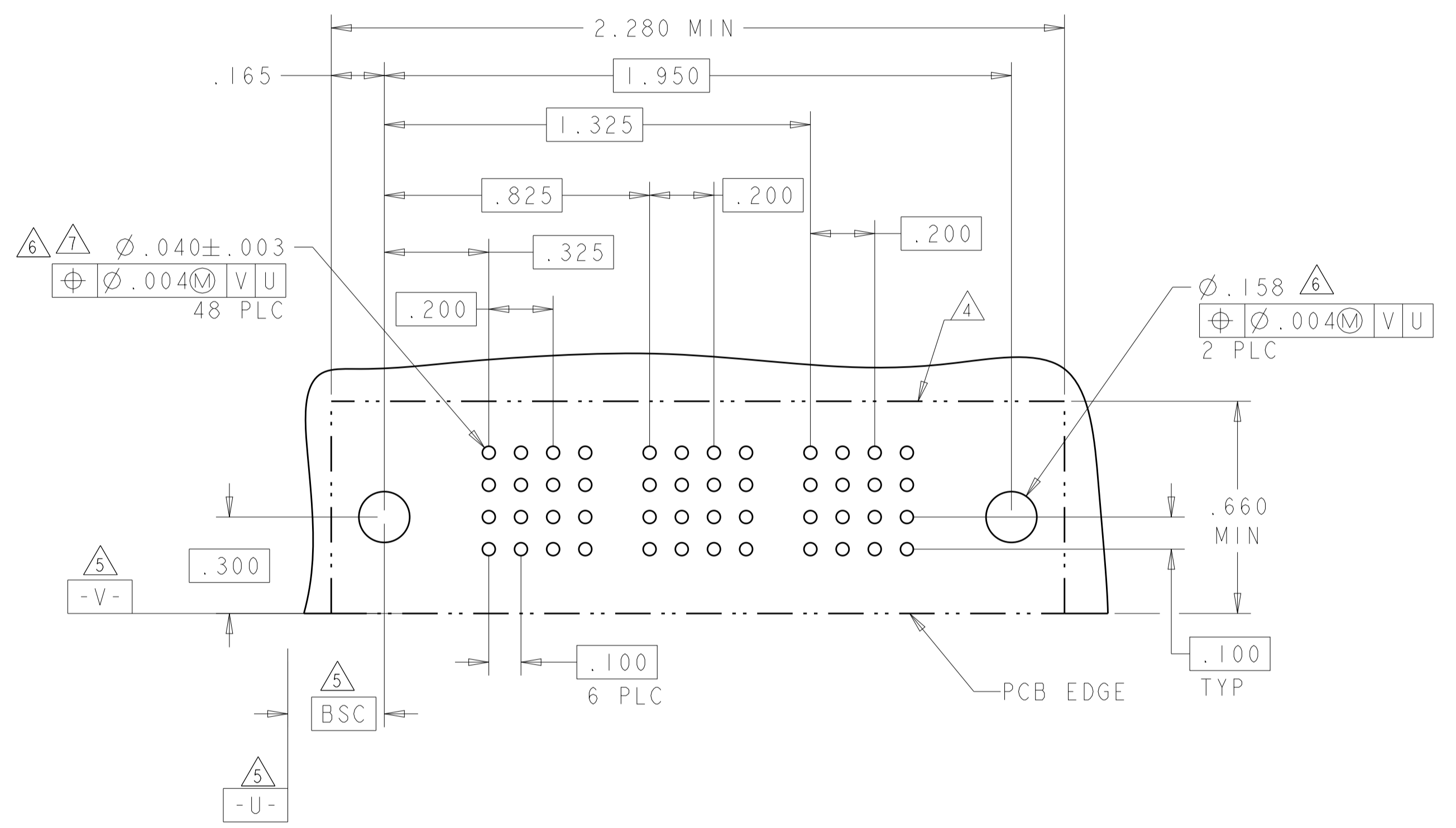
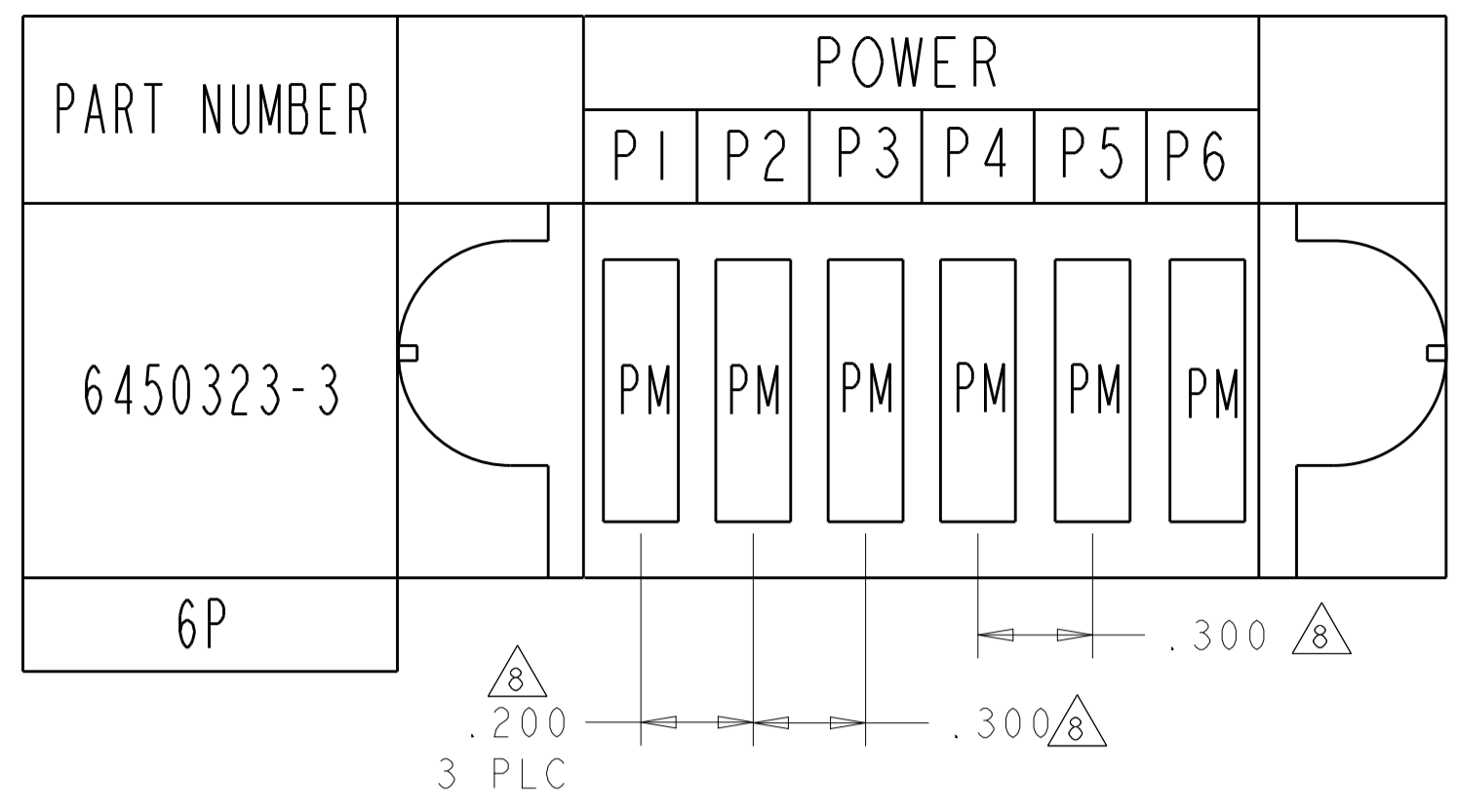

<small>THIS DRAWING IS UNPUBLISHED. RELEASED FOR PUBLICATION BY TYCO ELECTRONICS CORPORATION. ALL RIGHTS RESERVED.</small>		DWN: R. GRZYBOWSKI 30MAR05 CHK: M. PERCHERKE 30MAR05 APVD: M. PERCHERKE		Tyco Electronics Harrisburg, PA 17105-3608	
DIMENSIONS: INCHES		TOLERANCES UNLESS OTHERWISE SPECIFIED: 0 PLC ±. 1 PLC ±.01 2 PLC ±.01 3 PLC ±.005 4 PLC ±.0020 ANGLES ±.2° FINISH 3		NAME: RIGHT ANGLE HEADER ASSEMBLY W/GUIDES MULTI-BEAM XL PRODUCT SPEC: 108-1973 APPLICATION SPEC: 114-13038 WEIGHT: - CUSTOMER DRAWING	
MATERIAL: - FINISH: 3		SIZE: A   00779 CAGE CODE: 6450323 SCALE: 4:1 SHEET: 3 OF 5		RESTRICTED TO: - REV: E   1	

LOC	DIST	REVISIONS					
GP	00	P	LTN	DESCRIPTION	DATE	DMN	APVD
		-		SEE SHEET 1			

PART NUMBER	ROWS	POWER																									
		P1	P2	P3	P4	P5	P6	P7	P8	P9	P10	P11	P12	P13	P14	P15	P16	P17	P18	P19	P20	P21	P22	P23	P24	P25	P26
6450323-5	D C B A	PM	PM		PM		PM		PM		PM	PM		PM		PM		PM		PM	PM		PM		PM		PM
26P																											

NO CONTACTS LOADED

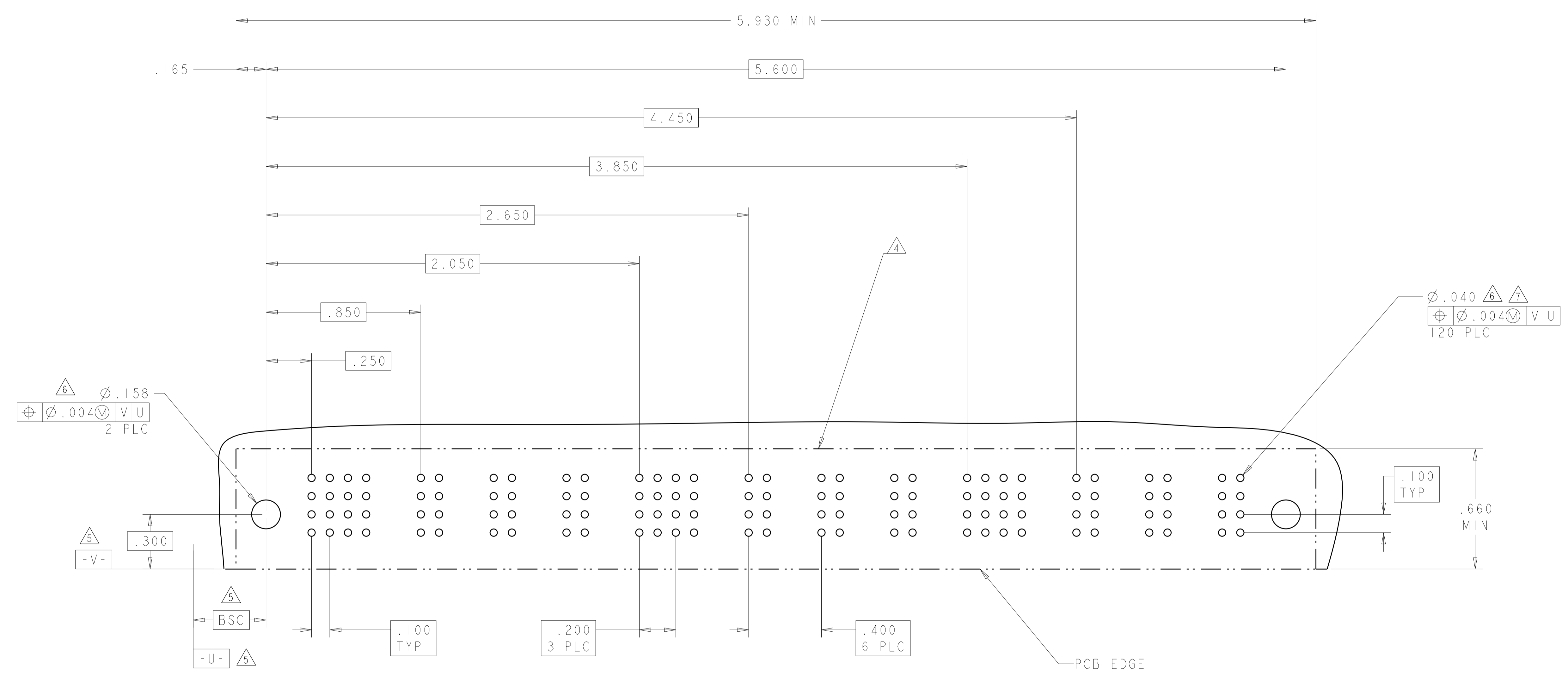

DIMENSIONS: INCHES 		TOLERANCES UNLESS OTHERWISE SPECIFIED: 0 PLC ±. 1 PLC ±.01 2 PLC ±.01 3 PLC ±.005 4 PLC ±.0020 ANGLES ±.2° FINISH 3		DWN R. GRZYBOWSKI 30MAR05 CHK M. PERCHERKE 30MAR05 APVD M. PERCHERKE NAME RIGHT ANGLE HEADER ASSEMBLY W/GUIDES MULTI-BEAM XL PRODUCT SPEC 108-1973 APPLICATION SPEC 114-13038 WEIGHT CUSTOMER DRAWING		Tyco Electronics Harrisburg, PA 17105-3608 SIZE A1 CAGE CODE 00779 DRAWING NO. 6450323 SCALE 4:1 SHEET 4 OF 5 REV E1	
---------------------------	--	--	--	--	--	---	--

LOC	DIST	REVISIONS			
P	LTN	DESCRIPTION	DATE	DMN	APVD
-	-	SEE SHEET 1	-	-	-

PART NUMBER	POWER					
	P1	P2	P3	P4	P5	P6
6450323-7	PM	PM	PM	PM	PM	PM
6P						

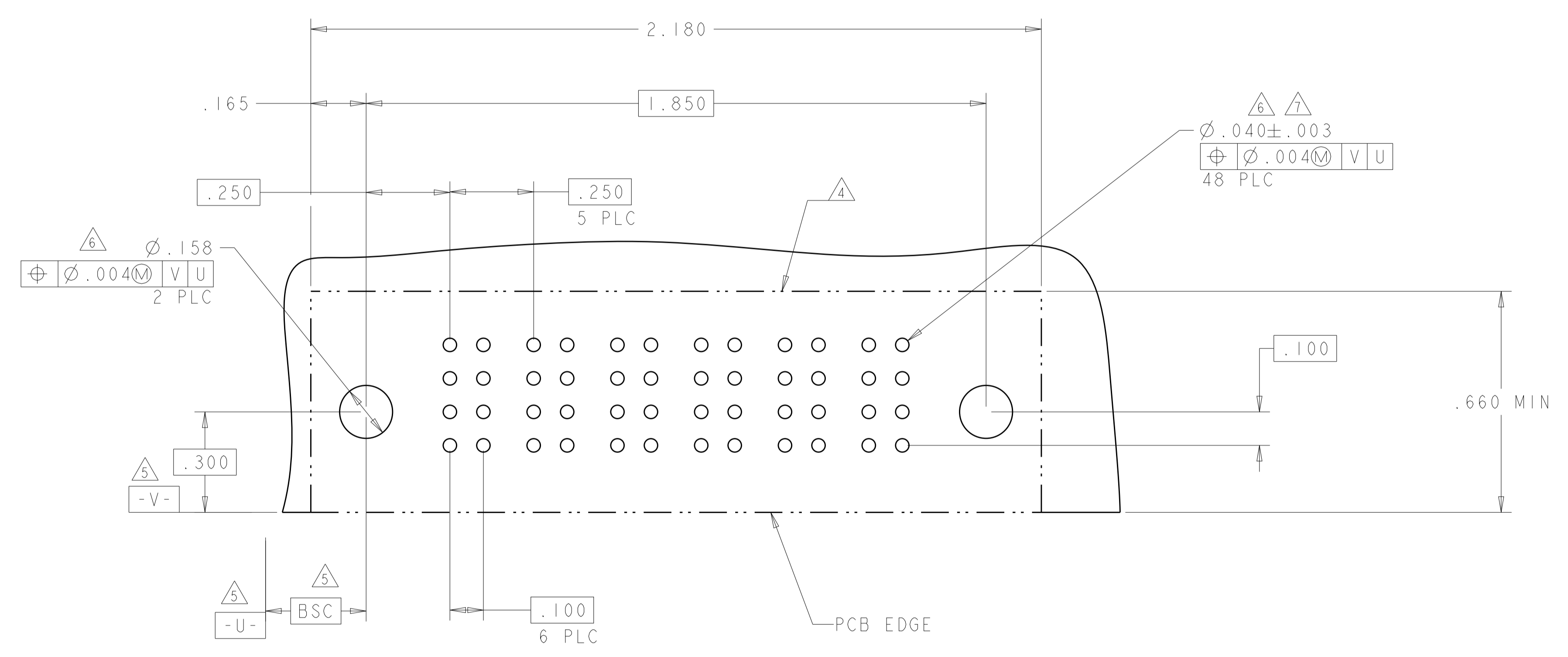

<small>THIS DRAWING IS UNPUBLISHED. RELEASED FOR PUBLICATION. IT IS THE PROPERTY OF TYCO ELECTRONICS CORPORATION. IT IS SUBJECT TO CHANGE WITHOUT NOTICE AND WITHOUT OBLIGATION. SHOULD BE CONTACTED FOR THE LATEST REVISION.</small>		DWN: B. GRZYBOWSKI 30MAR05 CHK: M. PERCHERKE 30MAR05 APVD: M. PERCHERKE	Tyco Electronics Harrisburg, PA 17105-3608
DIMENSIONS: INCHES	TOLERANCES UNLESS OTHERWISE SPECIFIED: 0 PLC ±. 1 PLC ±.01 2 PLC ±.01 3 PLC ±.005 4 PLC ±.0020 ANGLES ±.2°	NAME: RIGHT ANGLE HEADER ASSEMBLY W/GUIDES MULTI-BEAM XL PRODUCT SPEC: 108-1973 APPLICATION SPEC: 114-13038	SIZE: A CAGE CODE: 00779 DRAWING NO: 6450323
MATERIAL: -	FINISH: 3	WEIGHT: -	RESTRICTED TO: -
CUSTOMER DRAWING		SCALE: 4:1	SHEET 5 OF 5 REV: E1