

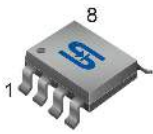

SOP-8



Pin Definition:

- | | |
|----------------------|-----------------------|
| 1. EN/CT | 8. FB |
| 2. GND | 7. OVP |
| 3. V _{GATE} | 6. V _{SENSE} |
| 4. V _{CC} | 5. GATE |

General Description

The TS2581 integrates Pulse-Width-Modulation (PWM) control circuit into a single chip, mainly designs for power-supply regulator. All the functions include an error amplifier, a soft-start, UVLO, OVP, SCP, TSD circuitry.

This device features an internal 100KHz oscillator, the UVLO makes sure that the outputs are off until the internal circuit operates normally.

Features

- Input voltage : 8V to 40V
- Duty ratio : 0% to 100% PWM control
- Oscillation frequency : 100K/300KHz
- Thermal Shutdown function.
- Short Circuit Protect (SCP).
- External SW P-channel MOS.
- External OVP setting function.
- Current mode non-synchronous PWM converter
- External current limit setting.
- Under voltage Lockout.

Ordering Information

Part No.	Package	Packing
TS2581CS RLG	SOP-8	2.5kpcs / 13" Reel

Note: "G" denotes for Halogen Free

Application

- Simple High-efficiency Step down Regulator
- Charger
- Telecommunication

Absolute Maximum Rating

Parameter	Symbol	Limit	Unit
VIN Pin Voltage	V _{IN}	GND - 0.3 to GND + 45	V
VGATE,ISENSE Pin Voltage		GND - 0.3 to V _{IN}	V
Feedback, OVP, EN/CT Pin Voltage		GND - 0.3 to 6	V
Switch Pin Voltage	V _{SW}	GND - 0.3 to V _{IN} + 0.3	V
Power Dissipation	PD	(T _J - T _A) / θ _{JA}	W
Storage Temperature Range	T _{ST}	-40 to +165	°C
Operating Temperature Range	T _{OP}	-20 to +125	°C
Operating Supply Voltage	V _{OP}	+8.5 to +40	V

Thermal Information

Parameter	Symbol	Maximum	Unit
Thermal Resistance (Junction to Case)	θ _{JC}	15	°C/W
Thermal Resistance (Junction to Ambient)	θ _{JA}	40	°C/W

Note1: θ_{JA} is measured on the PCB with minimum copper area.

Note2: θ_{JA} is measured with the PCB copper area (need connect to GROUND pins) of approximately 0.5 in²

Electrical Specifications (Ta = 25°C unless otherwise noted, VIN=12V)

Characteristics	Symbol	Conditions	Min.	Typ.	Max.	Units
Feedback Voltage	V _{FB}	I _{OUT} =10mA	0.98	1	1.02	V
Under Voltage Lockout	U _{VLO}	Falling	-	6	-	V
UVLO Hysteresis	-		-	0.8	-	V
OVP detect voltage	V _{OVP}	Internal define	1.07	1.1	1.13	V
Line Regulation	REG _{LINE}	V _{IN} =10 ~ 40V, I _{OUT} =10mA	-	0.5	1	%
Load Regulation	REG _{LOAD}	I _{OUT} =0~3A, R _{SENSE} = 33mΩ	-	30	50	mV
Quiescent Current	I _{CCQ}	V _{FB} = 1.5V, force driver off.	-	3	6	mA
Oscillator frequency	F _{OSC}	I _{OUT} = 0.5A	70	100	130	KHz
Max. Duty Cycle (ON)	DC	Force driver on V _{FB} = 0.6V	-	100	-	%
Min. Duty Cycle (OFF)		Force driver off V _{FB} = 1.5V	-	0	-	%
Sense Voltage	V _{CC} -V _{SENSE}		-	110	-	mV
EN/CT pin logic input threshold voltage	V _{EN1}	Shutdown mode	-	-	0.4	V
	V _{CT}	Auto restart, V _{FB} <0.4V	0.5	-	1.5	V
Thermal shutdown Temp	T _{SD}		-	160	-	°C
Thermal Shutdown Hysteresis	T _{SH}		-	45	-	°C

Block Diagram

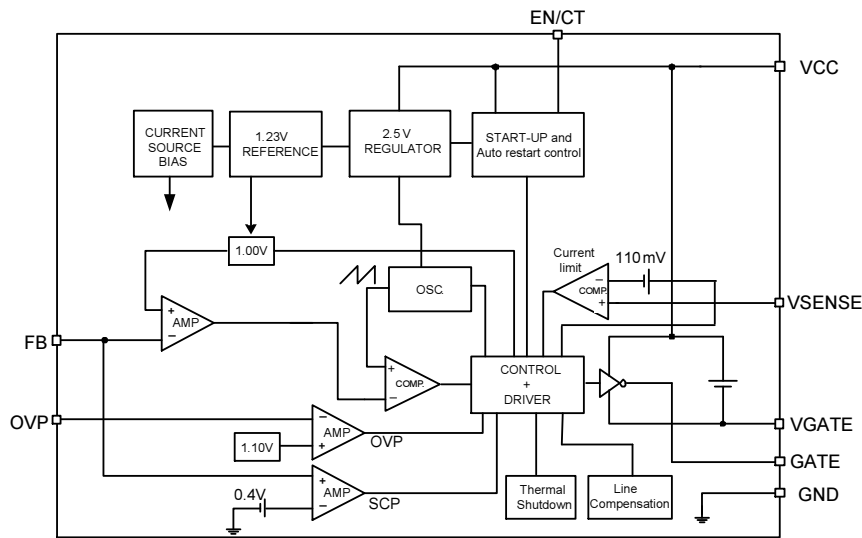

Pin Function Description

Name	Description
EN/CT	Shutdown and auto restart control pin
GND	GND pin
V _{GATE}	Driver gate clamping pin. The pin must connect a 1uF capacitor to VIN
V _{CC}	Operating voltage input
GATE	Switch pin. Connect external inductor and diode here
V _{SENSE}	Voltage Sense input
OVP	Over voltage detect pin
FB	Feedback pin

Function Description

Feedback

Sense the regulated output voltage to complete the feedback loop, when $V_{FB} < 0.4V$, the SCP is happened.

VSENSE

The current limit sense pin, if $V_{IN} - V_{SENSE} \geq 110mV$, the over current is happened that it can turn-off driver cycle by cycle.

OVP

The Over Voltage sense pin, If $VOVP > 1.10V$, the OVP is happened that it can turn-off the driver. You can set V_{OUT} OVP voltage by outside resistances (R3 and R4), Please see below formula to set.

$$V_{OUT (OVP)} = 1.10 \times \left(1 + \frac{R2}{R5}\right)$$

The Over Voltage Protect, If $VOVP > 1.10V$, the OVP is happened that it can turn-off the driver.

Under Voltage Lockout (UVLO)

To avoid error-operation of the device at low input voltages an under voltage lockout is included that disables the device, if the input voltage falls below 6.0V

Thermal Conserdation

The SOP-8L package needs a heat sink under most conditions. The heat sink connect exposed pad of TS2581 to obtain best effect. The size of the heat sink depends on the input voltage, output voltage, output current and ambient temperature.

Typical Application Circuit

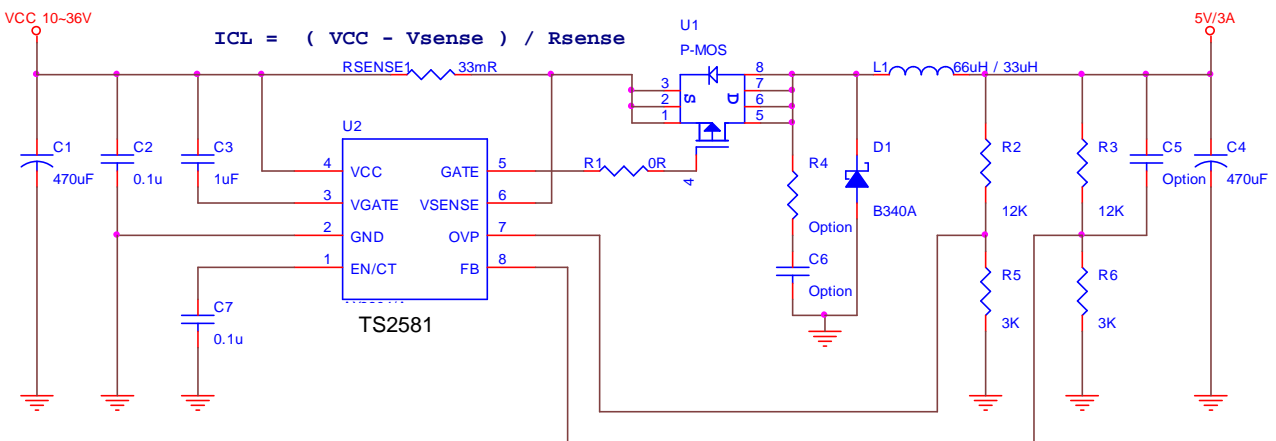



Application Information

Setting the Output Voltage

Application circuit item shows the basic application circuit with adjustable output version. The external resistor sets the output voltage according to the following formula:

$$V_{OUT} = 1.0V \times \left(1 + \frac{R3}{R6}\right)$$

Table 1 Resistor select for output voltage setting

V _{OUT}	R6	R3
5.0V	3K	12K
3.3V	3K6	8K2

Current Limit Protection

The Current limit is set by outside resistance (R_{SENSE}), When the S_{SENSE} pin voltage larger than 110mV, the current limit is happened that driver can be turned off until small than 90mV. The current limit set according to the following formula:

$$\text{Current Limit (A)} = \frac{110mV}{R_{SENSE}}$$

The maximum output current table is shown as below; please refer the table to design.

R _{SENSE} (Ω)	Current Limit (A)	Maximum Output Current (A)
25m	4.4	4.1
30m	3.66	3.3
50m	2.2	1.9
75m	1.46	1.1

Inductor Selection

For most designs, the different frequency can be reducing the inductor value; The TS2581 is suggested 22μH to 100μH for 100K to 300KHz frequencies. Please refer the below table to design.

L1 recommend value (V _{IN} =10~30V, V _{OUT} =5V, I _{OUT} =2A)	
L1 Value (H)	68~100uF

Where is inductor Ripple Current. Large value inductors lower ripple current and small value inductors result in high ripple currents. Choose inductor ripple current approximately 20% of the maximum load current 3A, ΔIL=0.6A. The DC current rating of the inductor should be at least equal to the maximum load current plus half the ripple current to prevent core saturation (3A+0.3A).

Input Capacitor Selection

This capacitor should be located close to the IC using short leads and the voltage rating should be approximately 1.5 times the maximum input voltage. The RMS current rating requirement for the input capacitor of a buck regulator is approximately 1/2 the DC load current. A low ESR input capacitor sized for maximum RMS current must be used. A 220~470μF low ESR capacitor for most applications is sufficient.

Application Information (Continue)

Output Capacitor Selection

The output capacitor is required to filter the output and provide regulator loop stability. The important capacitor parameters are; the 100 KHz Equivalent Series Resistance (ESR), the RMS ripples current rating, voltage rating, and capacitance value. For the output capacitor, the ESR value is the most important parameter. The ESR can be calculated from the following formula.

$$V_{RIPPLE} = \Delta I_L \times ESR = 0.6A \times 80m\Omega = 48mV$$

An aluminum electrolytic capacitor's ESR value is related to the capacitance and its voltage rating. In most case, higher voltage electrolytic capacitors have lower ESR values. Most of the time, capacitors with much higher voltage ratings may be needed to provide the low ESR values required for low output ripple voltage. System stability is depending on output capacitor's ESR, Correct to choose output capacitor's ESR is very important. It is recommended to using a 220~470µF, the ESR values range is 40~130mΩ.

EN/CT

The pin is enable/shutdown and auto restart control functions. When system is normal operating, this pin is enable/shutdown function. Pulling this pin below a threshold voltage of under 0.3V shuts the regulator off, and pulling this pin from 0.5V to 1.5V turns the regulator on. However when V_{OUT} is short (V_{FB}<0.4V), the auto restart function can be started that restart the regulator cycle by cycle. The cycle time is set by outside capacitor (C6). Please refer the below waveform and formula, the t₂ cycle is regulator off time and t₁ cycle is current limit time. The charge-current is 30uA and discharge-current is 1.3uA.

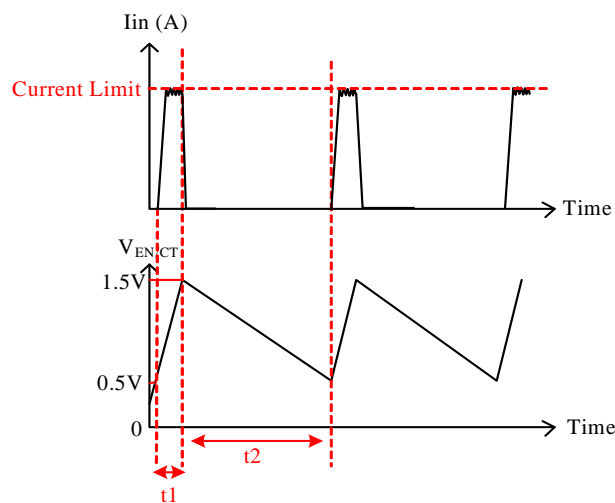

Thermal Consideration

The SOP-8L package needs a heat sink under most conditions. The heat sink connect exposed pad of TS2581 to obtain best effect. The size of the heat sink depends on the input voltage, the output voltage, the load current and the ambient temperature.

SOP-8 Mechanical Drawing

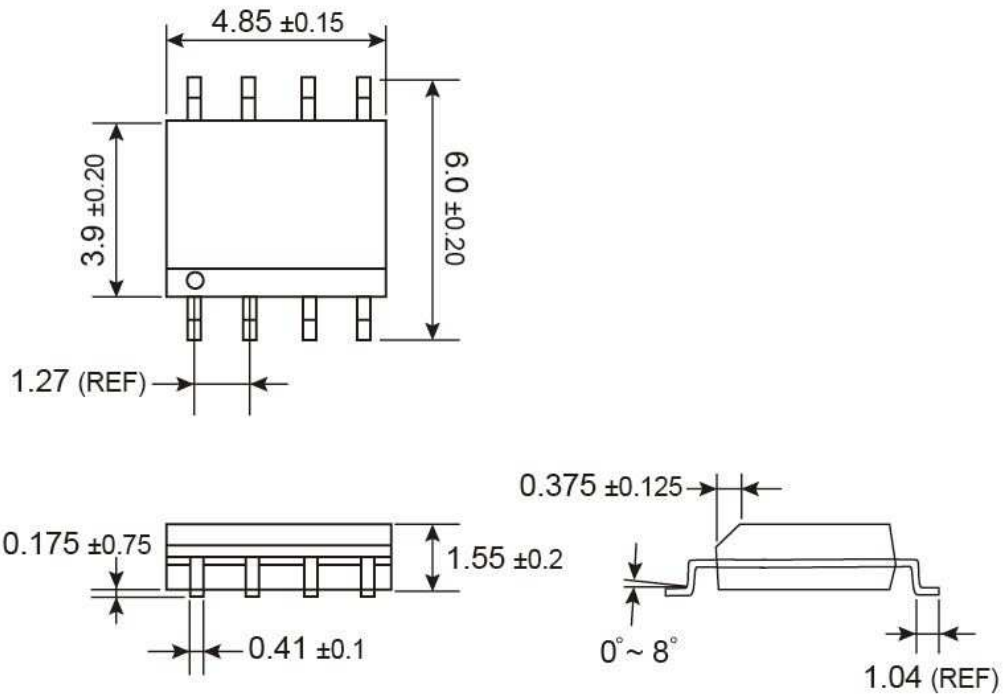

Unit: Millimeters

Marking Diagram

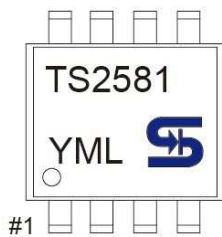

- Y** = Year Code
- M** = Month Code for Halogen Free Product
(**O**=Jan, **P**=Feb, **Q**=Mar, **R**=Apr, **S**=May, **T**=Jun, **U**=Jul, **V**=Aug, **W**=Sep, **X**=Oct, **Y**=Nov, **Z**=Dec)
- L** = Lot Code

Notice

Specifications of the products displayed herein are subject to change without notice. TSC or anyone on its behalf, assumes no responsibility or liability for any errors or inaccuracies.

Information contained herein is intended to provide a product description only. No license, express or implied, to any intellectual property rights is granted by this document. Except as provided in TSC's terms and conditions of sale for such products, TSC assumes no liability whatsoever, and disclaims any express or implied warranty, relating to sale and/or use of TSC products including liability or warranties relating to fitness for a particular purpose, merchantability, or infringement of any patent, copyright, or other intellectual property right.

The products shown herein are not designed for use in medical, life-saving, or life-sustaining applications. Customers using or selling these products for use in such applications do so at their own risk and agree to fully indemnify TSC for any damages resulting from such improper use or sale.