

**SPECIFICATION
FOR
LCD Module**

Customer P/N:

Santek P/N: ST0700O3W-RSLW-F

DOC. Revision: RS01

Customer Approval:

--

	SIGNATURE	DATE
PREPARED BY	Vivian Huang	2016-08-23
CHECKED BY	YF Zhou	2016-08-23
APPROVED BY	Natty Lee	2016-Aug-25

Document Revision History

Version	Revise Date	Description	Changed by
RS01	2016.08.23	Initial release	Vivian Huang

Santek - CONFIDENTIAL

Table of Contents

1. OVERVIEW	4
2. ABSOLUTE MAXIMUM RATINGS	5
3. ELECTRICAL CHARACTERISTICS	6
3.1. Typical Operation Conditions	6
3.2. Current Consumption	6
3.3. Power、Signal sequence	7
3.4. Timing characteristics of input signal	8
3.5. Backlight	11
4. INTERFACE CONNECTION	12
4.1 CN1(Input Signal)	12
5. MECHANICAL DIMENSION	14
6. OPTICAL CHARACTERISTICS	15
7. RELIABILITY TEST	17
7.1 Temperature and humidity	17
7.2 Shock and Vibration	17
7.3 Electrostatic Discharge	17
7.4 Judgment standard	17
8. PACKING FORM	18
9. WARRANTY	18

1. OVERVIEW

ST0700O3W-RSLW-F is 7" color TFT-LCD (Thin Film Transistor Liquid Crystal Display) module composed of LCD panel, driver ICs, control circuit and LED backlight. By applying 800×480 images are displayed on the 7" diagonal screen. Display 16.7Mcolors by R.G.B signal input.

General specification are summarized in the following table:

ITEM	SPECIFICATION			
Display Area (mm)	154.08(H) x 85.92(V)			
Number of Pixels	800(H) × 3 (RGB) × 480(V)			
Pixel Pitch (mm)	0.1926(H) x 0.1790(V)			
Color Pixel Arrangement	RGB vertical stripe			
Display Mode	Normally white			
Number of Colors	16.2M			
Brightness (cd/m ²)	500nit(typ)			
Response Time (ms)	25ms(typ.)			
Contrast Ratio	500:1			
Viewing Angle (CR ≧ 10)	140degree (Horizontal.)			
	120degree (Vertical)			
Power Consumption (W)	TBD			
Interface connection	TTL			
Module Size (mm)		Min.	Typ.	Max.
	Horizontal (H)	164.6	164.9	165.2
	Vertical (V)	99.7	100	100.3
	Depth (D) w/o FPC	5.4	5.7	6.0
Module Weight (g)	150(typ)			
Backlight Unit	LED			
Surface Treatment	Anti-Glare,3H			

2. ABSOLUTE MAXIMUM RATINGS

The following are maximum values which, if exceeded, may cause faulty operation or damage to the unit.

Item	Symbol	Min.	Max.	Unit	Note
Digital Supply Voltage	VDD VDD_LVDS	-0.3	+5.0	V	
Analog Supply Voltage	AVDD	-0.5	+13.5	V	
Gate On Voltage	VGH	-0.3	+42	V	
Gate Off Voltage	VGL	-20	+0.3	V	
Gate On-Gate Off Voltage	VGH-VGL	12	40	V	
Forward Current (per LED)	If	-	30	mA	
Reverse Voltage (per LED)	VR	-	5	V	
Pulse forward current (per LED)	I _{fp}	-	100	mA	Note *2)
Operation Temperature	T _{op}	-20	70	°C	Note *1)
Storage Temperature	T _{stg}	-30	80	°C	Note *1)

Note:

*1) If users use the product out of the operation and storage range, it will have quality issues.

*2) I_{fp} Conditions : Pulse Width ≤ 10msec, Duty ≤ 1/10

*3) Each one of LED operation must be follow diagram of Ambient Temperature and Allowable Forward Current.

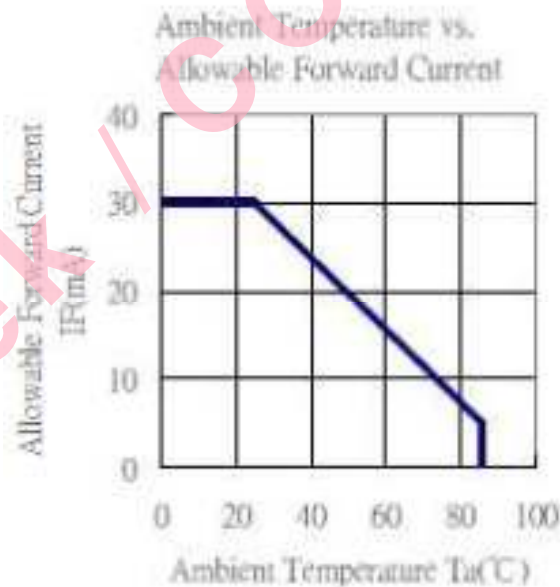

*4) If users use the product out of the environmental operation range (temperature and humidity), it will have visual quality concerns.

3. ELECTRICAL CHARACTERISTICS

3.1. Typical Operation Conditions

Item	Symbol	MIN	TYP	MAX	UNIT	NOTE
Digital Supply Voltage	DVDD	3	3.3	3.6	V	
Analog Supply Voltage	AVDD	9.4	9.6	9.8	V	
Gate On Voltage	VGH	17	18	19	V	
Gate Off Voltage	VGL	-6.6	-6	-5.4	V	
Common Voltage	VCOM	3.8	4	4.2	V	Note 1
Logic Input Voltage	VIH	0.7*DVDD	-	DVDD	V	
	VIL	GND	-	0.3*DVDD	V	

Note1: Please adjust VCOM to make the flicker level be minimum.

3.2. Current Consumption

Item	Symbol	Condition	Min.	Typ.	Max.	Unit	Note
Gate on current	IVGH	VGH = 18V	-	0.5	1	mA	Note 1
Gate off current	IVGL	VGL = -6V	-	0.5	1	mA	Note 1
Digital current	IVDD	DVDD = 3.3V	-	8	15	mA	Note 1
Analog current	IAVDD	AVDD = 9.6V	-	30	40	mA	Note 1
Total Power Consumption	PC		-	327	458	mW	Note 1

Note 1: Typical: Under 256 gray pattern
Maximum: Under black pattern



256 gray pattern

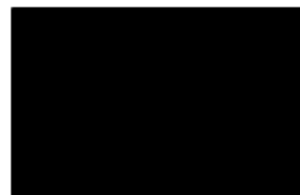

Black Pattern

3.3. Power、Signal sequence

Power On: DVDD→AVDD/VGL→VGH→Video & Logic Signal→Backlight

Power Off: Backlight→Video & Logic Signal→VGH→AVDD/VGL→DVDD

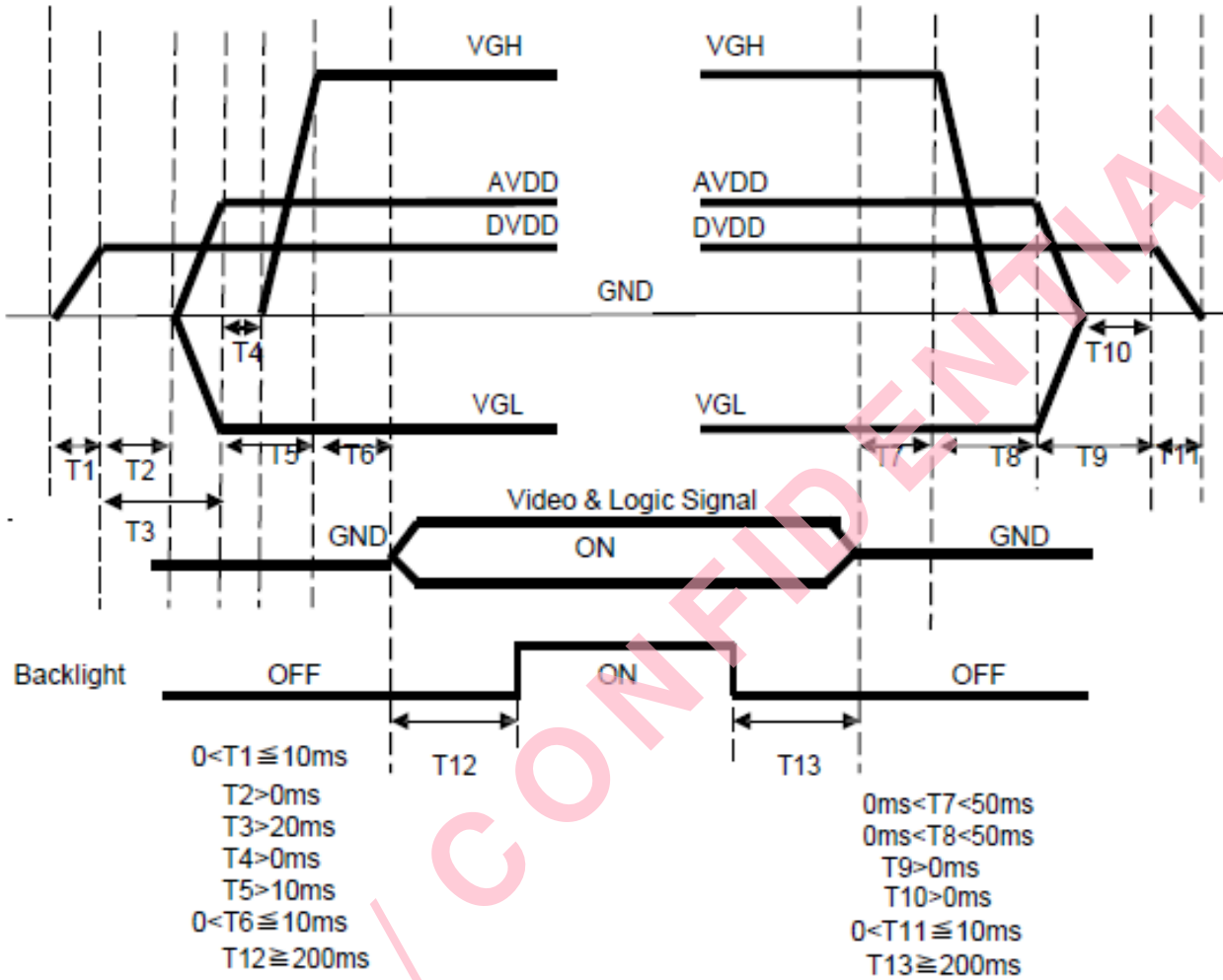

3.4. Timing characteristics of input signals

ITEM		SYMBOL	MIN.	TYP.	MAX.	UNIT	Note
DCLK	Dot Clock	$1/t_{CLK}$	29	33	38	MHz	
	DCLK pulse duty	T_{cwh}	40	50	60	%	
DE	Setup Time	T_{esu}	8	-	-	ns	
	Hold time	T_{ehd}	8	-	-	ns	
	Horizontal Period	t_H	1026	1056	1086	t_{CLK}	
	Horizontal Valid	t_{HA}	800			t_{CLK}	
	Horizontal Blank	t_{HB}	226	256	286	t_{CLK}	
	Vertical Period	t_V	515	525	535	t_H	
	Vertical Valid	t_{VA}	480			t_H	
	Vertical Blank	t_{VB}	35	45	55	t_H	
SYNC	HSYNC Setup Time	T_{hst}	8	-	-	ns	
	HSYNC Hold Time	T_{hhd}	8	-	-	ns	
	VSYNC Setup Time	T_{vst}	8	-	-	ns	
	VSYNC Hold Time	T_{vhd}	8	-	-	ns	
	Horizontal Period	t_h	1026	1056	1086	t_{CLK}	
	Horizontal Pulse Width	t_{hpw}	-	30	-	t_{CLK}	$t_{hb} + t_{hpw} = 46DCLK$ is fixed
	Horizontal Back Porch	t_{hb}	-	16	-	t_{CLK}	
	Horizontal Front Porch	t_{hfp}	180	210	240	t_{CLK}	
	Horizontal Valid	t_{hd}	800			t_{CLK}	
	Vertical Period	t_v	515	525	535	t_h	
	Vertical Pulse Width	t_{vpw}	-	13	-	t_h	$t_{vpw} + t_{vb} = 23t_h$ is fixed
	Vertical Back Porch	t_{vb}	-	10	-	t_h	
	Vertical Front Porch	t_{vfp}	12	22	32	t_h	
	Vertical Valid	t_{vd}	480			t_h	
DATA	Setup Time	T_{dsu}	8	-	-	ns	
	Hold Time	T_{dhd}	8	-	-	ns	

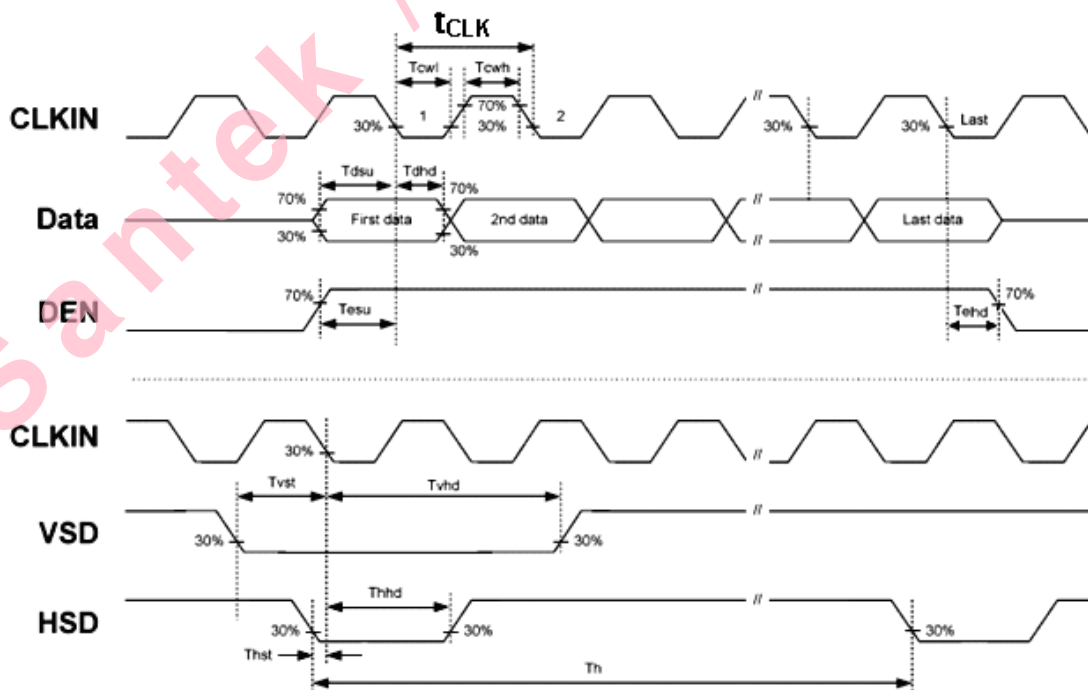

DE mode

Horizontal timing:

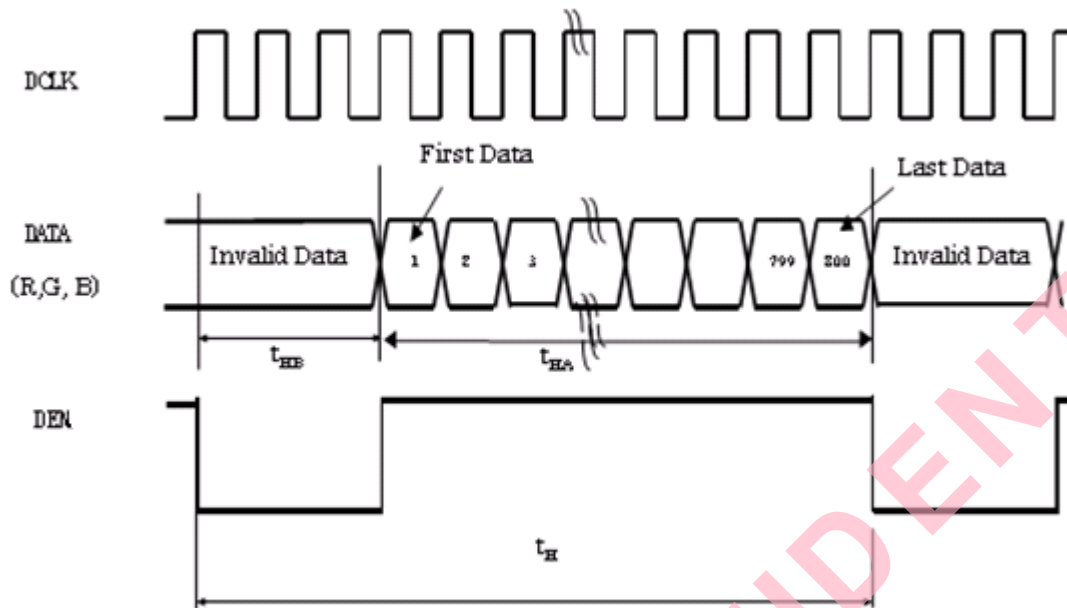

Vertical timing:

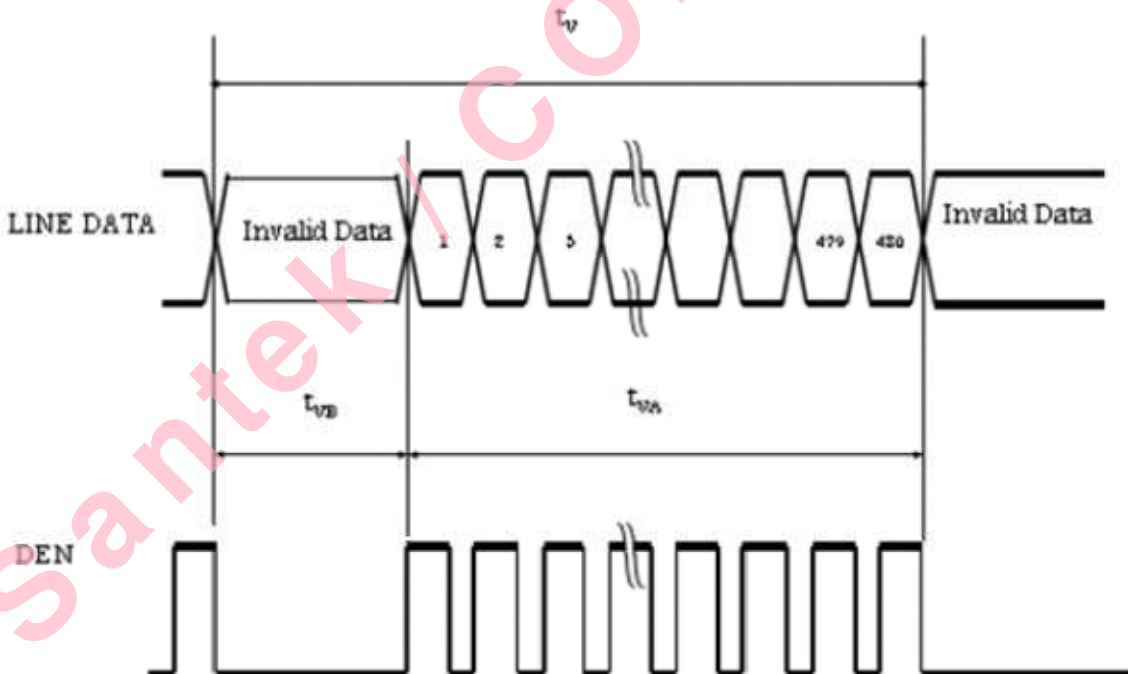

SYNC mode

Horizontal timing:

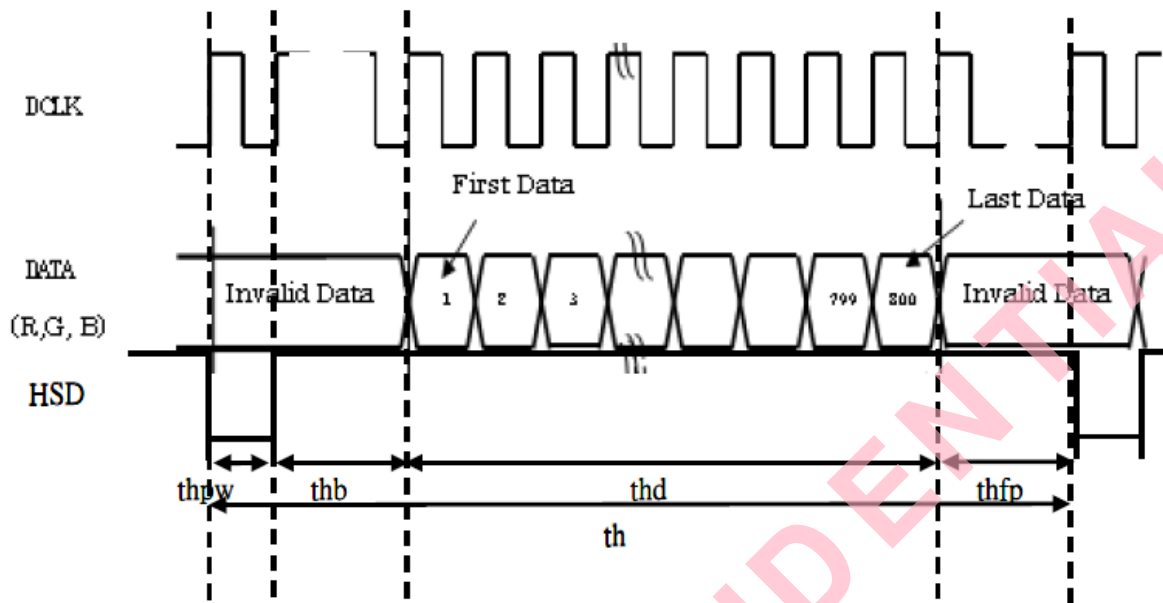

Vertical timing:

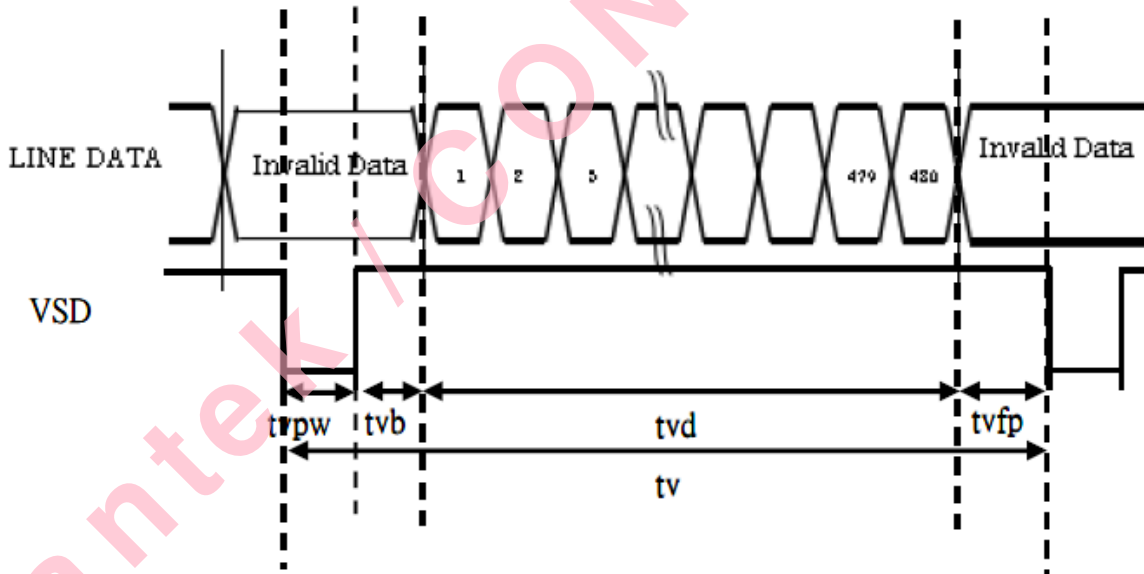

3.5. Backlight

Ta=25°C

ITEM	SYMBOL	CONDITIONS	MIN	TYP	MAX	UNIT	NOTE
LED current	IL	Ta=25°C (20mA/series)	--	180	--	mA	
LED voltage	VL	Ta=25°C (20mA/series)	8.2	8.6	9.2	V	
Power consumption	WL	Ta=25°C (20mA/series)	--	1.548	--	W	
LED Lifetime	-	Ta=25°C IF=20mA	30000	--	--	Hr	

Remarks:

*1) LED Circuit Diagram

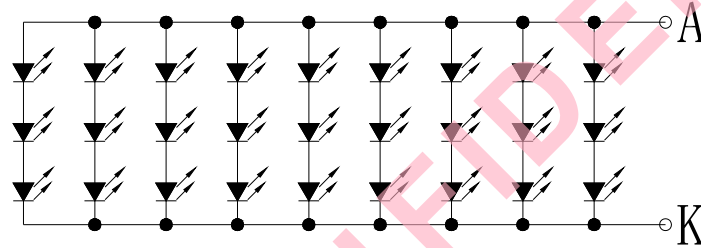

(3S9P=27LED)

*2) A: Anode(+), K: Cathode(-)

*3) Suggestion: Using the constant current control to avoid the leakage light and brightness quality issue.

*4) Definition of Led lifetime: Luminance < Initial luminance 50%.

4. INTERFACE CONNECTION

4.1. CN1 (Input Signal)

PIN NO.	SYMBOL	DESCRIPTION
1	LED+	LED Anode
2	LED+	LED Anode
3	LED-	LED Cathode
4	LED-	LED Cathode
5	GND	Ground
6	VCOM	Common Voltage
7	DVDD	Digital Power
8	MODE	DE/SYNC mode select. Normally pull high H: DE mode. L: HSD/VSD mode
9	DEN	Data Enable signal
10	VSD	Vertical sync input. Negative polarity
11	HSD	Horizontal sync input. Negative polarity
12	B7	Blue Data Input(MSB)
13	B6	Blue Data Input
14	B5	Blue Data Input
15	B4	Blue Data Input
16	B3	Blue Data Input
17	B2	Blue Data Input
18	B1	Blue Data Input
19	B0	Blue Data input(LSB)
20	G7	Green Data Input(MSB)
21	G6	Green Data Input
22	G5	Green Data Input
23	G4	Green Data Input
24	G3	Green Data Input
25	G2	Green Data Input
26	G1	Green Data Input
27	G0	Green Data Input(LSB)
28	R7	Red Data Input(MSB)
29	R6	Red Data Input
30	R5	Red Data Input
31	R4	Red Data Input
32	R3	Red Data Input
33	R2	Red Data Input
34	R1	Red Data Input
35	R0	Red Data Input(LSB)
36	GND	Power ground
37	DCLK	Clock input

38	GND	Power ground
39	SHLR	Left or Right Display Control
40	UPDN	Up / Down Display Control
41	VGH	Positive Power for TFT
42	VGL	Negative Power for TFT
43	AVDD	Analog Power
44	RESET	Global reset pin. Active low to enter reset state. Suggest to connecting with an RC reset circuit for stability. Normally pull high. (R=10KΩ, C=1μF)
45	NC	Not connect
46	VCOM	Common Voltage
47	DITH	Dithering setting DITH="H" 6bit resolution(last 2 bit of input data truncated) DITH="L" 8bit resolution(default setting)
48	GND	Power ground
49	NC	Not connect
50	NC	Not connect

【Note1】 SHLR: left or right setting

UPDN: up or down setting

UD	LR	FUNCTION
DVDD	GND	Left→Right , Up→Down(default)
GND	GND	Right→Left , Up→Down
DVDD	DVDD	Left→Right , Down→Up
GND	DVDD	Right→Left , Down→Up

Definition of scanning direction

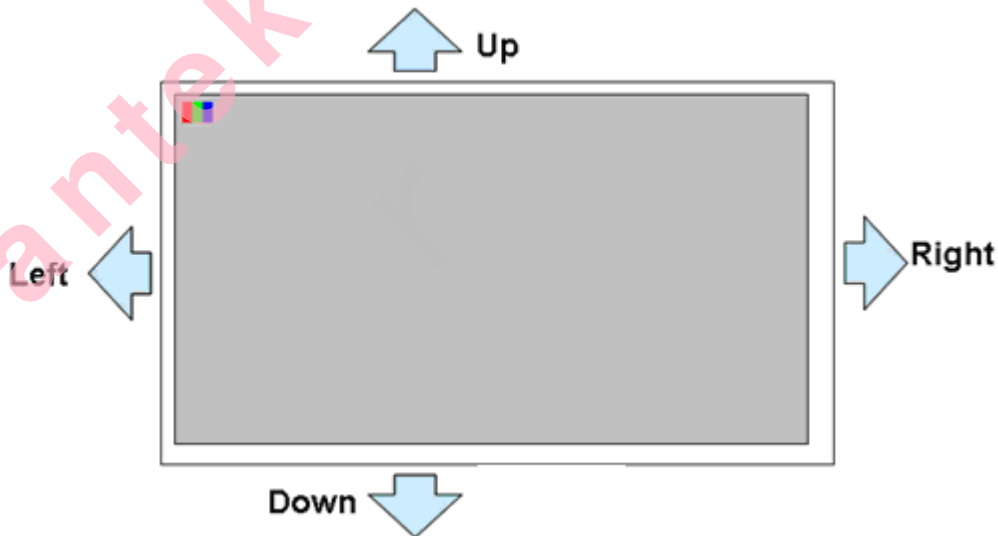

5. MECHANICAL DIMENSION

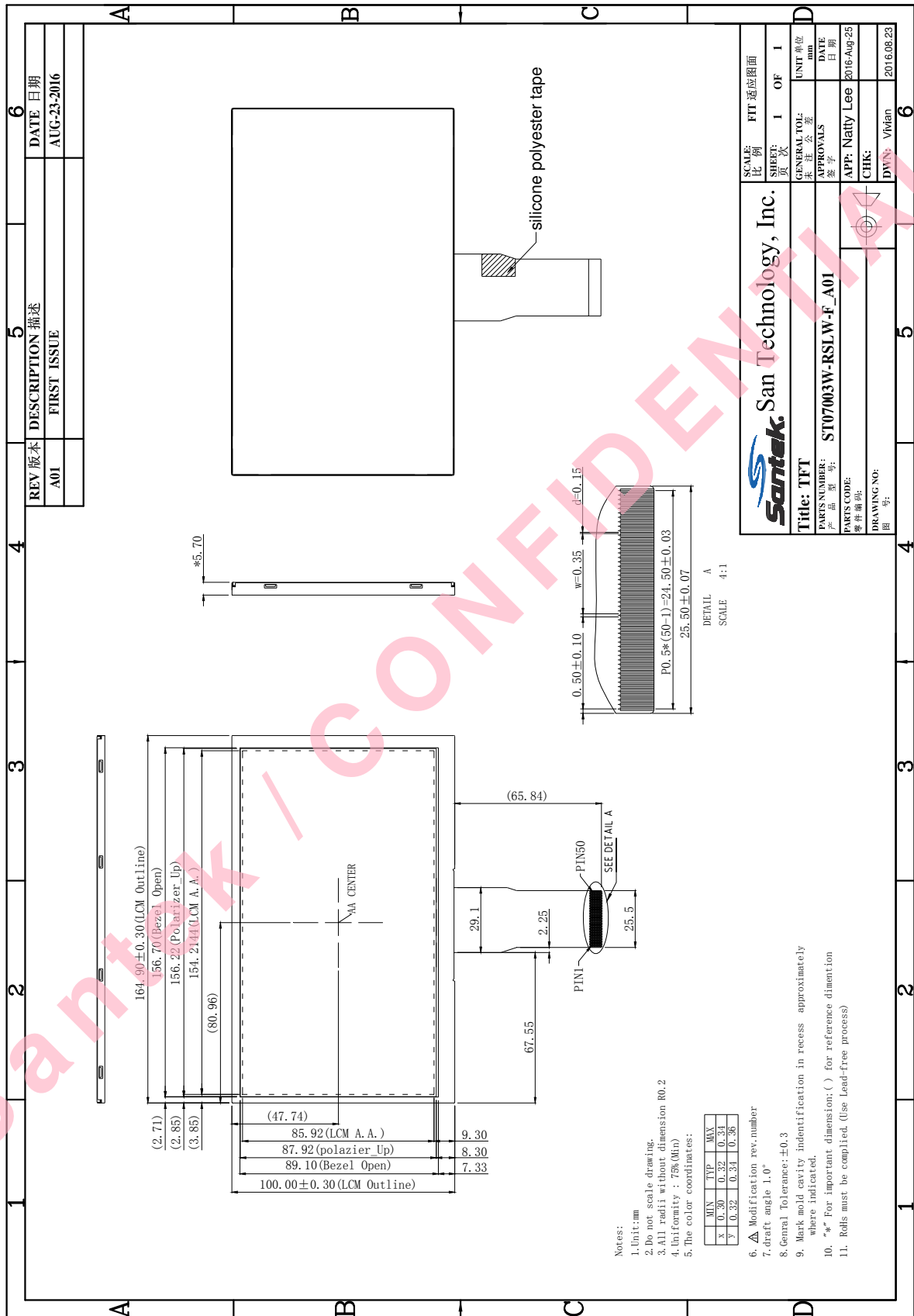

- Notes:
- Unit: mm
 - Do not scale drawing.
 - All radii without dimension R0.2
 - Uniformity : 75K(Mh)
 - The color coordinates:
- | | MIN | TYP | MAX |
|---|------|------|------|
| x | 0.30 | 0.32 | 0.34 |
| y | 0.32 | 0.34 | 0.36 |
- Modification rev. number
 - draft angle 1.0°
 - General Tolerance: ±0.3
 - Mark mold cavity identification in recess approximately where indicated.
 - * For important dimension; () for reference dimension
 - Rolls must be compiled (Use Lead-free process)

6. OPTICAL CHARACTERISTICS

Ta = 25°C, VCC=3.3V

ITEM	SYMBOL	CONDITIONS	MIN	TYP	MAX	UNIT	NOTE	
Panel Transmittance	T		4.8	5.1	--	%		
Contrast Ratio	CR	Point-5	400	500		--	1,2,3	
Luminance(CEN)	LW	Point-5	450	500		cd/m ²	1,3	
Luminance Uniformity	ΔL		70	80		%	1,3	
Response Time (White - Black)	Tr +Tf	Point-5	-	25	40	ms	1,3,5	
NTSC	-	Point-5	45	50	-	%	1,3	
Viewing Angle	Horizontal	Left(ψ)	CR ≥ 10 Point-5	60	70	--	°	1,3
		Right(ψ)		60	70	--	°	
	Vertical	Upper(θ)		45	55	--	°	1,2,4
		Down(θ)		55	65	--	°	
Color Coordinate	White	Wx	Point-5	0.273	0.313	0.353	--	1,3
		Wy		0.289	0.329	0.369		
	Red	Rx		0.562	0.602	0.642		
		Ry		0.297	0.337	0.377		
	Green	Gx		0.309	0.349	0.389		
		Gy		0.547	0.587	0.627		
	Blue	Bx		0.123	0.163	0.203		
		By		0.074	0.114	0.154		

Note1: Measure condition: 25°C±2°C, 60±10%RH, under 10 Lux in the dark room. BM-5A (TOPCON), viewing angle 2°, IL=180 mA (Backlight current), measurement after lighting on 10 mins.

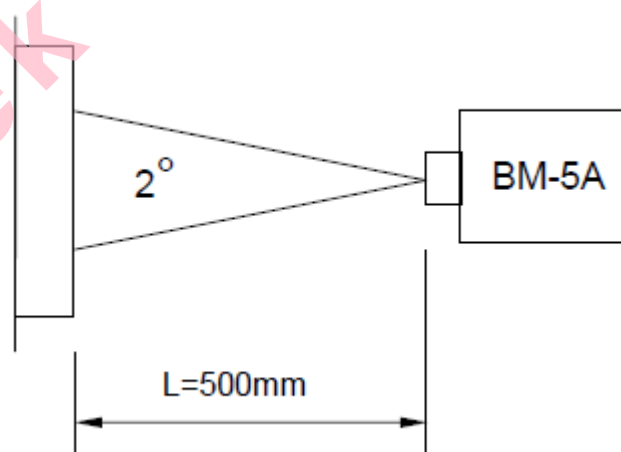

Note2: Definition of contrast ratio:

Contrast Ratio (CR) = (White) Luminance of ON ÷ (Black) Luminance of OFF

Note3: Definition of luminance: Measure white luminance on the point 5 as figure.7-1

Definition of Luminance Uniformity: Measure white luminance on the point1~9 as figure.7-1

$$\Delta L = [L(\text{MIN})/L(\text{MAX})] \times 100$$

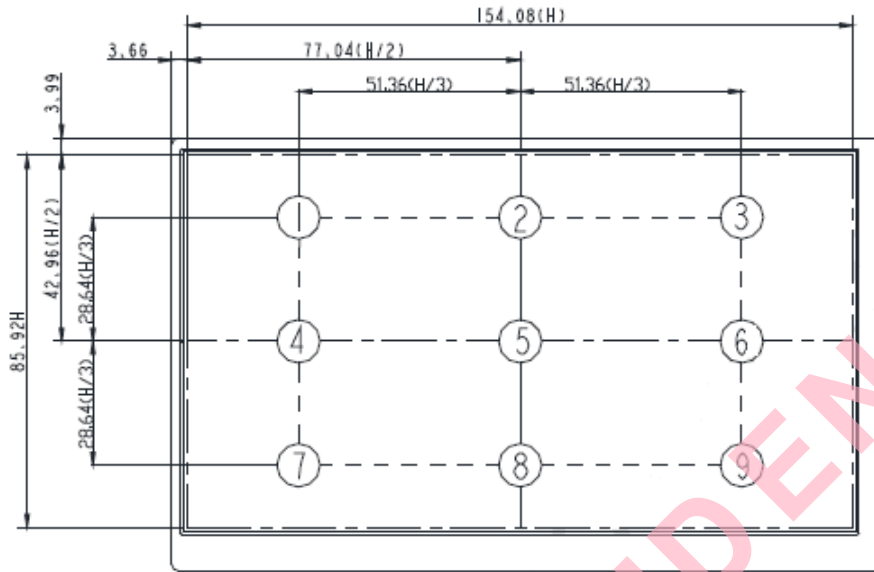

Fig.7-1 Measuring point

Note 4: Definition of Viewing Angle (θ , ψ), refer to Fig.7-2 as below:

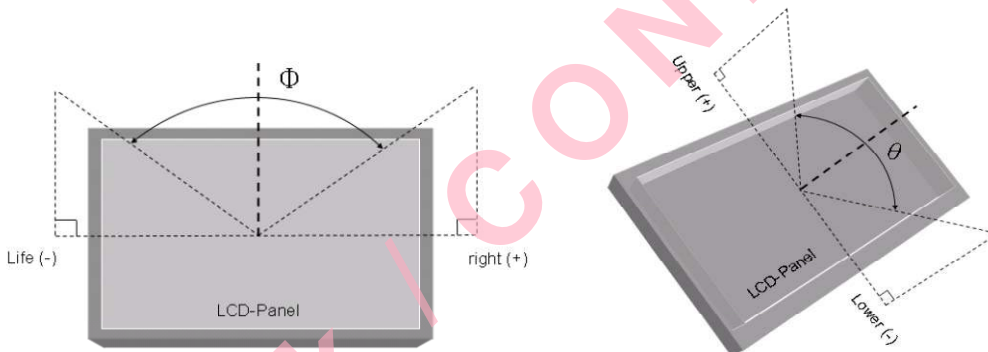

Fig.7-2 Definition of Viewing Angle

Note5: Definition of Response Time.(White-Black)

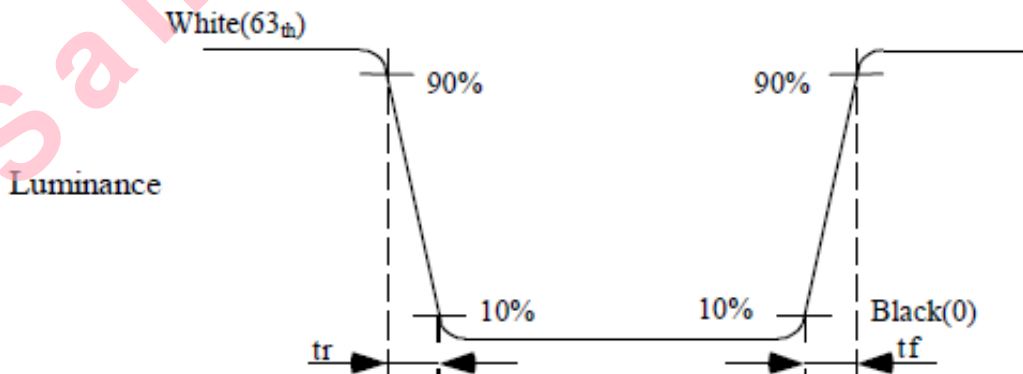

Fig.7-3 Definition of Response Time(White-Black)

7. RELIABILITY TEST

7.1. Temperature and humidity

TEST ITEMS	CONDITIONS	NOTE
High Temperature Operation	70°C ;240hrs	
High Temperature Storage	80°C ; 240hrs	
High Temperature High Humidity Operation	60°C ; 90%RH ;240hrs	No condensation
Low Temperature Operation	-20°C ; 240hrs	Backlight unit always turn on
Low Temperature Storage	-30°C ; 240hrs	
Thermal Shock	-20°C(0.5hr) ~ 70°C(0.5hr) ; 100 Cycles	
Image Sticking	25°C ; 4hrs	
MTBF	200,00hrs	

Note 1:

Condition of Image Sticking test: 25 °C± 2 °C

Operation with test pattern sustained for 4 hrs, then change to mid-gray pattern immediately.

After 5 mins, the mura must be disappeared completely .

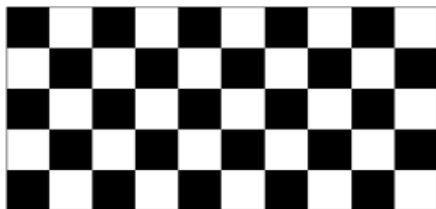

Image Sticking -pattern



Mid-Gray pattern

7.2. Shock and Vibration

ITEMS	CONDITIONS
Shock (Non-operation)	<ul style="list-style-type: none"> ● Shock level: 980m/s²(equal to 100G). ● Waveform:1/2 Sine wave,6msec. ● ±X,±Y,±Z,each axis 1 times
Vibration (Non-operation)	<ul style="list-style-type: none"> ● Frequency range:8~33.3Hz ● Stoke: 1.3 mm ● Vibration: sinusoidal wave, perpendicular axis(both x, z axis: 2Hrs,y axis 4Hrs). ● Sweep: 2.9G,33.3 Hz -400 Hz ● Cycle: 15 min

7.3. Electrostatic Discharge

TEST ITEM	CONDITIONS	Note
ESD	150pF, 330Ω, ±8kV&±15kV air& contact test	1
	200pF, 0Ω, ±200V contact test	2

Note: Measure

1: LCD glass and metal bezel

2: IF connector pins

7.4. Judgment standard

The Judgment of the above test should be made as follow:

Pass: Normal display image and no line defect.

Partial transformation of the module parts should be ignored.

Fail: No display image, Function NG, or line defects.

8. PACKING FORM

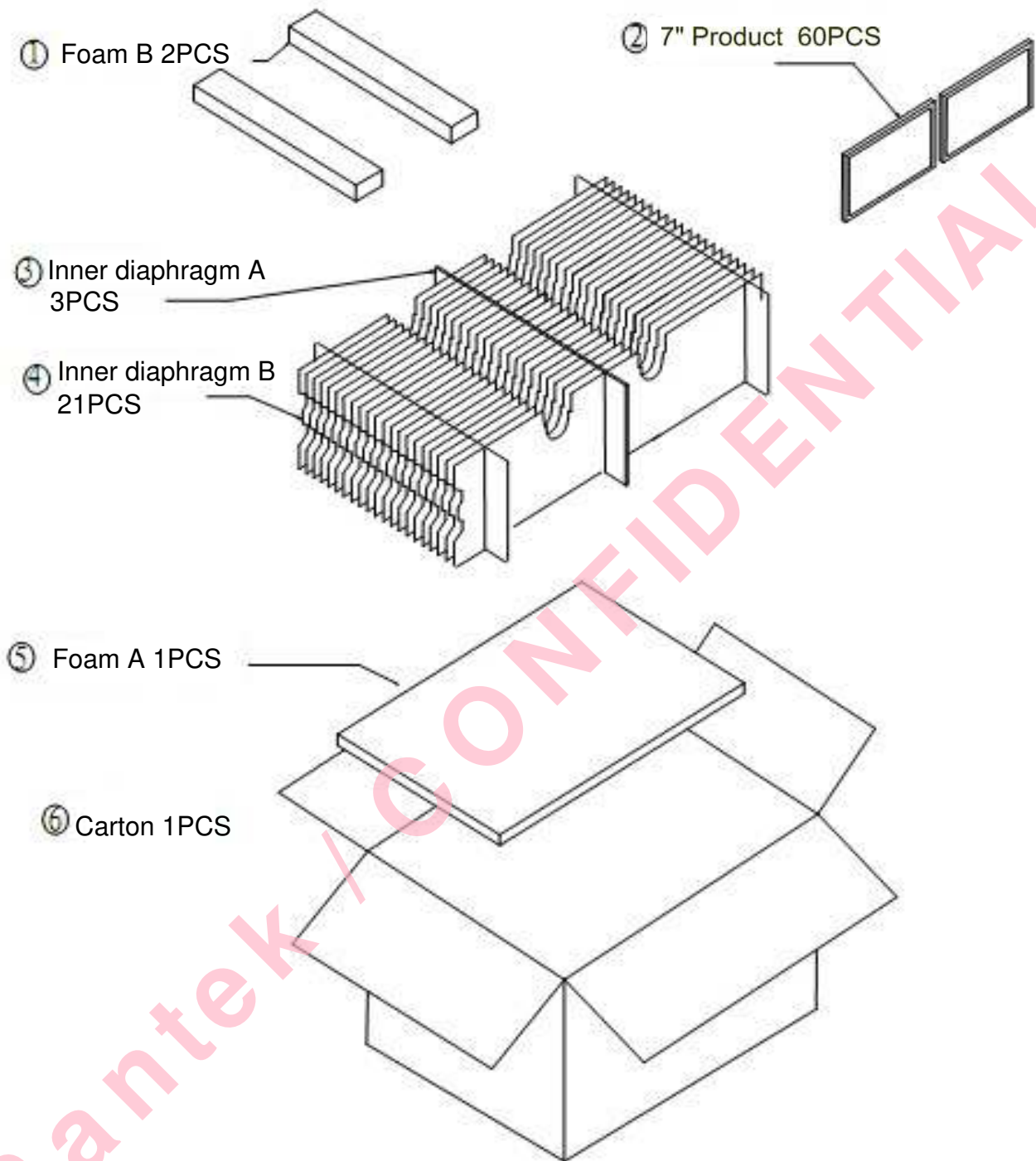

9. WARRANTY

9.1 The period is within 12 months since the date of shipping out under normal using and storage conditions.

9.2 The warranty will be avoided in case of defect induced by customer