

PRELIMINARY IN P/N DIR

CAUTION: PRESSURE SENSITIVE ASSEMBLY  
AVOID APPLYING PRESSURE TO LED  
DURING PANEL ASSEMBLY.

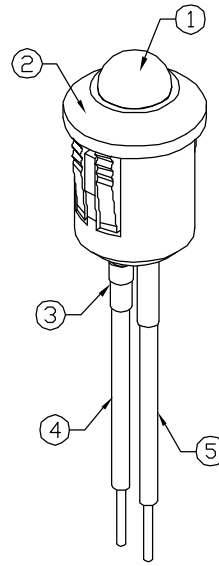

PANEL CUTOUT

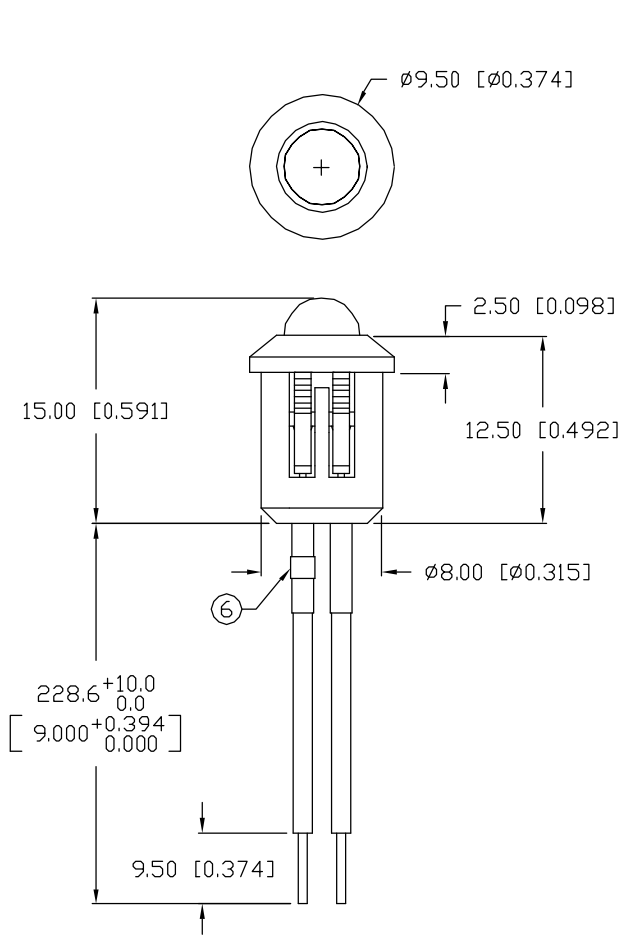
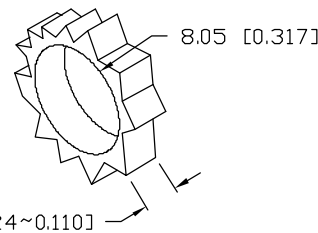

ELECTRO-OPTICAL CHARACTERISTICS		T <sub>A</sub> =25°C		V <sub>f</sub> =28V	
PARAMETER	MIN	TYP	MAX	UNITS	TEST COND
PEAK WAVELENGTH		WHITE		nm	
FORWARD VOLTAGE		28		V <sub>f</sub>	
REVERSE VOLTAGE	5.0			V <sub>r</sub>	I <sub>r</sub> =100μA
AXIAL INTENSITY		200		mcd	V <sub>f</sub> =28V
VIEWING ANGLE		34		2x theta	
EMITTED COLOR:	WHITE				
EPOXY LENS FINISH:	MILKY WHITE DIFFUSED				

LIMITS OF SAFE OPERATION AT 25°C PER DIE		
PARAMETER	MAX	UNITS
PEAK FORWARD VOLTAGE	29.5	V
STEADY CURRENT	18	mA
POWER DISSIPATION	500	mW
DERATE FROM 25°C	-1.2	mW/°C
OPERATING, STORAGE TEMP.	-40 TO +85	°C
SOLDERING TEMP.	+260	°C
2.0mm FROM BODY		3 SEC. MAX

NOTES:

1. SSL-LX5093UW, WHITE LED. TRIM LEADS TO 5mm.
2. SSH-RTF5010, BLACK HOLDER.
3. LXP-HEATSHRINK-3, (2 PCS.) 1/8" x 50mm.
4. ANODE LEAD: LXP-WST24RDT0C, CUT 180mm LONG, STRIP ENDS 3mm & 9.5mm.
5. CATHODE LEAD: LXP-WST24BLT0C, CUT 210mm LONG, STRIP ENDS 3mm & 9.5mm.
6. LXP-RES 2700 1/2W, CUT 22-24mm.



UNCONTROLLED DOCUMENT

\*UNLESS OTHERWISE SPECIFIED TOLERANCES PER DECIMAL PRECISION ARE: X=±1 (±0.039), X.X=±0.5 (±0.020), X.XX=±0.25 (±0.010), X.XXX=±0.127 (±0.005). LEAD SIZE=±0.05 (±0.002), LEAD LENGTH=±0.75 (±0.030). MIN=+DECIMAL PRECISION MAX.=+0.00 -DECIMAL PRECISION

REV.	PART NUMBER
	SSI-LXR5010UW41249

**CONFIDENTIAL INFORMATION**  
THE INFORMATION CONTAINED IN THIS DOCUMENT IS THE PROPERTY OF LUMEX INC. EXCEPT AS SPECIFICALLY AUTHORIZED IN WRITING BY LUMEX INC., THE HOLDER OF THIS DOCUMENT SHALL KEEP ALL INFORMATION CONTAINED HEREIN CONFIDENTIAL AND SHALL PROTECT SAME IN WHOLE OR IN PART FROM DISCLOSURE AND DISSEMINATION TO ALL THIRD PARTIES.



290 E. HELEN ROAD  
PALATINE, IL 60067-6976  
PHONE: +1.847.359.2790  
US WEB: www.lumex.com  
TW WEB: www.lumex.com.tw

T-5mm, ULTRA WHITE LED PANEL INDICATOR,  
WHITE DIFFUSED LENS, 9" WIRE LEADS, 28 VOLTS.

**RELIABILITY NOTE**  
OUR MANY YEARS OF EXPERIENCE DATA ACCUMULATION INDICATE THAT SOLDER HEAT IS A MAJOR CAUSE OF EARLY AND FUTURE FAILURE. PLEASE PAY ATTENTION TO YOUR SOLDERING PROCESS.

DRAWN BY: JN	CHECKED BY:	APPROVED BY:	DATE: 09.04.08
			PAGE: 1 OF 1
			SCALE: N/A