



FEATURES:

- Compliant with Intel CK505 Gen II spec
- One high precision PLL for CPU, SSC and N programming
- One high precision PLL for SRC, SSC and N programming
- One high precision PLL for SATA/PCI, and SSC
- One high precision PLL for 96MHz/48MHz
- Push-pull IOs for differential outputs
- Support spread spectrum modulation, -0.5 down spread and others
- Support SMBus block read/write, byte read/write
- Available in TSSOP package

OUTPUTS:

- 2*0.7V differential CPU CLK pair
- 10*0.7V differential SRC CLK pair
- One CPU_ITP/SRC differential clock pair
- One SRC0/DOT96 differential clock pair
- 6*PCI, 33.3MHz
- 1*48MHz
- 1*REF
- 1*SATA

KEY FEATURES

- Internal serial resistor can be enabled by SMBus control register B19b7 to save the board space and material cost
- Direct CPU and SRC clock frequency programming—write the Hex number into Byte [16:18], 1 MHz stepping.
- Linear and smooth transition for the CPU and SRC frequency programming.
- Four Power On hardware modes – see page 6, CFG configuration table 2.
- CV183-2 – When CFG[1:0] = 11, SATA clock power on default is from SRC PLL.

KEY SPECIFICATIONS:

- CPU/SRC CLK cycle to cycle jitter < 85ps
- PCI CLK cycle to cycle jitter < 500ps
- All SRC, SRC[0:11] phase noise < 3.10s RMS, PCIe Gen II
- SRC3, 4, 6, 7, designated PCIe Gen II outputs, nominal interpair skew = 0 ps

FUNCTIONAL BLOCK DIAGRAM

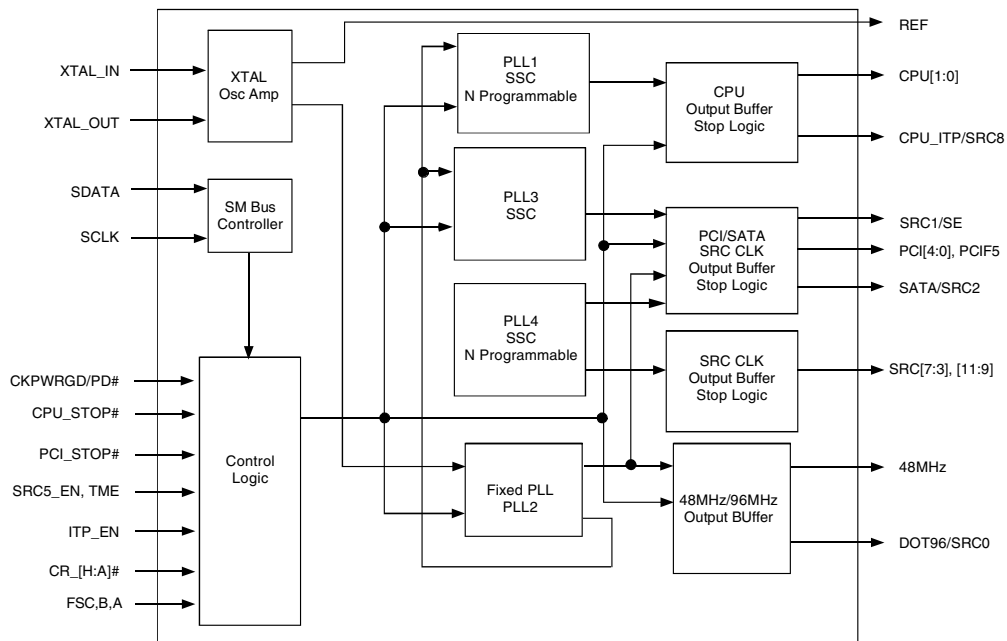

The IDT logo is a registered trademark of Integrated Device Technology, Inc.

PIN CONFIGURATION

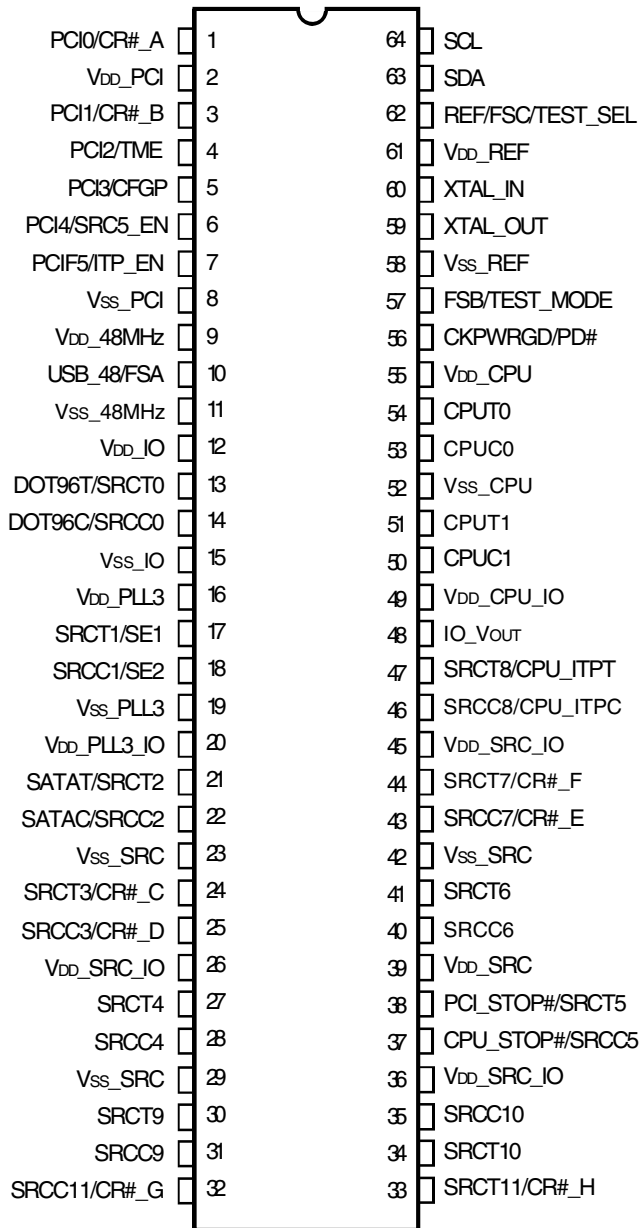

TSSOP
TOP VIEW

PIN DESCRIPTION

Pin #	Name	Type	Description
1	PCI0/CR#_A	I/O	33.33MHz. SRC0, 2 Differential clock output enable, control SRC0 and SRC2, 0 = enable. Mode is selected by SMBus control register. Default is PCI clock mode.
2	V _{DD_PCI}	PWR	3.3V
3	PCI1/CR#_B	I/O	33.33MHz. SRC1, 4 Differential clock output enable, control SRC1 and SRC4, 0 = enable. Mode is selected by SMBus control register. Default is PCI clock mode.
4	PCI2/TME	I/O	33.33MHz. Trust mode enable. HIGH = overclocking disabled. Power-on latch.
5	PCI3/CFGP	OUT	33.33MHz. Clock configuration bit, combined with pin 4 (see CFG Table), power on latch
6	PCI4/SRC5_EN	I/O	33.33MHz. Pin 37, 38 mode selection. Power on latch, HIGH = SRC5, LOW = CPU and PCI Stop#.
7	PCI5/ITP_EN	I/O	33.33MHz. Pin 46, 47 mode selection. Power on latch, HIGH = CPU_ITP, LOW = SRC8.
8	V _{SS_PCI}	GND	GND
9	V _{DD_48}	PWR	3.3V
10	USB 48/FS_A	I/O	48MHz, frequency select, power on latch
11	V _{SS_48}	GND	GND
12	V _{DD_IO}	PWR	0.8V
13	SRCT0/DOT96T	OUT	Differential output clock. SRC or DOT96. Mode selected by SMBus control register, default is SRC0.
14	SRCC0/DOT96C	OUT	Differential output clock. SRC or DOT96. Mode selected by SMBus control register, default is SRC0.
15	V _{SS_IO}	GND	GND
16	V _{DD_PLL3}	PWR	3.3V
17	SRCT1/SE1	OUT	Differential or single end clock output. Mode selected by SMBus control register. Default is SRC1.
18	SRCC1/SE2	OUT	Differential or single end clock output. Mode selected by SMBus control register. Default is SRC1.
19	V _{SS_PLL3}	GND	GND
20	V _{DD_PLL3_IO}	PWR	0.8V
21	SATAT/SRCT2	OUT	Differential output clock
22	SATAC/SRCC2	OUT	Differential output clock
23	V _{SS_SRC}	GND	GND
24	SRCT3/CR#_C	I/O	SRC clock. SRC differential clock output enable, control SRC0 and SRC2, 0 = enable. Mode selected by SMBus control register. Default is SRC3.
25	SRCC3/CR#_D	I/O	SRC clock. SRC differential clock output enable, control SRC1 and SRC4, 0 = enable. Mode selected by SMBus control register. Default is SRC3.
26	V _{DD_SRC_IO}	PWR	0.8V
27	SRCT4	OUT	Differential output clock
28	SRCC4	OUT	Differential output clock
29	V _{SS_SRC}	GND	GND
30	SRCT9	OUT	Differential output clock
31	SRCC9	OUT	Differential output clock
32	SRCC11/CR#_G	I/O	SRC clock. SRC differential clock output enable, control SRC9, 0 = enable. Mode selected by SMBus control register. Default is SRC11.
33	SRCT11/CR#_H	I/O	SRC clock. SRC differential clock output enable, control SRC10, 0 = enable. Mode selected by SMBus control register. Default is SRC11.
34	SRCT10	OUT	Differential output clock
35	SRCC10	OUT	Differential output clock
36	V _{DD_SRC_IO}	PWR	0.8V
37	CPU_Stop#/SRCC5	I/O	CPU stop, LOW = stop. SRC clock. Mode selected by pin6, SRC5_EN.
38	PCI_Stop#/SRCT5	I/O	PCI stop, LOW = stop. SRC clock. Mode selected by pin6, SRC5_EN.
39	V _{DD_SRC}	PWR	3.3V
40	SRCC6	OUT	Differential output clock
41	SRCT6	OUT	Differential output clock
42	V _{SS_SRC}	GND	GND

PIN DESCRIPTION, CONTINUED

Pin #	Name	Type	Description
43	SRCC7/CR#_E	I/O	SRC clock. SRC differential clock output enable, control SRC6, 0 = enable. Mode selected by SMBus control register. Default is SRC7.
44	SRCT7/CR#_F	I/O	SRC clock. SRC differential clock output enable, control SRC8, 0 = enable. Mode selected by SMBus control register. Default is SRC7.
45	V _{DD} _SRC_IO	PWR	0.8V
46	SRCC8/CPU_ ITPC	OUT	SRC clock. CPU clock. Mode selected by pin7.
47	SRCT8/CPU_ ITPT	OUT	SRC clock. CPU clock. Mode selected by pin7.
48	IO_V _{OUT}	OUT	V _{IO} adjustment
49	V _{DD} _CPU_IO	PWR	0.8V
50	CPUC1	OUT	Differential output clock
51	CPUT1	OUT	Differential output clock
52	V _{SS} _CPU	GND	GND
53	CPUC0	OUT	Differential output clock
54	CPUT0	OUT	Differential output clock
55	V _{DD} _CPU	PWR	3.3V
56	CKPWRGD/PD#	IN	CKPWRGD power good, active LOW, used to latch FSA,B,C, ITP_EN, TME, and SRC5_EN, active HIGH. After, becomes power down, LOW active.
57	FS_B/TestMode	IN	Frequency Select at CKPWRGD assertion. Test Mode selection, see TEST_MODE selection table.q
58	V _{SS} _REF	GND	GND
59	XTAL_OUT	OUT	XTALout
60	XTAL_IN	IN	XTALin
61	V _{DD} _REF	PWR	3.3V
62	REF/FS_C/TestSel	I/O	14.318MHz. Frequency Select at CKPWRGD assertion. Selects test mode if pulled above 2V at CKPWRGD assertion.
63	SDA	I/O	SMBus clock
64	SCL	IN	SMBus data

TEST MODE SELECTION⁽¹⁾

If TEST_SEL sampled above 2V at CKPWRGD active LOW

Test_Mode	CPU	SRC	PCI/F	REF	DOT_96/DOT_SSC	USB
1	REF/N	REF/N	REF/N	REF	REF/N	REF/N
0	Hi-Z	Hi-Z	Hi-Z	Hi-Z	Hi-Z	Hi-Z

NOTE:

1. Once test clock operation has been invoked, TEST_MODE pin will select between the Hi-Z and REF/N, with V_{IH}_FS and V_{IL}_FS thresholds.

FREQUENCY SELECTION

FSC, B, A	CPU	SRC[7:0]	PCI	USB	DOT	REF
101	100	100	33.3	48	96	14.318
001	133	100	33.3	48	96	14.318
011	166	100	33.3	48	96	14.318
010	200	100	33.3	48	96	14.318
000	266	100	33.3	48	96	14.318
100	333	100	33.3	48	96	14.318
110	400	100	33.3	48	96	14.318
111	Reserve	100	33.3	48	96	14.318

ABSOLUTE MAXIMUM RATINGS⁽¹⁾

Symbol	Description	Min	Max	Unit
V _{DDA}	3.3V Core Supply Voltage		4.6	V
V _{DD}	3.3V Logic Input Supply Voltage	GND - 0.5	4.6	V
T _{STG}	Storage Temperature	-65	+150	°C
T _{AMBIENT}	Ambient Operating Temperature	0	+70	°C
T _{CASE}	Case Temperature		+115	°C
ESD Prot	Input ESD Protection Human Body Model	2000		V

NOTE:

1. Stresses greater than those listed under ABSOLUTE MAXIMUM RATINGS may cause permanent damage to the device. This is a stress rating only and functional operation of the device at these or any other conditions above those indicated in the operational sections of this specification is not implied. Exposure to absolute maximum rating conditions for extended periods may affect reliability.

SM PROTOCOL

INDEX BLOCK WRITE PROTOCOL

Bit	# of bits	From	Description
1	1	Master	Start
2-9	8	Master	D2h
10	1	Slave	Ack (Acknowledge)
11-18	8	Master	Register offset byte (starting byte)
19	1	Slave	Ack (Acknowledge)
20-27	8	Master	Byte count, N (0 is not valid)
28	1	Slave	Ack (Acknowledge)
29-36	8	Master	first data byte (Offset data byte)
37	1	Slave	Ack (Acknowledge)
38-45	8	Master	2nd data byte
46	1	Slave	Ack (Acknowledge)
			:
		Master	Nth data byte
		Slave	Acknowledge
		Master	Stop

INDEX BLOCK READ PROTOCOL

Master can stop reading any time by issuing the stop bit without waiting until Nth byte (byte count bit 30-37).

Bit	# of bits	From	Description
1	1	Master	Start
2-9	8	Master	D2h
10	1	Slave	Ack (Acknowledge)
11-18	8	Master	Register offset byte (starting byte)
19	1	Slave	Ack (Acknowledge)
20	1	Master	Repeated Start
21-28	8	Master	D3h
29	1	Slave	Ack (Acknowledge)
30-37	8	Slave	Byte count, N (block read back of N bytes)
38	1	Master	Ack (Acknowledge)
39-46	8	Slave	first data byte (Offset data byte)
47	1	Master	Ack (Acknowledge)
48-55	8	Slave	2nd data byte
			Ack (Acknowledge)
			:
		Master	Ack (Acknowledge)
		Slave	Nth data byte
			Not acknowledge
		Master	Stop

CFGP (PIN5) VOLTAGE DECODING TABLE

state	Min	Typ	Max
Low	0V	0.55V	0.9V
Mid	1.3V	1.65V	2V
High	2.4V	2.75V	VDD

CFG CONFIGURATION TABLE 1

CFGP, TME (pin5, pin4)	CFG1, CFG0 Byte11 bit[7:6]	N programming enable Byte16 bit 3
Low, 0	0, 0	1
Low, 1	0, 0	0
Mid, 0	0, 1	1
Mid, 1	0, 1	0
High, 0	1, 0	1
High, 1	1, 1	1

CFG CONFIGURATION TABLE 2

CFG[1: 0]	CPU	SATA (pin21, 22)	PCI	Pin17/ 18	SRC	48/96
00	PLL1 ⁽¹⁾	PLL4 SRC ⁽¹⁾	PLL4 (from SRC PLL) ⁽¹⁾	CFB table (default SRC)	PLL4 ⁽¹⁾	PLL2 ⁽³⁾
01	PLL1 ⁽¹⁾	PLL3 ⁽¹⁾	PLL3 ⁽¹⁾	CFB table (default SRC)	PLL4 ⁽¹⁾	PLL2 ⁽³⁾
10	PLL1 ⁽²⁾	PLL3 ⁽¹⁾	PLL3 ⁽¹⁾	CFB table (default SRC)	PLL4 ⁽¹⁾	PLL2 ⁽³⁾
11	PLL1 ⁽²⁾	PLL2 (CV183-1) ⁽³⁾ PLL4 (CV183-2) ⁽¹⁾	PLL4 ⁽¹⁾	Pin17 = 25MHz, PLL2 Pin18 = 1394A, PLL3 ⁽³⁾	PLL4 ⁽¹⁾	PLL2 ⁽³⁾

Note:

1. SSC 0.5% down spread
2. SSC 0.5% denter spread
3. No SSC

CFB TABLE (PIN 17-18)

CFB[3,2,1,0] B1b[4:1]	Pin17, 18	Comments
0000	SRC (PLL4)	SATA/PCI from PLL3 or PLL4 (see CFG table)
0001	SRC (PLL4)	default, SATA/PCI from PLL3 or PLL4 (see CFG table)
0010	100MHz 0.5% SSC (PLL3)	From PLL3 , SATA/PCI from PLL4
0011	100MHz 1.0% SSC (PLL3)	From PLL3 , SATA/PCI from PLL4
0100	100MHz 1.5% SSC (PLL3)	From PLL3 , SATA/PCI from PLL4
0101	100MHz 2.0% SSC (PLL3)	From PLL3 , SATA/PCI from PLL4
110	100MHz 2.5% SSC (PLL3)	From PLL3 , SATA/PCI from PLL4
0111	Reserved	From PLL3 , SATA/PCI from PLL4
1000	1394A 3.3V, SSC off Byte4 bit0 lose control	From PLL3 , SATA/PCI from PLL4
1001	1394A&B 3.3V, SSC off Byte4 bit0 lose control	From PLL3, pin17 = 1394A, pin18 = 1394B, SATA/PCI from PLL4
1010	1394B 3.3V, SSC off Byte4 bit0 lose control	From PLL3 , SATA/PCI from PLL4
1011	27MHz, 3.3V, Byte4 bit0 control the SSC enable, Byte1 bit5 control the down/center	From PLL3 , SATA/PCI from PLL4
1100	25MHz 3.3V, SSC off Byte4 bit0 lose control	From PLL3 , SATA/PCI from PLL4
1101	Pin17 = 25MHz, PLL2 Pin18 = 1394A, PLL3 Both no SSC	25MHz from PLL2 1394 from PLL3, SATA/PCI from PLL4
1110	Reserved	Reserved
1111	Reserved	Reserved

DEVICE ID TABLE

ID3,ID2,ID1,ID0		Comments
0000	CK505 56 pin TSSOP	CK505 YC
0001	CK505 64 pin TSSOP	CK505 YC
0010	48 pin QFN	CK505 YC
0011	56 pin QFN	CK505 YC
0100	64 pin QFN	CK505 YC
0101	72 pin QFN	CK505 YC
0110	48 pin SSOP	CK505 YC
0111	56 pin SSOP	CK505 YC
1000	Reserved	CK505 Derivative (non YC)
1001	Reserved	
1010	Reserved	
1011	Reserved	
1100	Reserved	
1101	Reserved	
1110	Reserved	
1111	Reserved	

IO_VOUT [2:0] TABLE

000	0.3V
001	0.4V
010	0.5V
011	0.6V
100	0.7V
101	0.8V
110	0.9V
111	1V

N-PROGRAMMING PROCEDURE

- Byte 16 bit 3 has to be "1". This bit will decode the power on latched value of pins 4, 5 (see CFG table 1).
- User writes the desired CPU frequency in HEX form into CPUN [8:0], Byte 16, 17.
- User writes the desired SRC frequency in HEX form into PN [7:0], Byte 18.

CONTROL REGISTERS

BYTE 0

Bit	Output(s) Affected	Description/Function	0	1	Type	Power On
7	FSC	Latched FSC			R	Latched Value
6	FSB	Latched FSB			R	Latched Value
5	FSA	Latched FSA			R	Latched Value
4	iAMT_EN	iAMT Mode	Legacy Mode	Enabled	RW	HW M1 setting(1)
3	Reserved				RW	0
2	CFB table enable		Enable CFB table	Disable CFB table (pin 17, 18 is SRC)	RW	0
1	SATA source		Normal, depend on CFB and CGF table	PLL2	RW	0
0	PD_Restore	SMBUS control registers setting after the power down	Power on default, With some exceptions	Save register contents	RW	1

NOTES:

1. Sticky 1, can only be reset by power off.

BYTE 1

Bit	Output(s) Affected	Description/Function	0	1	Type	Power On
7	SRC0_sel	Pin13/14 mode select	SRC0	DOT96	RW	0
6	PLL1_SSC_DC	SSC mode selection	Down spread	Center spread	RW	0
5	PLL3_SSC_DC	SSC mode selection	Down spread	Center spread	RW	0
4	PLL3_CFB3				RW	0
3	PLL3_CFB2	Only valid if Byte0 bit2 = 0			RW	0
2	PLL3_CFB1	See PLL3_CFB table,			RW	0
1	PLL3_CFB0	configure pin17, 18 output mode			RW	1
0	PCI	Reflect PCI PLL status	PLL3	PLL4	R	

BYTE 2

Bit	Output(s) Affected	Description/Function	0	1	Type	Power On
7	REF	Output Enable	Tristate	Enable	RW	1
6	USB_48	Output Enable	Tristate	Enable	RW	1
5	PCIF5	Output Enable	Tristate	Enable	RW	1
4	PCI4	Output Enable	Tristate	Enable	RW	1
3	PCI3	Output Enable	Tristate	Enable	RW	1
2	PCI2	Output Enable	Tristate	Enable	RW	1
1	PCI1	Output Enable	Tristate	Enable	RW	1
0	PCI0	Output Enable	Tristate	Enable	RW	1

BYTE 3

Bit	Output(s) Affected	Description/Function	0	1	Type	Power On
7	SRC11	Output Enable	Tristate	Enabled	RW	1
6	SRC10	Output Enable	Tristate	Enabled	RW	1
5	SRC9	Output Enable	Tristate	Enabled	RW	1
4	SRC8/ITP	Output Enable	Tristate	Enabled	RW	1
3	SRC7	Output Enable	Tristate	Enabled	RW	1
2	SRC6	Output Enable	Tristate	Enabled	RW	1
1	SRC5	Output Enable	Tristate	Enabled	RW	1
0	SRC4	Output Enable	Tristate	Enabled	RW	1

BYTE 4

Bit	Output(s) Affected	Description/Function	0	1	Type	Power On
7	SRC3	Output Enable	Disabled	Enabled	RW	1
6	SATA/SRC2	Output Enable	Disabled	Enabled	RW	1
5	SRC1	Output Enable	Disabled	Enabled	RW	1
4	SRC0/DOT96	Output Enable	Disabled	Enabled	RW	1
3	CPU1	Output Enable	Disabled	Enabled	RW	1
2	CPU0	Output Enable	Disabled	Enabled	RW	1
1	PLL1_SSC_ON	SSC Enable	Disabled	Enabled	RW	1
0	PLL3_SSC_ON	SSC Enable	Disabled	Enabled	RW	1

BYTE 5

Bit	Output(s) Affected	Description/Function	0	1	Type	Power On
7	CR#_A	Pin1 mode selection	PCI0 mode	CR#_A mode	RW	0
6	CR#_A control	CR#_A control selection	SRC0	SRC2	RW	0
5	CR#_B	Pin3 mode selection	PCI1 mode	CR#_B mode	RW	0
4	CR#_B control	CR#_B control selection	SRC1 ⁽¹⁾	SRC4	RW	0
3	CR#_C	Pin24 mode selection	SRCT3 mode	CR#_C mode	RW	0
2	CR#_C control	CR#_C control selection	SRC0	SRC2	RW	0
1	CR#_D	Pin25 mode selection	SRCC3 mode	CR#_D mode	RW	0
0	CR#_D control	CR#_D control selection	SRC1	SRC4	RW	0

NOTE:

1. Only when SRC1 is SRC Clock.

BYTE 6⁽¹⁾

Bit	Output(s) Affected	Description/Function	0	1	Type	Power On
7	CR#_E	Pin43 mode selection, control SRC6	SRCC7 mode	CR#_E mode, Control SRC 6	RW	0
6	CR#_F	Pin44 mode selection, control SRC8	SRCT7 mode	CR#_F mode, Control SRC 8	RW	0
5	CR#_G	Pin32 mode selection, control SRC9	SRCC11 mode	CR#_G mode, Control SRC 9	RW	0
4	CR#_H	Pin33 mode selection, control SRC10	SRCT11 mode	CR#_H mode, Control SRC 10	RW	0
3	Reserved				RW	0
2	Reserved				RW	0
1	SSCD_STP_CRTL	If set, SSCD stop with PCI_STOP#	Free running	Stoppable	RW	0
0	SRC_STP_CRTL	If set, SRCs stop with PCI_STOP#	Free running	Stoppable	RW	0

NOTE:

1. STOP - CPUT and SRCT stay high, CPUC and SRCC stay low.

BYTE 7

Bit	Output(s) Affected	Description / Function	0	1	Type	Power On
7		Revision ID				1
6		Revision ID				0
5		Revision ID				0
4		Revision ID				1
3		Vendor ID				0
2		Vendor ID				1
1		Vendor ID				0
0		Vendor ID				1

BYTE 8

Bit	Output(s) Affected	Description / Function	0	1	Type	Power On
7	Device_ID3	See device ID table			R	
6	Device_ID2				R	
5	Device_ID1				R	
4	Device_ID0				R	
3					RW	0
2					RW	0
1	SE1_OE	Output Enable	Disabled	Enabled	RW	1
0	SE2_OE	Output Enable	Disabled	Enabled	RW	1

BYTE 9

Bit	Output(s) Affected	Description / Function	0	1	Type	Power On
7	PCIF5 with PCI_STOP#	Free running	Free running	stoppable	RW	0
6	TME_STRAP	TME pin 4 power on latch read back	normal	No overclocking	R	
5	REF Drive Strength	Strength control	1x	2x	RW	1
4		Only valid when Byte9 bit3 is 1	Hi-Z	REF/N mode	RW	0
3		Test Mode entry control	Normal operation	Test mode, controlled by byte9 bit 4	RW	0
2	IO_VOUT2				RW	1
1	IO_VOUT1	Programmable IO_Vout voltage			RW	0
0	IO_VOUT0				RW	1

BYTE 10

Bit	Output(s) affected	Description/ Function	0	1	Type	Power On
7		SRC5_EN_Strap			R	The latch of SRC5_EN
6	PLL3	PLL3 enable	PLL3 pwr dwn	Pwr up	RW	1
5	PLL2	PLL2 enable	PLL2 pwr dwn	Pwr up	RW	1
4	SRC_DIV	SRC divider disable	disable	enable	RW	1
3	PCI_DIV	PCI divider disable	disable	enable	RW	1
2	CPU_DIV	CPU divider disable	disable	enable	RW	1
1	CPU1 Free run	Controlled by CPU_STP#	Free run	Controllable	RW	1
0	CPU0 Free run	Controlled by CPU_STP#	Free run	Controllable	RW	1

BYTE 11

Bit	Output(s) affected	Description/ Function	0	1	Type	Power On
7	CFG1				R	See CFG table 1, 2
6	CFG0				R	See CFG table 1, 2
5	25MHz-EN	25MHz disabled in PD/ M1 (for both PLL3 and PLL2 25MHZ)	disabled	Enabled (Can not be reset by PD restore at power down)	RW	0
4	Reserved				RW	1
3	CPU_ITP_AMT_EN	M1 mode CLK enable at M1 mode Only if ITP_EN = 1	disable	enable	RW	0
2	CPU1_AMT_EN	M1 mode CLK enable at M1 mode	disable	enable	RW	1
1	PCI GEN II	GEN II compliance	None GEN II	GEN II	R	1
0	CPU_ITP_STOP EN	Free run control	Free run	Controlled	RW	1

BYTE 12 - BYTE COUNT - DEFAULT 0x13H

BYTE 13

Bit	Output(s) Affected	Description / Function	0	1	Type	Power On
7	48M	Strength control	1	1.2	RW	1
6	REF	Strength control	1	1.2	RW	1
5	PCIF5	Strength control	1	1.2	RW	0
4	PCI4	Strength control	1	1.2	RW	0
3	PCI3	Strength control	1	1.2	RW	0
2	PCI2	Strength control	1	1.2	RW	0
1	PCI1	Strength control	1	1.2	RW	0
0	PCI0	Strength control	1	1.2	RW	0

BYTE 14 RESERVED

BYTE 15, WATCH DOG⁽¹⁾

Bit	Output(s) Affected	Description / Function	0	1	Type	Power On
7	Watch Dog Enable	Watch Dog Alarm Enable	Disabled	Enabled	RW	0
6	Watch Dog Select	Watch Dog Hard/Soft Alarm Select	Hard Alarm Only	Hard and Soft Alarm	RW	0
5	Watch Dog Hard Alarm Status	Watch Dog Hard Alarm Status	Normal	Alarm	R	
4	Watch Dog Soft Alarm Status	Watch Dog Soft Alarm Status	Normal	Alarm	R	
3	Watch Dog control	Watch Dog Time Base Control	290ms base	1160ms base	RW	0
2	WD_1_Timer 2	WatchDog_1_Alarm Timer Default is 7*290ms			RW	1
1	WD_1_Timer 1				RW	1
0	WD_1_Timer 0				RW	1

NOTE:

1. Hard Alarm switch to HW FS frequency.

BYTE 16

Bit	Output(s) Affected	Description / Function	0	1	Type	Power On
7	WDEAPD	Set Byte15 bit7 = 1 after Power Down to enable the watch dog after the power down	Disabled	Enabled	RW	0
6	27MHz SSC1	See 27MHz SSC Table			RW	0
5	27MHz SSC0	See 27MHz SSC Table			RW	0
4	Test_scl	On chip test mode enable	normal	SCLK=1, clk outputs = 1 SCLK=0, clk outputs=0	RW	0
3	N programming	See CFG table 1	Disabled	Enabled	RW	Power on latch
2	Reserved				RW	0
1	Reserved				RW	0
0	CPUN8				RW	FS latch

27MHZ SSC TABLE

27MHz SSC1, SSC0	Spread (Byte1 bit5 control center or down spread)
00	0.5%
01	1.0%
10	1.5%
11	2.0%

BYTE 17 (PLL1)

Bit	Output(s) Affected	Description / Function	0	1	Type	Power On
7	CPUN7	CPU clock frequency = CPUN [8:0] (Hex)			RW	FS latch
6	CPUN6				RW	
5	CPUN5				RW	
4	CPUN4				RW	
3	CPUN3				RW	
2	CPUN2				RW	
1	CPUN1				RW	
0	CPUN0				RW	

BYTE 18 (PLL3)

Bit	Output(s) Affected	Description / Function	0	1	Type	Power On
7	PN 7	SRC clock frequency = PNC [7:0] (Hex)			RW	100MHz
6	PN 6				RW	
5	PN 5				RW	
4	PN 4				RW	
3	PN 3				RW	
2	PN 2				RW	
1	PN 1				RW	
0	PN 0				RW	

BYTE 19 CLOCK SOURCE SELECTION, WRITTEN AFTER STOP BIT

Bit	Output(s) Affected	Description / Function	0	1	Type	Power On
7	Output serial resistor		0 ohm (External resistor needed)	33 ohm (No external resistor needed)	RW	0
6	PLL1 SSC	spread % selection	0.5% (p-p)	0.45%(p-p)	RW	0
5	PLL3 SSC			0.45%(p-p)	RW	0
4	PLL4 SSC			0.45%(p-p)	RW	0
3	PLL4_SSC_DC	SSC mode selection	Down spread centered at 99.75MHz	center spread	RW	0
2	Reserved				RW	0
1	Reserved				RW	0
0	Reserved				RW	0

BYTE 30

Bit	Output(s) affected	Description/ Function	0	1	Type	Power On
7		Don't change the default			RW	1
6		Don't change the default			RW	0
5		Don't change the default			RW	0
4		Don't change the default			RW	0
3		Don't change the default			RW	0
2		Don't change the default			RW	0
1	PLL4 (SRC)	SSC on/off control	disable	enable	RW	1
0		Don't change the default			RW	0

ABSOLUTE MAXIMUM RATINGS

PARAMETER	SYMBOL	CONDITIONS	MIN	MAX	UNITS	Notes
Maximum Supply Voltage	VDDxxx	Supply Voltage		4.6	V	1,7
Maximum Supply Voltage	VDDxxx_IO	Low-Voltage Differential I/O Supply		3.8	V	1,7
Maximum Input Voltage	V _{IH}	3.3V LVCMOS Inputs		4.6	V	1,7,8
Minimum Input Voltage	V _{IL}	Any Input	GND - 0.5		V	1,7
Storage Temperature	T _s	-	-65	150	°C	1,7
Input ESD protection	ESD prot	Human Body Model	2000		V	1,7

ELECTRICAL CHARACTERISTICS - INPUT/SUPPLY/COMMON OUTPUT PARAMETERS

PARAMETER	SYMBOL	CONDITIONS	MIN	MAX	UNITS	Notes
Ambient Operating Temp	T _{ambient}	-	0	70	°C	1
Supply Voltage	VDDxxx	Supply Voltage	3.135	3.465	V	1
Supply Voltage	VDDxxx_IO	Low-Voltage Differential I/O Supply	0.70	0.88	V	1
Input High Voltage	V _{IHSE}	Single-ended inputs	2	V _{DD} + 0.3	V	1
Input Low Voltage	V _{ILSE}	Single-ended inputs	V _{SS} - 0.3	0.8	V	1
Input Leakage Current	I _{IN}	V _{IN} = V _{DD} , V _{IN} = GND	-5	5	uA	1
Input Leakage Current	I _{INRES}	Inputs with pull or pull down resistors V _{IN} = V _{DD} , V _{IN} = GND	-200	200	uA	1
Output High Voltage	V _{OHSE}	Single-ended outputs, I _{OH} = -1 mA	2.4		V	1
Output Low Voltage	V _{OLSE}	Single-ended outputs, I _{OL} = 1 mA		0.4	V	1
Output High Voltage	V _{OHDF}	Differential Outputs, I _{OH} = TBD mA	0.7	0.9	V	1
Output Low Voltage	V _{OLDIF}	Differential Outputs, I _{OL} = TBD mA		0.4	V	1
Low Threshold Input-High Voltage (Test Mode)	V _{IH_FS_TEST}	3.3 V +/-5%	2	V _{DD} + 0.3	V	1
Low Threshold Input-High Voltage	V _{IH_FS}	3.3 V +/-5%	0.7	1.5	V	1
Low Threshold Input-Low Voltage	V _{IL_FS}	3.3 V +/-5%	V _{SS} - 0.3	0.35	V	1
Operating Supply Current	I _{DD_DP}	3.3V supply, PLL3 off		140	mA	1
	I _{DD_IO}	0.8V supply, Differential IO current, all outputs enabled		30	mA	1
Power Down Current	I _{DD_PD3.3}	3.3V supply, Power Down Mode		5	mA	1
	I _{DD_PDIO}	0.8V IO supply, Power Down Mode		0	mA	1
iAMT Mode Current	I _{DD_iAMT3.3}	3.3V supply, iAMT Mode		30	mA	1
	I _{DD_iAMT0.8}	0.8V IO supply, iAMT Mode		10	mA	1
Input Frequency	F _i	V _{DD} = 3.3 V		14.31818	MHz	2
Pin Inductance	L _{pin}			7	nH	1
Input Capacitance	C _{IN}	Logic Inputs	1.5	5	pF	1
	C _{OUT}	Output pin capacitance		6	pF	1
	C _{INX}	X1 & X2 pins		TBD	pF	1
Spread Spectrum Modulation Frequency	f _{SSMOD}	Triangular Modulation	30	33	kHz	1

AC ELECTRICAL CHARACTERISTICS - INPUT/COMMON PARAMETERS

PARAMETER	SYMBOL	CONDITIONS	MIN	MAX	UNITS	Notes
Clk Stabilization	T_{STAB}	From VDD Power-Up or de-assertion of PD# to 1st clock		1.8	ms	1
Tdrive_SRC	T_{DRSRC}	SRC output enable after PCI_STOP# de-assertion		15	ns	1
Tdrive_PD#	T_{DRPD}	Differential output enable after PD# de-assertion		300	us	1
Tdrive_CPU	T_{DRSRC}	CPU output enable after CPU_STOP# de-assertion		10	ns	1
Tfall_PD#	T_{FALL}	Fall/rise time of PD#, PCI_STOP# and CPU_STOP# inputs		5	ns	1
Trise_PD#	T_{RISE}			5	ns	1

AC ELECTRICAL CHARACTERISTICS - LOW POWER DIFFERENTIAL OUTPUTS

PARAMETER	SYMBOL	CONDITIONS	MIN	MAX	UNITS	NOTES
Rising Edge Slew Rate	t_{SLR}	Differential Measurement	2.5	5	V/ns	1,2
Falling Edge Slew Rate	t_{FLR}	Differential Measurement	2.5	5	V/ns	1,2
Slew Rate Variation	t_{SLVAR}	Single-ended Measurement		20	%	1
Maximum Output Voltage	V_{HIGH}	Includes overshoot		1150	mV	1
Minimum Output Voltage	V_{LOW}	Includes undershoot	-300		mV	1
Differential Voltage Swing	V_{SWING}	Differential Measurement	300		mV	1
Crossing Point Voltage	V_{XABS}	Single-ended Measurement	300	550	mV	1,3,4
Crossing Point Variation	$V_{XABSVAR}$	Single-ended Measurement		140	mV	1,3,5
Duty Cycle	D_{CYC}	Differential Measurement	45	55	%	1
CPU Jitter - Cycle to Cycle	$CPUJ_{C2C}$	Differential Measurement		85	ps	1
SRC Jitter - Cycle to Cycle	$SRCJ_{C2C}$	Differential Measurement		125	ps	1
DOT Jitter - Cycle to Cycle	$DOTJ_{C2C}$	Differential Measurement		250	ps	1
CPU[1:0] Skew	CPU_{SKEW10}	Differential Measurement		100	ps	1
CPU[2_ITP:0] Skew	CPU_{SKEW20}	Differential Measurement		150	ps	1
SRC[10:0] Skew	SRC_{SKEW}	Differential Measurement		250	ps	1,10

ELECTRICAL CHARACTERISTICS - PCICLK/PCICLK_F

PARAMETER	SYMBOL	CONDITIONS	MIN	MAX	UNITS	NOTES
Long Accuracy	ppm	see Tperiod min-max values	-300	300	ppm	1,6
Clock period	T_{period}	33.33MHz output nominal	29.99100	30.00900	ns	6
		33.33MHz output spread		30.15980	ns	6
Absolute min/max period	T_{abs}	33.33MHz output nominal/spread	29.49100	30.65980	ns	6
Output High Voltage	V_{OH}	$I_{OH} = -1$ mA	2.4		V	1
Output Low Voltage	V_{OL}	$I_{OL} = 1$ mA		0.4	V	1
Output High Current	I_{OH}	$V_{OH} @ MIN = 1.0$ V	-33		mA	1
		$V_{OH} @ MAX = 3.135$ V		-33	mA	1
Output Low Current	I_{OL}	$V_{OL} @ MIN = 1.95$ V	30		mA	1
		$V_{OL} @ MAX = 0.4$ V		38	mA	1
Rising Edge Slew Rate	t_{SLR}	Measured from 0.8 to 2.0 V	1	4	V/ns	1
Falling Edge Slew Rate	t_{FLR}	Measured from 2.0 to 0.8 V	1	4	V/ns	1
Duty Cycle	d_{t1}	$V_T = 1.5$ V	45	55	%	1
Skew	t_{skew}	$V_T = 1.5$ V		250	ps	1
Intentional PCI-PCI delay	t_{delay}	$V_T = 1.5$ V	200 nominal		ps	1,9
Jitter, Cycle to cycle	$t_{jcc-cyc}$	$V_T = 1.5$ V		500	ps	1

ELECTRICAL CHARACTERISTICS - USB48MHZ

PARAMETER	SYMBOL	CONDITIONS	MIN	MAX	UNITS	NOTES
Long Accuracy	ppm	see T _{period} min-max values	-100	100	ppm	1,2
Clock period	T _{period}	48.00MHz output nominal	20.83125	20.83542	ns	2
Absolute min/max period	T _{abs}	48.00MHz output nominal	20.48130	21.18540	ns	2
Output High Voltage	V _{OH}	I _{OH} = -1 mA	2.4		V	1
Output Low Voltage	V _{OL}	I _{OL} = 1 mA		0.4	V	1
Output High Current	I _{OH}	V _{OH} @ MIN = 1.0 V	-29		mA	1
		V _{OH} @ MAX = 3.135 V		-23	mA	1
Output Low Current	I _{OL}	V _{OL} @ MIN = 1.95 V	29		mA	1
		V _{OL} @ MAX = 0.4 V		27	mA	1
Rising Edge Slew Rate	t _{SLR}	Measured from 0.8 to 2.0 V	1	2	V/ns	1
Falling Edge Slew Rate	t _{FLR}	Measured from 2.0 to 0.8 V	1	2	V/ns	1
Duty Cycle	d _{t1}	V _T = 1.5 V	45	55	%	1
Jitter, Cycle to cycle	t _{jyc-cyc}	V _T = 1.5 V		350	ps	1

ELECTRICAL CHARACTERISTICS - SMBUS INTERFACE

PARAMETER	SYMBOL	CONDITIONS	MIN	MAX	UNITS	Notes
SMBus Voltage	V _{DD}		2.7	5.5	V	1
Low-level Output Voltage	V _{OLSMB}	@ I _{PULLUP}		0.4	V	1
Current sinking at V _{OLSMB} = 0.4 V	I _{PULLUP}	SMB Data Pin	4		mA	1
SCLK/SDATA Clock/Data Rise Time	T _{RI2C}	(Max VIL - 0.15) to (Min VIH + 0.15)		1000	ns	1
SCLK/SDATA Clock/Data Fall Time	T _{FI2C}	(Min VIH + 0.15) to (Max VIL - 0.15)		300	ns	1
Maximum SMBus Operating Frequency	F _{SMBUS}	Block Mode		100	kHz	1

ELECTRICAL CHARACTERISTICS - REF-14.318MHZ

PARAMETER	SYMBOL	CONDITIONS	MIN	MAX	UNITS	Notes
Long Accuracy	ppm	see T _{period} min-max values	-300	300	ppm	1,2
Clock period	T _{period}	14.318MHz output nominal	69.8203	69.8622	ns	2
Absolute min/max period	T _{abs}	14.318MHz output nominal	69.8203	70.86224	ns	2
Output High Voltage	V _{OH}	I _{OH} = -1 mA	2.4		V	1
Output Low Voltage	V _{OL}	I _{OL} = 1 mA		0.4	V	1
Output High Current	I _{OH}	V _{OH} @ MIN = 1.0 V, V _{OH} @ MAX = 3.135 V	-33	-33	mA	1
Output Low Current	I _{OL}	V _{OL} @ MIN = 1.95 V, V _{OL} @ MAX = 0.4 V	30	38	mA	1
Rising Edge Slew Rate	t _{SLR}	Measured from 0.8 to 2.0 V	1	4	V/ns	1
Falling Edge Slew Rate	t _{FLR}	Measured from 2.0 to 0.8 V	1	4	V/ns	1
Duty Cycle	d _{t1}	V _T = 1.5 V	45	55	%	1
Jitter	t _{jyc-cyc}	V _T = 1.5 V		1000	ps	1

Notes on Electrical Characteristics:

¹Guaranteed by design and characterization, not 100% tested in production.

²Slew rate measured through V_{swing} centered around differential zero

³V_{xabs} is defined as the voltage where CLK = CLK#

⁴Only applies to the differential rising edge (CLK rising and CLK# falling)

⁵Defined as the total variation of all crossing voltages of CLK rising and CLK# falling. Matching applies to rising edge rate of CLK and falling edge of CLK#. It is measured using a +/-75mV window centered on the average cross point where CLK meets CLK#.

⁶All Long Term Accuracy and Clock Period specifications are guaranteed assuming that REFOUT is at 14.31818MHz

⁷Operation under these conditions is neither implied, nor guaranteed.

⁸Maximum input voltage is not to exceed maximum VDD

⁹See PCI Clock-to-Clock Delay Figure

¹⁰SRC 3,4,6,7, are 0 ps nominal interpair skew

PCI STOP FUNCTIONALITY

PCI_STOP#	SRC	SRC#	PCI
1	Normal	Normal	33MHz
0	High	Low	Low

PCI_STOP# ASSERTION (TRANSITION FROM '1' TO '0')

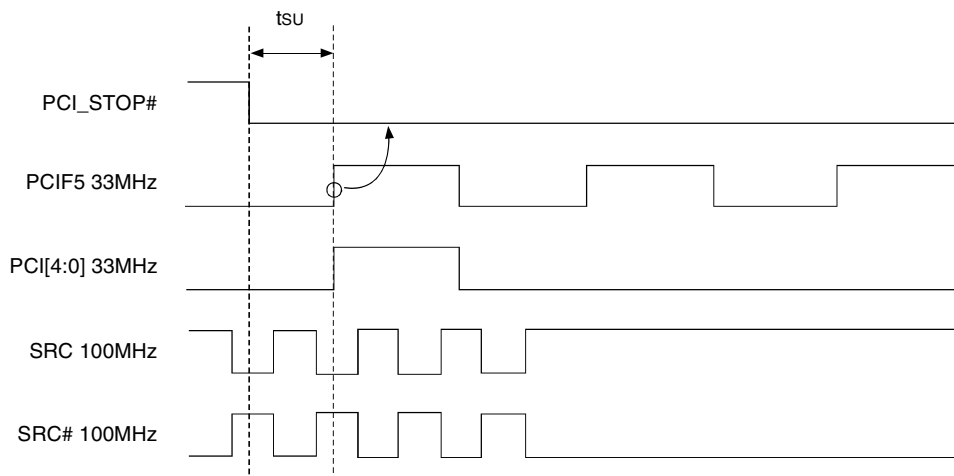

PCI_STOP# - DE-ASSERTION (TRANSITION FROM '0' TO '1')

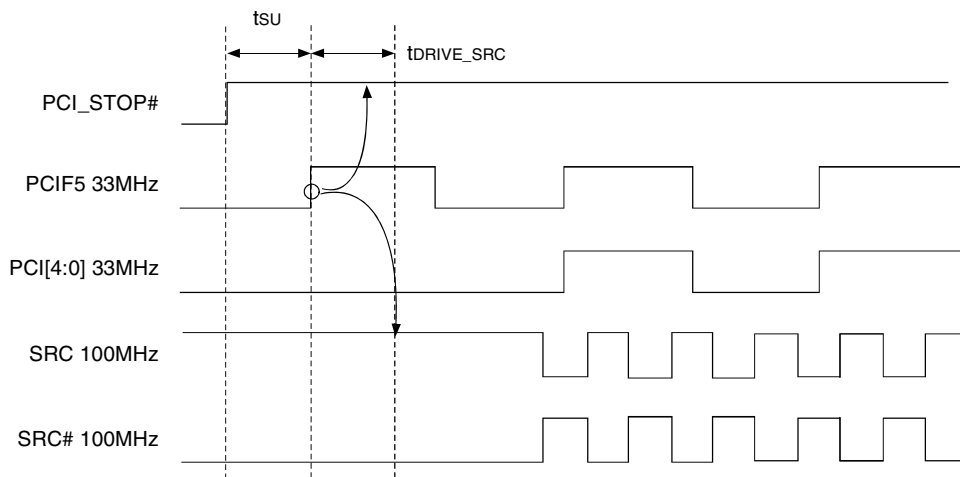

CPU STOP FUNCTIONALITY

The CPU_STOP# signal is an active low input controlling the CPU outputs. This signal can be asserted asynchronously.

CPU_STOP#	CPU	CPU#
1	Normal	Normal
0	High	Low

CPU_STOP# ASSERTION (TRANSITION FROM '1' TO '0')

Asserting CPU_STOP# pin stops all CPU outputs that are set to be stoppable after their next transition. When the SMBus CPU_STOP tri-state bit corresponding to the CPU output of interest is programmed to a '0', CPU output will stop CPU_True = High and CPU_Complement = Low. When the SMBus CPU_STOP# tri-state bit corresponding to the CPU output of interest is programmed to a '1', CPU outputs will be tri-stated.

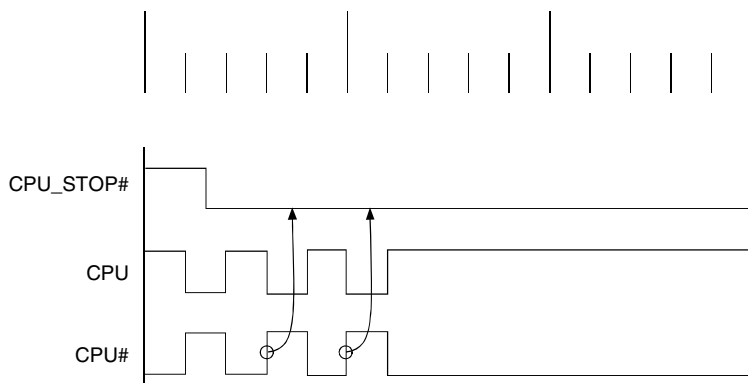

CPU_STOP# - DE-ASSERTION (TRANSITION FROM '0' TO '1')

With the de-assertion of CPU_STOP# all stopped CPU outputs will resume without a glitch. The maximum latency from the de-assertion to active outputs is two to six CPU clock periods. If the control register tristate bit corresponding to the output of interest is programmed to '1', then the stopped CPU outputs will be driven High within 10nS of CPU_STOP# de-assertion to a voltage greater than 200mV.

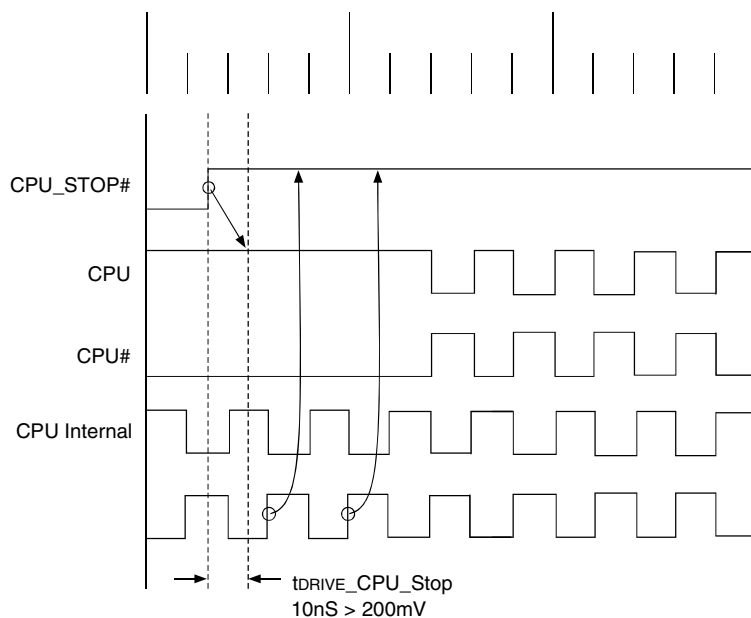

PD# ASSERTION

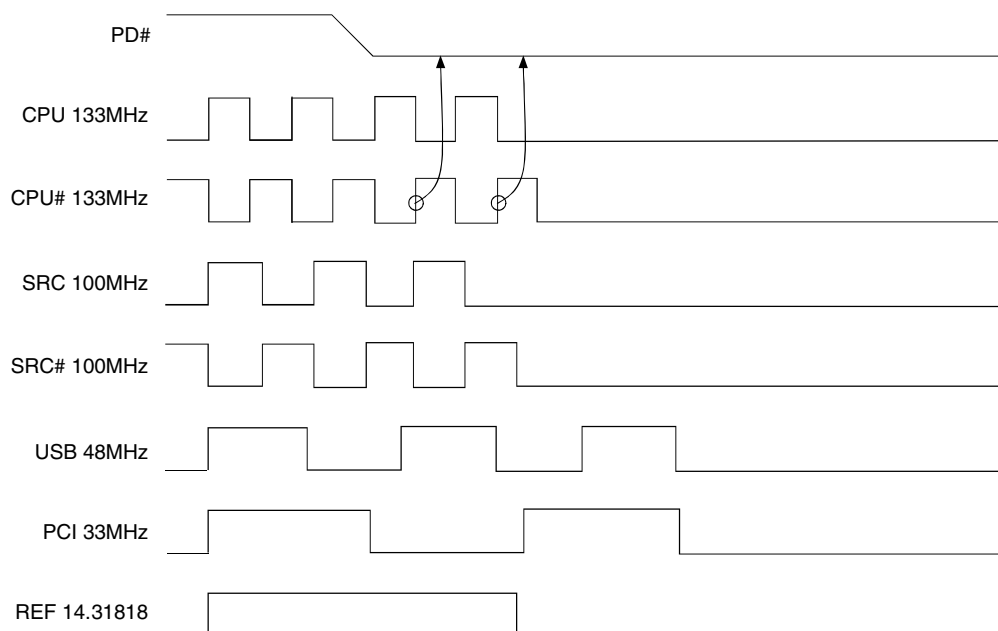

PD# DE-ASSERTION

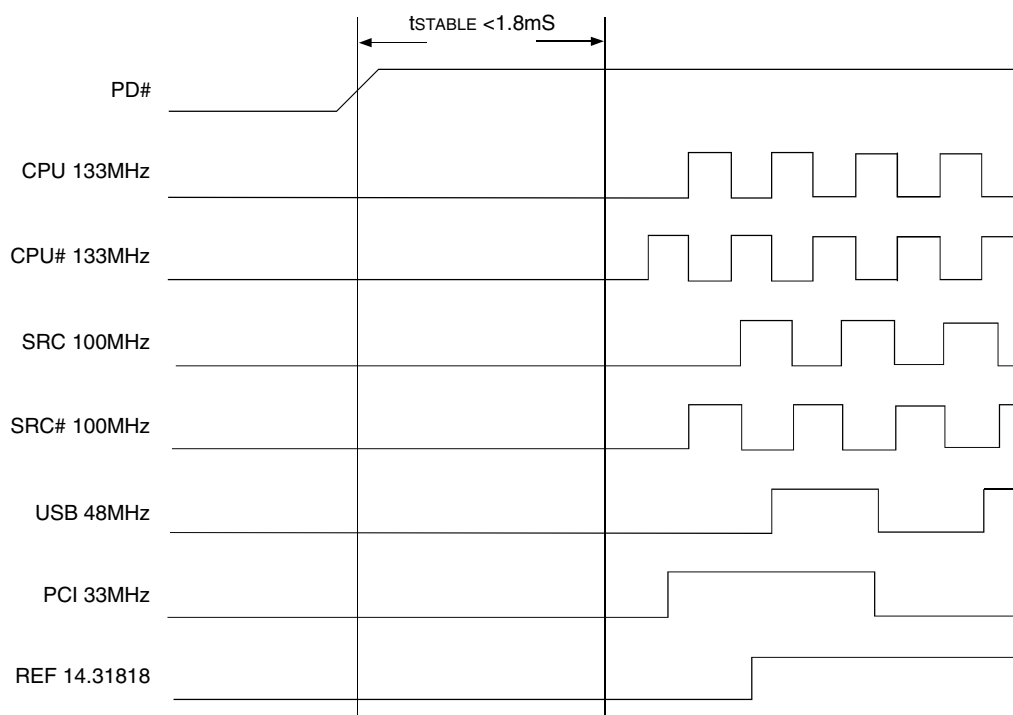

TSSOP PACKAGE DIMENSIONS

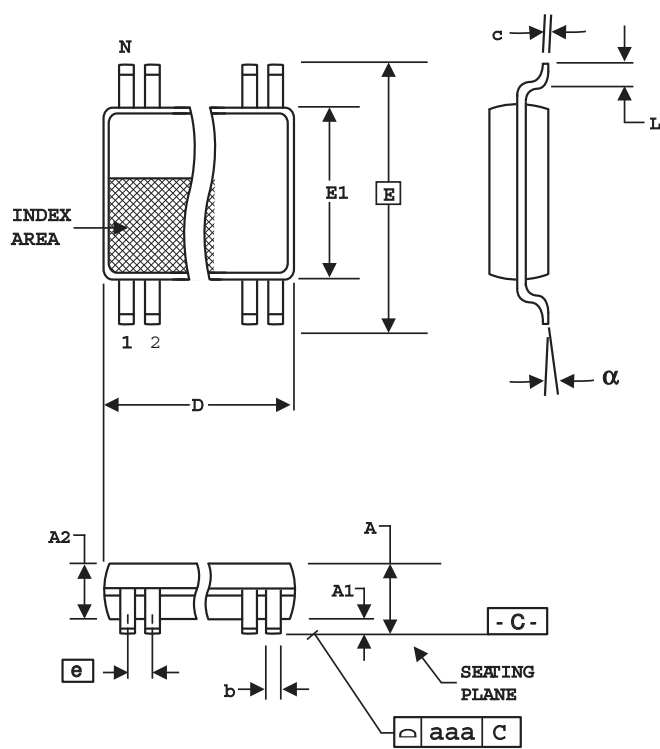

6.10 mm. Body, 0.50 mm. Pitch TSSOP
(240 mil) (20 mil)

SYMBOL	In Millimeters		In Inches	
	COMMON DIMENSIONS		COMMON DIMENSIONS	
	MIN	MAX	MIN	MAX
A	--	1.20	--	.047
A1	0.05	0.15	.002	.006
A2	0.80	1.05	.032	.041
b	0.17	0.27	.007	.011
c	0.09	0.20	.0035	.008
D	SEE VARIATIONS		SEE VARIATIONS	
E	8.10 BASIC		0.319 BASIC	
E1	6.00	6.20	.236	.244
e	0.50 BASIC		0.020 BASIC	
L	0.45	0.75	.018	.030
N	SEE VARIATIONS		SEE VARIATIONS	
α	0°	8°	0°	8°
aaa	--	0.10	--	.004

VARIATIONS

N	D mm.		D (inch)	
	MIN	MAX	MIN	MAX
64	16.90	17.10	.665	.673

Reference Doc.: JEDEC Publication 95, MO-153

10-0039

Ordering Information

Part / Order Number	Shipping Packaging	Package	Temperature
CV183-2BPAG	Tubes	64-pin TSSOP	0 to +70° C
CV183-2BPAG8	Tape and Reel	64-pin TSSOP	0 to +70° C

"G" after the two-letter package code are the Pb-Free configuration, RoHS compliant.
"B" is the device revision designator (will not correlate with the datasheet revision).



CORPORATE HEADQUARTERS
6024 Silver Creek Valley Road
San Jose, CA 95138

for SALES:
800-345-7015 or 408-284-8200
fax: 408-284-2775
www.idt.com

for Tech Support:
pcclockhelp@idt.com

REVISION HISTORY

May 11, 2011 RDW Created/updated -2B datasheet.