

Verpackt in Gurtverpackung
Tape on Reel Packaging
Verpackungseinheit: 400 Stück
Packaging unit: 400 pcs

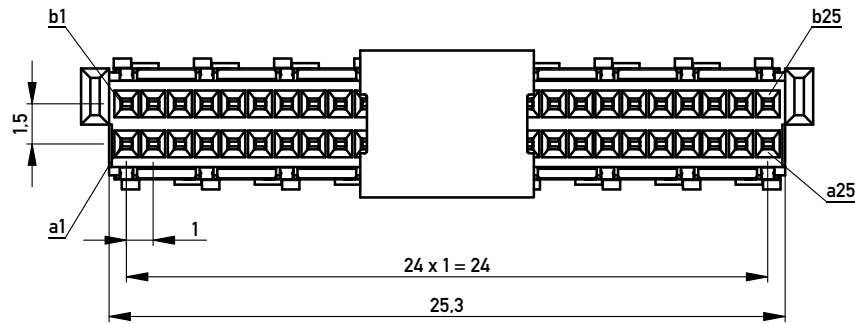

Abspulrichtung - Reel off Direction →

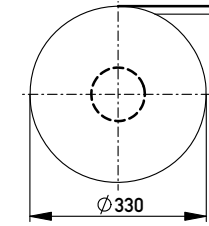
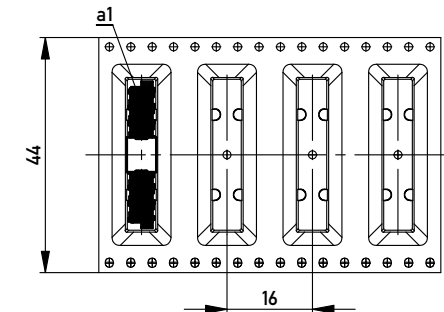

Leiterplatten-Layout Vorschlag / PCB-Layout Proposal

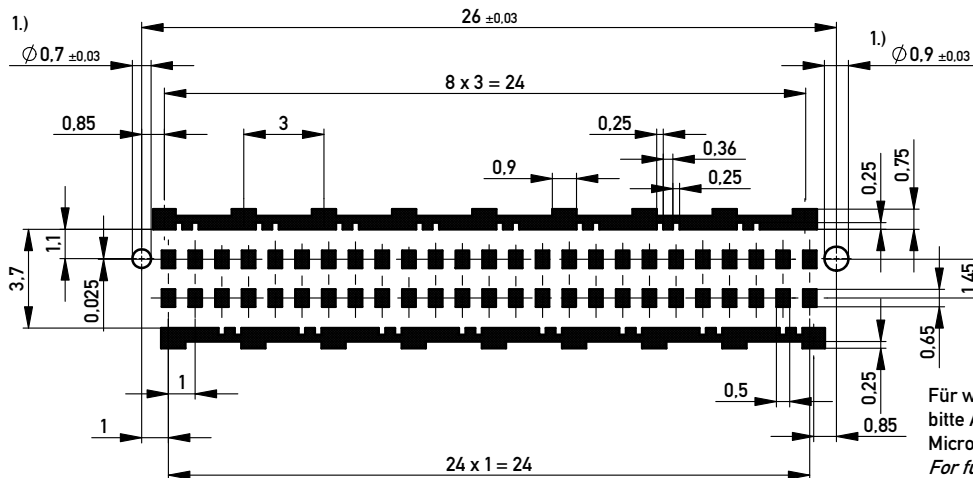

1.) Durchmesser des Bohrers / Drill tool

Für weitere Layout Details
bitte Applikations Schrift
MicroSpeed beachten.
For further layout details
please consider
MicroSpeed application note.

Anforderungsstufe 1
Performance Level 1

Kontaktbereich vergoldet
Mating Area gold plating

Anschlussbereich verzinkt 4-6 µm
Terminal Area 4-6 µm tin plating

Koplanarität der Anschlüsse ≤ 0,1 mm
Coplanarity Area of Termination ≤ 0,1 mm

Information:		Tolerances		Scale	5:1
All rights reserved. Only for Information. To ensure that this is the latest version of this drawing, please contact one of the ERNI companies before using.		All Dimensions in mm		Designation	
Subject to modification without prior notice. Drawing will not be updated.		www.ERNI.com		Federl. 4mm SMD 50-pol. BM EMV Female 4mm SMD 50 cont. BM EMV	
ERNI		www.ERNI.com		374725	
b	07.08.2012			I	
Index	Date			A3	
				Class	MSPEED

Copyright by ERNI GmbH
Proprietary notice pursuant to ISO 16016 to be observed.