

**STRAIGHT BULKHEAD JACK CRIMP TYPE**

**R114.312.000**

**REAR MOUNT - CABLE 2.6/50+75 S**

Series : SMB

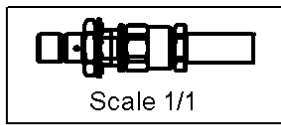
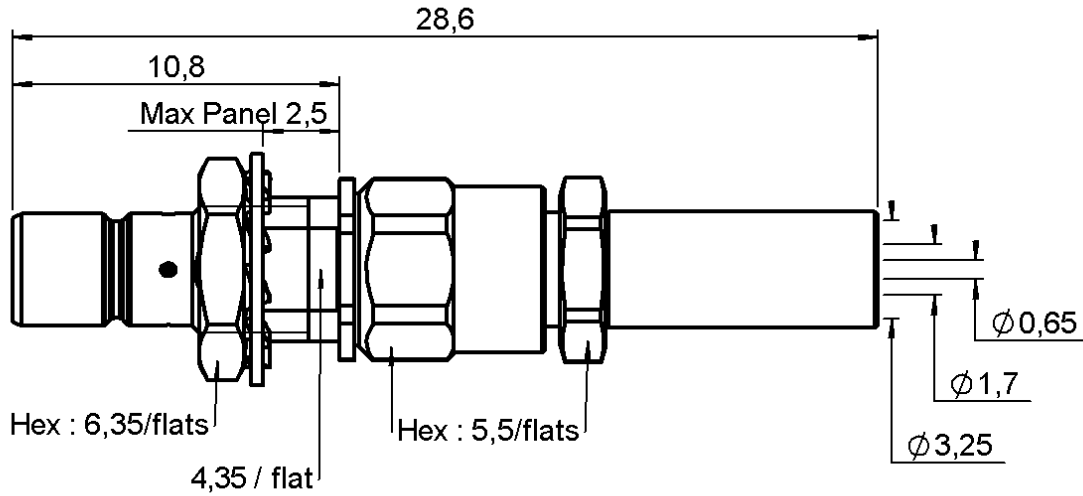

**PANEL CUT OUT**

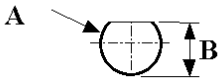

mm		
	Maxi	mini
A	5	4.9
B	4.55	4.45

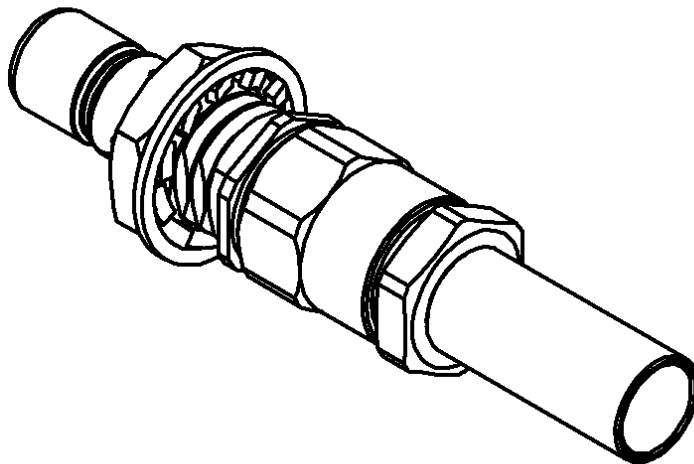

All dimensions are in mm.

COMPONENTS	MATERIALS	PLATINGS (µm)
BODY	BRASS	GOLD 0.2 OVER NICKEL 2
CENTER CONTACT	BRASS	GOLD 1.3 OVER NICKEL 2
OUTER CONTACT	-	-
INSULATOR	PTFE	-
GASKET	-	-
OTHERS PARTS	BRASS	GOLD 0.2 OVER NICKEL 2
-	-	-
-	-	-

Issue : 0217 E

In the effort to improve our products, we reserve the right to make changes judged to be necessary.



**STRAIGHT BULKHEAD JACK CRIMP TYPE**

**R114.312.000**

**REAR MOUNT - CABLE 2.6/50+75 S**

Series : SMB

**PACKAGING**

Standard	Unit	Other
<b>100</b>	<b>'W' option</b>	<b>Contact us</b>

**SPECIFICATION**

**ELECTRICAL CHARACTERISTICS**

Impedance		<b>50</b> Ω
Frequency		<b>0-4</b> GHz
VSWR	<b>1.25</b> +	<b>0.040</b> x F(GHz) Maxi
Insertion loss		<b>0.25</b> √F(GHz) dB Maxi
RF leakage	- (	<b>57</b> - F(GHz)) dB Maxi
Voltage rating		<b>335</b> Veff Maxi
Dielectric withstanding voltage		<b>1000</b> Veff mini
Insulation resistance		<b>1000</b> MΩ mini

**CABLE ASSEMBLY**

Stripping	a	b	c	d	e	f
mm	2.20	5.40	15.5	0.00	13.3	0.00

Assembly instruction : **Crimp 10**

Recommended cable(s)  
 RG 316  
 RG 179  
 RG 187  
 KX 22A  
 RG 188

Cable retention  
 - pull off **110** N mini  
 - torque **NA** N.cm

**MECHANICAL CHARACTERISTICS**

Center contact retention		
Axial force – Mating end	<b>10</b>	N mini
Axial force – Opposite end	<b>10</b>	N mini
Torque	<b>NA</b>	N.cm mini

**TOOLING**

Part Number	Description	Hexagon
.	.	.
R282.235.003	CRIMPING DIES	3.25
R282.211.000	CRIMPING TOOL	3.25
R282.293.000	CRIMPING TOOL	-

Recommended torque		
Mating	<b>NA</b>	N.cm
Panel nut	<b>60</b>	N.cm
Clamp nut	<b>63</b>	N.cm
A/F clamp nut	<b>5.500</b>	mm

Mating life	<b>500</b>	Cycles mini
Weight	<b>3.120</b>	g

**OTHERS CHARACTERISTICS**

-

**ENVIRONMENTAL**

Operating temperature	<b>-65/+165</b>	° C
Hermetic seal	<b>NA</b>	Atm.cm3/s
Panel leakage	<b>NA</b>	

Issue : 0217 E

In the effort to improve our products, we reserve the right to make changes judged to be necessary.

